

STRAUB-OPEN-FLEX 3 | \varnothing 219.1 - 4064.0 mm

Components / Materials	W1	W2	W4	W5
Casing	S355MC, hot-dip galvanised	AISI 316 L or similar		AISI 316 L or similar
Bolts	AISI 4135	AISI 4135		A4 - 80
Bars	AISI 12L14, galvanised	AISI 12L14, galvanised		AISI 316 L or similar
Strip insert (option)	AISI 316 L or similar / HDPE	AISI 316 L or similar / HDPE		AISI 316 L or similar / HDPE
Sealing sleeve EPDM	Temp.: -20°C up to +100°C Medium: all qualities of water, waste water, air, solids and chemical products			
Sealing sleeve NBR	Temp.: -20°C up to +80°C Medium: water, gas, oil, fuel and other hydrocarbons			
Sealing sleeve FPM/FKM (on request)	Temp.: -20°C up to +180°C Medium: ozone, oxygen, acids, gas, oil and fuel (only with strip insert)			

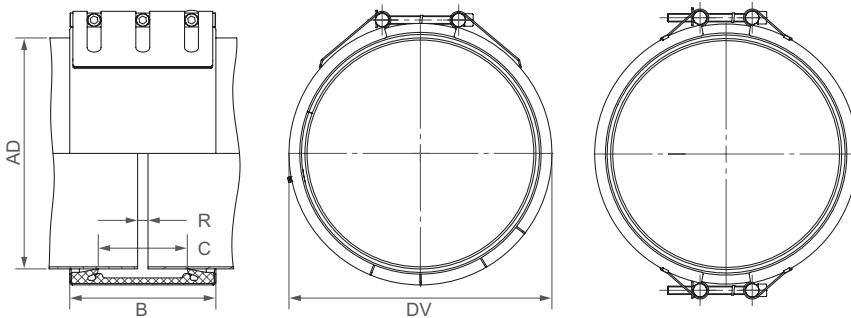

B ⇔ 210 up to 218 mm
 DV ⇔ OD + 38 mm
 C ⇔ 127 mm
 R with strip insert ⇔ 60 mm
 R without strip insert ⇔ 15 mm

	W2 or W5
	W1, W2 or W5
	W1 or W5
	only in W1 available



OD [mm]	Clamping range [mm]	PN					
		2.5	6	10	16	20	25
219.1	216 - 222						
250.0	247 - 253						
267.0	264 - 270						
273.0	270 - 276						
304.0	301 - 307						
323.9	321 - 327						
355.6	352 - 358						
406.4	403 - 409						
457.2	454 - 460						
508.0	504 - 512						
558.8	555 - 562						
609.6	606 - 613						
711.2	707 - 715						
762.0	758 - 766						
812.8	809 - 817						
914.4	910 - 918						
1016.0	1012 - 1020						
1117.6	1113 - 1122						
1219.2	1215 - 1224						
1320.8	1316 - 1325						
1422.4	1418 - 1427						
1524.0	1519 - 1529						
1600.0	1595 - 1605						
1625.6	1621 - 1631						
1727.2	1722 - 1732						
1828.8	1824 - 1834						
1930.4	1925 - 1935						
2032.0	2027 - 2037						
2268.0	2263 - 2273						
2540.0	2535 - 2545						
2794.0	2789 - 2799						
3048.0	3043 - 3053						
3302.0	3296 - 3308						
3556.0	3548 - 3562						
3810.0	3804 - 3816						
4064.0	4058 - 4070						

CONTINUOUSLY VARIABLE INTERMEDIATE SIZES FROM 219.1 TO 4064.0 mm ARE AVAILABLE

Remarks:

- Follow fitting instructions
- PN = working pressure considering the application loads
Test pressure = PN x 1.5 (e.g. industry, water supply etc.)
- Strip inserts are optional accessories (see Technical Manual STRAUB)
- Additional sealing sleeves, pressure and temperature ranges on request

Versions:

PN						1 piece (slotted) [mm]	2 piece casing [mm]	3 piece casing [mm]
2.5	6	10	16	20	25			
x						219.1 - 1219.2 (2 pc casing on order)	1219.2 - 3048.0	> 3048.0
	x					508.0 - 914.4 (2 pc casing on order)	219.1 - 508.0	> 3048.0
		x				508.0 (2 pc casing on order)	914.4 - 3048.0	> 3048.0
			x	x	x		219.1 - 3048.0	
							219.1 - 2540.0	

⇨ pressure rating definition, see above