

STRAUB-OPEN-FLEX 1 | \varnothing 48.3 - 168.3 mm

Components / Materials	W1	W2	W4	W5
Casing		AISI 316 L or similar		AISI 316 L or similar
Bolts		AISI 4135		A4 - 80
Bars		AISI 12L14, galvanised		AISI 316 L
Strip insert (option)		AISI 316 L or similar / VDF		AISI 316 L or similar / PVDF
Sealing sleeve EPDM	Temp.: -20°C up to +100°C Medium: all qualities of water, waste water, air, solids and chemical products			
Sealing sleeve NBR	Temp.: -20°C up to +80°C Medium: water, gas, oil, fuel and other hydrocarbons			
Sealing sleeve FPM/FKM	Temp.: -20°C up to +180°C Medium: ozone, oxygen, acids, gas, oil and fuel (only with strip insert)			

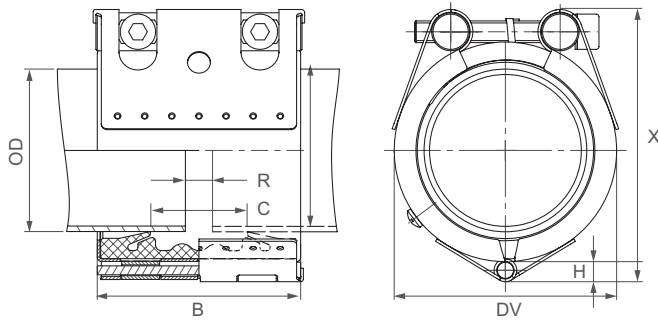

OD [mm]	High H [mm]
48.3 - 60.3	7.0
73.0 - 114.3	9.0
127.0 - 168.3	9.5



OD [mm]	Clamping range [mm]	PN [bar]	PN [bar]	B [mm]	C [mm]	DV [mm]	X [mm]	R without strip insert [mm]	R with strip insert [mm]	Torque rate [Nm]
48.3	47.0 - 49.5	25.0	16.0	75	35	70	89	5	15	7.5
54.0	52.5 - 55.5	25.0	16.0	75	35	76	94	5	15	7.5
57.0	55.5 - 58.5	25.0	16.0	75	35	79	97	5	15	7.5
60.3	59.0 - 61.5	25.0	16.0	75	35	82	101	5	15	7.5
73.0	71.5 - 74.5	25.0	16.0	94	51	95	119	5	25	10
76.1	74.5 - 77.5	25.0	16.0	94	51	98	123	5	25	10
84.0	82.5 - 85.5	25.0	16.0	94	51	106	131	5	25	10
88.9	87.5 - 90.5	25.0	16.0	94	51	111	136	5	25	10
100.6	99.0 - 102.5	25.0	16.0	94	51	123	148	5	25	10
101.6	100.0 - 103.5	25.0	16.0	94	51	124	148	5	25	10
104.0	102.5 - 105.5	20.0	16.0	94	51	126	152	5	25	10
104.8	103.0 - 106.5	20.0	16.0	94	51	127	152	5	25	10
108.0	106.5 - 109.5	20.0	16.0	94	51	130	156	5	25	10
114.3	112.5 - 116.0	20.0	16.0	94	51	136	162	5	25	10
118.0	116.0 - 120.0	20.0	16.0	94	51	140	166	5	25	10
127.0	125.0 - 129.0	20.0	16.0	107	62	149	179	5	35	12
129.0	127.0 - 131.0	20.0	16.0	107	62	151	181	5	35	12
130.2	128.5 - 132.0	20.0	16.0	107	62	152	181	5	35	12
133.0	131.0 - 135.0	16.0	16.0	107	62	155	189	5	35	12
139.7	138.0 - 141.5	16.0	16.0	107	62	162	192	5	35	12
141.3	139.5 - 143.0	16.0	16.0	107	62	163	192	5	35	12
154.0	152.0 - 156.0	16.0	16.0	107	62	176	207	5	35	12
159.0	157.0 - 161.0	16.0	16.0	107	62	181	212	5	35	12
168.3	166.0 - 170.5	16.0	16.0	107	62	190	225	5	35	12

Remarks:

- Follow fitting instructions
- PN () = working pressure considering the application loads
Test pressure = PN () x 1.5 (for example industry, water supply etc.)
PN () = nominal pressure, includes four times safety factor (e.g. shipbuilding)
- Strip inserts are optional accessories (see Technical Manual STRAUB)
- Additional sealing sleeves, pressure and temperature ranges on request