

## STRAUB-STEP-FLEX 2 | $\varnothing$ 219.1 - 812.8 mm

Components / Materials	W1	W2	W4	W5
Casing	S355MC, hot-dip galvanised	AISI 316 L or similar		AISI 316 L or similar
Bolts	AISI 4135	AISI 4135		A4 - 80
Bars	AISI 12L14, galvanised	AISI 12L14, galvanised		AISI 316 L or similar
Strip insert	AISI 316 L or similar	AISI 316 L or similar		AISI 316 L or similar

**Sealing sleeve**  
**EPDM** Temp.: -20°C up to +100°C  
 Medium: all qualities of water, waste water, air, solids and chemical products

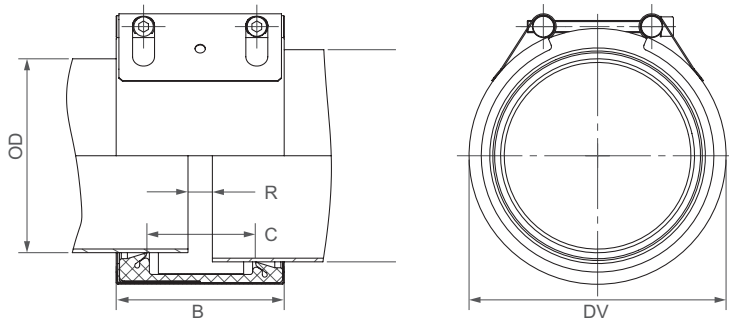

DV  $\Rightarrow$  OD + 27 mm  
 C  $\Rightarrow$  91 mm  
 R with strip insert  $\Rightarrow$  35 mm  
 R without strip insert  $\Rightarrow$  10 mm

	W2 or W5
	W1, W2 or W5
	W1 or W5
	only in W1 available



OD 1 [mm]	OD 2 min (OD 1 + 10mm) [mm]	OD 2 max (OD 2 + 30mm) [mm]	PN					
			2.5	6	10	16	20	25
219.1	230	250						
250.0	260	280						
267.0	277	297						
273.0	283	303						
304.0	314	334						
323.9	334	354						
355.6	366	386						
406.4	416	436						
457.2	467	487						
508.0	518	538						
558.8	569	589						
609.6	620	640						
711.2	721	741						
762.0	772	792						
812.8	823	843						

CONTINUOUSLY VARIABLE INTERMEDIATE SIZES FROM 219.1 TO 812.8 mm ARE AVAILABLE

### Remarks:

- Follow fitting instructions
- PN = working pressure considering the application loads  
 Test pressure = PN x 1.5 (for example industry, water supply etc.)
- Stainless steel strip insert included
- Additional sealing sleeves, pressure and temperature ranges on request