

STRAUB-FLEX 3.5 | \varnothing 323.9 - 1219.2 mm

Components / Materials	W1	W2	W4	W5
Casing	S355MC, hot-dip galvanised			AISI 316 L or similar
Bolts	AISI 4135			A4 - 80
Bars	AISI 12L14, galvanised			AISI 316 L or similar
Strip insert	AISI 316 L or similar / HDPE			AISI 316 L or similar / HDPE
Sealing sleeve EPDM	Temp.: -20°C up to +100°C Medium: all qualities of water, waste water, air, solids and chemical products			
Sealing sleeve NBR	Temp.: -20°C up to +80°C Medium: water, gas, oil, fuel and other hydrocarbons			

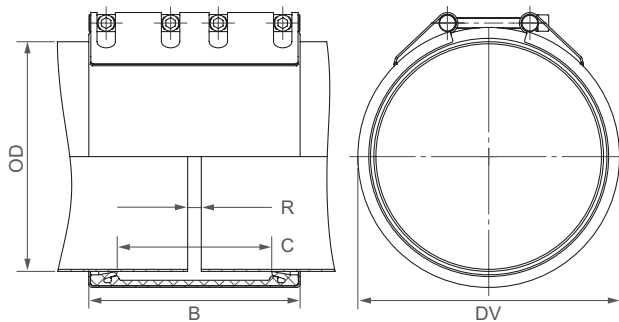

B \Rightarrow 310 up to 311 mm
 DV \Rightarrow OD + 38 mm
 C \Rightarrow 227 mm
 R with strip insert \Rightarrow 120 mm
 R without strip insert \Rightarrow 20 mm

	W1 or W5
	only in W5 available

OD [mm]	Clamping range [mm]	PN					
		2.5	6	10	16	20	25
323.9	320 - 327						
355.6	352 - 370						
406.4	402 - 410						
457.2	453 - 461						
508.0	504 - 512						
558.8	555 - 563						
609.6	605 - 614						
655.0	651 - 659						
711.2	707 - 715						
762.0	758 - 766						
812.8	809 - 817						
914.4	910 - 918						
1016.0	1011 - 1021						
1117.6	1112 - 1123						
1219.2	1214 - 1224						

CONTINUOUSLY VARIABLE INTERMEDIATE SIZES FROM 323.9 TO 1219.2 mm ARE AVAILABLE

Remarks:

- Follow fitting instructions
- PN = working pressure considering the application loads
Test pressure = PN x 1.5 (for example industry, water supply etc.)
Burst pressure = approx. PN x 2
- Strip inserts included
- Additional sealing sleeves, pressure and temperature ranges on request

\Rightarrow Bigger diameters are available as STRAUB-OPEN-FLEX