

PROTEGO® Spring-Loaded Pressure/Vacuum Relief Valves

Maintenance-friendly design

The cartridge design of PROTEGO® spring-loaded valves is particularly maintenance friendly.

This saves time and thus money.

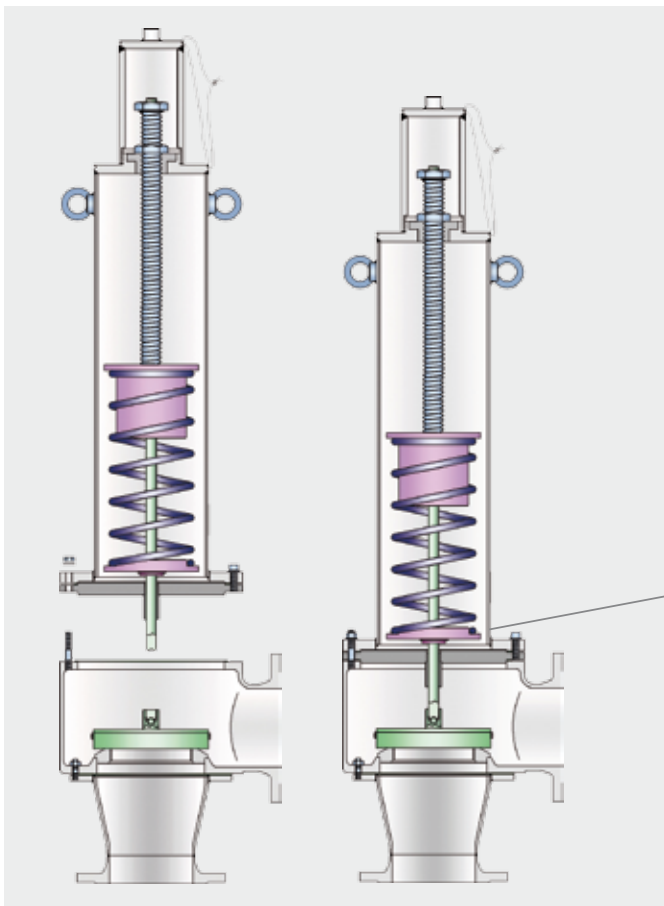

Requirement

Due to the number of components in the spring housing, maintenance can be difficult and time consuming. On completion of each maintenance job, readjustment of the spring tension on a test stand is required.

Solution

PROTEGO® developed a cartridge design for the spring housing. This enhances maintenance; the spring may now be left at its factory setting during maintenance.

PROTEGO® D/PAL-FS

Left: **disassembled** - ready for maintenance

Right: **assembled** - ready for service



for safety and environment

Benefits of cartridge design

- Compact and modular.
- Easier valve inspection means faster turn around time.
- Cartridge design isolates the spring and associated components, so the factory pressure setting is maintained.
- Vents can be inspected and maintained on site, since accidental changes to spring tension are avoided.

Operation limits

Pressure

- DN 150 +1000 mbar to +2000 mbar
- DN 200 + 600 mbar to +1000 mbar
- DN 250 + 400 mbar to +1000 mbar
- DN 300 + 300 mbar to +1000 mbar

Vacuum

- DN 200 - 600 mbar to - 900 mbar
- DN 250 - 400 mbar to - 900 mbar
- DN 300 - 300 mbar to - 900 mbar

Pressure relief valves

- e.g. DZ/E-FS, DZ/T-FS, D/PA(L)-FS

Vacuum relief valves

- e.g. SV/E-FS, SV/E-1-0-FS

Pressure and vacuum relief valves

- e.g. DV/ZT-FS, DV/ZU-FS, DV/ZW-FS

Other valve types are available on request.



PROTEGO® DZ/E-FS

PROTEGO® Head Office

Braunschweiger Flammenfilter GmbH

Industriestrasse 11

D-38110 Braunschweig

phone: +49 (0) 5307 / 809-0

fax: +49 (0) 5307 / 78 24

email: office@protego.com

web: www.protego.com



for safety and environment