

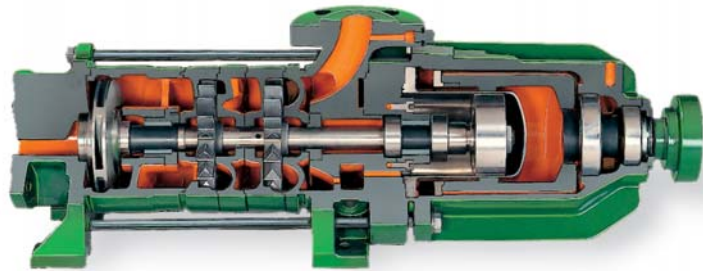

**DICKOW
PUMPEN**



**Sealless Magnetic Coupled, Heavy Duty
Side-Channel Pumps
Type SCM – PN40**

*our
contribution
for
environmental
protection*

General

The DICKOW-pump, type SCM, is a selfpriming horizontal side-channel pump with magnetic coupling. The side-channel pump with its high differential head has the advantage of operating more economical than normal centrifugal pumps for low capacities and high heads.

Due to these facts, the side-channel pumps are appropriate to solve many pumping problems in chemical and petrochemical industries.

The SCM-pump is a heavy duty pump for handling clean liquids without solids. Sealless magnetic driven pumps are designed to improve plants and personnel safety, especially when handling toxic, explosive or other dangerous liquids which react on contact with the atmosphere. For all such services, the static containment shell replaces double acting mechanical seals with external fluid reservoirs or barrier fluid circulating systems.

Due to the fact that 90 % of pump failures and required maintenance are caused by leaking mechanical seals, the sealless design will save maintenance and spare parts costs remarkably. Consider the reduction of the total costs of ownership.

The maximum allowable operating temperature is 180 °C (356 °F), higher temperatures are available on request.

Design

The SCM-pumps are single or multistage, side-channel pumps in heavy duty design with end suction and vertical discharge flanges. Flanges and casings are designed for a working pressure of 40 bar. The containment shells are sized according to operating pressure. The pump shaft is driven via a permanent magnetic coupling. The static containment shell forms a closed system with hermetically sealed liquid end.

Diffuser

The diffuser is designed as a retaining stage to avoid coasting of the pump during shut down. Sufficient liquid remains in the pump and enables a restart without problems.

Side-channel impellers / SiC insert rings

The rotating star-shaped side-channel impellers are fitted in a chamber between the suction and pressure disks and keyed to the pump shaft in floating position. No hydraulic thrust loads exist.

To achieve selfpriming capability, best efficiency and rated differential pressure, tight clearances between the rotating impeller and the stationary disks are required.

During operation with properly filled pump, a stable fluid film between the impellers and the disks will center the impeller in the chamber and avoid metallic contact between rotating and stationary parts, seizing of the impellers.

When pump is running dry however and when handling volatile liquids with low viscosities, this fluid film will not be available or will not offer the required stability to avoid metallic contact and seizing of the impellers.

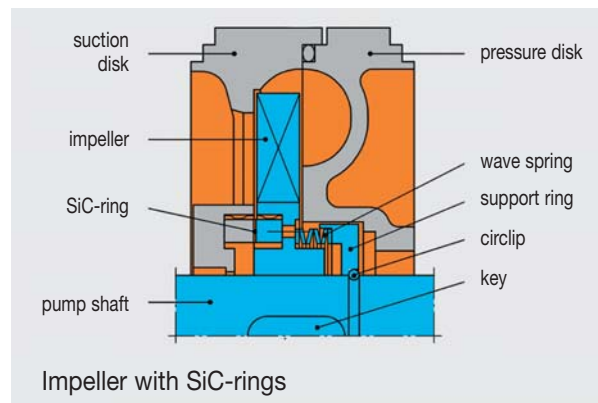

To increase availability and to avoid seizing of the impellers in any case, the pumps can be fitted with additional SiC-rings as an option.

The SiC-rings are placed in the suction disk as well as in the impeller hub. The impeller ring will be pushed concentric to the ring in the suction disk by a spring and the support ring. Metallic contact between the rotating and stationary parts and seizing of the impeller are therefore excluded.

Sectional drawing

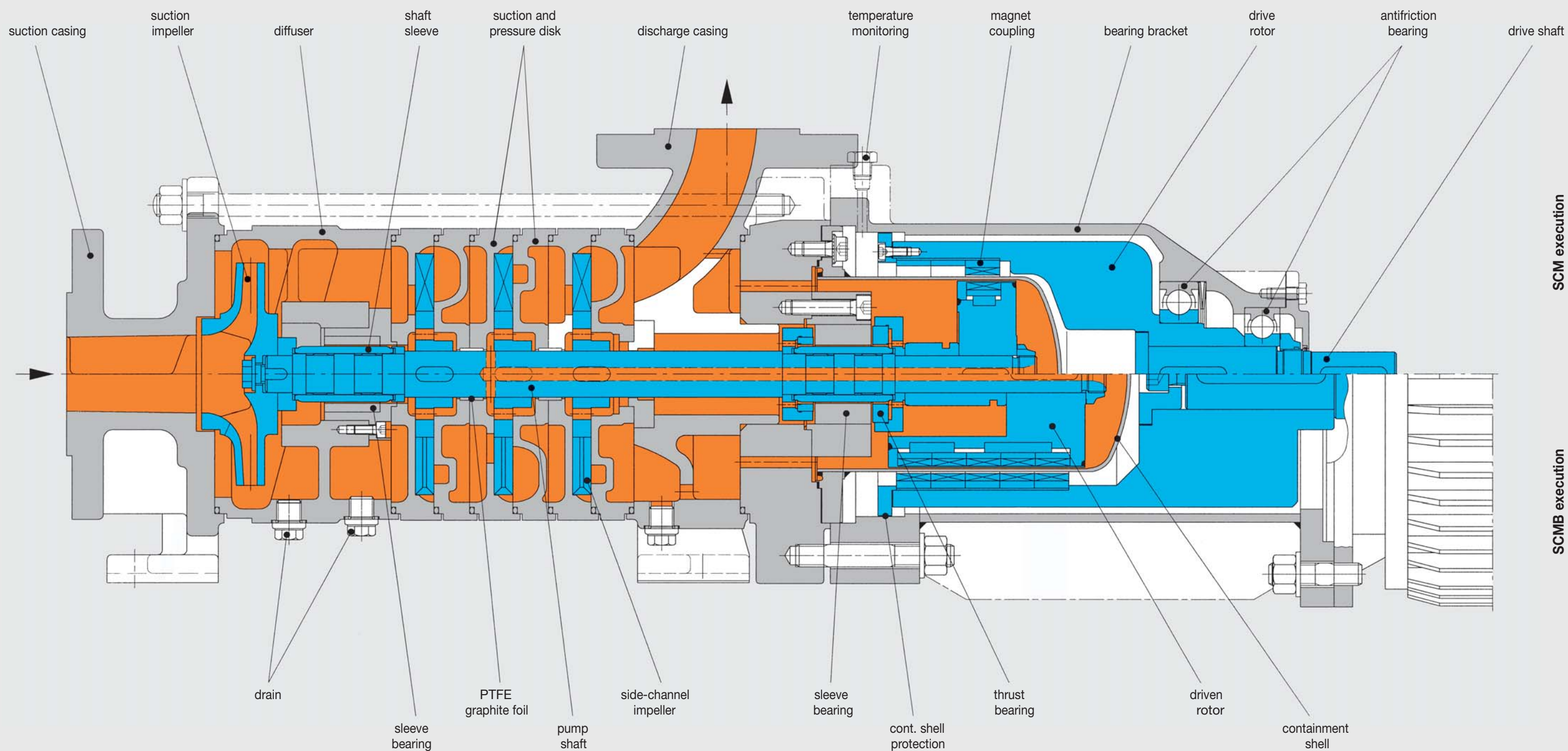

Standard materials:

Suction and discharge casing, diffuser	EN-GJS-400-18-LT, 1.4408
Suction and pressure disk	EN-GJS-400-18-LT, 1.4408 (G-X5 CrNiMo 18.10)
Suction impeller	EN-GJL-250, 1.4408 (G-X5 CrNiMo 18.10)
Side-channel impellers	1.4517 (G-X2 CrNiMoCuN 25-6-3-3)
Pump shaft	1.4021 (X20 Cr13), 1.4571 (X10 CrNiMoTi 18.10)

Sleeve bearing, shaft sleeve	SiC dry safe coated
Thrust bearing	SiC
Bearing bracket	EN-GJS-400-18-LT
Containment shell	2.4610 (Hastelloy C-4)
Permanent magnet	Cobalt Samarium $S_{m2}CO_{17}$

Suction and pressure disks

The suction and pressure disks are sealed to the atmosphere by confined O-rings with metal to metal fit, to prevent blow outs. In the shaft area, floating graphite impregnated PTFE-inserts are located in the disks to reduce shaft deflection and wear. The differential head is built up in the side-channel of the pressure disk.

Pump shaft

The rigid pump shaft is carried by sleeve bearings, positioned in the pumped liquid. The generously dimensioned shaft diameter reduces deflection and ensures minimum torsional loads.

Outer ball bearings

The outer rotor with the drive shaft is positioned in generously dimensioned grease lubricated ball bearings.

Oil lubricated bearing bracket and close coupled execution are available as an option.

Sleeve bearings, shaft sleeve

The stationary sleeve bearings, the rotating shaft sleeve and the thrust bearing are made of pure wear resistant SiC. The shaft sleeves are fitted to the pump shaft by metallic tolerance rings to avoid thermal stress.

Suction impeller / NPSH-values

To achieve low NPSH-conditions, a centrifugal impeller with enlarged eye area is located on suction side. The NPSH-values are based on water at 20 °C (65 °F). When handling boiling liquids, the required liquid level on suction side can be reduced to approximately 50 % of these NPSH-values.

Magnet coupling

The single elements of the multipolar magnet coupling are manufactured of permanent magnet material "Cobalt Samarium" with unlimited lifetime. The magnets in the driven rotor are completely encapsulated, not in contact with liquid.

Power is transmitted to the hermetically sealed liquid end by a bank of external magnets. Inner and outer magnet rings are locked together by magnet forces and work as a synchronous coupling. The inner magnet ring transmits the required torque direct to the impeller. Overload of the magnet coupling and slipping will not cause demagnetization if temperature monitoring is available.

Internal circulation

When the pump is in operation, it generates eddy currents which heat up the containment shell and the product in the magnet area. This heat is dissipated by an internal circulation. The circulation flow is led from discharge through the magnet area and the pump shaft to the suction disk of the last stage.

Monitoring

Connection for temperature sensor for containment shell surface is available as standard. Dry running protection, monitoring of ball bearings and pump protection with the patented "mag-safe" system is highly recommended.

Containment shell protection

The clearances between the drive rotor and the bearing bracket, respectively the motor support lantern, and between the drive magnets and the containment shell are arranged such that rubbing of the magnets on the containment shell will be avoided even in the case of worn out ball bearings.

Hazardous area

Together with the required Ex-drive motors, the SCM-pumps can be applied in hazardous area Group II, Category 2. The pumps meet the basic safety and health requirements of Explosion-proof Directive 94/9 EC and are suitable for plants with increased safety requirement.

Performance range SCM

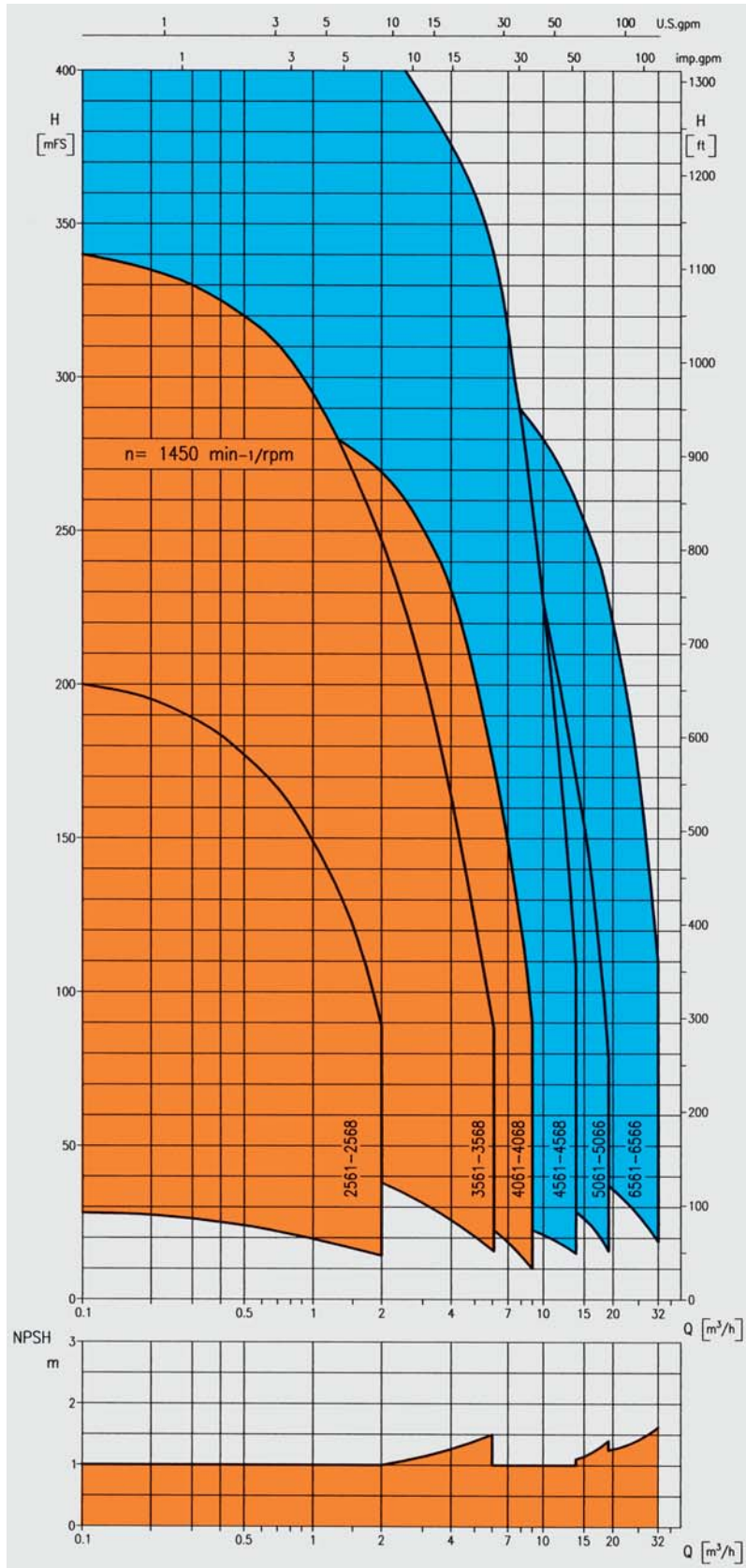

Performance curves of the individual pump sizes, also for 1750 rpm, with NPSH-values and power consumption are available on request.

