



**DICKOW
PUMPEN**



**Multistage Submerged
Centrifugal Pumps
Type HZV**

General, applications

The DICKOW vertical submersible long shaft pump is a one or multistage centrifugal pump. The performance range covers capacities up to 500 m³/h (2200 USgpm) and differential heads up to 400 mLC (1310 ft) and is subdivided such that best efficiency is granted at all service conditions.

With a wide selection of materials, several design options and shaft sealing systems, the HZV pumps are suitable for handling almost all kinds of liquids which are free of abrasive solids and of suitable viscosity.

Common applications are unloading of fuels and solvents from underground tanks, e.g. for kerosine respectively jet fuel in hydrant systems for aircraft refuelling (Cat.1-design) and pumping condensate or ammonia (barrel casing design).

Design

Hydraulic pump part

The hydraulic pump parts are located in the pumping fluid respectively in the tank. The pump parts consist of suction and discharge casing, intermediate casings, diffusers and impellers. The discharge casing is bolted to the bottom column pipe. The closed impellers are hydraulically balanced by balance holes and wear rings to keep the thrust loads as small as possible.

Support columns

The support columns are made of seamless steel tube with welded neck connection flanges. The number of column pipes is determined by the submerged length and the pump speed.

Pump shaft, column shaft(s), drive shaft

The complete shaft consists of the pump shaft, one or more column shafts and the drive shaft. The single shafts are rigidly connected through screwed sleeve couplings.

The maximum lengths of the column shafts comply with the recommendations of the API 610 and are dimensioned to guarantee subcritical speed characteristics throughout the whole operating range.

Sleeve coupling

The all-metal sleeve coupling consists of the sleeve, the lock nuts and the fixing screws.

The power is transmitted via the keys, the sleeve is fixed vibration-free and secured by the lock nuts. The distance "a" between the shaft ends can be adjusted.

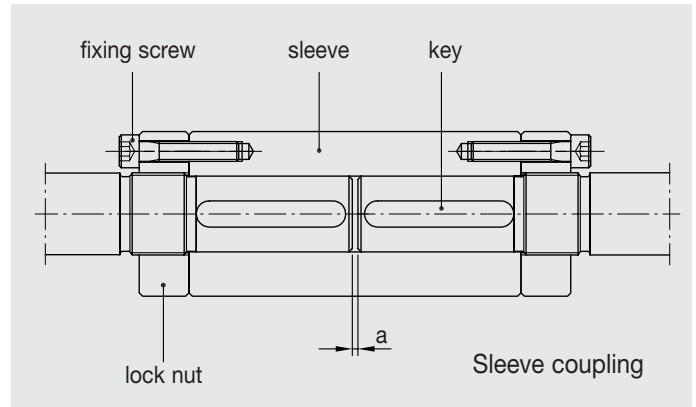

Guide bearings, sleeve bearings

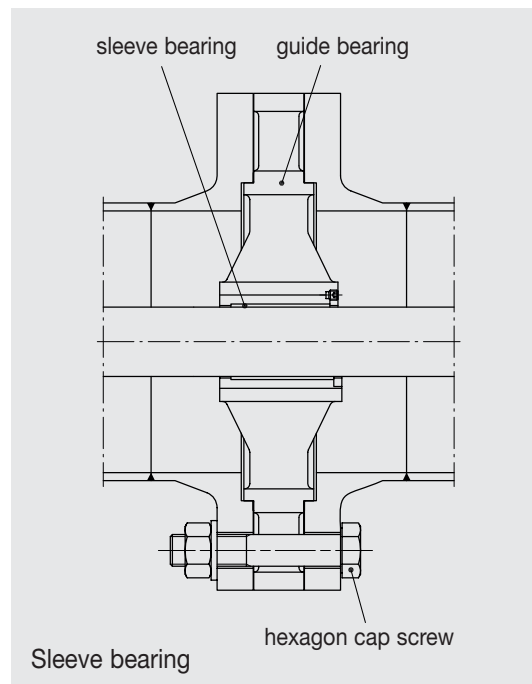

The guide bearings are positioned by centrings in the column shafts and tightened by hexagon cap screws. The sleeve bearing is located in the hub of the guide bearing. Standard bearing material for clean liquids is sintered Graphite-Teflon foil. The bearing foil is of floating design and has dry running capability.

When handling liquids with abrasive solids, wear-resistant SiC-sleeve bearings can be installed.

Drive lantern (motor support)

The drive lantern is a welded construction of seamless steel tube. Discharge flange, motor hub flange and the flange for connection to the dome cover are welded to the drive lantern. Shaft sealing and antifriction bearings are also located in the drive lantern.

Dome cover (mounting flange)

Standard material of the dome cover is carbon steel. Stainless steel material 1.4571 (ASME SS 316) is available on request. The dome covers are generally made according to the mounting flange dimensions of the tank, as long as they can accommodate the outer diameter of the pump body.

If the tanks are pressurized, the covers will be sized and manufactured according to the applicable requirements.

Barrel casing

For handling boiling liquids (e.g. condensate) and if very low NPSH-values are required, the HZV-pump with barrel casing is available.

Dimension "H" is determined as follows:

$$H = \text{NPSHR} - \text{NPSHA} + 0,5 \text{ m}$$

(NPSHR – acc. to performance curve, 0,5 m is safety margin)

Antifriction bearings

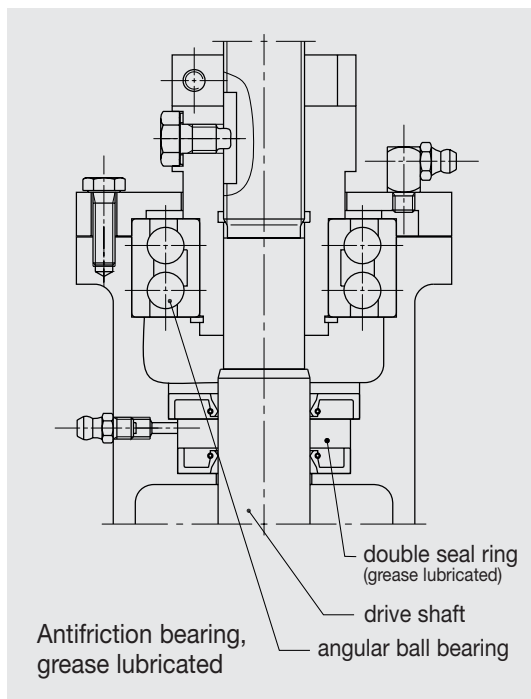

The drive shaft is fixed axially through a grease-lubricated, double-row angular ball bearing. This ball bearing carries the rotor weight and the residual thrust loads. A grease lubricated double seal ring protects the bearing from shaft sealing leakage.

To increase bearing running time (MTBF) the bearings can also be offered with oil lubrication.

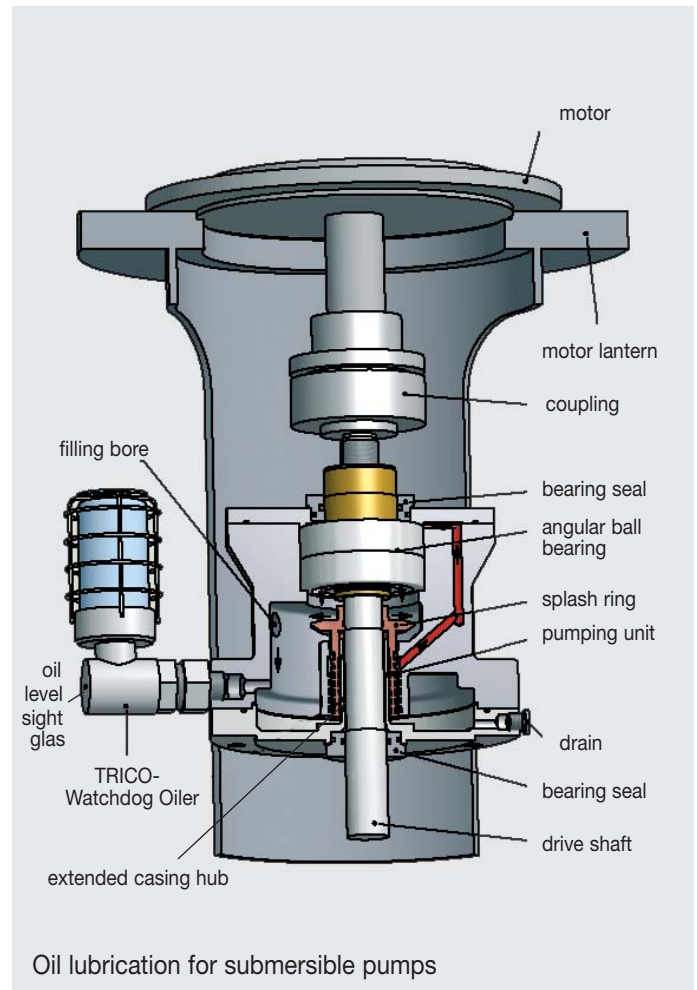

Motor, coupling

The motor is connected to the drive lantern above the dome cover. IEC-motors of design V1 are used as standard. NEMA-motors with US-dimensions can be used as an option.

The motors are connected to the drive shaft with a suitable coupling. If spacer-type couplings are used, repair works on bearings and shaft sealing can be carried out without removal of the motor.

Sectional drawings

HZV standard design

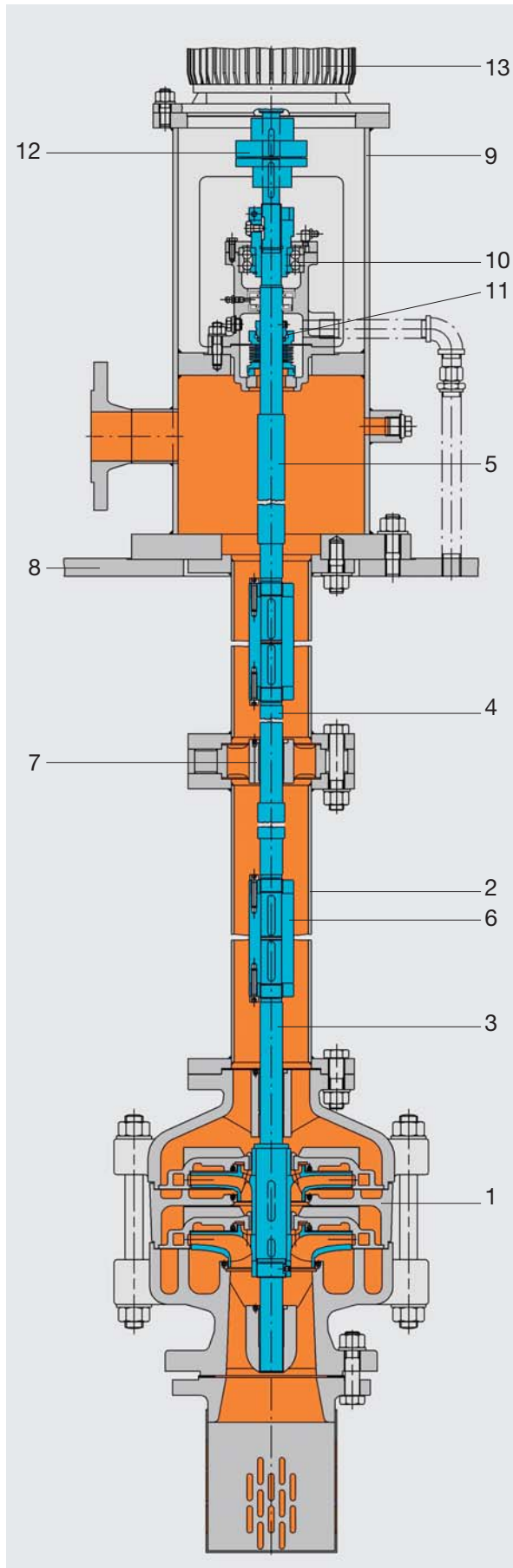

HZV barrel-casing design

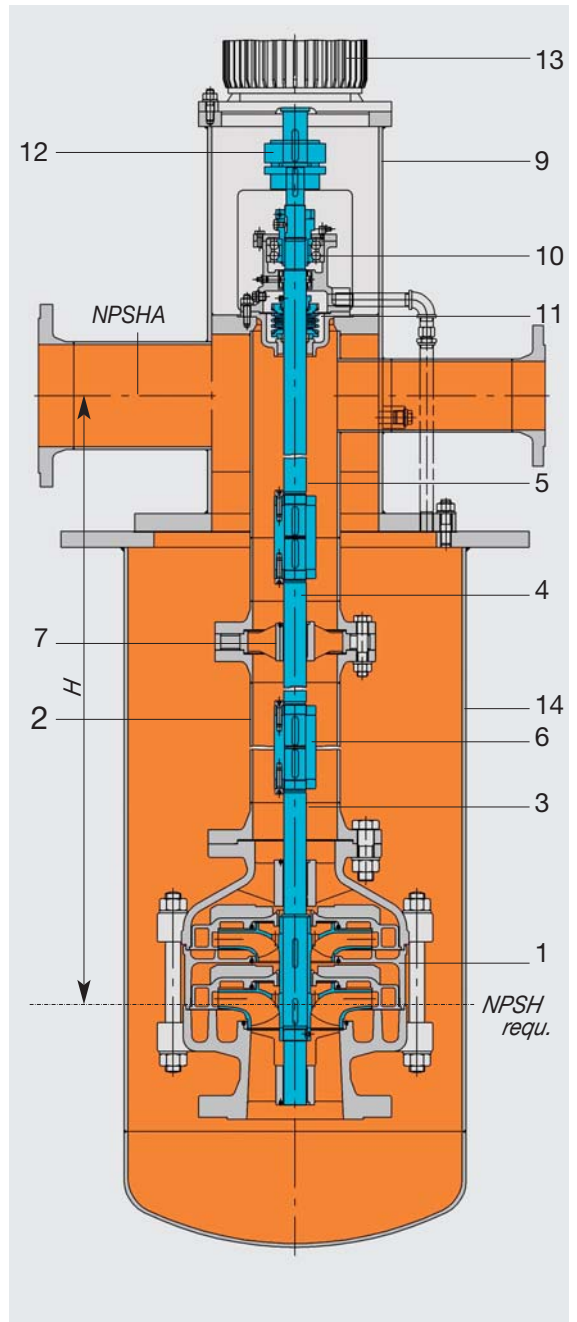

List of components

- | | |
|-----------------------|-------------------------|
| 1 Hydraulic pump part | 8 Dome cover |
| 2 Column pipe | 9 Drive lantern |
| 3 Pump shaft | 10 Antifriction bearing |
| 4 Column shaft | 11 Shaft sealing |
| 5 Drive shaft | 12 Coupling |
| 6 Sleeve coupling | 13 Drive motor |
| 7 Guide bearing | 14 Barrel casing |

HZV Cat.1/V design

General, field of application

The submersible pumps of series HZV-Cat.1 are suitable for pumping inflammable, highly inflammable and extremely inflammable liquids out of Zone 0 (e.g. underground tanks, vessels), provided that these liquids belong to explosion group IIA and to temperature class T1 to T4. The compliance with the basic safety and health requirements for design and manufacture of these submersible pumps for the defined use in hazardous areas acc. to Annex II of the Explosion Proof Directive 94/9/EC is confirmed by a type approval of the German notified body PTB.

Pump designation acc. to ATEX:
ExII1/2 Gc/bIIBT4

The required safety features are:

Casing material

The pressurized parts of the hydraulic pump part, suction and discharge casings and intermediate casings are made of cast steel GP 240 GH, respectively of stainless steel 1.4408.

Flow switch

The flow detector is flanged to the discharge flange of the pump. If the capacity falls below the required minimum flow, the flow detector will shut-off the pump via a relay.

Level switch

The level switch shuts-off the pump if liquid level falls below minimum allowable level.

PT100 temperature monitor

The PT100 monitors the temperature of the pump casing and detects overheating through upset conditions.

Drive motors

Motors must be ATEX approved.

Cat.1/V accessories

- 15 Flow switch
- 16 Level switch
- 17 PT100 temperature monitor

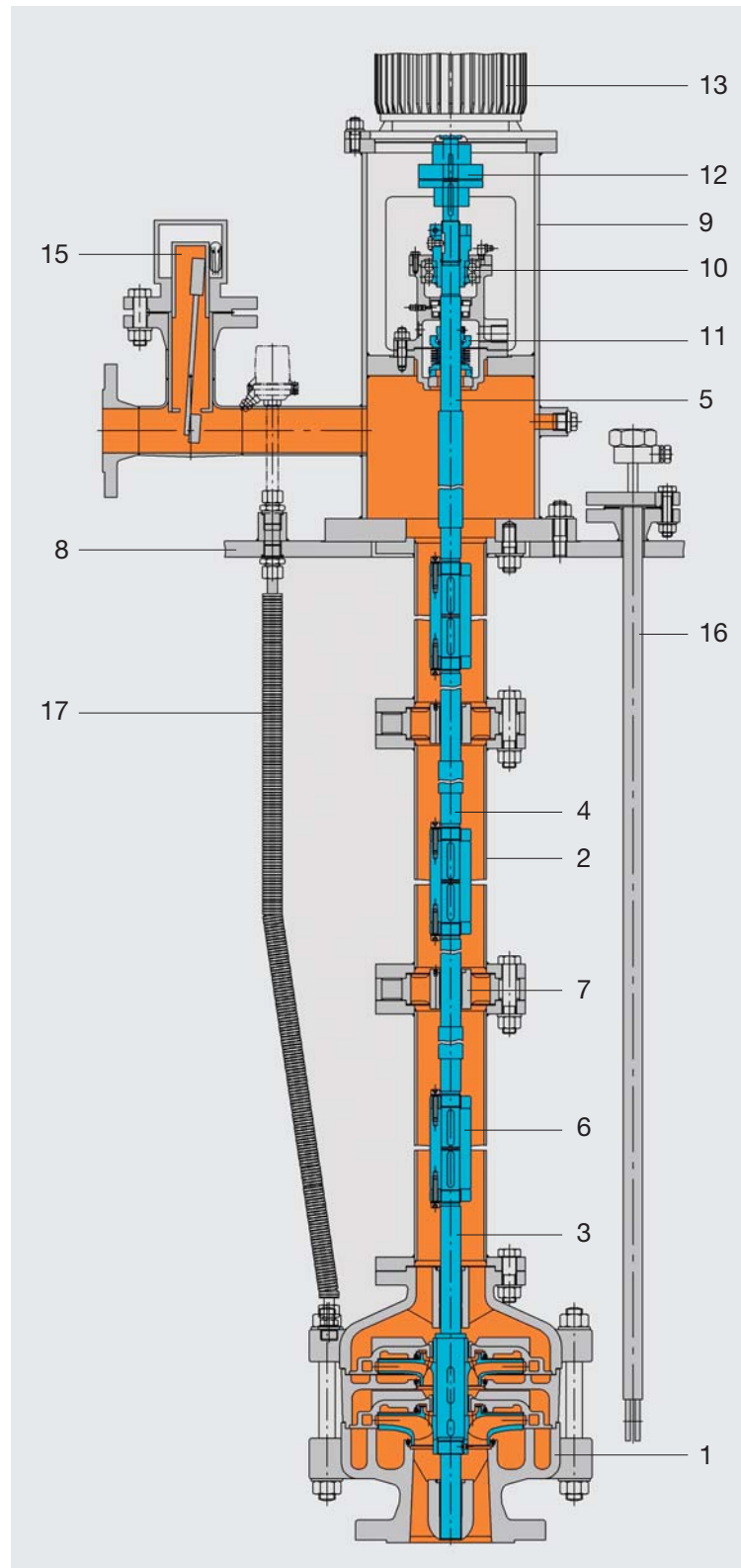

Alternative pump designs acc. to API 610:

Pump type VS1

Vertically suspended, single-casing diffuser pumps with discharge through the column
DICKOW type **HZVR**



Pump type VS6

Double casing, vertically suspended pumps (barrel type)
DICKOW type **HZVR**



Shaft sealing systems

Gland packings and all common mechanical seals can be fitted.

Design "N10"

Single metal bellows mechanical seal, system DICKOW N10.
Circulation dead end, cooled by liquid handled, pressure max. 10 bar.

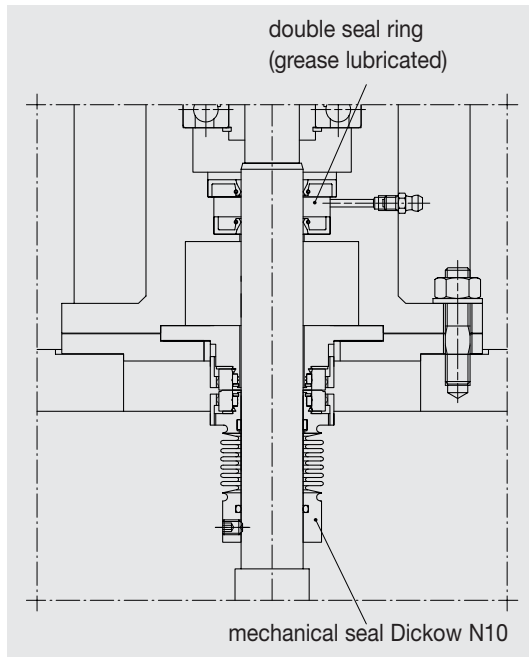

Design "Re"

Single balanced elastomer mechanical seal.
Circulation dead end, cooled by liquid handled.

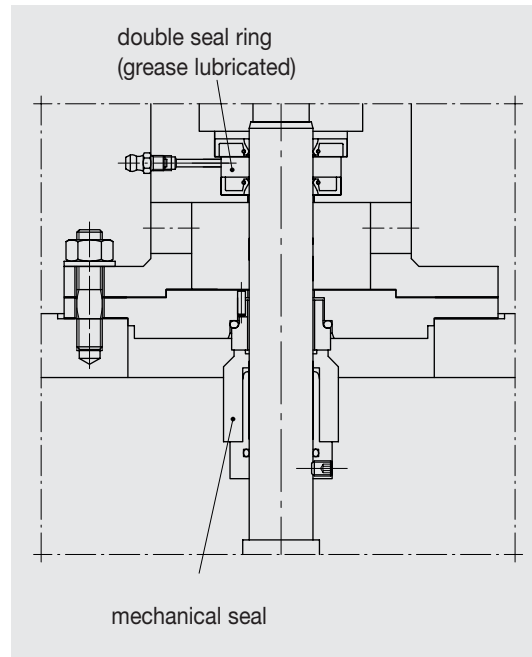

Design "Cartd"

Double mechanical seal, Cartridge design.
Circulation acc. to API Plan 52/53.

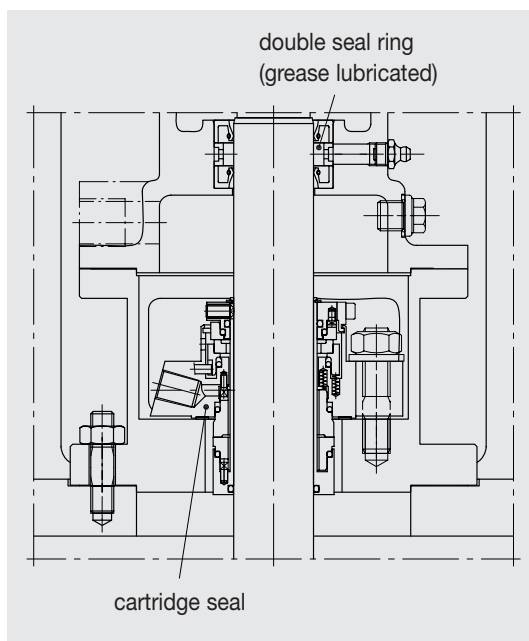

Design "C2A3A53"

Double mechanical seal acc. to API 682,
Cartridge design.
Circulation acc. to API Plan 53.

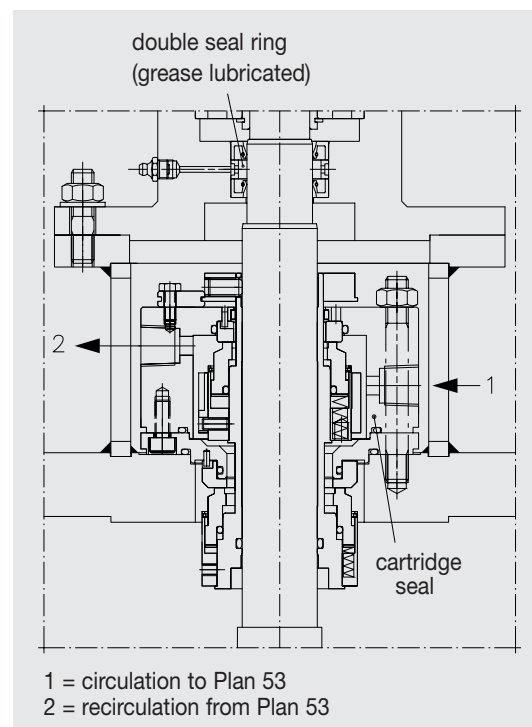

Performance range HZV

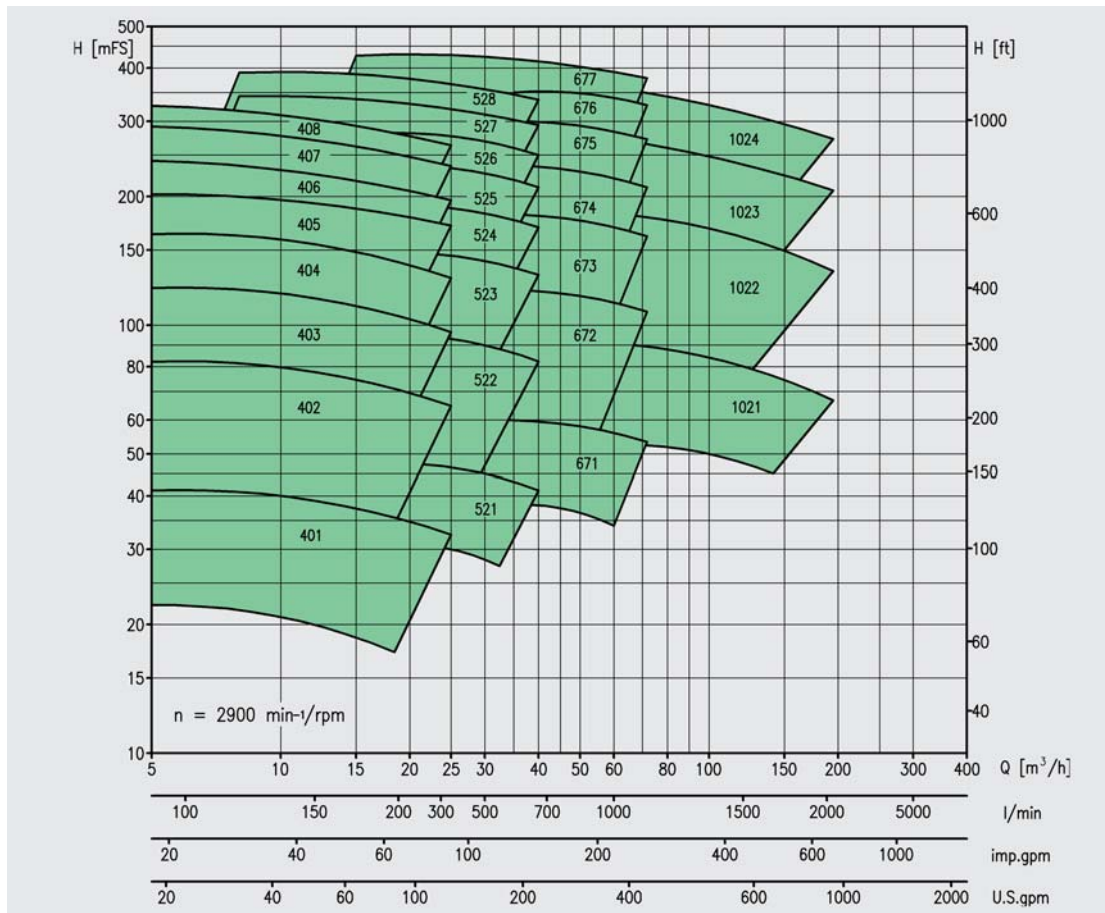
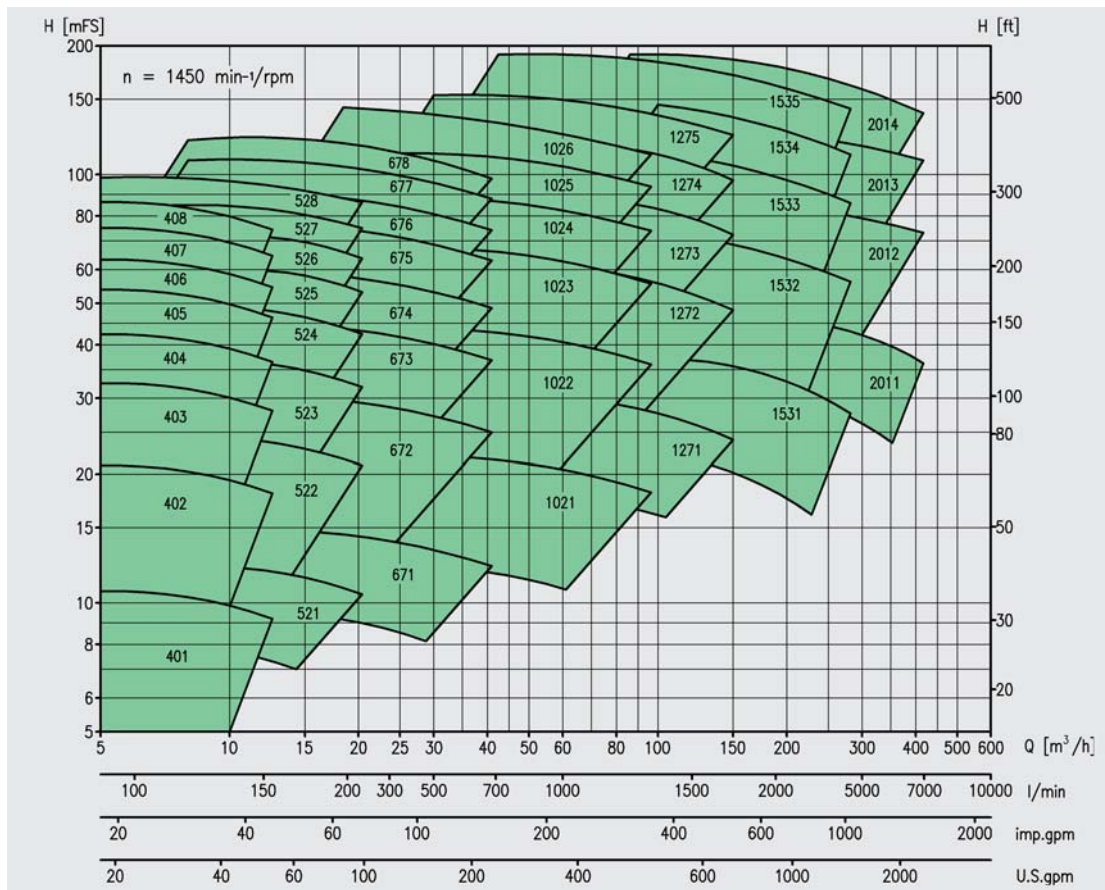

Performance curves of the individual pump sizes, also for 1750 / 3500 rpm, with NPSH-values and power consumption, are available on request.

DICKOW PUMPEN GmbH & Co.KG
 P.O. Box 1254
 84465 Waldkraiburg · Germany
 Phone ++ 49 86 38 6 02 0
 Fax ++ 49 86 38 6 02 200 + 6 02 201
 info@dickow.de / export@dickow.de
 www.dickow.de

