

STRAUB-METAL-GRIP-FIRE-FENCE | \varnothing 30.0 - 219.1 mm

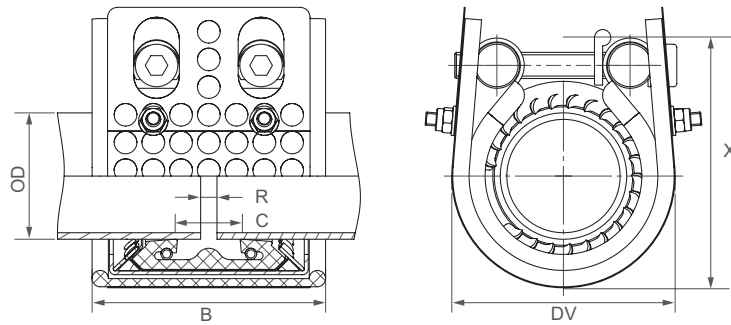

Components / Materials	W1	W2	W4	W5
Casing		AISI 316 L	AISI 316 L	AISI 316 L or similar
Bolts		AISI 4135	A4 - 80	A4 - 80
Bars		AISI 12L14, galvanised	AISI 304	AISI 316 L or similar
Anchoring rings		AISI 301	AISI 301	AISI 301
Strip insert (option)		AISI 316 L or similar / PVDF	AISI 316 L or similar / PVDF	AISI 316 L or similar / PVDF
Sealing sleeve EPDM	Temp.: -30°C up to +100°C Medium: all qualities of water, waste water, air, solids and chemical products			
Sealing sleeve NBR	Temp.: -20°C up to +80°C Medium: water, gas, oil, fuel and other hydrocarbons			



OD [mm]	Clamping range [mm]	PN [bar]	PN [bar]	B [mm]	C [mm]	DV [mm]	X [mm]	R without strip insert [mm]	R with strip insert [mm]	Torque rate [Nm]	Allen head [mm]	Thread M...
30.0	29.5 - 30.5	67.0	16.0	46/67	18	57	61	5	5	10	6	8
33.7	33.2 - 34.2	62.0	16.0	46/67	18	62	68	5	5	10	6	8
38.0	37.5 - 38.5	58.0	16.0	71	19	68	78	5	5 - 10	15	6	8
42.4	41.9 - 42.9	53.0	16.0	71	20	72	81	5	5 - 10	15	6	8
44.5	44.0 - 45.0	48.0	16.0	71	20	74	85	5	5 - 10	15	6	8
48.3	47.8 - 48.8	44.0	16.0	71	20	78	88	5	5 - 10	15	6	8
54.0	53.5 - 54.5	39.0	16.0	87	38	84	94	5	5 - 15	15	6	8
57.0	56.4 - 57.6	37.0	16.0	87	32	87	97	5 - 10	5 - 25	15	6	8
60.3	59.7 - 60.9	37.0	16.0	87	32	87	100	5 - 10	5 - 25	15	6	8
63.5	62.9 - 64.1	37.0	16.0	87	32	94	103	5 - 10	5 - 25	15	6	8
76.1	75.3 - 76.9	56.0	16.0	110	39	110	122	5 - 10	5 - 25	35	8	10
84.0	83.2 - 84.8	45.0	16.0	110	39	122	128	5 - 10	5 - 25	35	8	10
88.9	88.0 - 89.8	41.0	16.0	110	39	127	128	5 - 10	5 - 25	35	8	10
104.0	103.0 - 105.0	37.0	16.0	110	39	143	156	5 - 10	5 - 25	35	8	10
108.0	106.9 - 109.1	35.0	16.0	110	39	143	156	5 - 10	5 - 25	35	8	10
114.3	113.2 - 115.4	34.0	16.0	110	39	149	162	5 - 10	5 - 25	35	8	10
129.0	127.7 - 130.3	33.0	16.0	124	43	170	187	5 - 15	5 - 25	60	10	12
133.0	131.7 - 134.3	33.0	16.0	125	43	170	187	5 - 15	5 - 25	60	10	12
139.7	138.3 - 141.1	32.0	16.0	125	43	178	196	5 - 15	5 - 25	60	10	12
154.0	152.5 - 155.5	32.0	16.0	125	51	196	215	5 - 15	5 - 25	60	10	12
159.0	157.4 - 160.6	31.0	16.0	125	43	197	215	5 - 15	5 - 25	60	10	12
168.3	166.6 - 170.0	29.0	16.0	125	43	210	225	5 - 15	5 - 25	60	10	12
219.1	216.9 - 221.3	26.0	16.0	166	60	269	293	5 - 15	5 - 35	100	14	16

REFER TO MINIMUM WALL THICKNESS (see Technical Manual STRAUB)

Remarks:

- Follow fitting instructions
- PN () = working pressure considering the application loads
Test pressure = PN () x 1.5 (for example industry, water supply etc.)
PN () = nominal pressure, includes four times safety factor (e.g. shipbuilding)
- The pressure values are valid on radial rigid carbon steel pipes under static loads
- Additional sealing sleeves and temperature ranges on request

STRAUB-METAL-GRIP-FIRE-FENCE | ø 244.5 - 457.2 mm

Components / Materials	W1	W2	W4	W5
Casing	AISI A738, hot-dip galvanised			
Bolts	AISI 4135			
Bars	AISI 12L14, galvanised			
Anchoring rings	AISI 301			
Strip insert (option)	AISI 316 L or similar / PVDF			
Sealing sleeve EPDM	Temp.: -20°C up to +100°C Medium: all qualities of water, waste water, air, solids and chemical products			
Sealing sleeve NBR	Temp.: -20°C up to +80°C Medium: water, gas, oil, fuel and other hydrocarbons			

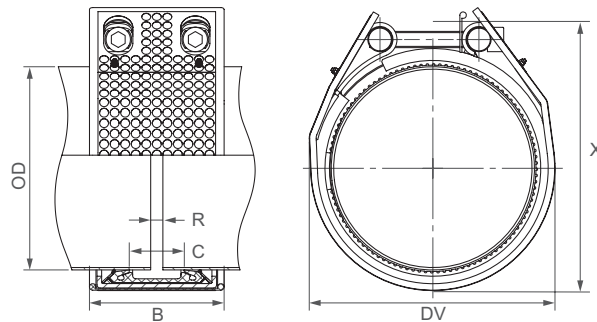

OD [mm]	Clamping range [mm]	PN [bar]	PN [bar]	B [mm]	C [mm]	DV [mm]	X [mm]	R without strip insert [mm]	R with strip insert [mm]	Torque rate [Nm]	Allen head [mm]	Thread M...
244.5	242.0 - 247.0	27.0	14.0	164	67	300	335	5 - 15	5 - 35	180	17	20
267.0	264.5 - 269.5	24.0	12.0	164	67	322	357	5 - 15	5 - 35	180	17	20
273.0	270.5 - 275.5	21.0	12.0	164	67	328	364	5 - 15	5 - 35	180	17	20
323.9	320.5 - 327.0	18.0	10.0	164	67	379	416	5 - 15	5 - 35	230	17	20
355.6	352.0 - 359.0	17.0	8.0	164	67	411	449	5 - 15	5 - 35	230	17	20
406.4	402.5 - 410.5	14.0	8.0	164	67	461	499	5 - 15	5 - 35	230	17	20
457.2	452.5 - 462.0	8.0	6.0	164	67	512	551	5 - 15	5 - 35	250	17	20

REFER TO MINIMUM WALL THICKNESS (see Technical Manual STRAUB)

Remarks:

- Follow fitting instructions
- PN (🏭) = working pressure considering the application loads
Test pressure = PN (🏭) x 1.5 (for example industry, water supply etc.)
PN (🚢) = nominal pressure, includes four times safety factor (e.g. shipbuilding)
- The pressure values are valid on radial rigid carbon steel pipes under static loads
- Strip inserts are optional accessories (see Technical Manual STRAUB)
- Additional sealing sleeves and temperature ranges on request

STRAUB-GRIP-FIRE-FENCE | \varnothing 25.0 - 168.3 mm

Components / Materials	W1	W2	W4	W5
Casing				AISI 316 L or similar
Bolts				A4 - 80
Bars				AISI 316 L or similar
Anchoring rings				AISI 301
Strip insert (option)				AISI 316 L / PVDF

Sealing sleeve EPDM	Temp.: -20°C up to +100°C	Medium: all qualities of water, waste water, air, solids and chemical products
Sealing sleeve NBR	Temp.: -20°C up to +80°C	Medium: water, gas, oil, fuel and other hydrocarbons
Sealing sleeve FPM/FKM	Temp.: -20°C up to +180°C	Medium: ozone, oxygen, acids, gas, oil and fuel (only with strip insert)

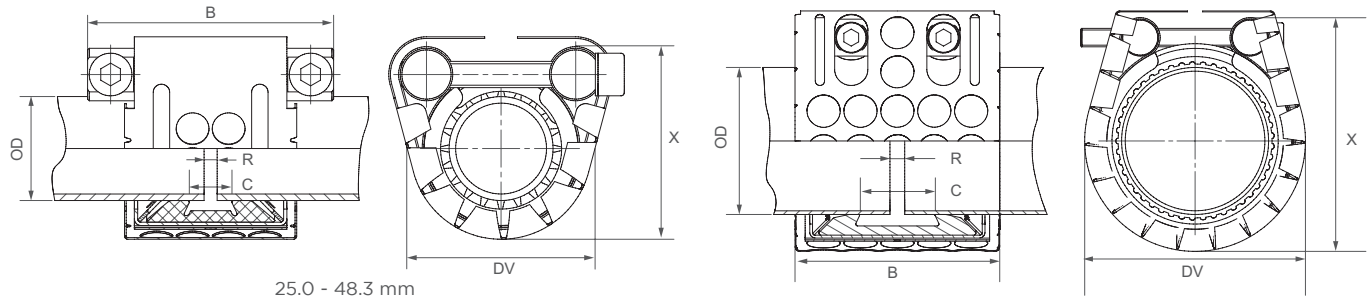



25.0 - 48.3 mm

54.0 - 168.3 mm



OD [mm]	Clamping range [mm]	PN [bar]	PN [bar]	B [mm]	C [mm]	DV [mm]	X [mm]	R without strip insert [mm]	R with strip insert [mm]	Torque rate [Nm]	Allen head [mm]	Thread M...
25.0	24.5 - 25.5	64.0	16.0	46.5 / 75	18	51	58	5	5 - 10	10	6	8
26.9	26.4 - 27.4	58.0	16.0	46.5 / 75	18	54	61	5	5 - 10	10	6	8
28.0	27.5 - 28.5	50.0	16.0	46.5 / 75	18	55	62	5	5 - 10	10	6	8
30.0	29.5 - 30.5	42.0	16.0	46.5 / 75	18	57	65	5	5 - 10	10	6	8
33.7	33.2 - 34.2	39.0	16.0	46.5 / 75	18	61	70	5	5 - 10	10	6	8
35.0	34.5 - 35.5	37.0	16.0	46.5 / 75	18	62	71	5	5 - 10	12	6	8
38.0	37.5 - 38.5	36.0	16.0	46.5 / 75	18	65	74	5	5 - 10	12	6	8
40.0	39.5 - 40.5	35.0	16.0	46.5 / 75	18	67	76	5	5 - 10	12	6	8
42.4	41.9 - 42.9	33.0	16.0	46.5 / 75	18	70	79	5	5 - 10	12	6	8
44.5	44.0 - 45.0	30.0	16.0	46.5 / 75	18	72	81	5	5 - 10	12	6	8
48.3	47.8 - 48.8	28.0	16.0	46.5 / 75	18	75	86	5	5 - 10	12	6	8
54.0	53.5 - 54.5	24.0	16.0	65	24	81	92	5	5 - 15	15	6	8
57.0	56.4 - 57.6	23.0	16.0	65	24	84	95	5	5 - 15	15	6	8
60.3	59.7 - 60.9	23.0	16.0	65	24	87	98	5	5 - 15	15	6	8
63.0	62.4 - 63.6	23.0	16.0	65	24	90	101	5	5 - 15	15	6	8
66.6	64.9 - 67.3	22.0	16.0	65	24	94	105	5	5 - 15	15	6	8
70.0	68.9 - 70.7	22.0	16.0	65	24	97	109	5	5 - 15	15	6	8
73.0	72.3 - 73.7	21.0	16.0	65	24	100	112	5	5 - 15	15	6	8
76.1	75.3 - 76.9	35.0	16.0	100	40	110	127	5 - 10	5 - 25	30	8	10
79.5	78.7 - 80.3	32.0	16.0	100	40	113	130	5 - 10	5 - 25	30	8	10
84.0	83.2 - 84.8	29.0	16.0	100	40	117	135	5 - 10	5 - 25	30	8	10
88.9	88.0 - 89.8	26.0	16.0	100	40	122	139	5 - 10	5 - 25	30	8	10
95.0	94.0 - 96.0	24.0	16.0	100	40	127	144	5 - 10	5 - 25	35	8	10
98.0	97.0 - 99.0	24.0	16.0	100	40	131	148	5 - 10	5 - 25	35	8	10
100.6	99.6 - 101.6	23.0	16.0	100	40	134	151	5 - 10	5 - 25	35	8	10
101.6	100.6 - 102.6	23.0	16.0	100	40	135	151	5 - 10	5 - 25	35	8	10
104.0	103.0 - 105.0	23.0	16.0	100	40	137	153	5 - 10	5 - 25	35	8	10
104.8	103.8 - 105.8	23.0	16.0	100	40	138	155	5 - 10	5 - 25	35	8	10
108.0	106.9 - 109.1	22.0	16.0	100	40	142	159	5 - 10	5 - 25	35	8	10
114.3	113.2 - 115.4	22.0	16.0	100	40	148	165	5 - 10	5 - 25	35	8	10
118.0	116.9 - 119.1	22.0	16.0	100	40	152	171	5 - 10	5 - 25	35	8	10
125.0	123.7 - 126.3	21.0	16.0	115	53	162	179	5 - 10	5 - 30	45	10	12
127.0	125.7 - 128.3	21.0	16.0	115	53	164	181	5 - 10	5 - 30	45	10	12
129.0	127.7 - 130.3	21.0	16.0	115	53	166	183	5 - 10	5 - 30	45	10	12
130.2	128.9 - 131.5	21.0	16.0	115	53	167	184	5 - 10	5 - 30	45	10	12
133.0	131.7 - 134.3	21.0	16.0	115	53	170	187	5 - 10	5 - 30	45	10	12
139.7	138.3 - 141.1	20.0	16.0	115	53	176	194	5 - 10	5 - 30	45	10	12
141.3	139.9 - 142.7	20.0	16.0	115	53	178	195	5 - 10	5 - 30	45	10	12
144.0	142.6 - 145.4	20.0	16.0	115	53	181	188	5 - 10	5 - 30	50	10	12
154.0	152.5 - 155.5	18.0	16.0	115	53	191	208	5 - 10	5 - 30	50	10	12
159.0	157.4 - 160.6	18.0	16.0	115	53	196	213	5 - 10	5 - 30	50	10	12
165.0	163.4 - 166.6	16.0	16.0	115	53	202	219	5 - 10	5 - 30	50	10	12
168.3	166.6 - 170.0	16.0	16.0	115	53	205	222	5 - 10	5 - 30	50	10	12

REFER TO MINIMUM WALL THICKNESS (see Technical Manual STRAUB)

- Follow fitting instructions
- According to DIN 86128
- PN () = working pressure considering the application loads
Test pressure = PN () x 1.5 (for example industry, water supply etc.)
- PN () = nominal pressure, includes four times safety factor (e.g. shipbuilding)
- The pressure values are valid on radial rigid carbon steel pipes under static loads
- Strip inserts are optional accessories (see Technical Manual STRAUB)
- Additional sealing sleeves and temperature ranges on request

STRAUB-GRIP-FIRE-FENCE | Ø 180.0 - 406.4 mm

Components / Materials	W1	W2	W4	W5
Casing		AISI 316 L or similar		AISI 316 L or similar
Bolts		AISI 4135		A4 - 80
Bars		AISI 12L14, galvanised		AISI 316 L or similar
Anchoring rings		AISI 301		AISI 301
Strip insert (option)		AISI 316 L or similar / HDPE		AISI 316 L or similar / HDPE
Sealing sleeve EPDM	Temp.: -20°C up to +100°C Medium: all qualities of water, waste water, air, solids and chemical products			
Sealing sleeve NBR	Temp.: -20°C up to +80°C Medium: water, gas, oil, fuel and other hydrocarbons			
Sealing sleeve FPM/FKM	Temp.: -20°C up to +180°C Medium: ozone, oxygen, acids, gas, oil and fuel (only with strip insert)			

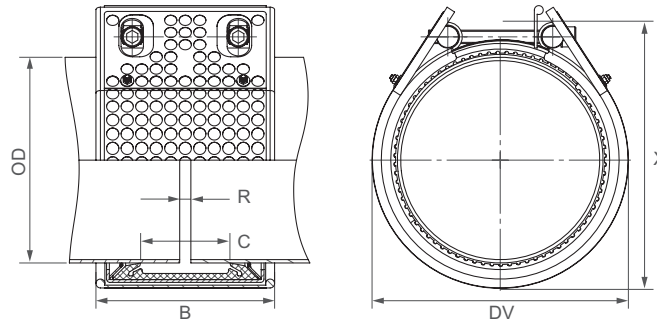

OD [mm]	Clamping range [mm]	PN [bar]	PN [bar]	B [mm]	C [mm]	DV [mm]	X [mm]	R without strip insert [mm]	R with strip insert [mm]	Torque rate [Nm]	Allen head [mm]	Thread M...
180.0	178.0 - 182.0	16.0	10.0	158	80	260	238	5 - 10	5 - 35	50	10	12
193.7	192.0 - 195.5	16.0	10.0	158	80	275	248	5 - 10	5 - 35	50	10	12
200.0	198.0 - 202.0	15.0	10.0	158	80	280	254	5 - 10	5 - 35	50	10	12
204.0	202.0 - 206.0	14.0	10.0	158	80	285	258	5 - 10	5 - 35	50	10	12
206.0	204.0 - 208.0	14.0	5.5	158	80	234	258	5 - 10	5 - 35	50	10	12
219.1	216.9 - 221.3	16.0	10.0	142	80	250	274	5 - 10	5 - 30	60	10	12
244.5	242.0 - 247.0	9.0	5.5	158	80	325	299	5 - 10	5 - 35	50	10	12
250.0	247.5 - 252.5	9.0	5.5	158	80	330	304	5 - 10	5 - 35	50	10	12
254.0	251.5 - 256.5	9.0	5.5	158	80	330	308	5 - 10	5 - 35	50	10	12
256.0	253.5 - 258.5	9.0	5.5	158	80	284	308	5 - 10	5 - 35	50	10	12
267.0	264.5 - 269.5	8.0	5.0	158	80	345	321	5 - 10	5 - 35	50	10	12
273.0	270.5 - 275.5	7.0	4.0	158	80	350	327	5 - 10	5 - 35	60	10	12
304.0	301.0 - 307.0	6.0	4.0	158	80	380	331	5 - 10	5 - 35	60	10	12
306.0	303.0 - 309.0	6.0	3.0	158	80	334	358	5 - 10	5 - 35	60	10	12
323.9	320.5 - 327.0	5.0	3.0	158	80	400	378	5 - 10	5 - 35	60	10	12
355.6	352.0 - 359.0	10.0	2.5	158	67	430	410	5 - 10	5 - 35	90	14	16
406.4	402.5 - 410.5	7.0	2.0	158	67	475	460	5 - 10	5 - 35	100	14	16

REFER TO MINIMUM WALL THICKNESS (see Technical Manual STRAUB)

Remarks:

- Follow fitting instructions
- PN (🏭) = working pressure considering the application loads
Test pressure = PN (🏭) x 1.5 (for example industry, water supply etc.)
PN (🚢) = nominal pressure, includes four times safety factor (e.g. shipbuilding)
- The pressure values are valid on radial rigid carbon steel pipes under static loads
- Strip inserts are optional accessories (see Technical Manual STRAUB)
- Additional sealing sleeves and temperature ranges on request