

## STRAUB-COMBI-GRIP | $\varnothing$ 40.0/38.0 - 355.0/355.6 mm

Components / Materials	W1	W2	W4	W5
Casing		AISI 316 L	AISI 316 L	AISI 316 L or similar
Bolts		AISI 4135	A4 - 80	A4 - 80
Bars		AISI 12L14, galvanised	AISI 304 / 316 L	AISI 316 L or similar
Anchoring rings		AISI A106, galvanised	AISI 304	AISI 301 / 304
Strip insert (option)		AISI 316 L or similar / PVDF	AISI 316 L or similar / PVDF	AISI 316 L or similar / PVDF
<b>Sealing sleeve EPDM</b>	Temp.: -20°C up to +100°C Medium: all qualities of water, waste water, air, solids and chemical products			
<b>Sealing sleeve NBR</b>	Temp.: -20°C up to +80°C Medium: water, gas, oil, fuel and other hydrocarbons			

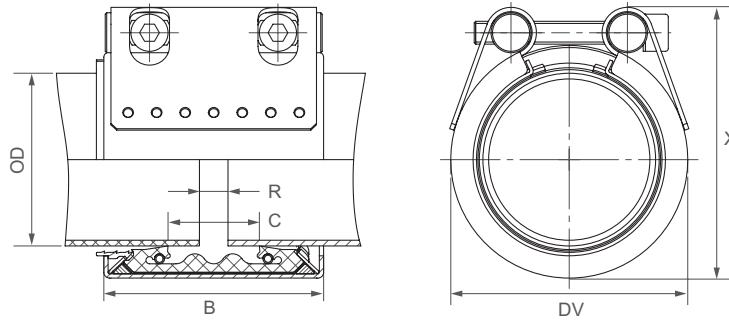

OD [mm]	Clamping range [mm]		PN [bar]	B [mm]	C [mm]	DV [mm]	X [mm]	R without strip insert [mm]	R with strip insert [mm]	Torque rate [Nm]	Allen head [mm]	Thread M...
	Plastic	Metal										
40.0/38.0	39.0 - 40.5	37.5 - 39.0	16.0	61	19	60	73	5	5 - 10	15	6	8
40.0/42.4	39.0 - 40.5	42.0 - 43.5	16.0	61	20	63	76	5	5 - 10	15	6	8
50.0/48.3	49.0 - 50.5	47.8 - 49.0	16.0	61	26	70	83	5	5 - 10	15	6	8
63.0/60.3	62.0 - 64.0	59.7 - 61.0	16.0	76	32	85	98	5 - 10	5 - 25	20	6	8
75.0/76.1	74.0 - 76.0	75.0 - 77.5	16.0	94	39	100	117	5 - 10	5 - 25	30	8	10
90.0/88.9	89.0 - 91.0	87.0 - 90.0	16.0	94	39	118	123	5 - 10	5 - 25	30	8	10
110.0/108.0	109.0 - 111.0	106.5 - 110.5	16.0	94	39	135	151	5 - 10	5 - 25	30	8	10
110.0/114.3	109.0 - 111.0	112.0 - 116.0	16.0	97	45	139	157	5 - 10	5 - 25	30	8	10
114.3/114.3	113.0 - 115.0	112.0 - 116.0	16.0	94	39	140	157	5 - 10	5 - 25	30	8	10
140.0/139.7	139.0 - 142.0	137.5 - 141.0	16.0	109	43	168	191	5 - 15	5 - 30	60	10	12
160.0/159.0	159.0 - 162.0	157.0 - 160.5	16.0/10.0*	109	43	188	210	5 - 15	5 - 30	60	10	12
160.0/168.3 <sup>1</sup>	159.0 - 162.0	166.6 - 170.0	16.0	110	54	192	222	5 - 10	5 - 30	20	10	12
200.0/206.0	198.0 - 202.0	204.0 - 208.0	16.0	141	80	227	246	5 - 15	5 - 35	60	10	12
225.0/219.1	223.0 - 227.0	216.9 - 221.3	10.0	141	80	252	271	5 - 15	5 - 35	60	10	12
225.0/229.0	223.0 - 227.0	227.0 - 231.0	10.0	141	80	252	271	5 - 15	5 - 35	60	10	12
250.0/256.0	248.0 - 252.0	253.5 - 258.5	10.0	141	80	277	296	5 - 15	5 - 35	60	10	12
315.0/323.9	313.0 - 317.0	320.5 - 327.0	10.0	141	80	342	365	5 - 15	5 - 35	120	14	16
355.0/355.6	353.0 - 357.0	352.0 - 359.0	6.0	141	80	382	405	5 - 15	5 - 35	150	14	16

### Remarks:

- Follow fitting instructions
- PN = working pressure considering the application loads  
Test pressure = PN x 1.5 (for example industry, water supply etc.)
- For the installation of pipes of pipes made of HDPE and PP, STRAUB stiffening rings are required (see page 29)
- Strip inserts are optional accessories (see Technical Manual STRAUB)
- Additional sealing sleeves and temperature ranges on request

\* 160.0/159.0 mm: version in W2  $\Rightarrow$  PN 16 bar  
version in W4  $\Rightarrow$  PN 10 bar  
160.0/168.3 mm: only available in W5

## STIFFENING RINGS

Thermoplastic pipes can be deformed under the influence of pressure and heat.

Through the use of STRAUB stiffening rings, a constriction of the plastic pipe ends is prevented.

STRAUB stiffening rings consist of stainless steel DIN 1.4301/AISI 304 and are available in slotted (OD 40 - 315mm) and welded designs (OD 355 - 1600 mm). One of the following may be required:

- Inside diameter
- SDR number
- Wall thickness of the plastic pipe

If the pipes already exhibit constriction due to long storage, we recommend cutting off these constricted sections before fitting the STRAUB stiffening rings. Slotted stiffening rings must be fitted in the direction of the arrow marked and installed flush with the pipe end.

### Note:

For plastic pipes in PVC, ABS and CPVC, and with fibreglass pipes, no stiffening rings are required for media temperatures under 40°C.

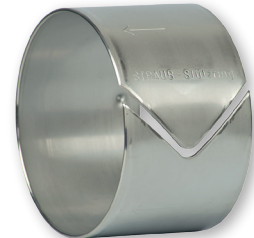

Table for choosing the STRAUB-PLAST-GRIP stiffening ring

SDR	41	33	26	17	11	7.4
Serie-Nr.	S 20	S 16	S 12.5	S 8	S 5	S 3.2
Norm	DIN 8074	DIN 8074	DIN 8074	DIN 8074	DIN 8074	DIN 8074
Pipe OD	Pipe ID	Pipe ID	Pipe ID	Pipe ID	Pipe ID	Pipe ID
OD [mm]	[mm]	[mm]	[mm]	[mm]	[mm]	[mm]
40	-	-	36.4	35.2	32.6	29
50	-	46.4	46.0	44.0	40.8	36.2
63	59.4	59.0	58.0	55.4	51.4	45.8
75	71.2	70.4	69.2	66.0	61.4	54.4
90	85.6	84.4	83.0	79.2	73.6	65.4
110	104.6	103.2	101.6	96.8	90.0	79.8
125	118.8	117.2	115.4	110.2	102.2	90.8
140	133.0	131.4	129.2	123.4	114.6	101.6
160	152.0	150.2	147.6	141.0	130.8	116.2
180	171.2	169.0	166.2	158.6	147.2	130.8
200	190.2	187.6	184.6	176.2	163.6	145.2
225	214.0	211.2	207.8	198.2	184.0	163.4
250	237.6	234.6	230.8	220.4	204.6	181.6
280	266.2	262.8	258.6	246.8	229.2	203.4
315	299.6	295.6	290.8	277.6	257.8	228.8

### Remarks:

- Choosing stiffening rings owing to measurements on pipes only conditionally possible
- Valid only to soft thermoplastic pipes f.e. PE, PP, etc.
- Stiffening rings are optional accessories and has to be ordered separately.