

Floating Skimmer System

PROTEGO® SA/DA

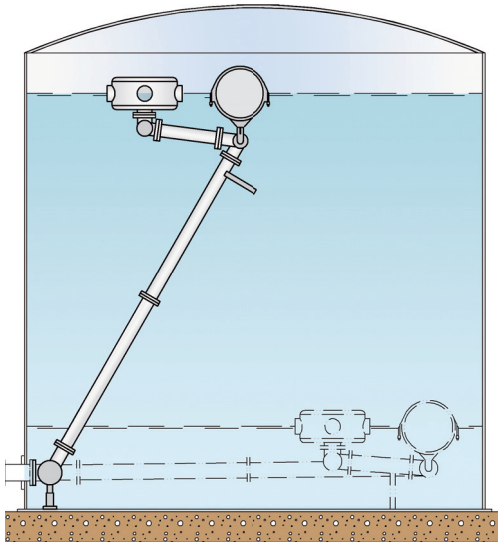

PROTEGO® SA/DA for fixed roof tanks

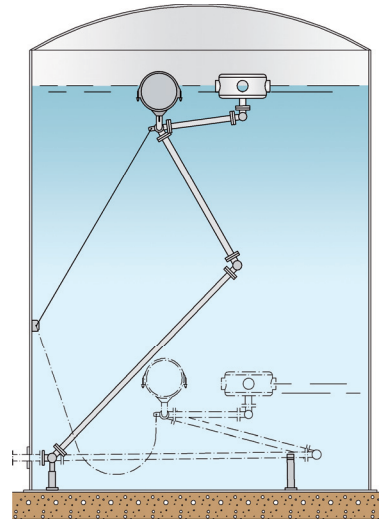

PROTEGO® SA/DA with double-bend for fixed roof tanks

Function and Description

Fixed roof tanks that store liquids with different density these so-called slop tanks are fitted with the Floating Skimmer System PROTEGO® SA/DA for separating the phases. The design of the skimmer results from different densities. They are developed to draw off the product with lower specific weight from the surface of the stored medium.

Design Types and Specifications

PROTEGO® SA/DA Floating Skimmer Systems are designed and sized to suit the individual tank specifications and the stored medium as well as customer requirements.

PROTEGO® SA/DA Floating Skimmer Systems are designed for a long life in service in complete medium contact.

We use carbon steel or stainless steel for highly loaded components or aggressive media.

Solutions are available from 2" to 6" for tanks with fixed roofs.

Selection and Design

PROTEGO® Floating Skimmer Systems offer experienced technology for a complete solution for the end-user. This includes easy installation and assembly of the system in the tank and full documentation with an arrangement drawing showing the Floating Skimmer System placed in the tank with regards to all internals.

Essential for the design of the PROTEGO® Floating Skimmer Systems is the Heavy Duty Swivel Joint which fulfils the requirement for an in-service installation to avoid high costs of repairs and to extend the tank maintenance to the planned interval.

The Swivel Joint comes with/in

- a sturdy design made of carbon or stainless steel
- maintenance-free greased for a life-time with aviation approved grease
- large sized ball bearings with two races to cover all side-flow forces during operation.

PROTEGO® Floating Skimmer Systems SA/DA are fitted with a separate skimming float that is just responsible for separating the different phases. The weight of the complete system is floated by one or more floats.

Floats are always made of stainless steel and are 100 % pressure tested.

PROTEGO® Floating Skimmer Systems are „Made in Germany“ and will provide many years of trouble free tank operation.

*Project:
Location:
Client:
*Enduser:
*Engineering:

Tank Main Details

*Fixed roof tank	<input type="checkbox"/>		
Tank No.:	*Tank height: :	mm	*Tank diameter: mm
*Maximum filling height:	mm		
*Material request of Skimming Systems:			

Product Details

*Stored liquid:	Specific gravity:
*Sucked in liquid:	Specific gravity:
Maximum product temperature: °C	

Tank Details

*Skimming System size: DN			
*Shell nozzle centreline height / inwards projection	mm		
*Manhole size: DN			
Bottom slope: <input type="checkbox"/>	Slope direction:		
*Are there any obstructions? (columns, heating coils,...)	<input type="checkbox"/>	if <input checked="" type="checkbox"/> - please specify	
*Tank drawing / sketch	<input type="checkbox"/>	if <input checked="" type="checkbox"/> - specify request	

* This information must be indicated on request!
Fill in and tick off, if applicable.