

PROTEGO® Catalogue 2018 / 2019

Excellence in Safety and Environment

For more product information please visit our website:
www.protego.com



PROTEGO

for safety and environment

Protecting life - preserving value. For over 60 years.

Welcome to Braunschweiger Flammenfilter GmbH. In your hand, you are holding the most recent edition of our catalogue.

Braunschweiger Flammenfilter GmbH is a medium sized company with over 400 co-workers in multiple locations worldwide. With 12 subsidiaries we are present on all continents. Under the brand name PROTEGO®, we manufacture a wide range of safety devices and tank accessories where as a market leader we have specialized in this field.

We are ready to advise our customers worldwide with products you can trust whether for process engineering applications, chemicals production, pharmaceutical, petroleum or the biogas industry.

For over 60 years, Braunschweiger Flammenfilter GmbH is known for its efficient know-how in developing safety devices particularly for the production, storage and transport of flammable liquids and gases.

Our customers find that we achieve top-level performance of:

- Problem solving
- Quality
- Consulting/Advising
- Environmental preservation

Together with our subsidiaries and sales partners such as PROTEGO® Authorized Repair Centers (PARC) we accomplish this mission globally.

As a medium sized family owned business we have maintained power and flexibility and are financially independent of our partners. We are proud of our highly qualified and motivated staff with whom we continuously evolve and develop into the future.

Illuminate yourself with an oversight of our competence and perspective of teamwork at Braunschweiger Flammenfilter GmbH.

Our Vision & Mission

Thinking sustainably - taken by enthusiasm

PROTEGO® Vision: Excellence in Safety and Environment.

PROTEGO® Mission: A profitable, independent, international family business that, while developing and manufacturing safety valves and equipment, is the top-notch competence source for technology, quality, availability, services, engineering, and consultancy.

Our fields of activities are explosion protection as well as environmental conservation through retaining and relieving pressure in the exploration, processing and storage of flammable liquids and gases.



Type	Designation	Chapter	Type	Designation	Chapter
AL 200	Vent valve	8	LDA-WF(W)	Detonation flame arrester	4
AL/DK	Vent valve	8	LH/AD	Deflagration flame arrester	2
BE/AD	Deflagration flame arrester	2	LH/AD-T	Deflagration flame arrester	2
BE/HK	Deflagration flame arrester	protego.com	LH/EB	Deflagration flame arrester	protego.com
BE/HK-E	Deflagration flame arrester	2	NB/AP	In-Tank Valve	9
BE/HR	Deflagration flame arrester	protego.com	P/EB	Pressure relief valve	7
BE/HR 400	Deflagration flame arrester	2	P/EB-E	Pressure relief valve	7
BE/HR-D	Pressure relief valve	7	P/EBR	Pressure relief valve	7
BE/HR-E	Deflagration flame arrester	2	P/EBR-E	Pressure relief valve	7
BR/TS	Detonation flame arrester	protego.com	P/EL	Pressure relief valve	5
D/KSM	Pressure relief valve	5	P/ELR	Pressure relief valve	5
D/SVL	Pressure relief valve	5	PU-IIA	Gauging pipe	protego.com
D-SVL-EB	Pressure relief valve	7	PF/K	Gauge hatch with flange	8
DA-CG	Detonation flame arrester	4	PF/TK	Gauge hatch with flange	8
DA-E	Detonation flame arrester	4	PG/H	Sampling pot	protego.com
DA-G	Detonation flame arrester	4	PS/K	Gauge hatch with welded nozzle	8
DA-SB	Detonation flame arrester	4	PS/KF	Gauge hatch with flange	8
DA-SB-PTFE	Detonation flame arrester	protego.com	PS/TK	Gauge hatch with welded nozzle	8
DA-UB	Detonation flame arrester	4	PM(D)S	Pressure/Vacuum relief valve	9
DA-UCG	Detonation flame arrester	protego.com	PM-HF	Pressure/Vacuum relief valve	9
DE/S	Pressure relief valve	protego.com	PR/0	Gauging and sampling pipe	protego.com
DE/S-MK VI	Pressure relief valve	protego.com	PS/E	Gauging nozzle	protego.com
DR/ES	Detonation flame arrester	4	PV/EB	Pressure/Vacuum relief valve	7
DR/ES-PTFE	Detonation flame arrester	protego.com	PV/EB-E	Pressure/Vacuum relief valve	7
DR/ES-V	Detonation flame arrester	4	PV/EBR	Pressure/Vacuum relief valve	7
DR/EU	Detonation flame arrester	4	PV/EBR-E	Pressure/Vacuum relief valve	7
DR/SBW	Detonation flame arrester	protego.com	PV/EL	Pressure/Vacuum relief valve	5
DR/SV	Detonation flame arrester	protego.com	PV/ELR	Pressure/Vacuum relief valve	5
D/SR	Roof drain valve	8	R/KSM	Pressure/Vacuum relief valve	6
D/SR-W	Roof drain valve	8	SA/DA	Floating skimmer system	8
DV/ZT	Pressure/Vacuum relief valve	6	SA/S	Floating suction unit	8
DV/ZT-F	Pressure/Vacuum relief valve	6	SD/BS-H	Pressure relief valve	5
DV/ZU	Pressure/Vacuum relief valve	6	SE/CK	Floating roof drainage system with swivel joints	8
DV/ZU-F	Pressure/Vacuum relief valve	6	SE/K	Floating roof drainage system with metal hose joint	8
DV/ZW	Pressure/Vacuum relief valve	6	SI/DP	In-Tank Valve	9
DV/ZW-F	Pressure/Vacuum relief valve	6	SI/F	Internal safety valve	8
DZ/E	Pressure/Vacuum relief valve	6	SV/E	Vacuum relief valve	7
DZ/EA	Pressure/Vacuum relief valve	6	SV/E-1-0	Vacuum relief valve	5
DZ/EA-F	Pressure/Vacuum relief valve	6	SV/T-0-H	Vacuum relief valve	5
DZ/E-F	Pressure/Vacuum relief valve	6	TS/E, TS-P, TS/W	Detonation flame arrester	4
DZ/T	Pressure/Vacuum relief valve	6	UB/DF	Pressure/Vacuum relief valve	7
DZ/T-F	Pressure/Vacuum relief valve	6	UB/SF	Pressure/Vacuum relief valve	7
E/KS	Vent cap	protego.com	UB/VF	Pressure/Vacuum relief valve	7
EB	Vent cap	2	V/KSM	Vacuum relief valve	5
EB-Z	Vent cap	protego.com	V/SV	Vacuum relief valve	protego.com
EF/V	Detonation flame arrester	4	V/SV-XL	Vacuum relief valve	9
EH/0	Vent cap	protego.com	V/SV-XXL	Vacuum relief valve	9
EH/OS	Vent cap	protego.com	VD/KSM	Pressure/Vacuum relief valve	5
ER/V	Pressure relief valve	protego.com	VD/KSM-PA	Pressure/Vacuum relief valve	5
ER-V-LP	Pressure relief valve	5	VD/SV	Pressure/Vacuum relief valve	5
ER/V-F	Pressure relief valve	5	VD/SV-AD(L)	Pressure/Vacuum relief valve	7
ER/VH	Pressure relief valve	5	VD-SV-EB	Pressure/Vacuum relief valve	7
FA-CN	Deflagration flame arrester	3	VD/SV-HR	Pressure/Vacuum relief valve	7
FA-E	Deflagration flame arrester	3	VD/SV-HRL	Pressure/Vacuum relief valve	7
FA-G	Deflagration flame arrester	3	VD/SV-PA(L)	Pressure/Vacuum relief valve	5
FA-I ATEX	Deflagration flame arrester	3	VD/TS	Pressure/Vacuum relief valve	7
FA-I-PTFE	Deflagration flame arrester	protego.com	VN-A-PC	Pressure/Vacuum relief valve	protego.com
ITV-S	In-Tank Valve	protego.com	VP/HK	Gauging and sampling device	8
LA	Air-drying device	protego.com	WV/T	Change-over valve	9
LA-V	Air-drying device with with check valve	protego.com	ZE/TK	Condensate drain valve	8
LDA	Detonation flame arrester	4	ZE/WU	Sampling and air bleed valve	8
LDA-F	Detonation flame arrester	4	ZM-R	Blanketing valve	6
LDA-W	Detonation flame arrester	4			

Information at a glance

Product diversity

Tailored devices are our day-to-day business.

In this catalogue, you will find a selection from our extensive range of products. We also supply devices which require **special approvals due to** special operating conditions, such as exceptionally high **temperatures and pressures**, or for **specific applications**. Just contact our friendly sales team.



New additions to our catalogue

New products are marked with the symbol shown on the right.

NEW

QR codes in the catalogue

Scan the QR code for speedy access to additional information online.



protego.com

If you see this symbol, check out our homepage for more information.



PROTEGO® QuEST

Quick Engineering & Sizing Tool

PROTEGO® QuEST is the software for sizing and selection of our venting devices.



PROTEGO® Engineering Service

PROTEGO® Engineering Service is the new engineering consulting branch within the PROTEGO® Group. We assist our customers with detailed tank modeling and safety analyses beyond the sphere of PROTEGO® device application.



PARCs

PROTEGO® Authorized Repair Center: PARCs offer skilled regional support to meet your repair and maintenance needs.



Contact details

If you have any questions or special requests, our friendly and capable sales team will be happy to advise you.





PROTEGO® Technology..... Volume 1

Flame Arresters

Deflagration Flame Arresters, end-of-line and Vent Caps..... Volume 2

Deflagration Flame Arresters..... Volume 3

Detonation Flame Arresters..... Volume 4

Valves

Pressure and Vacuum Relief Valves, end-of-line..... Volume 5

Pressure and Vacuum Relief Valves, in-line..... Volume 6

Pressure and Vacuum Relief Valves with Flame Arresters, end-of-line..... Volume 7

Tank Accessories and Special Equipment..... Volume 8

Equipment for Cryogenic Tanks..... Volume 9

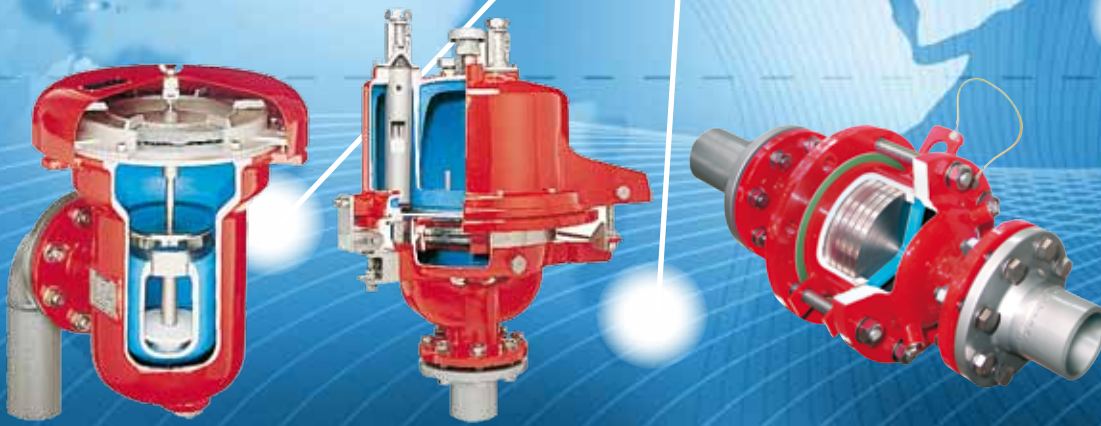

Volume 1

- **Flame Arresters**
- **Valves**
- **Tank Accessories**



for safety and environment

How to use this catalogue

The PROTEGO® catalogue has a modular structure.

In Volume 1 the company is introduced and with the “Technical Fundamentals” and the “Safe Systems in Practice” a basic explanation of operation and use of PROTEGO® devices is provided.

In the following Volumes 2 through 9 the devices are described in detail.



Typical Applications

- Storage Tanks and Loading Facilities
- Vapour-return at Petrol Stations
- Combustion Systems
- Chemical and Pharmaceutical Processing Systems
- Landfill and Biogas Systems
- Wastewater Treatment Systems

Exotic Applications

- Nitrous Oxide Supply in Clinical Applications
- Explosionproof Surface Drain at Heliports
- Storage of Whisky Barrels
- Production of Brandy

Special Applications

- Food Sterilization under Vacuum
- Wafer Production in IT Industry
- Methane Extraction Fan of Mines
- Vitamine Production
- Production of Tooth Paste and Mouthwash

PROTEGO® – about us	12
Technical Fundamentals	14
Flame Arresters.....	14
Pressure and Vacuum Relief Valves.....	19
Pressure and Vacuum Relief Valves with Flame Arresters.....	24
Venting Requirements of Aboveground Storage Tanks - Sizing and Calculation Formulas.....	26
Safe Systems in Practice	34
Storage Tanks in Tank Farms for Refineries and Chemical Processing Plants.....	35
Chemical and Pharmaceutical Processing Facilities.....	36
Vapour Combustion Systems and Flares.....	37
Ship Building and Loading Systems.....	38
Biogas Systems, Wastewater Treatment, and Landfill Gas Systems.....	39
Flame Arresters as integrated Equipment Components.....	40
Cryogenic Tanks.....	41
Overview of Products and Services	42
Deflagration Flame Arresters, end-of-line and Vent Caps.....	42
Deflagration Flame Arresters.....	42
Detonation Flame Arresters.....	42
Equipment for Cryogenic Storage Tanks.....	42
Pressure and Vacuum Relief Valves, end-of-line.....	43
Pressure and Vacuum Relief Valves, in-line.....	43
Pressure and Vacuum Relief Valves with Flame Arrester, end-of-line.....	43
Tank Accessories and Special Equipment.....	43
Appendix	44
Regulations, Laws, Standards and PROTEGO® Publications.....	44
Glossary.....	46
Materials, Units and Conversion Factors.....	56
Data Sheet for PROTEGO® Devices.....	57





Corporate Video

Our Vision & Mission

Thinking sustainably - taken by enthusiasm

PROTEGO® Vision: Excellence in Safety and Environment.

PROTEGO® Mission: A profitable, independent, international family business that, while developing and manufacturing safety valves and equipment, is the top-notch competence source for technology, quality, availability, services, engineering, and consultancy. Our fields of activities are explosion protection as well as environmental conservation through retaining and relieving pressure in the exploration, processing and storage of flammable liquids and gases.

PROTEGO® World Team

Providing first-class performance

- Dedicated to solutions
- High-quality standard
- Consultative
- Environmentally compatible

PROTEGO® is a world market leader operating with a large global network of subsidiaries and representations. The PROTEGO® Team includes 12 distribution and after-sales service companies as well as 120 representations in all continents.





Competences



Maintenance & Service



Contact

Competence is Top Priority

What can you expect from us? The full range.

PARC'S: PROTEGO® Authorized Repair Centers (PARCs) assist with maintenance on site. The PARCs, being certified service partners, meet the requirements of the PROTEGO® Works Standard in the fields of human resources, organization, workshop equipment, machinery, as well as quality and environmental management.

Spare Parts Service: All our centers hold in stock genuine spare parts for you. Genuine parts and periodical maintenance, geared to the particular field service conditions, guarantee trouble-free operation.

Consultancy: Experienced PROTEGO® experts are available to assist with the varied and subtly differentiated application issues. They have been trained to consider engineering tasks from a process safety perspective.

Maintenance: We can place at your disposal our field staff for installation and maintenance which have been adequately trained and prepared for their tasks at the manufacturer's; alternatively, you may just resort to our authorized workshops.



In the Company's worldwide largest Research & Development Center

We develop - highly committed and successfully

In developing our products we closely cooperate with users, technical institutes and notified bodies. To this end, the PROTEGO® Research & Development Center - worldwide the largest of its kind - does not only serve to improve and upgrade our products; it is also available for general research projects and tailor-made dedicated development work. The potential offered includes investigations and testing with nominal sizes up to DN 1000 / 40" as well as higher pressures, temperatures and oxygen enrichment.

National and international notified bodies satisfying themselves periodically of the high standard seek our support too.





Development

Flame arresters protect systems subject to explosion hazards from the effects of explosions. Ever since methane gas explosions were successfully suppressed in the mining industry in the mid-19th century by the development of the mine shaft lamp with a Davy screen, solutions have been found for making systems safer in modern hydrocarbon chemistry, where much more hazardous gases are used.

In addition, filling stations became necessary with the introduction of the automobile. With filling station tanks, the problem of explosive vapours arose, consisting of hydrocarbons and air that form around the tanks and loading equipment, which can ignite. Given the need for safe handling in dangerous atmospheres, the large oil companies advanced the development of protective devices for both industrial and military applications.

Initial successes were achieved with gravel pots that were used on fuel tanks. The entrance of an explosion in the atmosphere into the storage tank or into the connected line was stopped by the gravel, and the flame was extinguished. The tank remained protected. The problem with loose gravel, however, is the not reproducible flame arresting capability and the high pressure losses. In 1929, a new development was patented that replaced the loose gravel with wound corrugated strips of metal (Fig. 1a). Together with the patented shock-absorber, a protective device was developed that stopped detonative combustion processes in the pipe at minimum pressure loss. The PROTEGO® detonation flame arrester – developed by Robert Leinemann – was born (Fig. 1b). It was given its name many years later in 1954 when Robert Leinemann founded his company Braunschweiger Flammenfilter.

As chemical processes developed, the requirements on protective devices became increasingly complex. To this the requirements of environmental protection were added. Vapours from processes needed to be disposed in an environmentally friendly manner and supplied to combustion systems according to clean-air regulations. The continuously or only occasionally explosive mixture was sent to an ignition source during operation. These particular hazards had to be countered with special measures. PROTEGO® flame arresters offer reliable protection in plant systems; these flame arresters always correspond to the state-of-the-art as a result of continuous research and development.

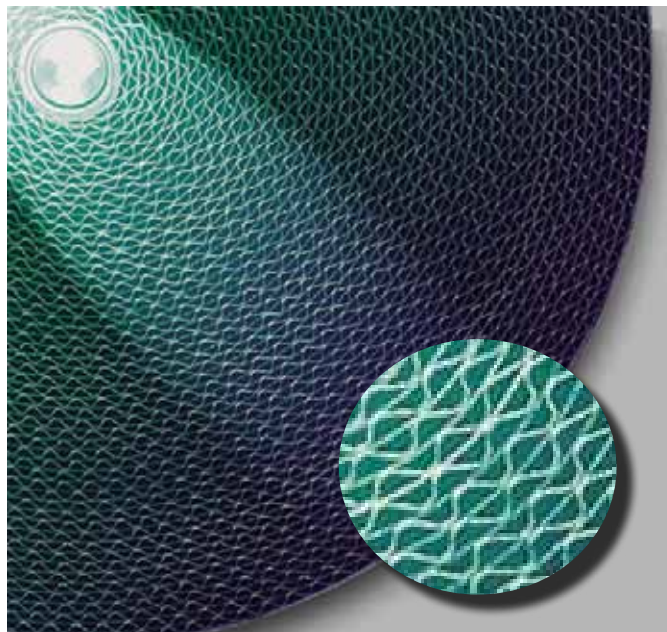

Figure 1a: FLAMEFILTER® wound out of corrugated metal strips

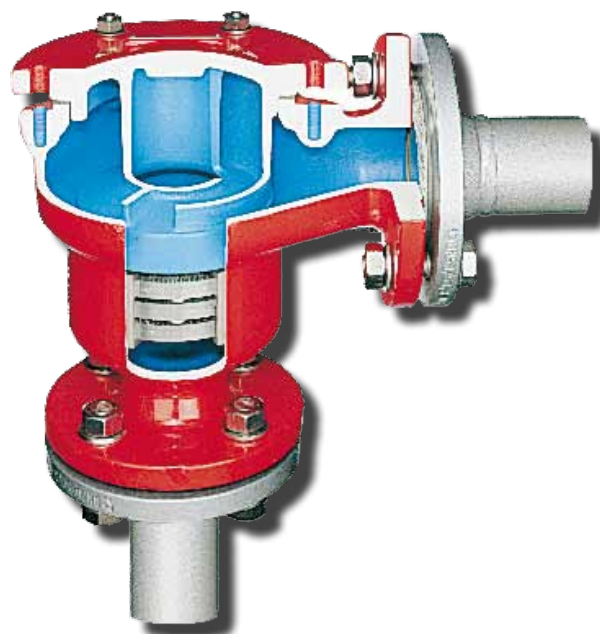

Figure 1b: Detonation Flame Arrester with Shock-Absorber

Combustion Processes

Explosive mixtures can burn in various ways. The following, among other things, can influence the combustion process: the chemical composition of the mixture, possible pressure waves, pre-compression, the geometric shape of the combustion chamber, and the flame propagation speed.

The relevant **combustion processes** for flame arresters are defined by international standards:

Explosion is the generic term for abrupt oxidation or decomposition reaction producing an increase in temperature, pressure or both simultaneously [also see EN 1127-1].

Deflagration is an explosion that propagates at subsonic velocity [EN 1127-1]. Depending on the geometric shape of the combustion area, a distinction is drawn between atmospheric deflagration, pre-volume deflagration and in-line deflagration.

Atmospheric deflagration (Fig. 2) is an explosion that occurs in open air without a noticeable increase in pressure.

Pre-volume deflagration (Fig. 3) is an explosion in a confined volume (such as within a vessel) initiated by an internal ignition source.

In-line deflagration (Fig. 5) is an accelerated explosion within a pipe that moves along the axis of the pipe at the flame propagation speed.

Stabilized burning is the even, steady burning of a flame, stabilized at or close to the flame arrester element. A distinction is drawn between **short time burning** (stabilized burning for a specific period) and **endurance burning** (stabilized burning for an unlimited period) (Fig. 4).

Detonation is an explosion propagating at supersonic velocity and is characterised by a shock wave [EN 1127-1]. A distinction is drawn between **stable detonations** and **unstable detonations** (Fig. 5).

A detonation is **stable** when it progresses through a confined system without a significant variation of velocity and pressure characteristic (for atmospheric conditions, test mixtures and test procedures typical velocities are between 1,600 and 2,200 meter/second). A detonation is **unstable** during the transition of the combustion process from a deflagration into a stable detonation. The transition occurs in a spatially limited area in which the velocity of the combustion wave is not constant and where the explosion pressure is significantly higher than in a stable detonation. NOTE: The position of this transition zone depends, among others, on the operating pressure and operating temperature, on the pipe diameter, the pipe configuration, the test gas and the explosion group and must be predetermined by experiments in each case.

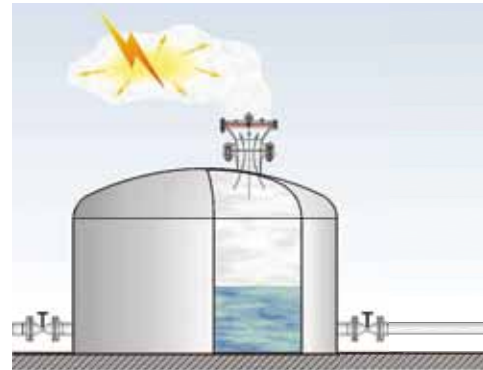

Figure 2: Atmospheric deflagration

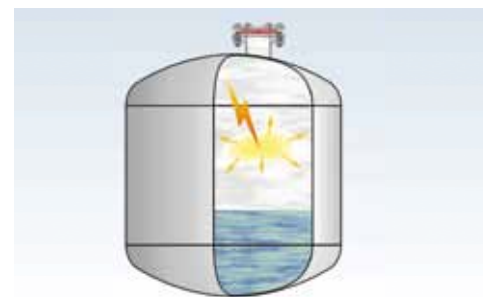

Figure 3: Pre-volume deflagration

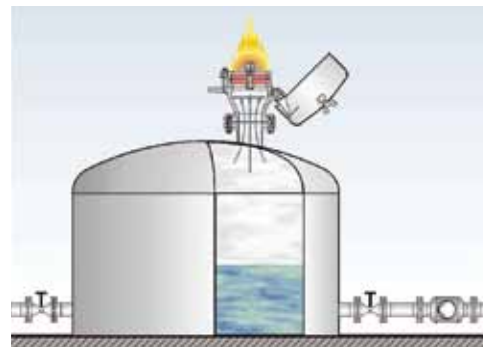

Figure 4: Stabilized burning

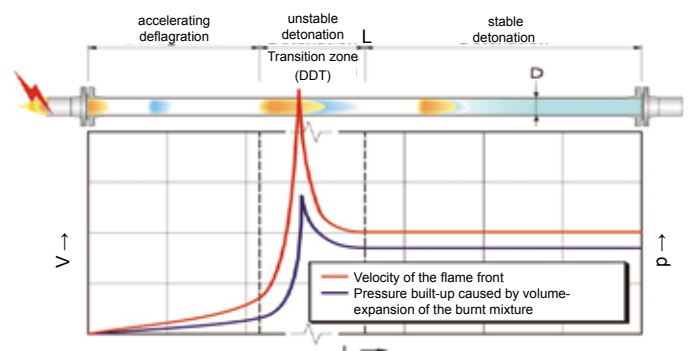

Figure 5: Deflagration – unstable detonation – stable detonation.

L = distance to ignition-source

D = Diameter of the pipeline

v = velocity of the flame front

p = pressure

DDT = Deflagration to Detonation Transition



for safety and environment

Master Types

Flame arresters are subdivided into different types depending upon the combustion process (Endurance burning, Deflagration, Detonation and the various sub-groups) and in accordance to the installation (in-line, end-of-line, in equipment).

Master types are

- static dry flame arresters
- static liquid seal flame arresters
- dynamic flame arresters

Working principle

a) Static dry flame arresters

Flame arrester elements made of wound corrugated metal strips can be manufactured with consistently reproducible flame quenching gaps. The gap-size can be adjusted in accordance to the flash-back capability of the explosive mixture.

The FLAMEFILTER® is made of wound corrugated metal strips and forms the flame arrester element. The principle of flame quenching in small gaps is applied in PROTEGO® end-of-line flame arresters and PROTEGO® in-line flame arresters (volume 2, 3, 4 and 7).

When a mixture ignites in a gap between two walls, the flame spreads towards the non-combusted mixture. The expansion in volume of the combusted mixture pre-compresses the non-combusted mixture and accelerates the flame.

By heat dissipation in the boundary layer “s”, transferring it to the large surface of the gap-length compared to the gap-width “D” and cooling-down the product below its ignition temperature (Fig. 6) the flame is extinguished.

The gap width and the gap length of the flame arrester element determines its extinguishing ability.

The narrower and longer the gap, the greater the extinguishing effectiveness. The wider and shorter the gap, the lower the pressure loss. The optimum solution between the two conditions is determined by experiments.

Original PROTEGO® technology

To protect against all of the previously mentioned combustion processes, PROTEGO® developed static dry flame arresters and optimized their design and had them undergo national and international certifications in prototype tests (Fig. 7a and b).

All static dry PROTEGO® flame arresters are based on the working principle of FLAMEFILTER®.

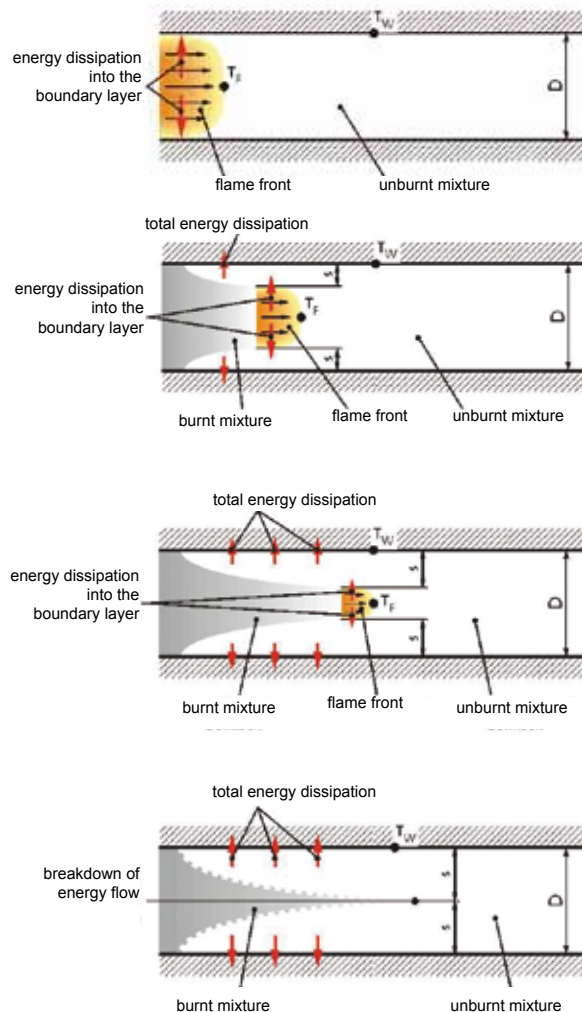
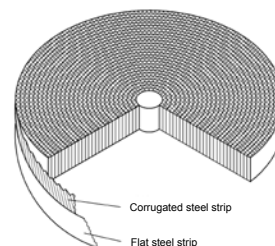

Figure 6: Extinguishing the flame in the narrow gap (flame quenching) by heat transfer

7a



7b

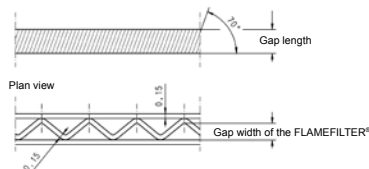
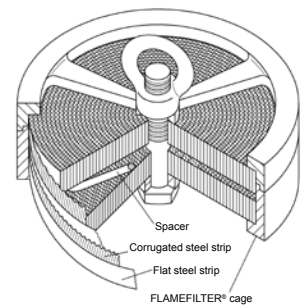

Figure 7: FLAMEFILTER® (a) with gap widths and gap lengths and PROTEGO® flame arrester unit (b) with FLAMEFILTER®, spacer and FLAMEFILTER® cage

Definitions

1. **Flame arresters** (Fig. 8a) are devices that are installed at the opening of an enclosure or to the connecting pipe of a system of enclosures and whose intended function is to allow flow but prevent the transmission of flame.

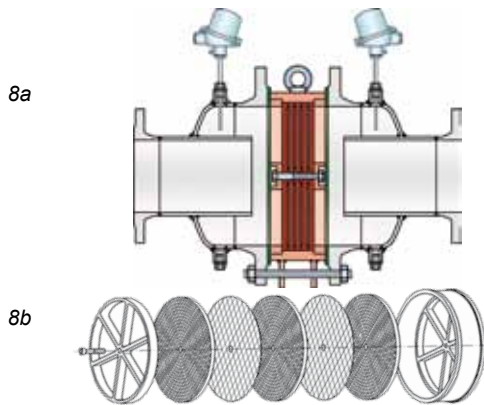

Figure 8: PROTEGO® flame arrester (a) and PROTEGO® flame arrester unit (b - modular design)

2. The PROTEGO® **flame arrester unit** (Fig. 8b and 7b) is that part of a flame arrester whose main task is to prevent the transmission of flames.
3. Several **FLAMEFILTER®** (Fig. 7a) form the PROTEGO® **flame arrester unit** (Fig. 7b and 8b) together with the spacers and enclosing cage.
4. Deflagration flame arresters or detonation flame arresters are required depending on installation and operating conditions. Depending on the mode of operation, resistance against stabilized burning (short burning, endurance burning) may be necessary.

b) Liquid seal flame arrester

In liquid seal flame arresters liquid barriers stop the entering deflagration and/or detonation before it reaches the protected components. Two different types exist.

1. The liquid product flame arrester: the liquid product is used to form a liquid seal as a barrier for flame transmission. The PROTEGO® liquid product flame arrester is an in-line or end-of-line detonation flame arrester (Vol. 4).
2. The hydraulic flame arrester: it is designed to break the flow of an explosive mixture into discrete bubbles flowing through water which acts like a liquid barrier. The PROTEGO® hydraulic flame arrester is designed and certified to stop deflagrations, detonations and endurance burning combustions. It is tailor-made with regard to the specific customers requirements (Vol. 4).

When installing the PROTEGO® hydraulic flame arrester as in-line flame arrester, as vent header collection drum and back flow preventer in vapour collecting lines close to the incinerator, important safety measures have to be taken into consideration to assure the required explosion safety.

c) Dynamic flame arresters

High velocity flame arresters are designed to produce flow velocities under operating conditions which exceed the flame velocity of the explosive mixture thus preventing flame transmission. This principle is applied in PROTEGO® Pressure Relief Diaphragm Valves (Vol. 7) and in PROTEGO® High Velocity Valves (Vol. 7) with appropriate high set pressure.

Flame arresters are type-examined **Protective Systems** in accordance with ATEX directive and are marked with CE. They are tested according to EN ISO 16852. They are certified in accordance with the specific requirements of the standard. Any certification according to other international standards is shown by marking with the appropriate indication.

Explosion groups

Different gases have different flame propagation capacities and are therefore categorized into explosion groups corresponding to their hazard level. The yardstick for this is the **MESG** = **Maximum Experimental Safe Gap**, a characteristic number measured in the laboratory for the flame propagation ability of the product. The MESG or **standard gap width** is the largest gap width between the two parts of the interior chamber of a test setup which, when the internal gas mixture is ignited and under specified conditions, prevents ignition of the external gas mixture through a 25 mm long gap, for all concentrations of the tested gas or vapour in air. The MESG is a property of the respective gas mixture [EN 1127-1]. NOTE: The test setup and methods are specified in EN 60079-20-1. The most explosive composition is close to the stoichiometric mixture of the gas/vapour-air mixture.

Explosion group	Max. Experimental Safe Gap (mm)	NEC	Reference Substances for testing flame arrester
IIA1*	≥ 1,14		Methane
IIA	> 0,90	D	Propane
IIB1	≥ 0,85	C	Ethene
IIB2	≥ 0,75	C	Ethene
IIB3	≥ 0,65	C	Ethene
IIB	≥ 0,5	B	Hydrogen
IIC	< 0,5	B	Hydrogen

* former designation Expl. Gr. I

The following table shows the categorization of substances into the respective explosion group corresponding to their MESG (IEC 79-1, EN ISO 16852).



Technical Fundamentals

Flame Arresters

Please refer to more specific literature (especially technical information concerning safety ratings) for the MESH of individual substances, additional ratings and characteristic substance quantities. This information is provided by PROTEGO® upon special request.

As the pressure and temperature increase, the load on the flame arresters generally increases. Flame arresters that have been tested under standard conditions are approved and can be used up to 60°C (140°F) and 1.1 bar (15.9 psi). If the operating temperature and/or the operating pressure is higher, the flame arrester must undergo a special examination for the higher operating parameters.

PROTEGO® offers flame arresters for the above mentioned explosion groups for higher pressures (>1.1bar abs, 15.9 psi) and higher temperatures (>60°C, 140°F) as required by the operating pressure or temperature.

Location of installation

Depending on the location of installation, the flame arresters must fulfill various protective tasks:

At the opening of a system part to the atmosphere

→ **End-of-line flame arrester**

At the opening of an equipment onto a connecting pipe

→ **Pre-volume flame arrester**

In the pipe

→ **In-line flame arrester**

PROTEGO® End-of-line flame arresters protect against atmospheric deflagrations and stabilised burning — either short time burning or endurance burning. They can only be connected on one side and can not be installed in the pipe. PROTEGO® end-of-line flame arresters can however be combined with val-

ves (see Volume 7: Pressure and Vacuum Relief Valves with PROTEGO® flame arresters).

PROTEGO® Pre-volume flame arresters are flame arresters which avoid flame transmission from the inside of an explosion-proof vessel to the outside or to a connected pipe.

PROTEGO® In-line flame arresters protect against deflagration, stable or unstable detonations in pipes. Stable detonation flame arresters avoid an explosion transmission of deflagrations and stable detonations. In-line flame arresters which are tested against unstable detonations protect from deflagrations, stable and unstable detonations.

The flame arresters should be located according to their specified use. In the case of in-line deflagration flame arresters, make sure that the allowable L/D (L = distance between the ignition source and the installation location of the flame arrester, D = pipe diameter) is not exceeded and that the in-line deflagration flame arresters are not installed too far from the ignition source, so that they are not subject to a detonation because the path is too long. The allowable L/D is stated in the manufacturers manual of the flame arrester.

Selection

The effectiveness of flame arresters must be tested and approved. Flame arresters are categorized according to the combustion process and the installation site.

The selection criteria are described in the appropriate volumes. The different variations and wide range of types arises from the tailored solutions for different applications. PROTEGO® flame arresters are generally service-friendly due to the modular design of the flame arrester unit. Special details of the design (patented Shock Wave Guide Tube Effect SWGTE or Shock-absorber) enable a superior flow due to the minimum pressure loss.

Location of Installation	End-of-line			On-equipment	In-line		
	Atmospheric deflagration	Atmospheric deflagration and short time burning	Atmospheric deflagration and short time burning and endurance burning		In-line deflagration	Stable detonation and in-line deflagration	Unstable and Stable detonation and in-line deflagration
Combustion process				Pre-volume deflagration	In-line deflagration	Stable detonation and in-line deflagration	Unstable and Stable detonation and in-line deflagration
Application example		→ Tank, page 35 → Reactor, page 36 → Free venting, page 37		→ Blower → Vacuum pump (p. 40)		→ For vent header, page 35 → Combustion system, page 37 → Vapour return, page 38	
Products	→ Volume 2	→ Volume 2	→ Volume 2	→ Volume 3	→ Volume 3	→ Volume 4	→ Volume 4

PROTEGO® has the right flame arrester for all applications

- End-of-line flame arresters for atmospheric deflagrations: PROTEGO® Deflagration Flame Arresters, end-of-line, Volume 2
- End-of-line flame arresters for atmospheric deflagrations and short time burning: PROTEGO® Deflagration Flame Arresters, short time burning proof, end-of-line, Volume 2
- End-of-line flame arresters for atmospheric deflagrations and short time and endurance burning: PROTEGO® Deflagration Flame Arresters, endurance burning proof, end-of-line, Vol. 2

- Pre-volume flame arresters on equipment: PROTEGO® Deflagration Flame Arrester units on equipment, Volume 3
- In-line flame arresters for deflagrations: PROTEGO® Deflagration Flame Arresters, in-line, Volume 3
- In-line flame arresters for deflagrations and stable detonations: PROTEGO® Detonation Flame Arresters, in-line, Volume 4
- In-line flame arresters for deflagrations as well as stable and unstable detonations: PROTEGO® Detonation Flame Arresters, in-line, Volume 4



Development

Closed vessels or tanks filled with liquid products must have an opening through which the accumulated pressure can be released so that the vessel does not explode. Along the same lines, a vacuum has to be compensated for when the tank or vessel is drained so that it does not implode. Unallowable overpressure and negative overpressure will accumulate with loading and unloading procedure, steam cleaning processes, blanketing and thermal effects. Free openings enable a free exchange with the atmosphere or with connected pipe systems that are uncontrolled and unmonitored. Vent caps are used in this case (Fig. 1).



Figure 1: Free venting of the storage tank with PROTEGO® EH/OS

The vented product vapours can be poisonous, odorous, flammable, or simply represent the loss of product. They pollute the atmosphere.

The local concentration of chemical and processing plants and the associated environmental pollution have increased so much over the last 50 years, that valves are now to be used, especially in industrially developed countries, to keep the free opening cross-sections closed during operation and only permit emergency venting or relief.

The ventilation devices, which are in the form of pressure and vacuum relief valves, should not be shut off (Fig. 2).

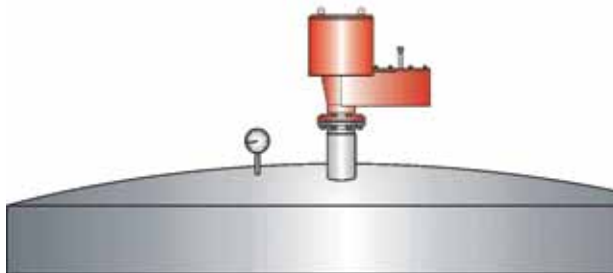

Figure 2: Venting of the storage tank with pressure and vacuum relief valve PROTEGO® VD/SV

These valves need to be simple and robust valves that do not require remote control, are trouble-free and reliably fulfill expected tasks: Maintaining and compensating pressure and vacuum.

Valve Technology

PROTEGO® pressure and vacuum relief valves have weight-loaded or spring-loaded valve pallets. When there is excess pressure in the tank, the pressure valve pallet guided in the housing lifts and thereby releases the flow into the atmosphere (Fig. 3a) until the pressure falls below the set pressure. The valve then reseats. The vacuum side of the valve is tightly sealed by the additional overpressure load. When there is a vacuum in the tank, the overpressure of the atmosphere lifts the vacuum disc and the tank is vented (Fig. 3b).

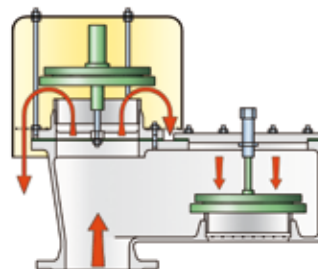

Figure 3a: Operation of the valve under pressure in the tank

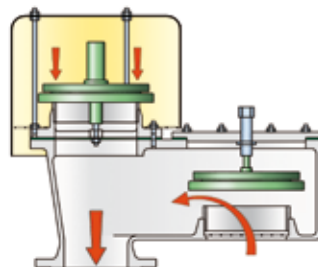

Figure 3b: Operation of the valve under vacuum (negative pressure) in the tank

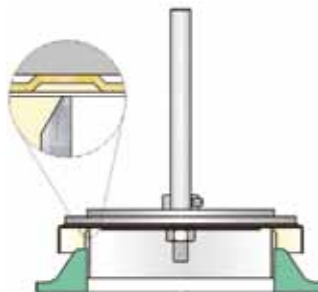

Figure 4: PROTEGO® full-lift pallet with air cushion seal

In principle, the diaphragm valve, which is loaded with liquid (as a weight), and the pilot-valve, which is self-controlled, operate in the same manner.

The weight-loaded valve pallets have different designs. A distinction is made between the full-lift pallet (Fig. 4 and Fig. 5 a, b) and the normal pallet (Fig. 6).



Technical Fundamentals

Pressure and Vacuum Relief Valves

The sealing between valve pallet and valve seat is provided by an FEP air cushion seal, a metal to metal sealing, or PTFE flat sealing depending on the set pressure or on the application. The best sealing is obtained with a metal valve disc lapped to be seated on the metal valve seat (metal to metal). When the set pressures are low, an FEP air cushion seal provides a tight seal. The tightness of the PROTEGO® valves is far above the normal standard (API2000 resp. EN ISO 28300) and hence meets the stringent demands of emission control regulations.

PROTEGO® **pressure and vacuum relief valves with full-lift pallet** discharge the flow within 10% overpressure from the set pressure to a fully opened valve (full-lift).

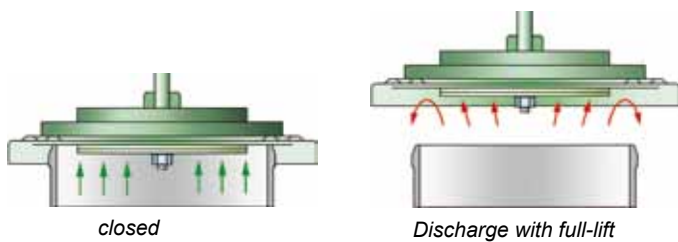

Figure 5a: Discharge with full-lift pallet and air-cushioned seal

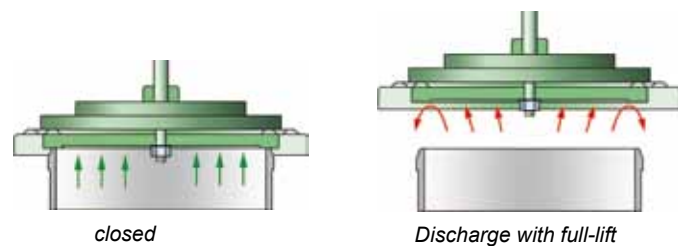

Figure 5b: Discharge with full-lift pallet and metal seal

This is attained by precisely harmonizing the diameter and height of the valve pallet rim with the adapted, machined and lapped valve seat. In addition, the flow-enhancing design reinforces the overall effect on the outflow side. These valve pallets are used in end-of-line and in-line valves.

PROTEGO® **pressure and vacuum relief valves with conventional pallets** discharge the flow within a 40% pressure.

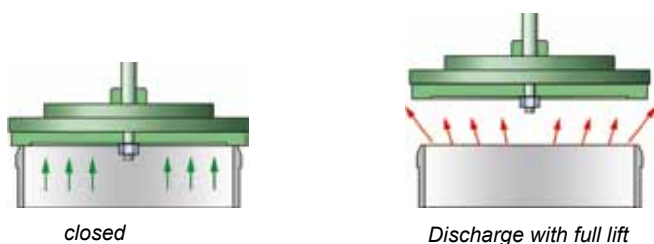

Figure 6: Discharge with normal pallet (flat with metal seal)

After the initial response, the rise in pressure is proportional to the discharged flow up to a full lift. When the back pressure in the connected pipeline is high or the valve is installed in combination with a pressure control valve, this method provides greater stability for the overall system. However, the overall flow performance is not as good as that of valves with full-lift valve pallets. These valve pallets (Fig. 6) are primarily used in in-line valves when required by operating conditions.

Depending on the design of the valve and the valve pallets, the design pressure and design vacuum (negative gauge pressure) is achieved with different overpressure (Fig. 7).

Unless otherwise agreed, the standard PROTEGO® valve design is for 10% technology.

Advantages of **PROTEGO® 10% technology**:

- Pressure conservation very close to the maximum allowable tank pressure
- Minimization of product losses
- Reduction of vapour emissions

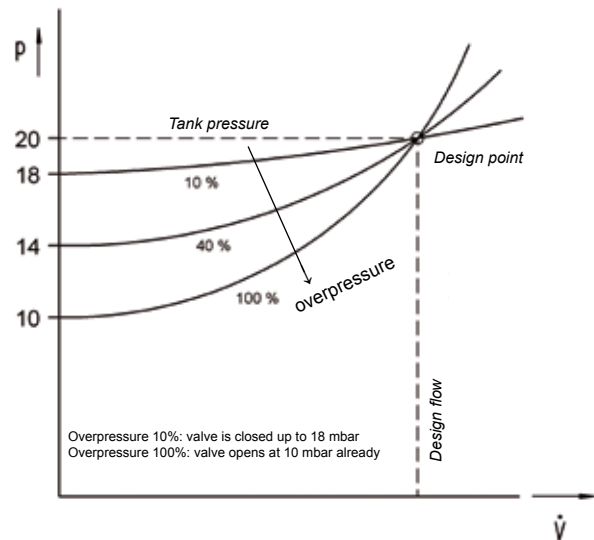

Figure 7: Opening characteristics of valves with different overpressure levels

The PROTEGO® **diaphragm valve** (Fig. 8) has a liquid load above the diaphragm.

The static liquid column is an indication of the set pressure. The flexible liquid-loaded diaphragm adjusts tightly to the metallic valve seat to provide an excellent seal. If the set pressure is exceeded, the diaphragm lifts and releases the cross-section for the flow to discharge. Due to the flexible diaphragm, these valves are used in weather-related low temperatures and in sticky, polymerizing media. PROTEGO® diaphragm valves are the only valves worldwide which are frost-proof down to temperatures of -40°C (-40°F).

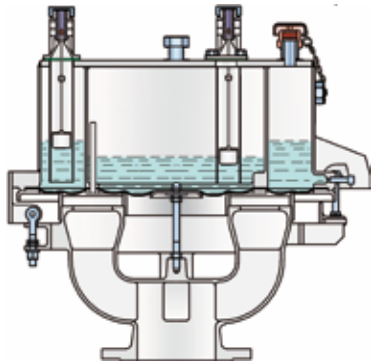

Figure 8: Diaphragm Valve PROTEGO® UB/SF-0

The self-controlled PROTEGO® pilot operated valve (Fig. 9) discharges the flow without requiring additional overpressure. Up to the set pressure until the pilot reacts, the valve remains sealed; it immediately opens in a full-lift after the set pressure is reached without overpressure and releases the cross-section of the valve (set pressure = opening pressure). As the pressure increases, the seal increases up to the set pressure. Once the flow is discharged and the pressure falls below the opening pressure, the valve recloses. PROTEGO® pilot valves are generally used as safety relief valves for low-temperature storage tanks or wherever the valve must be very tightly sealed up to the set pressure.

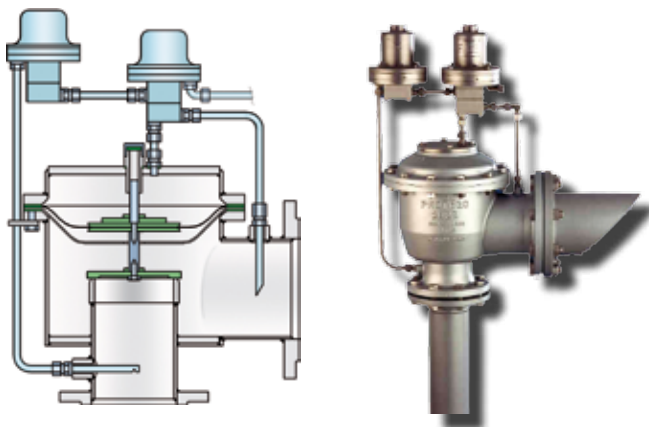

Figure 9: pilot operated pressure relief valve PROTEGO® PM/DS

The operating requirements regarding the amount of outbreathing and inbreathing capacity determine whether separate pressure valves and vacuum valves or combined pressure and vacuum relief valves are used.

Pressure and vacuum relief valves for maintaining pressure (vapour conservation)

Process-dependent pressure maintenance in systems is ensured by valves that take pressure vessel related parameters into consideration. Conventional safety valves are used for pressures above 0.5 barg (7.25 psig) according to EN-ISO 4126 and Pressure Equipment Directive (PED), API 526 and ASME VIII, Div.1, or other international standards. For pressures below 0.5 barg (7.25 psig), the

pressure can be maintained with safety valves that are not subject to the regulations of Pressure Equipment Directive (PED). They need to meet other criteria however: Provide a good seal, be frostproof, trouble-free and easy to maintain. PROTEGO® pressure and vacuum conservation valves meet these requirements while being highly efficient, operate stable and offer safe function even at very low pressures due to the 10% technology. In addition emissions of the products are reduced.

National and international technical regulations for maintaining clean air serve as the basis for calculating savings (such as VDI 3479: "Emission Control - Marketing Installation Tank Farms", VOC Directive 1999/13/EC and 94/63/EC or API MPMS Chapter 19.1: "API Manual of Petroleum Measurement Standards - Chapter 19, Evaporative Loss Measurement, Section 1 - Evaporative Loss from Fixed-Roof Tanks, 3rd Edition"). The design of the tank, the paint, the insulation, and pressure maintenance via the valves influence - among others - the reduction of emissions.

The effect that pressure maintenance has on the reduction of product (vapour) loss improves as the set pressure of the valve approaches the maximum allowable tank pressure. The flow needs to be reliably discharged without the tank rupturing. A comparison of product loss at different overpressures clearly reveals the advantages of the 10% technology over the 40% overpressure and especially in contrast to a 100% overpressure: The specially developed design yields measurable savings by decreasing the accumulation up to the required performance (Fig. 10).

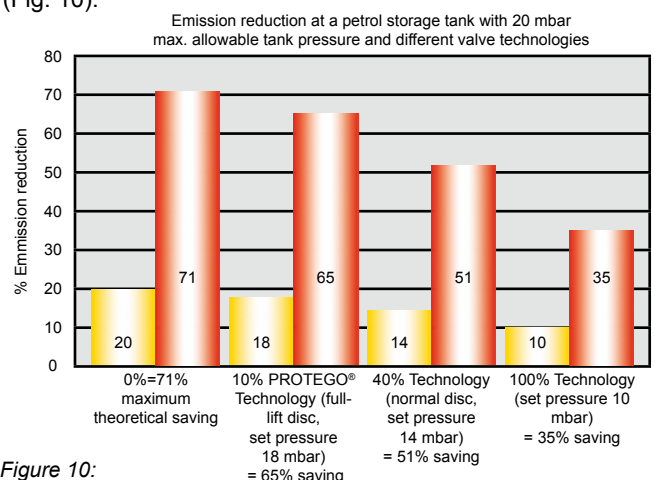

Figure 10: Stored product Petrol: Comparison of product savings at different overpressure levels versus the free vented storage tank: Example of product loss at 20 mbar allowable tank pressure savings in % at different overpressure
 0% = up to 20 mbar (8 inch W.C.) the valve is closed (theoretical): more than 70% saving,
 10% = only at a valve set pressure 18 mbar (7.2 inch W.C.) the valve opens, 65% saving,
 40% = at a valve set pressure 14 mbar (5.6 inch W.C.) the valve opens, 51% saving,
 100% = already at a valve set pressure 10 mbar (4 inch W.C.) the valve opens: only 35% saving.



Technical Fundamentals

Pressure and Vacuum Relief Valves

Pressure and Vacuum Relief Valves for Pressure Relief and Tank Breathing

Outdoor storage tanks and vessels are exposed to weather conditions such as heating up and cooling down (the tank must be able to breathe). These influences must be considered in addition to filling and emptying capacities as well as inert-gas supply. They can be calculated with good approximation (see Venting Requirements of Aboveground Storage Tanks - Sizing and Calculation Formulas, Page 26). The valve opening pressure must not exceed the maximum allowable tank pressure which also is called the tank design pressure. The construction and design of the valve determines how this opening pressure is reached. Safety valves with conventional construction designed for pressure vessels with 0.5 bar (7.25 psi) overpressure require an overpressure of 10% above the set pressure to attain the opening pressure. Below 1 bar (14.5 psi) pressure, the maximum overpressure may reach 100 mbar (4 inch W.C.), which is clearly above the 10% level. In contrast, PROTEGO® valves with the relevant technology meet the requirements of conventional safety valves with an overpressure of 10% even at low set pressures down to 0.003 bar (1.2 inch W.C.).

Under normal operating conditions, it must be impossible to block off the venting system on the tank. The sizing of the pressure and vacuum relief system must be such, that the design pressure, i.e. the pressure and vacuum (negative pressure) in the tank, can not be exceeded under any operating conditions. The **pressure and vacuum relief valve** must be designed for maximum flow arising from the pump capacity, thermal and other influences. This valve is frequently called the vent valve.

When extremely high venting rates are required due to fire on the outside surface of the tank or malfunctions in special tank equipment (such as tank blanketing gas systems), additional **emergency pressure relief valves** must be used, especially when the tank roof does not have a weak seam (Fig. 11).

When a blanket gas system fails, large amounts of gas can flow into the tank. The excess gas must be discharged from the tank through the pressure relief system without exceeding the tank design pressure.

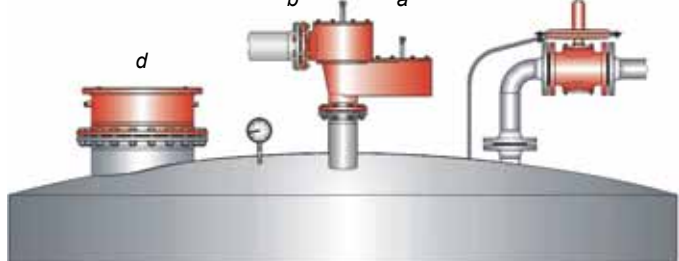

Figure 11: Venting of the storage tank with a pressure and vacuum relief valve PROTEGO® VD/SV-PA (a), piped into the vent header during operation (b), venting during operation via the nitrogen control valve PROTEGO® ZM-R (c), relieving in a fire-case through the emergency pressure relief valve PROTEGO® ER/V (d)

PROTEGO® valves fulfill the above mentioned functions of maintaining and relieving pressure as **pressure relief valves, vacuum relief valves, or combined pressure and vacuum relief valves.**

Location of installation

In general, PROTEGO® end-of-line valves are used for storage tanks, vessels or for ventilation lines. In pipes, PROTEGO® in-line valves are used as overflow valves, for backflow prevention and occasionally as control valves. The great advantages are their simple design and large opening cross-sections. These valves operate trouble-free.

If the flowing products are explosive, in-line valves must have upstream flame arresters to protect the system against accelerated combustions. End-of-line valves in this case of hazardous application, must be equipped with an end-of-line flame arrester to protect the system against atmospheric deflagration (see also Vol. 7).

Sizing of the Valves

The maximum possible volumetric flow, the maximum permissible pressures, and the operating data (process parameters) must be taken into account when sizing pressure/vacuum relief valves.

Definitions:

Set pressure = the valve starts to open = adjusted set pressure of the valve at 0 bar back pressure

Opening pressure = set pressure plus overpressure

Reseating Pressure = Closing pressure = the valve recloses and is sealed

Overpressure = pressure increase over the set pressure

Accumulation (ISO) = pressure increase over the maximum allowable tank pressure of the vessel allowed during discharge through the pressure relief valve

Accumulation (EN) = differential pressure between the set pressure of the valve and the tank pressure at which the required flow rate is reached or the set vacuum of the valve and the tank internal negative pressure at which the required flow rate is reached (not used in this catalog)

Pressure loss = decrease in pressure within the valve at a given flow

Pressure loss curve (Flow Chart) = performance curve in the flow chart = the characteristics of the valves as the pressure in mbar (inch W.C.) plotted against the flow in m³/h (CFH)

Back pressure = pressure in the system, that acts against the flow out of the valve and that needs to be included as additional pressure on the valve pallet

The maximum allowable design pressure of an equipment, storage tank or vessel may not be exceeded. The maximum possible flow must be reliably discharged through the valve so that the maximum allowable design pressure of the equipment is not exceeded. Safety factors must be taken into account.

Operating states of pressure and vacuum relief valves: The valve is optimally sized when the operating point lies on the performance curve, i.e., when the attained maximum flow is discharged with the valve completely open without requiring an additional overpressure (with completely open valve) (full-load operating range A, Fig. 12).

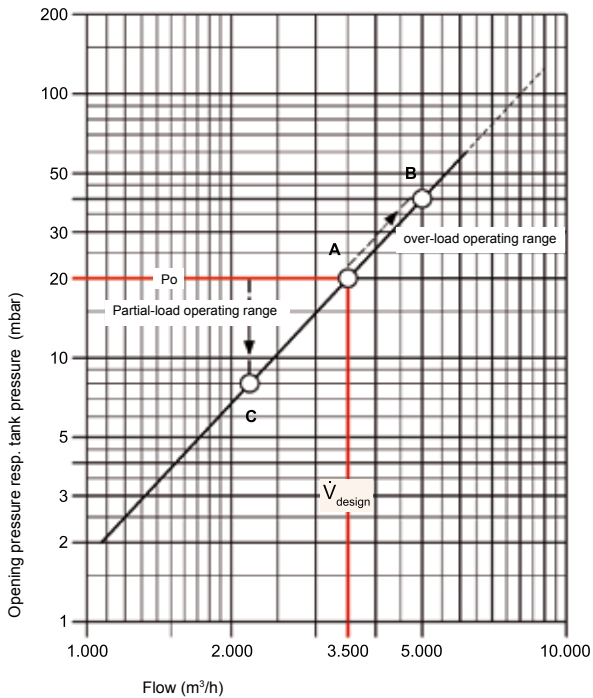

$$\text{set pressure} = \frac{\text{opening pressure resp. tank design pressure}}{1 + \frac{\text{overpressure \%}}{100\%}}$$

Figure 12: Design and operating points in the flow chart

When the design flow is not being reached during discharge the valve does not open completely. The valve pallet only lifts briefly, discharges the volume, and then recloses when the pressure falls below the set pressure. The reseating pressure depends on the design of the valve pallet and the geometry of the valve. There are partial-load operating ranges in which the full-lift is not reached (over-sized valves) and overload ranges in which an additional overpressure is required after a full lift to discharge the flow (under-sized valves). Within the overload range, the valve is stable; in the partial load range, the valve pallet can flutter due to instability. A proper sizing that takes possible operating conditions into consideration is therefore essential.

Example (Fig. 12):

- Valve opening pressure $P_o = 20 \text{ mbar}$
- Valve set pressure $P_{\text{set}} = 18 \text{ mbar (20 mbar - 10\%)}$
- A design flow $\dot{V}_{\text{design}} = 3.500 \text{ m}^3/\text{h}$
- B over-load $\dot{V} > \dot{V}_{\text{design}}$
- C partial-load $\dot{V} < \dot{V}_{\text{design}}$

For sizing of combined single component devices, which have not been flow tested as combined devices (e.g. DR/ES with DV/ZT), a special sizing process needs to be considered. Please contact our sales engineers for specific guidance.

Selection

The valves are selected using the above selection criteria depending on the **location of installation** and whether the valve is to **function** as a pressure relief valve, vacuum relief valve, or combined pressure and vacuum relief valve.

Location of Installation	End-of-line Valves				In-line Valves		
Function	Pressure Relief Valves	Vacuum Relief Valves	Pressure and Vacuum Relief Valves	Pressure Relief and Vacuum Valves, pilot operated	Pressure or Vacuum Relief Valves	Pressure and Vacuum Relief Valves	Blanketing Valves
Example of Use	→ Storage tank, page 35				→ Vent header, page 35		
Product	→ Volume 5	→ Volume 5	→ Volume 5	→ Volume 5	→ Volume 6	→ Volume 6	→ Volume 6

PROTEGO® has the right valve for all applications

For venting of storage tanks and vessels

- PROTEGO® Pressure and Vacuum Relief Valves, end-of-line (Vol. 5)

As overflow valves or backflow preventers

- PROTEGO® Pressure or Vacuum Relief Valves, in-line (Vol. 6)

For venting of tanks storing products at low temperatures and storing critical products

- PROTEGO® Pressure / Vacuum Relief Diaphragm Valves, end-of-line (Vol. 5)



for safety and environment

Development

When storing flammable products or processing chemical products that can create explosive mixtures, the opening of the storage tank or vessel must be additionally protected with flame arresters. The task was to develop a device that combined the properties of a flame arrester and a valve into one design.

PROTEGO® valves with integrated flame arrester units have the unique advantage that the flame arrester units are external and hence easily accessible (Fig. 1 and 2).

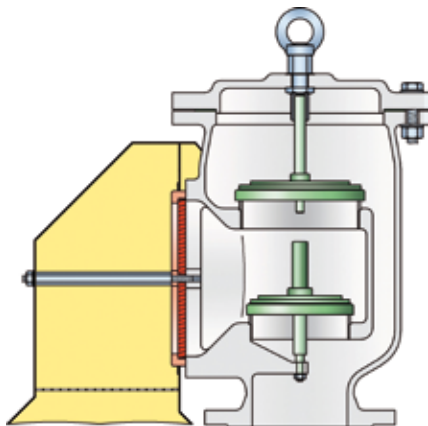

Figure 1:
Deflagration-proof pressure and vacuum relief valve PROTEGO® VD/TS

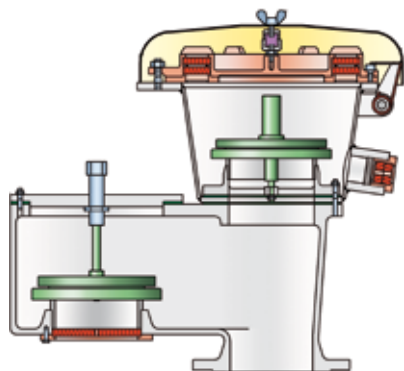

Figure 2:
Pressure and vacuum relief valve protecting against deflagration and endurance burning PROTEGO® VD/SV-HR

The operating conditions must be carefully considered. Depending on the possible combustion processes, protection must be provided against atmospheric deflagration, and/or short time burning, and/or endurance burning.

Valve Technology

The valve technology and function of the pressure and vacuum valves with integrated flame arrester units are equal to those without flame arrester units. It must be realized that the downstream flame arrester unit creates a certain back pressure which has no impact on the set pressure but influences the over-pressure behaviour. This is considered in the flow charts.

Pressure and Vacuum Relief Valves with Flame Arrester

Pressure and vacuum relief valves with integrated flame arrester units have the same tasks and functions as valves without flame arrester. They serve to **maintain pressure (vapour conservation)**, **relief pressure** and enable **tank breathing**. For a detailed description, see page 21.

Flame Arrester

The valves also have an **integrated flame arrester unit**. The explosion group of the chemical products to be protected needs to be considered in the flame-transmission-proof selection of the valve. The chemical products are categorized into explosion groups according to the maximum experimental safe gap (MESG) of the mixtures. The valve is tested and approved for the explosion group.

The PROTEGO® **diaphragm valve** (Fig. 3) has a liquid load above the diaphragm. The static liquid column is proportional to the set pressure. The flexible liquid-loaded diaphragm adjusts tightly to the metal valve seat to provide an excellent seal. If the set pressure is exceeded, the diaphragm lifts and releases the cross-section for the discharging flow. Due to the flexible diaphragm, these valves are used in weather-related low temperatures and for sticky, polymerizing media.

The PROTEGO® **diaphragm valve** (Fig. 3a) offers dynamic flame-transmission protection against endurance burning and atmospheric deflagrations.

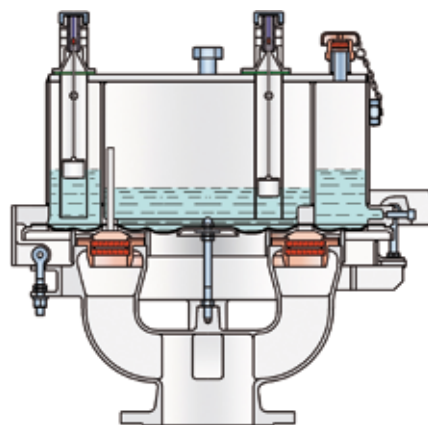

Figure 3: Diaphragm valve PROTEGO® UB/SF protecting against deflagration and endurance burning



Figure 3a: Endurance-burning test with diaphragm valve PROTEGO® UB/SF

The **high velocity valve** (Fig. 4) has special flame-transmission protection with a dynamic discharge between the valve cone and valve seat starting at a set pressure of +60 mbar (24 inch W.C.). The high velocity valve is endurance burning proof.



Figure 4: Endurance burning-proof high velocity valve PROTEGO® DE/S with a connected deflagration-proof vacuum valve PROTEGO® SV/E-S

Location of installation

Valves with flame arrester units are always end-of-line valves since the heat must be released to the environment with no heat build-up to prevent transmission of flame. Otherwise the unallowable heat build-up would effect a heat accumulation at the flame arrester which finally results in a flash-back. They are primarily used for storage tanks and containers in which flammable liquids are stored or processed and for relief openings in process containers in which the occurrence of explosive mixtures cannot be excluded.

Design and operating states of valves

The sizing and operating states of the pressure and vacuum relief valves are described on pages 22 and 23.

Selection

Since PROTEGO® pressure/vacuum relief valves with flame arrester units are always end-of-line valves, they are selected taking into consideration their function as a pressure valve, vacuum valve, or combined pressure and vacuum relief valve.

After the explosion group of the products and the possible combustion process have been determined, the valve can be selected regarding its flame-transmission protection. When selecting PROTEGO® valves with a flame arrester unit, one must establish whether flame-transmission protection is to be provided against atmospheric deflagrations or endurance burning. Endurance burning flame arresters include protection against atmospheric deflagrations. Flame-transmission-proof vacuum relief valves are deflagration-proof. The danger of a stabilized burning does not exist for vacuum relief valves.

Location of Installation	End-of-line Valve				
Function	Pressure Relief Valve with Flame Arrester	Vacuum Relief Valve with Flame Arrester	Pressure and Vacuum Relief Valve with Flame Arrester	Pressure- / Vacuum Relief Diaphragm Valve with Flame Arrester	High Velocity Valve
Example of Use	→ Storage tank, Emergency venting / pressure relief, page 35				→ Storage tank, Tank ships, page 38
Products	→ Volume 7	→ Volume 7	→ Volume 7	→ Volume 7	→ Volume 7

PROTEGO® has the right valve for all applications.

For flame-transmission-proof pressure and vacuum relief of storage tanks and containers

- PROTEGO® Pressure and Vacuum Relief Valves with Flame Arresters, end-of-line

For frost-proof application, for critical products, and for flame-transmission-proof pressure and vacuum relief of tanks and containers

- PROTEGO® Pressure -/ Vacuum Relief Diaphragm Valves

For flame-transmission-proof pressure and vacuum relief of tank ships

- PROTEGO® High Velocity Valves



for safety and environment

Technical Fundamentals

Venting Requirements of Aboveground Storage Tanks - Sizing and Calculation Formulas

Pressure Terms and Definitions

Tanks storing flammable and non-flammable liquids are designed and manufactured in accordance to different standards: EN 14015, API 620 or API 650 are the most important standards worldwide. Depending on the standard different maximum tank pressures are allowable to relief the required massflow.

Fig. 1 shows the most common terms for tanks and valves. This comparison clarifies the sizing of end-of-line relief valves featuring the 10% overpressure technology with a set pressure

adjusted only 10% below the opening pressure. In accordance to **EN 14015** and **API 650** (**Fig. 1A** and **1B**) the design pressure or **MAWP = Maximum Allowable Working Pressure** of the tank must not be exceeded not even in fire-case or system mal-function. Following **API 620** (**Fig. 1C**) the valve must relief the required regular massflow out of thermal influences and pumping at 10% above the design pressure (in general the MAWP) at the latest. For fire-case or emergency an overpressure of 20% is allowable: after exceeding the MAWP by maximum 20% the required emergency massflow must be

Figure 1: Comparison of pressure terms for storage tanks and vent valves designed and manufactured in accordance to different standards (e.g. API 620 or API 650 or EN 14015) equipped with pressure relief devices (illustration simplified and based on 10% overpressure technology of the valve). The different definition of the term accumulation is explained on Page 22.

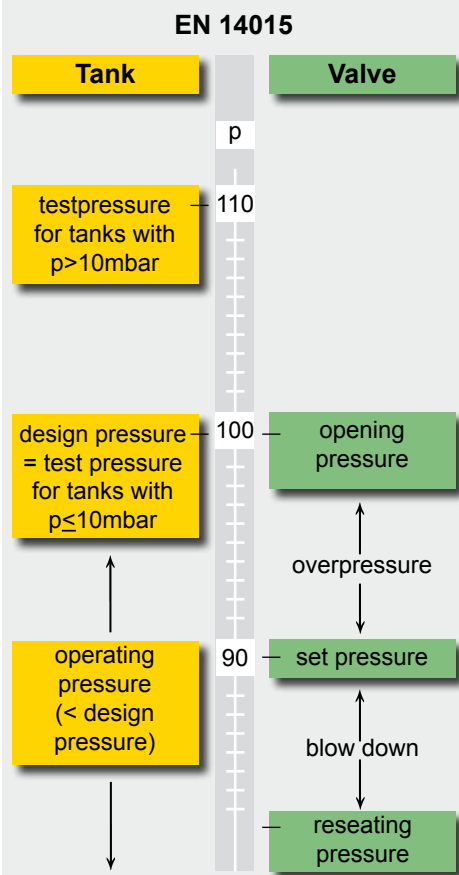

% of design pressure = p = % of opening pressure

design pressure
= calculated pressure = Maximum Allowable Working Pressure (MAWP) to be not exceeded at all operating conditions. For fire and emergency conditions weak roof to shell attachment or emergency relief valves to be provided.

opening pressure
 \leq design pressure;
set pressure = 0,9 x opening pressure for 10% overpressure technology.

Figure 1A

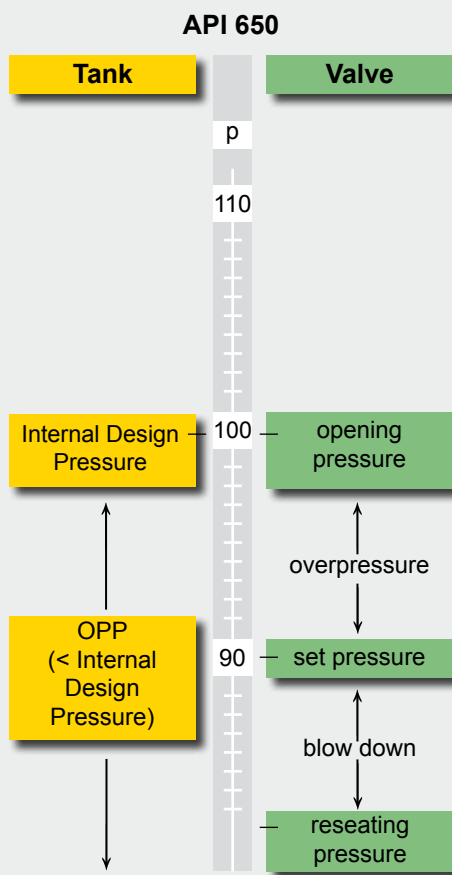

% of MAWP = p = % of opening pressure

internal design pressure
= max. relieving pressure under operating condition, fire condition or emergency (max. relieving pressure for valve and emergency valve).

OPP = Operating Pressure

opening pressure
 \leq internal design pressure
set pressure = 0,9 x opening pressure for 10% overpressure technology.

Figure 1B

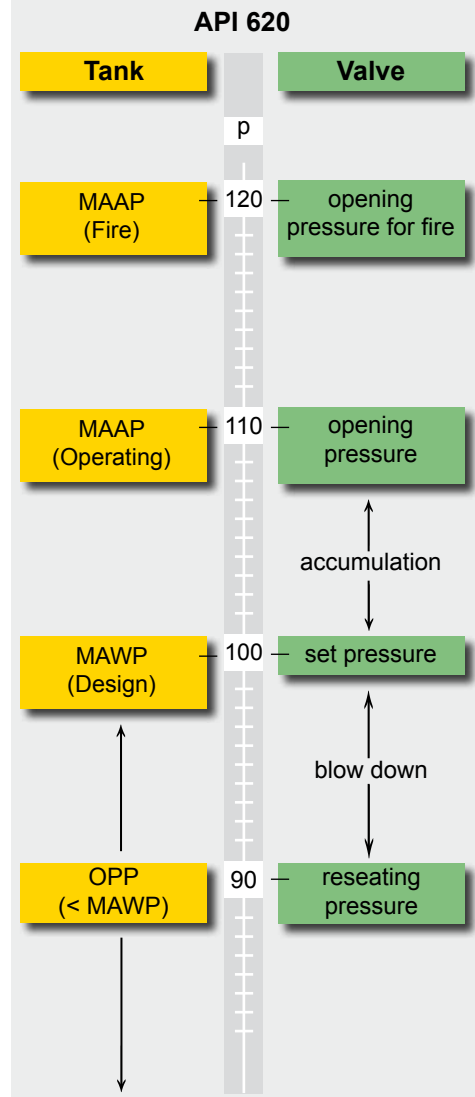

% of MAWP = p = % of set pressure

MAAP
= Maximum Allowable Accumulated Pressure = max. relieving pressure under operating condition (max. relieving pressure for valve). Relief Pressure for fire-case or emergency condition relief at 20% excess overpressure.

Max. allowable set pressure
= MAWP for 10% overpressure technology. MAWP = Maximum Allowable Working Pressure

Figure 1C



relieved. **Fig. 2** shows the procedure to determine the set pressure for valves with different overpressure characteristics by considering the specific tank design pressure. These examples are for end-of-line relief valves only without a back-pressure originated by e.g. connected pipe-away-line. If the tank is designed in accordance to EN 14015 or API 650 the opening pressure must not exceed the design pressure (=MAWP) of the tank (Fig. 2A). The set pressure

is a result of the opening pressure minus the overpressure of the valve which is a characteristic of the specific valve. If the tank is manufactured in accordance to API 620 the opening pressure may exceed the tank design pressure by 10% for regular breathing and 20% for fire-case (Fig. 2B). The set pressure again is the result of the opening pressure minus the valve-characteristic overpressure.

Figure 2:
Selection of the set pressure of the Pressure or Vacuum Relief Valve considering the tank design pressure and the valves characteristic overpressure (e.g. 10%, 40% or 100%). API 620 using the 20% overpressure allowance for fire emergency.

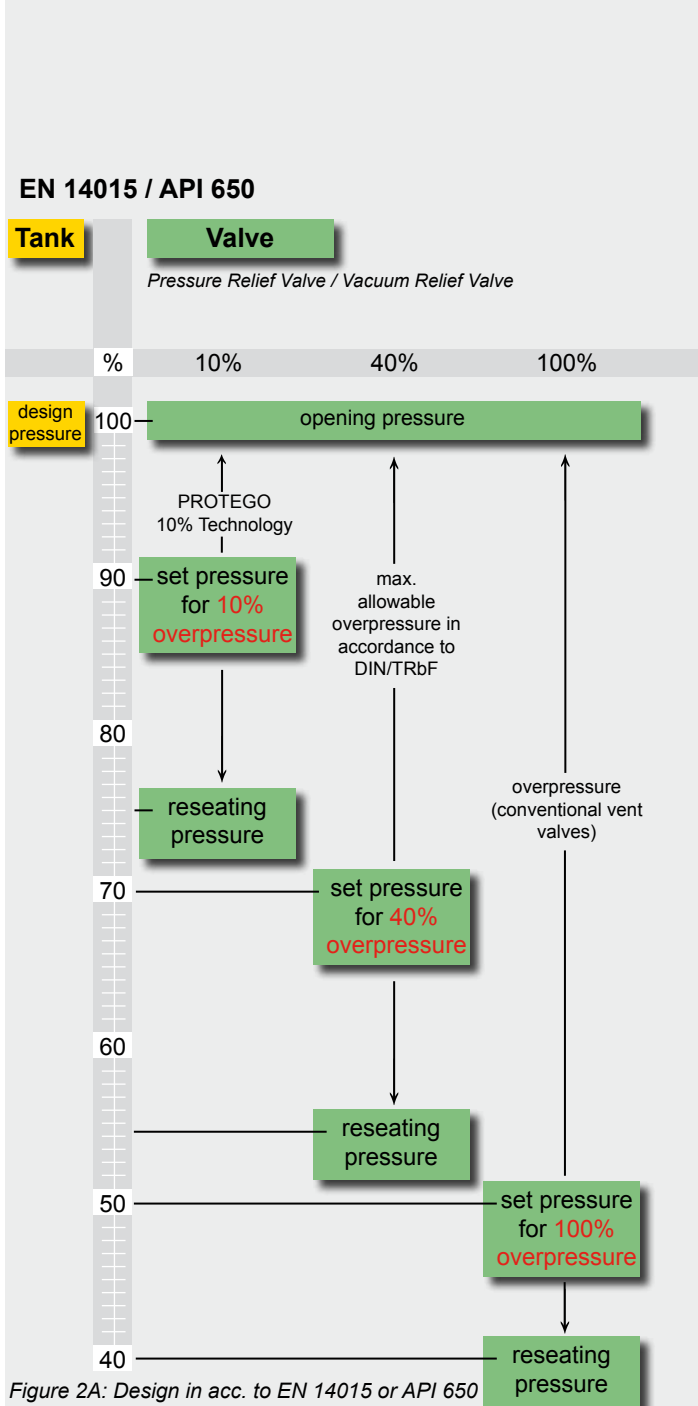

Figure 2A: Design in acc. to EN 14015 or API 650

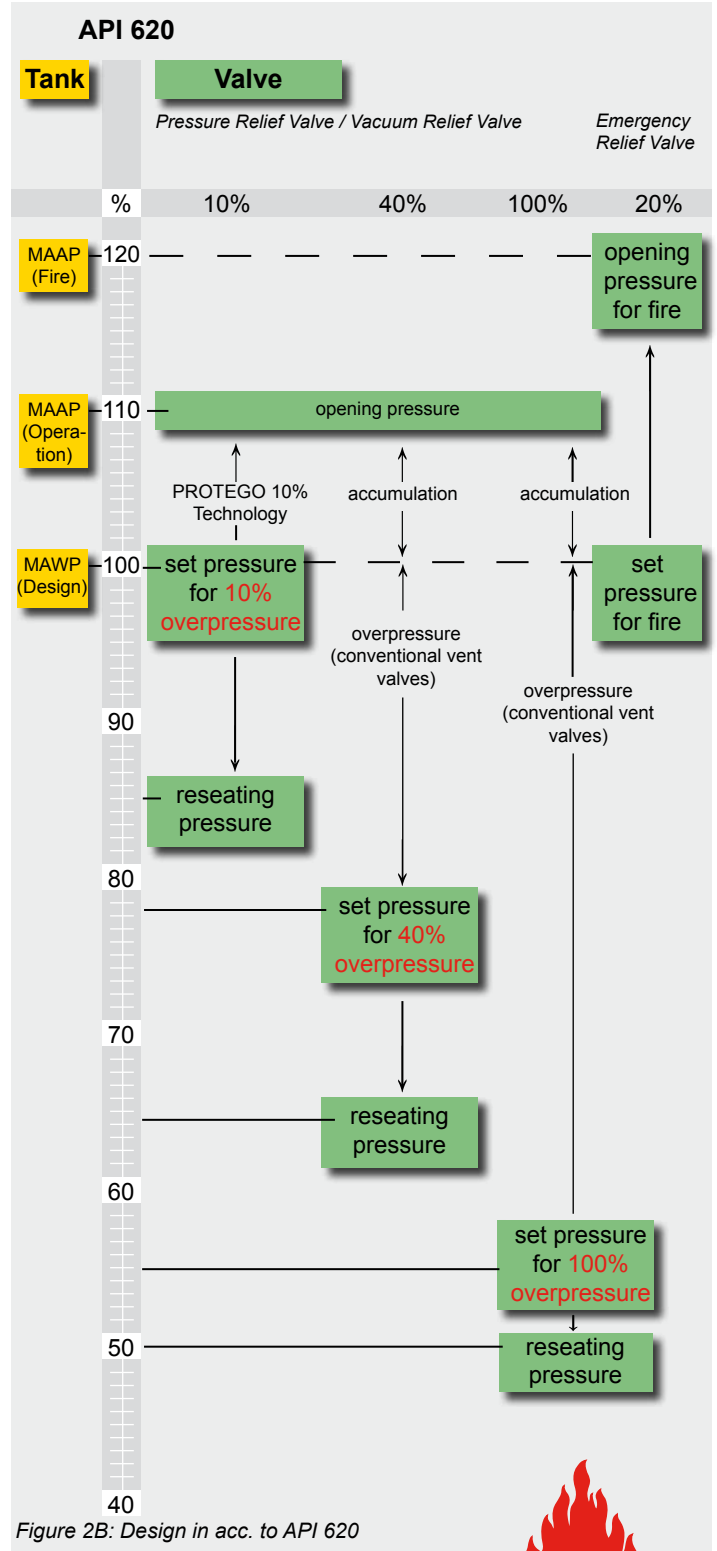

Figure 2B: Design in acc. to API 620



Calculation of the Out- and Inbreathing venting capacity in acc. to ISO 28300/API 2000:

The maximum required venting capacity is the total amount of pump capacity and capacity out of thermal influences:

$$\dot{V}_{out} = \dot{V}_{thermal\ out} + \dot{V}_{pump\ in}$$

$$\dot{V}_{in} = \dot{V}_{thermal\ in} + \dot{V}_{pump\ out}$$

The calculation of the maximum required capacity out of the thermal influences is based on ISO 28300 with regard to above-ground storage tanks with or without insulation.

Thermal capacity for heating up $\dot{V}_{thermal\ out}$ in m³/h

$$\dot{V}_{thermal\ out} = 0,25 \cdot V_{Tank}^{0,9} \cdot R_i$$

Thermal capacity for cooling down $\dot{V}_{thermal\ in}$ in m³/h

$$\dot{V}_{thermal\ in} = C \cdot V_{Tank}^{0,7} \cdot R_i$$

- V_{Tank} is the volume of the tank in m³

$$V_{tank} = 0,7854 \cdot D^2 \cdot H$$
- R_i is a reduction factor for insulation (see ISO 28300/API 2000)
- $\dot{V}_{pump\ in}$ is the filling rate to calculate the outbreathing capacity out of the maximum pump capacity in m³/h for products stored below 40°C and a vapour pressure $p_{vp} < 50$ mbar. For products stored at a temperature above 40°C or with a vapour pressure $p_{vp} > 50$ mbar the out-breathing rate must be increased by the evaporation rate.
- $\dot{V}_{pump\ out}$ is the emptying rate to calculate the inbreathing capacity of the pump in m³/h.
- C=3 for products with equal vapour pressure as hexane and storage temperature < 25°C
- C=5 for products with vapour pressures higher than hexane and/or storage temperature above 25°C (if vapour pressure not known, then C=5)

The mentioned calculation formulas are valid for latitudes 58° to 42°; other latitudes see ISO 28300/API 2000.

Particular influences to be considered are e.g.:

- Failure of the nitrogen blanketing valve – Installation of an additional emergency relief valve to vent the non calculated flow which was not foreseen under operation
- Filling the empty hot tank with cold liquid product – Considering the additional flow due to the sudden cooling down when calculating the necessary vacuum capacity
- Exceeding the maximum given pump out capacity – Considering a safety factor when calculating the required inbreathing capacity

Calculation of the Out- and Inbreathing venting capacity in acc. to TRGS 509:

To calculate the out- and inbreathing capacity of storage tanks (e.g. tanks in acc. to DIN 4119 – aboveground storage tanks or DIN 6608 – horizontal underground or buried tanks) the calculation formulas of TRGS 509 (since 1 January 2013 VdTÜV-Merkblatt Tankanlagen 967) are to be applied.

Calculation of the required capacity due to thermal influences:

$$\text{Heating up} \quad \dot{V}_E = 0,17 \times \left(\frac{H}{D}\right)^{-0,52} \times V_{Tank}^{0,89}$$

$$\text{Cooling down} \quad \dot{V}_A = 4,8 \times V_{Tank}^{0,71}$$

H = Height of the Tank in m; D = Diameter in m

Calculation of Out- and Inbreathing venting capacity in acc. to API 2000 5th edition / ISO 28300 Annex A:

The out- and inbreathing capacity of petroleum storage tanks can be calculated in acc. to ISO 28300 Annex A (approximately equivalent to API 2000 5th edition) if specific boundary conditions are fulfilled (see ISO 28300).

If required and when the tanks are specified and designed in accordance to **API 650**, the venting capacity is to be calculated in accordance to **API 2000** for in- and outbreathing as well as for emergency fire cases.

When calculating the required capacities in accordance to API 2000 5th edition / ISO 28300 Annex A, the flammable liquids must be verified with regard to their flashpoint. Different formulas must be applied for liquids with flashpoint < 100°F (< 37,8°C) and for liquids with flashpoint ≥ 100°F (≥ 37,8°C). The maximum required venting capacity is the total amount of pump capacity plus capacity out of thermal influences. In contrast, the calculation of the pump capacity must consider a factor for the inbreathing rate and the different flashpoints for the outbreathing rate.

Calculation of the inbreathing capacity:

$$\dot{V}_{in} = \dot{V}_{pump\ out} \times 0,94 + \dot{V}_{thermal\ in}$$



QuEST - Quick Engineering and Sizing Tool

The thermal capacity $\dot{V}_{thermal, in}$ is rated in API 2000 5th ed. **Fig. 2A** (English Units) and **2B** (Metric Units) depending on the tank-volume. The maximum pumping capacity $\dot{V}_{pump, out}$ is rated in accordance to the specified operating rates for emptying.

Calculation of the outbreathing capacity:

For liquids with flashpoint <100°F (<37,8°C)

$$\dot{V}_{out} = \dot{V}_{pumping\ in} \times 2,02 + \dot{V}_{thermal\ out}$$

For liquids with flashpoint ≥100°F (≥37,8°C)

$$\dot{V}_{out} = \dot{V}_{pumping\ in} \times 1,01 + \dot{V}_{thermal\ out}$$

The thermal capacity $\dot{V}_{thermal, out}$ is rated in API 2000 5th ed. **Fig. 2A** (English units) and **2B** (Metric Units) depending on the tank-volume and the flashpoint. The maximum pumping capacity $\dot{V}_{pump, in}$ is rated in accordance to the specified operating rates for filling.

In case there is no weak roof-to-shell attachment, the venting for fire emergency case is to be realized through an emergency pressure relief valve. The required capacity for fire emergency case \dot{V}_{fire} is rated in accordance to API 2000 **Fig. 3A** (English Units) and **Fig. 3B** (Metric Units) depending on the wetted surface area of the tank.

Simplified formula for estimating calculation:

$$\dot{V}_{fire} = 208,2 \times F \times A^{0,82} \text{ for Metric Units in Nm}^3/\text{h}$$

$$\dot{V}_{fire} = 1107 \times F \times A^{0,82} \text{ for English Units in SCFH}$$

Insulation is considered with a factor F in API 2000 **Fig. 4A** (English Units) and **4B** (Metric Units).

Requirements of Thermal Venting Capacity (English Units)

Tank Capacity	Tank Capacity	Inbreathing <i>thermal</i> _{in}	Outbreathing <i>thermal</i> _{out}	
			Flashpoint ≥ 100°F	Flashpoint < 100°F
Barrels	Gallons	SCFH Air	SCFH Air	SCFH Air
100	4.200	100	60	100
500	21.000	500	300	500
1.000	42.000	1.000	600	1.000
2.000	84.000	2.000	1.200	2.000
4.000	168.000	4.000	2.400	4.000
5.000	210.000	5.000	3.000	5.000
10.000	420.000	10.000	6.000	10.000
20.000	840.000	20.000	12.000	20.000
30.000	1.260.000	28.000	17.000	28.000
40.000	1.680.000	34.000	21.000	34.000
50.000	2.100.000	40.000	24.000	40.000
100.000	4.200.000	60.000	36.000	60.000
140.000	5.880.000	75.000	45.000	75.000
160.000	6.720.000	82.000	50.000	82.000
180.000	7.560.000	90.000	54.000	90.000

Excerpt of API 2000 5th ed.

Figure 2A

Requirements of Thermal Venting Capacity (Metric Units)

Tank Capacity	Inbreathing <i>thermal</i> _{in}	Outbreathing <i>thermal</i> _{out}	
		Flashpoint ≥ 37,8°C	Flashpoint < 37,8°C
m ³	Nm ³ /h	Nm ³ /h	Nm ³ /h
10	1,69	1,01	1,69
20	3,37	2,02	3,37
100	16,90	10,10	16,90
200	33,70	20,20	33,70
300	50,60	30,30	50,60
500	84,30	50,60	84,30
1.000	169,00	101,00	169,00
2.000	337,00	202,00	337,00
3.000	506,00	303,00	506,00
4.000	647,00	388,00	647,00
5.000	787,00	472,00	787,00
10.000	1.210,00	726,00	1.210,00
20.000	1.877,00	1.126,00	1.877,00
25.000	2.179,00	1.307,00	2.179,00
30.000	2.495,00	1.497,00	2.495,00

Excerpt of API 2000 5th ed.

Figure 2B

Technical Fundamentals

Venting Requirements of Aboveground Storage Tanks - Sizing and Calculation Formulas

Emergency Venting required for Fire Exposure Versus Wetted Surface Area (English Units)

Wetted Area A square feet	Venting Requirement \dot{V} SCFH
20	21.100
40	42.100
60	63.200
80	84.200
100	105.000
140	147.000
180	190.000
250	239.000
350	288.000
500	354.000
700	428.000
1400	587.000
2800	742.000

Excerpt of API 2000 5th ed.
Figure 3A

Emergency Venting required for Fire Exposure Versus Wetted Surface Area (Metric Units)

Wetted Area A m ²	Venting Requirement \dot{V} Nm ³ /h
2	608
4	1.217
6	1.825
8	2.434
15	4.563
25	6.684
30	7.411
35	8.086
45	9.322
60	10.971
80	12.911
150	16.532
260	19.910

Excerpt of API 2000 5th ed.
Figure 3B

Environmental Factors for nonrefrigerated Aboveground Tanks (English Units)

Tank-configuration	Insulation Thickness inch	F- Factor
Bare metal tank	0	1.0
insulated tank	1	0.3
insulated tank	2	0.15
insulated tank	4	0.075
insulated tank	6	0.05
underground storage		0
earth covered storage		0.03
impoundment away from tank		0.5

Excerpt of API 2000 5th ed.
Figure 4A

Environmental Factors for nonrefrigerated Aboveground Tanks (Metric Units)

Tank-configuration	Insulation Thickness cm	F- Factor
Bare metal tank	0	1,0
insulated tank	2,5	0,3
insulated tank	5	0,15
insulated tank	10	0,075
insulated tank	15	0,05
underground storage		0
earth covered storage		0,03
impoundment away from tank		0,5

Excerpt of API 2000 5th ed.
Figure 4B

Conversion of operational flow into equivalent diagram flow for use of flow charts

To use the flow charts (pressure vs. flow diagram) by considering the operational and product data, it is necessary to convert the given operational flow $\dot{V}_{B, Gas}$ into the equivalent diagram-flow \dot{V}_{Dia} . This \dot{V}_{Dia} then creates the same pressure loss as the actual operational flow.

1) Conversion of the operational flow $\dot{V}_{B, Gas}$ into the standard flow $\dot{V}_{N, Gas}$:

$$\dot{V}_{N, Gas} = \dot{V}_{B, Gas} * \frac{T_N * p_B}{T_B * p_N} = \dot{V}_{B, Gas} * \frac{p_B * 273,15 K}{T_B * 1,013 \text{ bar}_{abs}}$$

2) Conversion of the standard flow $\dot{V}_{N, Gas}$ into the equivalent diagram flow \dot{V}_{Dia} :

$$\begin{aligned} \dot{V}_{Dia} &= \dot{V}_{N, Gas} * \sqrt{\frac{\rho_{N, Gas} * p_N * T_B}{\rho_{Dia} * p_G * T_N}} \\ &= \dot{V}_{N, Gas} * \sqrt{\frac{\rho_{N, Gas} * T_B * 1,013 \text{ bar}_{abs}}{\rho_G * 1,2 \frac{\text{kg}}{\text{m}^3} * 273,15 \text{ K}}} \end{aligned}$$

3) Calculation of the average density $\rho_{N, Gas}$ of a gas-mixture

$$\rho_{N, Gas} = (v_1 * \rho_{N, Gas 1} + v_2 * \rho_{N, Gas 2} + \dots + v_x * \rho_{N, Gas x})$$

Terms

- \dot{V} = Flow m³/h (CFH)
- p = Pressure bar abs (psi abs)
- T = Temperature K
- ρ = Specific density kg/m³ (lb / cu ft)
- v = Volume fraction

Indices

- N = Standard condition (at 1,013 bar abs and 273,15 K)
- B = Operational condition (pressure and temperature in acc. to operation)
- Gas = Actual product
- Dia = Related to the Diagram, when using the flow chart for sizing (ρ_{Dia} = 1,189 kg/m³ related density of air at 20 °C and 1 bar abs.)
- G = related to the outlet of the device (p_G back pressure) for operating conditions



for safety and environment

Technical Fundamentals

Venting Requirements of Aboveground Storage Tanks - Sizing and Calculation Formulas

Safety Proceeding to Protect Hazardous Explosive Areas in Third-Party-audited processing plants

Step 1

Assessment of the possible combustion process based on Standards, e.g. EN 1127-1 General Explosion Protection Methods and EN ISO 16852 respectively EN 12874 Flame Arresters

- Deflagration in the atmosphere, in a pre-volume or in a pipeline
- Detonation in a pipeline, stable or unstable
- Endurance burning due to continuous flow of vapours/gases in the pipeline or at the opening of a tank

Step 2

Classification of the products based on literature and international standards EN ISO 16852, VbF, NFPA, British Standard for liquids, gases, vapours and multiple component mixtures

- Liquids: subdividing in flammable, easy flammable and highly flammable due to the flash point of the liquid and verifying the ignition temperature.

The classification is following the VbF (previously) and the Ordinance on Hazardous Substances (Gef. Stoff VO):

Non water soluble	
previous	actual
(A I FP < 21 °C)	FP < 0 °C (32°F) Extremely flammable FP < 21 °C (70°F) Highly flammable
(A II FP 21–55 °C)	FP 21-55°C (70-131°F) Flammable
(A III FP 55–100 °C)	-

Water soluble	
previous	actual
(B < FP 21 °C)	FP < 0 °C (32°F) Extremely flammable FP < 21 °C (70°F) Highly flammable FP 21–55 °C (70-131°F) Flammable

FP = Flashpoint

Products with a flashpoint $FP > 55^{\circ}\text{C}$ ($> 131^{\circ}\text{F}$) get flammable when being heated close to the flashpoint ($\Delta T = 5$ degree safety margin as a rule of thumb for hydrocarbons as well as 15 degree for mixtures).

Vapours: classification of the gas/vapour-air-mixtures in accordance to the MESG of the products or the mixture into the Explosion Groups IIA1, IIA, IIB1, IIB2, IIB3, IIB and IIC (page 17) (NEC Group D, C and B).

Step 3

Consideration of the operational process parameters of the unburnt mixtures with regard to the impact on the combustion behaviour:

- Operating Temperature
 $\leq 60^{\circ}\text{C}$ ($\leq 140^{\circ}\text{F}$) Standard, no particular requirements
 $> 60^{\circ}\text{C}$ ($> 140^{\circ}\text{F}$) Special approvals necessary
- Operating pressure
 $\leq 1,1$ bar abs (≤ 15.95 psi) Standard, no particular requirements
 $> 1,1$ bar abs (> 15.95 psi) Special approvals necessary

Step 4

Assessment of the overall system and classification into hazardous zones in accordance to frequency and duration of explosive atmosphere based on national and international regulations e.g. TRBS, IEC or NFPA/NEC.

- Zone 0
A place in which an explosive atmosphere consisting of a mixture of air with flammable substances in the form of gas, vapour or mist is present continuously or for long periods or frequently.
- Zone 1
A place in which an explosive atmosphere consisting of a mixture of air with flammable substances in the form of gas, vapour or mist is likely to occur in normal operation occasionally.
- Zone 2
A place in which an explosive atmosphere consisting of a mixture of air with flammable substances in the form of gas, vapour or mist is not likely to occur in normal operation but, if it does occur, will persist for a short period only.

To work out a risk assessment, the possible ignition sources must be evaluated under normal operating conditions as well as under special operating conditions like cleaning and maintenance work (see EN 1127-1):

effective ignition source:

- Steady and continuously under normal operation
- Solely as a result of malfunctions
- Solely as a result of rare malfunctions

Effective ignition sources are chemical reactions, flames and hot gases, hot surfaces, mechanical generated sparks, static electricity, lightning, electromagnetic waves, ultrasonics, adiabatic compression, shock waves etc.

Effectiveness of the ignition source is to be compared to the flammability of the flammable substance.

Step 5

Selection, number and location of the suitable Equipment, Protective System and Component must follow the requirements of national and international regulations (ATEX Directive).

For equipment (blowers, agitators, containers etc.)

- In Zone 0 equipment categorized in group II cat 1
- In Zone 1 equipment categorized in group II cat 2
- In Zone 2 equipment categorized in group II cat 3

Flame arresters tested accordingly to EN ISO 16852 resp. EN 12874 fulfill the health and safety requirements of current ATEX directive.

Flame arresters are Protective Systems and are not categorized. They must be type examination tested and approved by a Notified Body. They can be installed in all zones (zone 0, 1 or 2) and are marked with CE to state the conformity with all applicable requirements.

The procedure and the results of the risk assessment must be verified in the "Explosion Protection Document". The plant operator (employer) has to confirm that Equipment, Protective Systems and Components are in accordance with the law and are in compliance with the actual state-of-the-art. Process engineering, plant-layout, substances, zoning, risk assessment etc. are part of the protection concept and are determined in connection with the corresponding responsibilities.





PROTEGO® safety devices are used in a wide range of industrial applications. A safe process requires reliable protection for every conceivable operating parameter. Practical examples show how systems can be made safe and how PROTEGO® devices can be incorporated into control loops. Engineers are responsible for properly harmonizing the overall system.

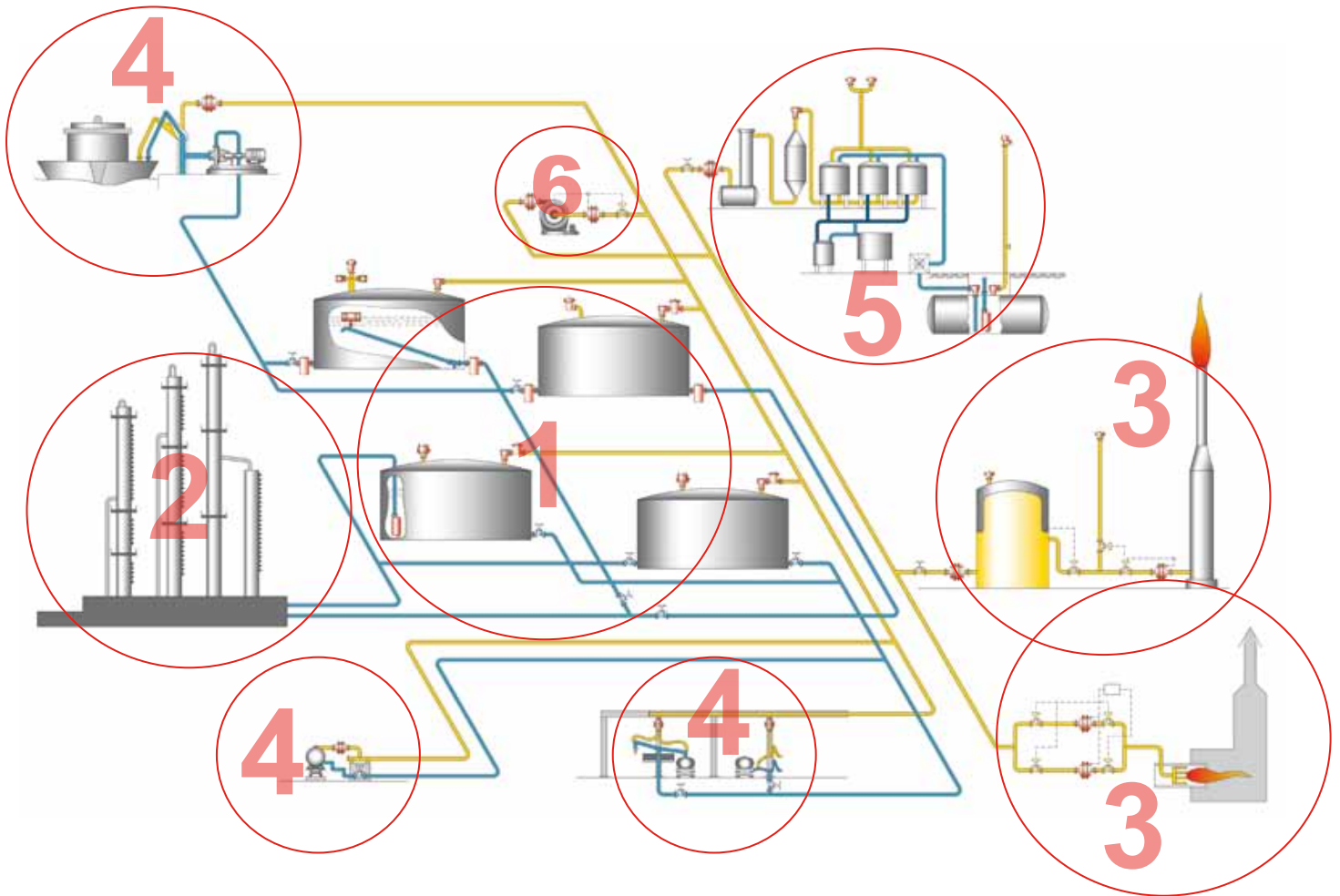

PROTEGO® devices offer safety and environmental protection

- ① In Storage Tank Farms for Refineries and Chemical Plants
- ② In Processing Systems for Chemical and Pharmaceutical Industries
- ③ In Vapour Combustion Systems and Flares
- ④ In Ship Building and Loading Systems
- ⑤ In Vapour Recovery Units
- ⑥ As integrated Component of Equipment, Machines and Vessels

Applications of PROTEGO® devices are used in other areas such as in biogas and landfill gas systems, medical technology, food processing, airplane construction, automobile construction, IT clean-rooms, thin-layer manufacturing, etc.

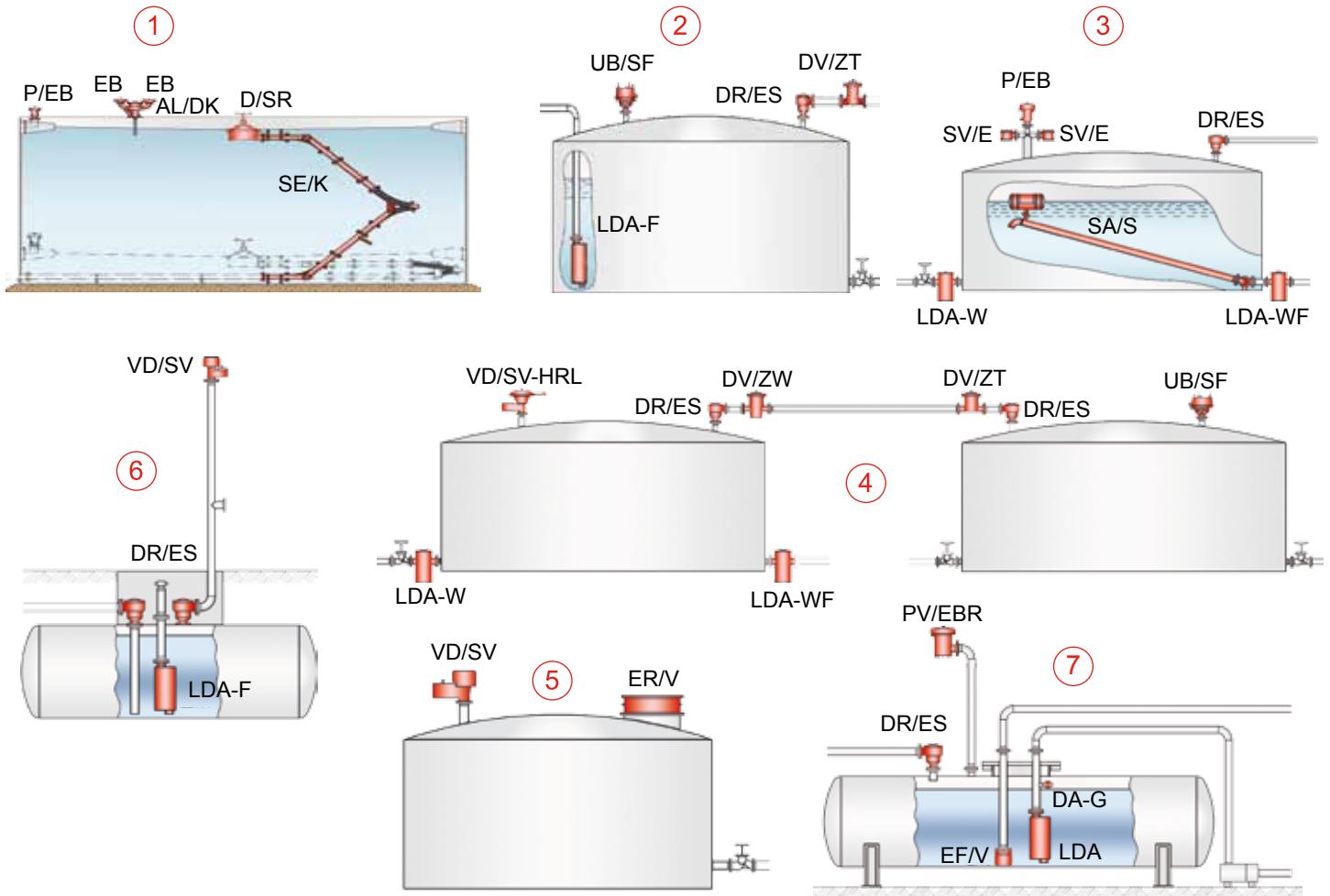

- ① Floating-roof storage tank with floating-roof drainage system SE/K (→ Volume 8), roof valve D/SR (→ Volume 8), stem-actuated valve AL/DK (→ Volume 8) with deflagration flame arresters EB (→ Volume 2)
- ② Fixed-roof storage tank for flammable liquids with pressure and vacuum diaphragm valve UB/SF (→ Volume 7), liquid detonation flame arrester LDA-F (→ Volume 4), in the protective gas blanket line DR/ES (→ Volume 4) with DV/ZT (→ Volume 6)
- ③ Fixed-roof storage tank for flammable liquids with pressure safety relief valve P/EB (→ Volume 7) and vacuum safety relief valve SV/E (→ Volume 7), liquid detonation flame arrester LDA-W (→ Volume 4) and/or LDA-W-F (→ Volume 4) in the filling and emptying line, float-controlled swing pipe system SA/S (→ Volume 8), detonation-proof gas displacement connection DR/ES (→ Volume 4)
- ④ Fixed-roof storage tank for flammable liquids with pressure and vacuum relief valve VD/SV-HRL (→ Volume 7), pressure and vacuum relief diaphragm valve UB/SF (→ Volume 7), connection to gas vent header system with detonation flame arrester DR/ES (→ Volume 4) and in-line pressure and vacuum safety relief valve DV/ZT or DV/ZW (→ Volume 6), liquid detonation arrester in the filling line LDA-W and emptying line LDA-WF (→ Volume 4)
- ⑤ Fixed-roof storage tank for non-flammable liquids with pressure and vacuum conservation valve VD/SV (→ Volume 5) and emergency pressure relief valve ER/V (→ Volume 5) instead of weak seam
- ⑥ Underground storage tank with safety devices in the filling line LDA-F (→ Volume 4), detonation flame arrester in the drain line DR/ES (→ Volume 4), and in the vent line DR/ES (→ Volume 4) and VD/SV (→ Volume 5)
- ⑦ Aboveground tank for flammable liquids with pressure and vacuum safety relief valve PV/EBR (→ Volume 7), liquid detonation flame arrester LDA (→ Volume 4) in the filling line and an additional detonation flame arrester DA-G (→ Volume 4) ensures that the tank is not emptied, detonation proof foot valve for suction line EF/V (→ Volume 4), detonation flame arrester DR/ES (→ Volume 4) in vapour return pipeline.

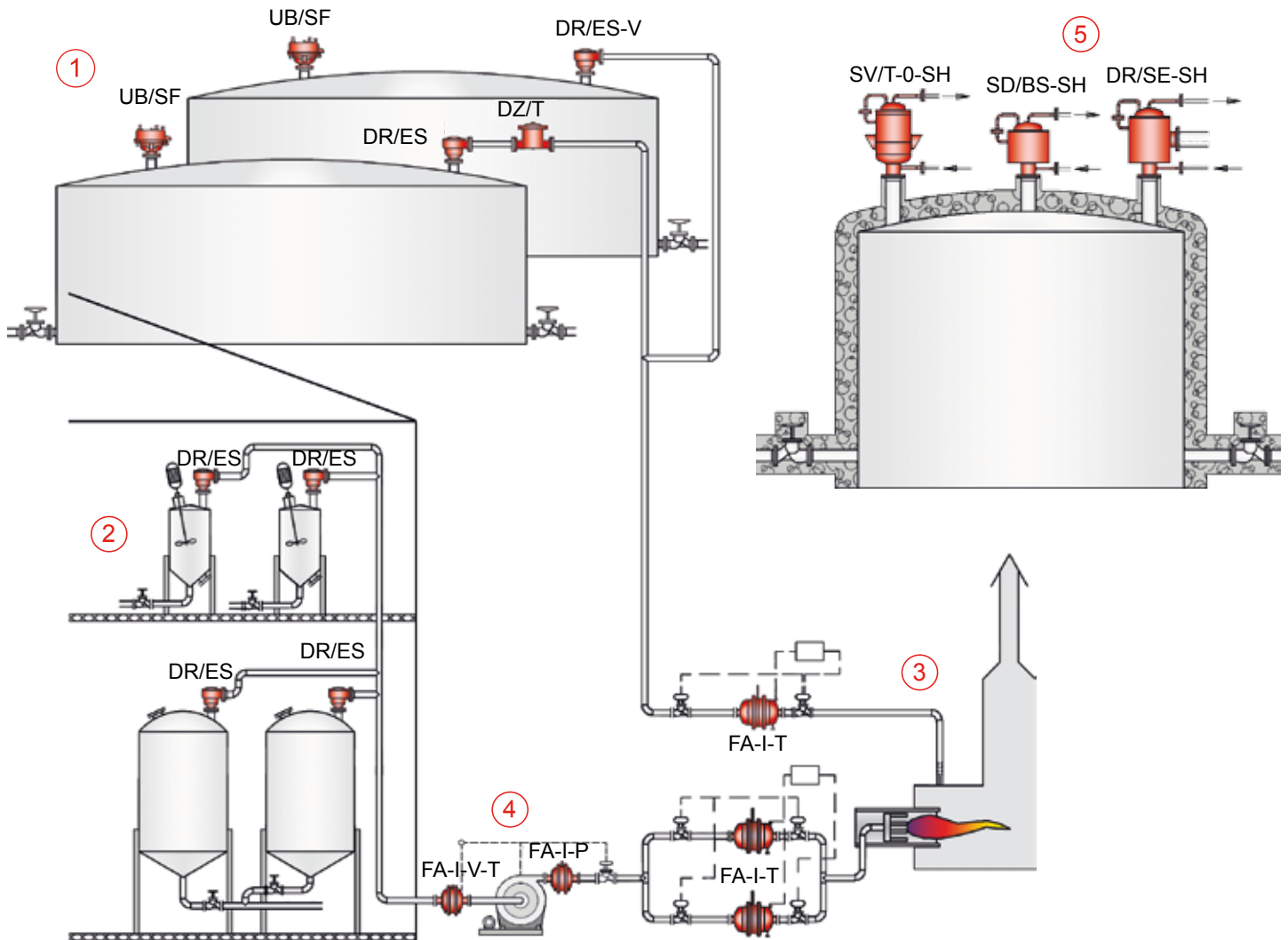

- ① Tank farms for flammable liquids with pressure and vacuum relief diaphragm valve UB/SF (→ Volume 7), connection to gas vent header system with detonation flame arrester DR/ES-V or DR/ES (→ Volume 4) and pressure or vacuum relief valve DZ/T (→ Volume 6)
- ② Ventilation of industrial mixers and process vessels in a common vapour vent header via detonation flame arresters DR/ES (→ Volume 4)
- ③ Temperature-monitored deflagration flame arresters FA-I-T (→ Volume 3) in the feed line for vapour combustion at the maximum allowable distance from the ignition source and in parallel for the sake of availability for servicing or emergency switching in case of an endurance burning on the arrester. Vapour pipeline from plant to vapour combustion unit with deflagration flame arrester FA-I-T (→ Volume 3) to protect the vent header collection line and the operating locations in the plant.
- ④ Protecting pressure-resistant radial blowers as type-examined zone-0 blowers with integrated PROTEGO® flame arresters FA-I-V-T and FA-I-P (→ Volume 3)
- ⑤ Protection of storage tanks for media that can only be pumped with assistance of heating systems. These applications, e.g. bitumen storage, need fully heated devices such as the pressure relief valve SD / BS - H (→ Volume 5), vacuum relief valve SV / T - 0 - H (→ Volume 5) and heated detonation flame arrester DR / SE – SH to a heating temperature of the heating jacket to 320 ° C at 6 bar.

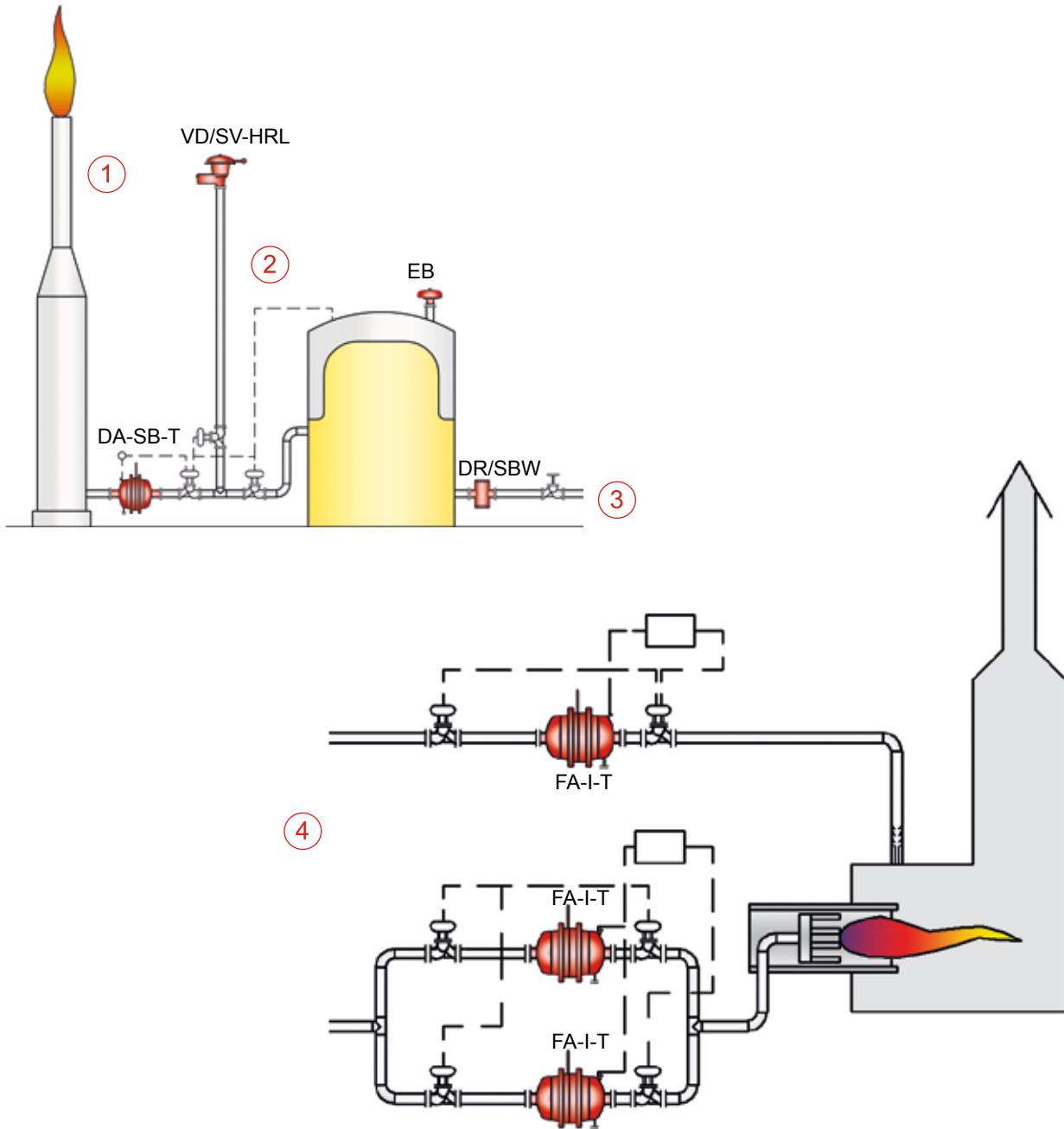

- ① Flare pipes or ground flares with detonation flame arresters DA-SB-T (→ Volume 4)
- ② Emergency pressure relief stack with endurance-burning-proof pressure and vacuum relief valve VD/SV-HRL (→ Volume 7)
- ③ Gasholder with detonation flame arrester DR/SBW (→ Volume 4) in the gas supply and end-of-line deflagration flame arrester EB (→ Volume 2), which protects against endurance burning, above the diaphragm

- ④ Temperature-monitored deflagration flame arresters FA-I-T (→ Volume 3) in the feed line for vapour combustion at the maximum allowable distance from the ignition source and in parallel for the sake of availability for servicing or emergency switching in case of an endurance burning on the arrester

Vapour pipeline from plant to vapour combustion unit with deflagration flame arrester FA-I-T (→ Volume 3) to protect the vent header collection line and the operating locations in the plant.

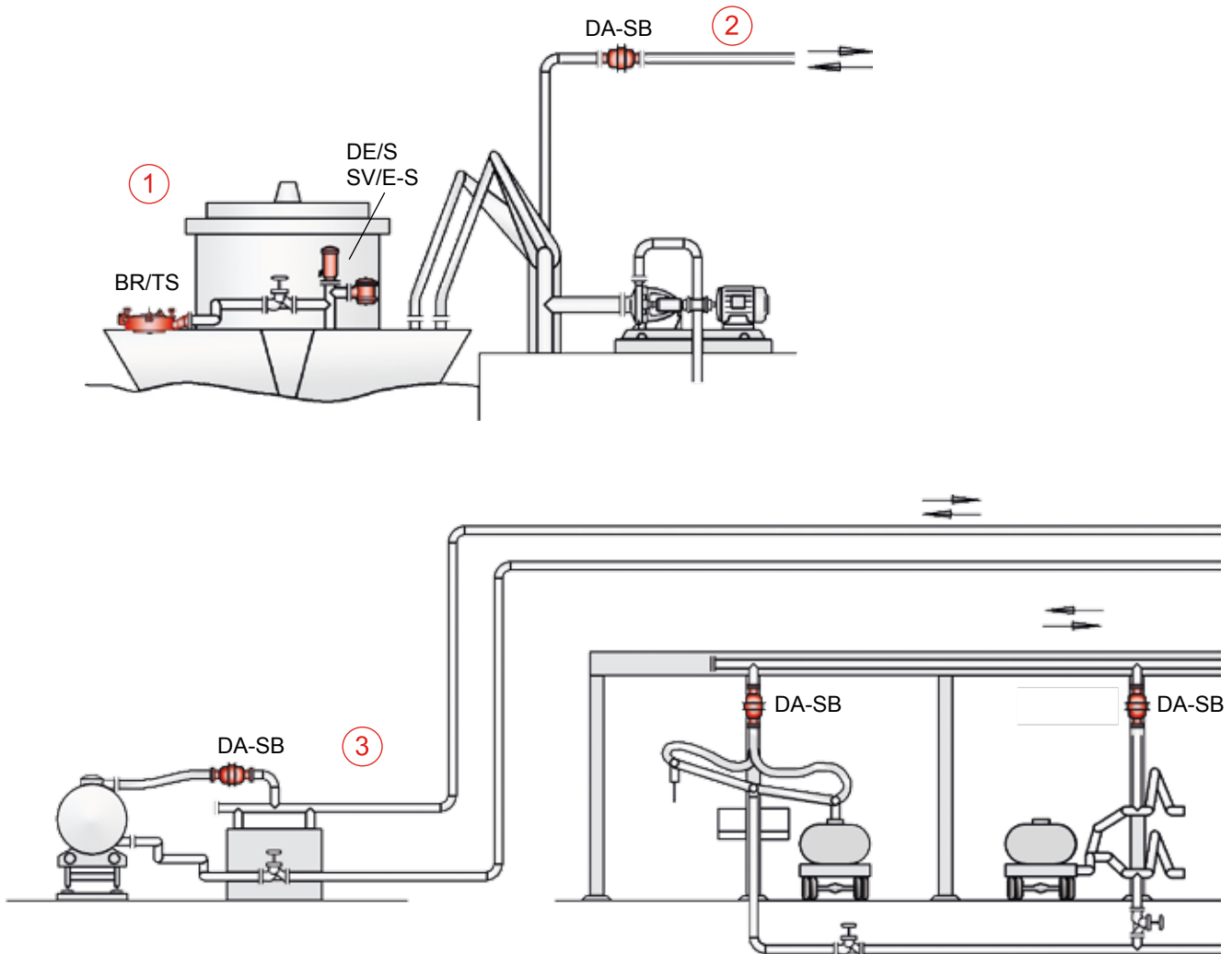

- ① Tank ships for flammable products/chemical tankers with detonation flame arresters BR/TS (→ Volume 4) on the individual tank, endurance-burning-proof high-velocity vent valves DE/S (→ Volume 7), and explosion-proof vacuum flame arrester SV/E-S (→ Volume 7)
- ② Detonation-proof connection of the gas return line at the loading terminal for flammable liquids with a detonation flame arrester DA-SB (→ Volume 4)
- ③ Detonation flame arresters DA-SB (→ Volume 4) in the gas displacement/gas return line from the loading stations for tank waggons and tank trucks

Not shown: Offshore platforms/drilling platforms with detonation flame arresters DA-SB (→ Volume 4) and deflagration flame arresters FA-CN (→ Volume 3), FPSOs (Floating Production Storage and Offloading) with IMO-approved detonation flame arresters DA-SB (→ Volume 4) and pressure and vacuum relief valves VD/TS (→ Volume 7), hydraulic control boxes with deflagration flame arresters BE-AD (→ Volume 2)

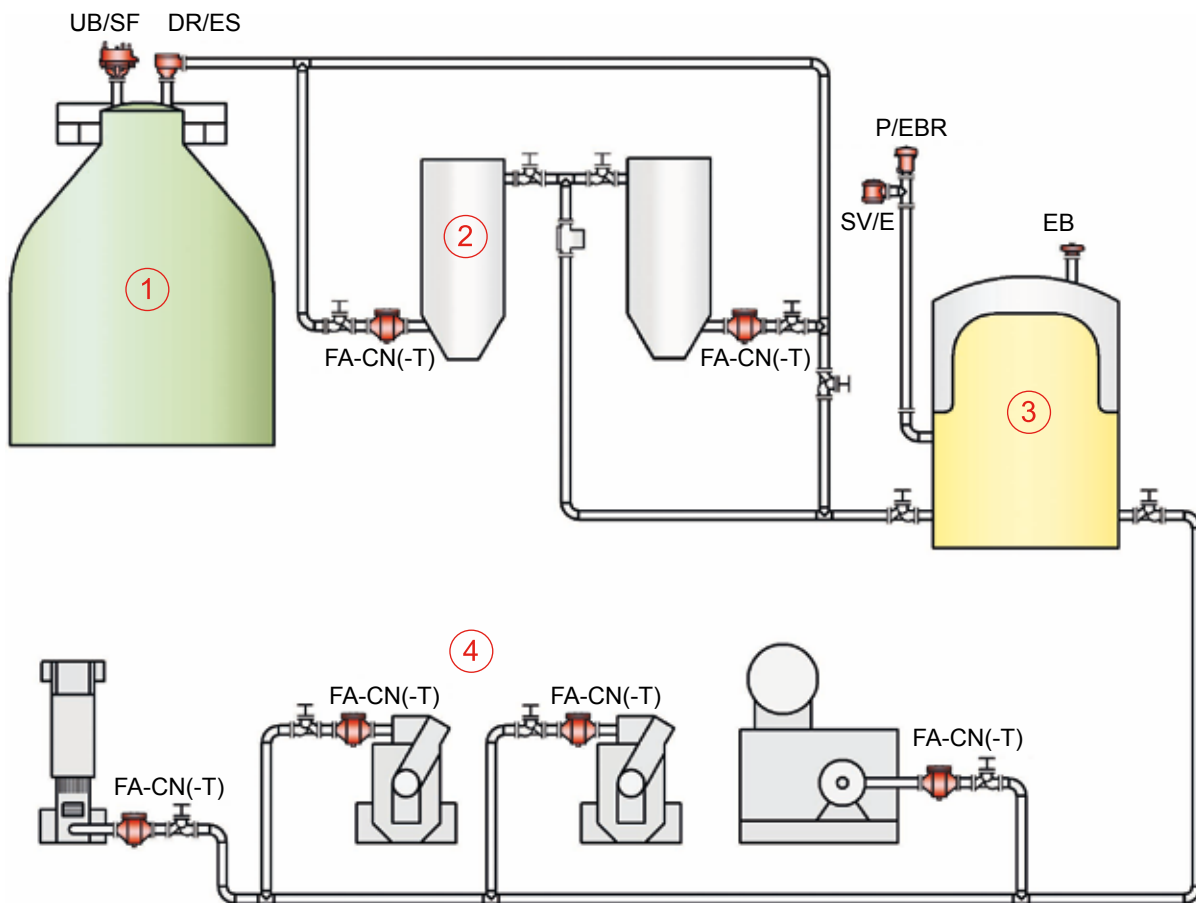

- ① Protecting the sewage tower and storage tank with a frost-proof pressure and vacuum relief valve UB/SF (→ Volume 7) and with detonation flame arresters DR/ES (→ Volume 4) in the gas collection line
- ② Protecting the desulphurization system with deflagration flame arresters suitable for temperature and pressure FA-CN, FA-CN-T alternatively FA-E (→ Volume 3)
- ③ Protecting the intermediate gasholder in the pressure and vacuum relief line with endurance burning proof deflagration flame arrester, end-of-line EB (→ Volume 2), equipping the emergency vent stack with deflagration and endurance burning proof pressure relief valve P/EBR (→ Volume 7) and deflagration proof vacuum relief valve SV/E (→ Volume 7)
- ④ Ground flares, block-type thermal power stations, and diesel engine aggregates are potential sources of ignition for biogas (methane) air mixture. Suitable flame arresters must be installed in the pipe toward the system that consider temperature and pressure. Either temperature-monitored deflagration flame arresters FA-CN-T or FA-E-T (→ Volume 3) or - at a great distance from the potential ignition source - detonation flame arresters DA-SB or DR/ES (→ Volume 4) are used.



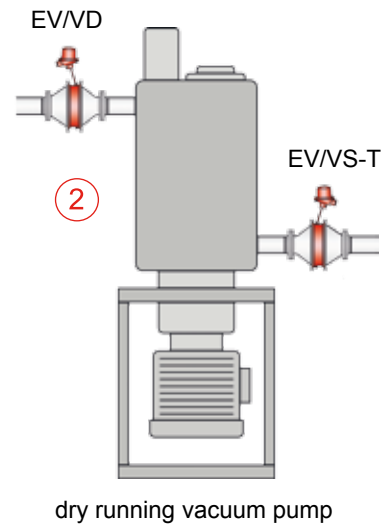
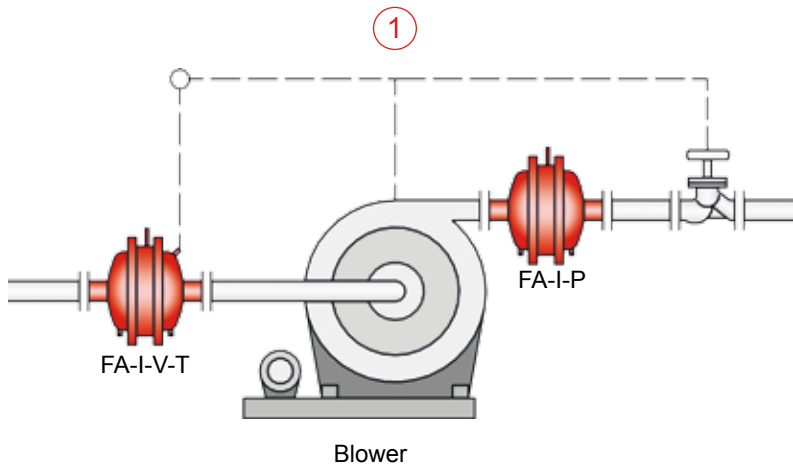

FLAMEFILTER® or PROTEGO® flame arresters as OEM components are product varieties, that are integrated by equipment manufacturers in their brand-name products.

- ① Protecting pressure-resistant radial blowers as type-examined zone-0 blowers with integrated PROTEGO® flame arresters FA-I-V-T and FA-I-P (→ Volume 3)
- ② Protecting dry-running vacuum pumps with PROTEGO® flame arresters EV/VS-T and EV/VD (→ Volume 3) at the inlet and at the outlet, which are tested and certified together with the vacuum pump. Other forms of protection with DR/ES and DR/ES-T (→ Volume 4) are possible.

Not shown: FLAMEFILTER® are used in gas analyzers to protect the explosive environment from explosions arising in the device from the ignition of the gases or vapours to be measured or analyzed. PROTEGO® flame arresters are installed in the pressure and vacuum relief openings of airplane fuel tanks to protect from external explosions.

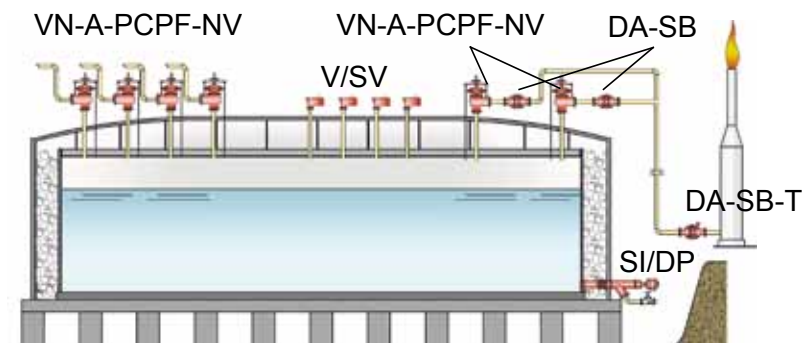

Ammonia Storage Tank

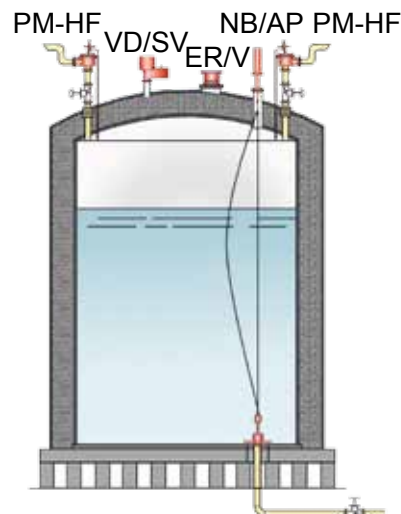

LIN-LOX-LAR Storage Tank

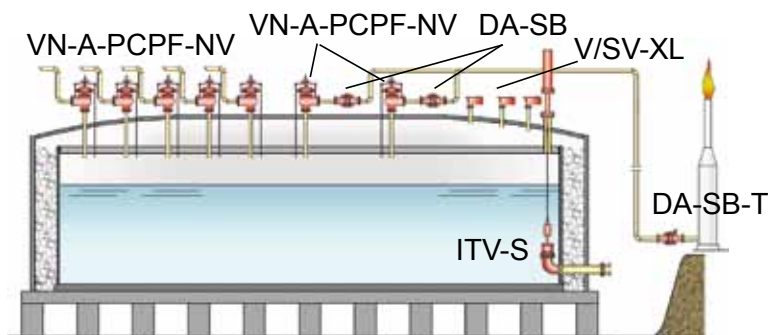

Ethylene Storage Tank

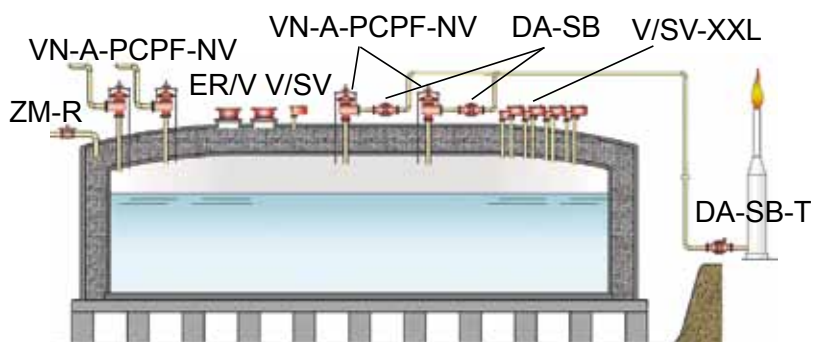

Propylene Storage Tank

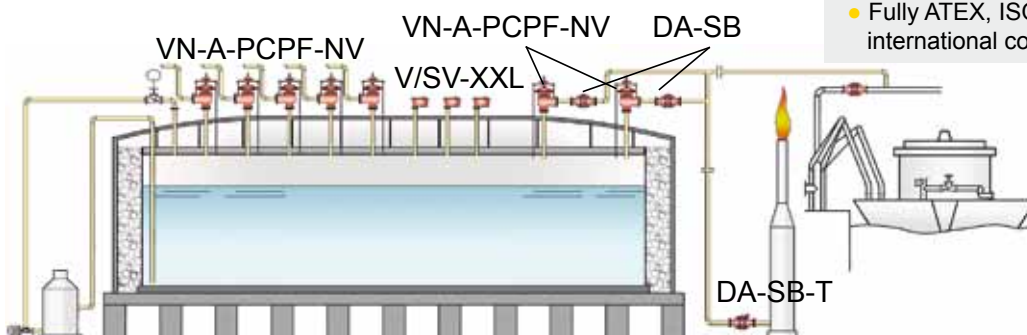

LNG Storage Tank

- Pilot Operated Valves that solve instability problems during operation such as fluttering and chattering.
- Cleaning for oxygen service available on request.
- Cryogenic Functional Test available on request.
- Low Pressure and Vacuum Conservation Vents.
 - Full lift technology available (fully open with only 10% overpressure/pressure accumulation)
 - Deadweight or spring loaded
- Extremely low leakage rates on Breather Valves (much lower than ISO 28300 and API 2000 7th ed.)
- Low Pressure Reducing Valves

- Pneumatic driven fast In-Tank valves.
- Pneumatic and Manual driven Internal Safety Valves.

- ATEX approved Flame Arresters
 - End-of-line applications
 - Deflagration Flame Arresters
 - Endurance burning proof Flame Arresters
 - In-line applications
 - Deflagration Flame Arresters
 - Detonation Flame Arresters

- Sold globally. Serviced locally (PARC).
- Fully ATEX, ISO 9001 and ISO 14001 certified international company.

Products

- VN-A-PCPF-NV, V/SV, ITV-S (→ Volume 9)
- NB/AP, SI/DP, PM-HF (→ Volume 9)
- V/SV-XL, V/SV-XXL (→ Volume 9)
- DA-SB, DA-SB-T (→ Volume 4)
- VD/SV, ER/V (→ Volume 5)
- ZM-R (→ Volume 6)





Flame Arresters

Deflagration Flame Arresters, end-of-line and Vent Caps.....Volume 2



Deflagration flame arresters, deflagration proof, short time burning proof, endurance burning proof
 Vent caps without flame arresters
 Explosion groups: IIA1, IIA, IIB1, IIB2, IIB3, IIB, IIC
 Nominal sizes: 15 to 800 mm (½" to 32")
 Materials: carbon steel, stainless steel, Hastelloy, ECTFE-coated
 Special designs according to customer specifications
 Services and spare parts

Deflagration Flame Arresters.....Volume 3

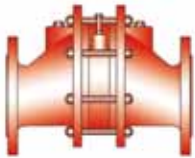

Deflagration flame arresters, in-line, deflagration flame arrester units on equipment
 Explosion groups: IIA1, IIA, IIB1, IIB2, IIB3, IIB, IIC
 Nominal sizes: 10 to 1000 mm (¼" to 40")
 Materials: carbon steel, stainless steel, Hastelloy, ECTFE-coated
 Special designs according to customer specifications
 Services and spare parts

Detonation Flame Arresters.....Volume 4



Detonation flame arresters for stable detonations, for unstable detonations
 Explosion groups: IIA1, IIA, IIB1, IIB2, IIB3, IIB, IIC
 Nominal sizes: 15 to 800 mm (½" to 32")
 Materials: carbon steel, stainless steel, Hastelloy, ECTFE-coated
 Special designs according to customer specifications
 Services and spare parts

Equipment for Cryogenic Storage Tanks

Equipment for Cryogenic Storage Tanks.....Volume 9



Pressure and Vacuum Relief Valves – pilot-operated, Vacuum Relief Valves, Change-Over Valve, In-Tank Valves
 Pressure settings: 10 to 1034 mbar (4 to 413.6 inch W.C.)
 Nominal sizes: 40 (1 ½") to 300 (12")
 Materials: carbon steel, stainless steel, aluminum
 Special designs according to customer specifications
 Services and spare parts

Valves

Pressure and Vacuum Relief Valves, end-of-lineVolume 5



Pressure relief valves, vacuum relief valves, pressure and vacuum relief valves, pressure relief and vacuum valves

Pressure settings: 2 to 200 mbar (0.08 to 8 inch W.C.)

Nominal sizes: 50 to 700 mm (2" to 28")

Materials: carbon steel, stainless steel, Hastelloy, aluminum, PP, PE, PVDF, PTFE, ECTFE-coated

Special designs according to customer specifications

Services and spare parts

Pressure and Vacuum Relief Valves, in-line.....Volume 6



Pressure or vacuum relief valves, pressure and vacuum relief valves, blanketing valves

Pressure settings: 2 to 500 mbar (0.08 to 20 inch W.C.)

Nominal sizes: 25 to 300 mm (1" to 12")

Materials: carbon steel, stainless steel, Hastelloy, PP, PE, PVDF, ECTFE-coated

Special designs according to customer specifications

Services and spare parts

Pressure and Vacuum Relief Valves with Flame Arresters, end-of-line.....Volume 7

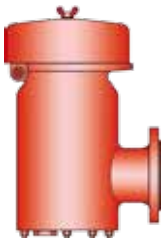

Pressure relief valves, vacuum relief valves, pressure and vacuum relief valves, pressure-/vacuum relief diaphragm valves, pressure relief valves, high velocity valves

Deflagration-proof and endurance-burning-proof or deflagration-proof only

Explosion groups: IIA1, IIA, IIB1, IIB2, IIB3, IIB, IIC

Pressure settings: 2 to 200 mbar (0.08 to 8 inch W.C.)

Nominal sizes: 50 to 300 mm (2" to 12")

Materials: carbon steel, stainless steel, Hastelloy, ECTFE-coated

Special designs according to customer specifications

Services and spare parts

Tank Accessories and Special Equipment



Level-gauging and sampling equipment.....Volume 8

Floating suction unit, floating-roof drainage system

Floating-roof vacuum relief valves, skimming system

Air-drying aggregates, sampling and draining valves

Services and spare parts



for safety and environment



Regulations and Laws

2014/34/EU Directive of the European Parliament and the Council of February 21, 2014 on the approximation of the laws of the Member States concerning equipment and Protective Systems intended for use in potentially explosive atmospheres (recast, replace 94/9/EC after April, 20 2016)

94/9/EC Directive of the European Parliament and the Council of March 23, 1994 on the approximation of the laws of the Member States concerning equipment and Protective Systems intended for use in potentially explosive atmospheres (replaced by 2014/34/EU)

1999/92/EC Directive of the Council on minimum requirements for improving the safety and health of workers potentially at risk from explosive atmospheres (individual directive according to article 16 of Directive 89/391/EEC)

2006/42/EC Directive on machinery of 17 May 2006

2014/68/EU (PED) Pressure equipment directive of the European Parliament and the European Council replace 97/23/EC from 17.7.2015 shall applied from July 19, 2016

97/23/EC Pressure equipment directive of the European Parliament and the European Council valid until July 18, 2016

1999/13/EC Control of VOC emissions resulting from storage and distribution of petrol

Standards

EN ISO 28300: Petroleum, petrochemical and natural gas industries - Venting of atmospheric and low-pressure storage tanks, 2008

EN ISO 16852: Flame Arresters - Performance requirements, test methods and limits for use, 2016

EN 12874 Flame Arresters: Performance Requirements, Test Methods, and Limits for Use, 2001

EN 1127-1 Explosive Atmospheres. Explosion Prevention and Protection. Part 1: Basic Concepts and Methodology, 2011

EN 1012-2 Compressors and Vacuum Pumps. Part 2: Vacuum pumps, 2011

EN 12255-10 Wastewater Treatment Plants - Part 10: Safety and Construction Principles, 2001

EN 13463-1 Non-Electrical Equipment Intended For Use in Potentially Explosive Atmospheres - Part 1: Basic Methods and Requirements, 2009

EN 13463-5 Non-electrical equipment intended for use in potentially explosive atmospheres - Part 5: Protection by constructional safety 'c', 2012

EN ISO/IEC 80079-34 Explosive atmospheres - Part 34: Application of quality systems for equipment manufacture, 2012

EN 14015 Specification for the Design and Manufacture of Site-Built, Above-Ground, Vertical, Cylindrical, and Welded Flat-Bottomed, Steel Tanks for the Storage of Liquids at Ambient Temperature and Above, Appendix L: Requirements for Pressure and Vacuum Relief Systems, 2005

33 CFR Part Facilities Transferring Oil Or Hazardous Material in Bulk (USCG-Rule)

API STD 2000 7th ed. Venting Atmospheric and Low-Pressure Storage Tanks, 2014

API Publ 2210 3rd ed. Flame Arresters for Vents of Tanks Storing Petroleum Products, 2000 (in revision)

API Publ 2028 2nd ed. Flame Arresters in Piping, 1991

API Bulletin 2521, Use of Pressure-Vacuum Vent Valves for Atmospheric Pressure Tanks to Reduce Evaporation Loss, 1993

ANSI/UL 525 6th ed. Standard for Flame Arresters, 1994

ASTM F1273-91 Standard Specification for Tank Vent Flame Arresters, Reapproved 2007

NFPA 30 Flammable and Combustible Liquids Code, 2015 ed.

NFPA 36 Standard for Solvent Extraction Plants, 2017 ed.

NFPA 59A Standard for the Production, Storage, and Handling of Liquefied Natural Gas (LNG), 2016 ed.

NFPA 67 Guide on Explosion Protection for Gaseous Mixtures in Pipe Systems, 2016 ed.

NFPA 68, Venting of Deflagrations, 2013 ed.

NFPA 69 Standard on Explosion Prevention Systems, 2014 ed.

NFPA 497 Recommended Practice for the Classification of Flammable Vapors and of Hazardous Locations for Electrical Installations in Chemical Process Areas, 2017 ed.

HSG176 The Storage of Flammable Liquids in Tanks, 2015

IEC 60079-10-1 Explosive atmospheres. Classification of areas. Explosive gas atmospheres, 2016

EN 60079-20-1 Explosive atmospheres - Part 20-1: Material characteristics for gas and vapour classification - Test methods and data (IEC 60079-20-1), 2010

PD CEN/TR 16793:2016 Guide for the selection, application and use of flame arresters

EN ISO 80079-36: 2016 Explosive atmospheres - Part 36: Non-electrical equipment for explosive atmospheres - Basic method and requirements (ISO 80079-36:2016)

EN ISO 80079-37:2016 Explosive atmospheres - Part 37: Non-electrical type of protection constructional safety „c“, control of ignition sources „b“, liquid immersion „k“ (ISO 80079-37: 2016) (Endorsed by AENOR in September of 2016)

Technical Regulations

Occupational Safety and Health Protection Rules - Explosion Protection Rules (EX-RL), 2015 - German

TRBS 2152 Hazardous explosive atmosphere, 2016

TRBS 3151 Vermeidung von Brand-, Explosions- und Druckgefährdungen an Tankstellen und Füllanlagen zur Befüllung von Landfahrzeugen, 2015

TRbF 20 Lager, 2002

VdTÜV-Merkblatt Tankanlagen 967, 2012

VDI 3479, Emission Reduction, Distribution Storage for Mineral Oil Far from Refineries, 2010

GUV-R 127 Regeln für Sicherheit und Gesundheitsschutz, Deponien, 2001

AO 8.06/77 Explosion Protection in the Manufacture and Processing of Fermented Spirits (Alcohol Memorandum), Institution for Statutory Accident Insurance and Prevention in the Food Industry and the Catering Trade - German

TRGS 509 Lagern von flüssigen und festen Gefahrstoffen in ortsfesten Behältern sowie Füll- und Entleerstellen für ortsbewegliche Behälter 2014 - German

Technical Literature (Selection)

Handbook of Explosion Prevention and Protection (Editor: Steen, H.) Wiley-VCH Verlag, Weinheim (2008)

Lexikon Explosionsschutz, Sammlung definierter Begriffe, Berthold Dyrba, Carl Heymanns Verlag (2006)

6. Nachtrag zu Sicherheitstechnischen Kennzahlen brennbarer Gase und Dämpfe (K. Nabert, G. Schön), Deutscher Eichverlag GmbH, Braunschweig 1990

Brandes, E., Möller W. Safety Characteristic Data Volume 1: Flammable Liquids and Gases, Schünemann Verlag, 2008

Schampel K.: Flammendurchschlagsicherungen, Expert Verlag, 1988

Brandes, E., März, G., Redeker, T., Normspaltweiten von Mehr-Brennstoffkomponenten-Gemischen in Abhängigkeit der Brennstoffzusammensetzung, PTB-Bericht PTB-W-69, Juni 1997

Steen, H., Schampel, K.: Stoffabhängigkeit der Wirkung flammendurchschlagsicherer Einrichtungen. Fortschritt-Berichte VDI, Reihe 6, Nr. 122 1983

Schampel, K.: Verhinderung eines Dauerbrandes an Flammendurchschlagsicherungen in Lüftungsleitungen von Behältern und Apparaturen, 2. Sicherheitstechnische Vortragsveranstaltung über Fragen des Explosionsschutzes, PTB-Bericht W-20 (1983) 20-29.

Bartknecht, W.: Explosionsschutz, Grundlagen und Anwendungen, Springer Verlag, Berlin, Heidelberg, 1993

Prof. Dr. Hans Witt, Explosionsschutz bei Ventilatoren, Witt & Sohn GmbH&Co., Pinneberg, 1998

Meidinger, Ventilatoren zur Förderung von Gas/Luft- oder Dampf/Luftgemischen der Zone 0, 1998

Eberhard Grabs, Anforderungen an explosionsgeschützte Vakuumpumpen - Ergebnisse einer Risikobewertung - Veröff. in PTB Mitteilungen 106 5/96

U. Füssel, Vakuum ohne Abwässer - Trockenläufer setzen sich durch, Chemie Technik, 1998

U. Friedrichsen, Konzept erfolgreich getestet - Trockenlaufende Vakuumpumpe sichert wirtschaftlichen Prozess, Chemie Technik, 1998

Bjerketvedt, D., Bakke, J.R., van Wingerden, K.: Gas Explosion Handbook, Journal of Hazardous Materials 52 (1997), 1 – 150

Redeker, T.: Sicherheitstechnische Kennzahlen – Basis für den Explosionsschutz, 9. Internationales Kolloquium für die Verhütung von Arbeitsunfällen und Berufskrankheiten in der chemischen Industrie Luzern, 1984

Stanley S. Gossel: Deflagration und Detonation Flame Arresters, 2002

PROTEGO® Publications

Absicherung der Abblaseleitung eines Sicherheitsventils durch eine Deflagrationsendsicherung; Dr. T. Heidermann/H. Kuchta; Technische Überwachung, 2003

In-line Flame Arresters to Prevent Flashback of Thermal Combustion Units; Dr. T. Heidermann/Dr. M. Davies; Wiley InterScience, 2006

Keeping explosion in isolation; Dr. T. Heidermann/Dr. M. Davies/Dr. P. Bosse; HYDROCARBON ENGINEERING, 2008

A Research Study on Safe Application of Flame Arresters for Thermal Combustion Units; Dr. M. Davies/Dr. T. Heidermann/D.Long; HYDROCARBON ENGINEERING, 2008

FLAME ARRESTERS FOR PLANTS HANDLING ACETYLENE AND ETHYLENE OXIDE; D. Long/Dr. T. Heidermann; IChemE, 2009

Leben schützen, Werte erhalten; Hochgeschwindigkeitsventile in der Edelmetallverarbeitung; Dr. T. Heidermann; Verfahrenstechnik, 2009

Flames under arrest; Dr. M. Davies/Dr. T. Heidermann; HYDROCARBON ENGINEERING, 2012

FLAME ARRESTERS; Testing and applying flame arresters; Dr. M. Davies/Dr. T. Heidermann; INDUSTRIALFIRE JOURNAL, 2011

Conservation vents do not substitute arresters; Dr. M. Davies/Dr. T. Heidermann; Tank Storage Magazine, 2010

New standards for flame arresters and tank venting; Dr. T. Heidermann; 13th International Symposium on Loss Prevention

FLAME TRANSMISSION TESTS WITH P/V VALVES; Dr. M. Davies/Dr. T. Heidermann; Test Report, 2007

FLAME ARRESTERS; Dr. M. Davies/Dr. T. Heidermann; Perry's chemical engineers Handbook 8th EDITION Green Perry; 23-92

CFD-Modeling for Optimizing the Function of Low-Pressure Valves; F. Helmsen, T. Kirchner; Process and Plant Safety; 2012 Wiley-VCH Verlag GmbH & Co. KGaA

Sicherheit bei Problemprodukten; Dr. M. Davies/Dr. P. Bosse/ T. Klocke; POWTECH, TECHNOPHARM, EXPLORISK

New ISO standard for flame arresters to increase explosion isolation efficiency; Dr. M. Davies/Dr. T. Heidermann/Dr. P. Bosse; HYDROCARBON ENGINEERING

No safe substitute, FLAME ARRESTERS; HAZARDOUS CARGO BULLETIN, 2008

Schwerpunkt: Lagerung: Flammen filtern; T. Schaper/Dr. P. Bosse; Gefährliche Ladung, 2005

A conservation vents is not a safe substitute for a flame arrester; Dr. T. Heidermann/Dr. M. Davies/D. Preusse; HYDROCARBON ENGINEERING, 2008

Venting Technologies for reducing vapour losses; Dr. P. Bosse/Dr. M. Davies; HYDROCARBON ENGINEERING, 2008

Auslegung, sicherer Betrieb und Instandhaltung von Schutzsystemen in explosionsgefährdeten überwachungsbedürftigen Anlagen; Dr. V. Halstrick; Technische Sicherheit, 2012

Protect Your Process With The Proper Flame Arresters. Dr. M. Davies, Dr. T. Heidermann, CEP, 2013

Alt neben Neu - Konzept für qualifizierte und regelmäßigeWartung; T. Anderssohn; Verfahrenstechnik, 2012

Flammendurchschlagsicherungen - Planung, Betrieb, Wartung; T. Anderssohn; Industriearmaturen, 2013R. Raman, D. Moncalvo, T. Heidermann, S. Kostos; Overfilling Protection for Weak Tanks, CCPS 2015

Influence of Overpressure in Pressure Vacuum Safety Valves on Emission Reduction and Explosion Risk Minimization of Atmospheric Storage Tanks; 11th Global Congress of Process Safety; Dr.-Ing. Davide Moncalvo, Dr.-Ing. Michael Davies, 2015

Overfilling Protection for Weak Tanks, 11th Global Congress of Process Safety; Rahul Raman, Justin Phillips, 2015

"Breathing losses from low-pressure storage tanks due to atmospheric weather change"; Dr. D. Moncalvo, Dr. M. Davies, R. Weber, R. Stolz; Journal of Loss Prevention in the Process Industries 43, 2016

"Testing and applying flame arresters to prevent large terminal fires"; Dr. M. Davies, D. Long; Tank Storage Magazine, 2017

"Explosionsschutz auf Binnentankschiffen"; Dr. T. Heidermann; Binnenschiffahrt, 2017

„Storage Instability“ Dr Davies Michael, Dr Moncalvo Davide, Thorsten Schaper, Braunschweiger Flammenfilter GmbH, discuss how to solve pilot valve instability on cryogenic storage tanks.



Appendix

Glossary

Term	Description	Source
accumulation	pressure increase over the maximum allowable working pressure of the vessel allowed during discharge through the pressure-relief device	ISO 23251 - 3.1
actual flow capacity	actual flow capacity is the flowing capacity determined by measurement	DIN 3320-75
adjusted set pressure	vacuum or gauge pressure at which under test stand conditions (atmospheric back pressure) valves commence to lift	-
ambient air	normal atmosphere surrounding the equipment and protection system	EN 13237 - 3.1
ambient temperature	temperature of the air or other medium where the equipment is to be used (IEV 826-01-04) (IEC 60204-32:1998) Note: For the application of the Directive 94/9/EC only air is considered	EN 13237 - 3.2
annular flame arresting unit	flame arresting unit consisting of annular crimped ribbons	-
atmospheric conditions	atmospheric conditions are pressures from 80 kPa till 110 kPa and temperatures from -20°C up to +60°C	ISO 16852 - 3.25
atmospheric discharge	release of vapors and gases from pressure-relieving and depressurizing devices to the atmosphere	ISO 23251 - 3.4
back pressure	the back pressure is the gauge pressure existing at the outlet side during blowing ($p_a = p_{ae} + p_{af}$)	DIN 3320-58
bi-directional flame arrester	a flame arrester which prevents flame transmission from both sides	ISO 16852 - 3.13
blow down	difference between set pressure and reseating pressures, normally stated as a percentage of set pressure	-
bottom drain valve	emergency valve at the tank bottom to shut immediately in case of downstream piping rupture	-
check valve	valve, that prevents backflow against flow direction	-
coating	protective painting with defined layer-thickness	
combustion air	air required to combust the flare gases	ISO 23251 - 3.19
component	„component“ means any item essential to the safe functioning of Equipment and Protective System but with no autonomous function	EN 1127 - 3.2
condensate drain screw	screw to drain the condensate	-
conventional pressure-relief valve	spring-loaded pressure-relief valve whose operational characteristics are directly affected by changes in the back pressure	ISO 23251 - 3.20
deflagration	explosion propagating at subsonic velocity (EN 1127-1:1997)	EN 13237 - 3.15
deflagration flame arrester	flame arrester designed to prevent the transmission of a deflagration. It can be an end-of-line flame arrester or an in-line flame arrester	ISO 16852 - 3.14
design pressure (tank)	max. permissible pressure of a tank in the space above the stored liquid	-

design pressure / design temperature (general design)	pressure, together with the design temperature, used to determine the minimum permissible thickness or physical characteristic of each component, as determined by the design rules of the pressure-design code	ISO 23251 - 3.23
design vacuum (negative gauge pressure)	max. permissible vacuum (negative gauge pressure) in the space above the stored liquid	-
detonation	explosion propagating at supersonic velocity and characterized by a shock wave (EN 1127-1: 1997)	EN 13237 - 3.18
detonation flame arrester	flame arrester designed to prevent the transmission of a detonation. It can be an end-of-line flame arrester or an in-line flame arrester	ISO 16852 3.15
detonation proof by-pass	dry-type detonation proof by-pass to keep a minimum liquid for safety reasons	-
diaphragm valve	valve, where the moving valve part consists of a diaphragm	-
emergency venting	venting required when an abnormal condition, such as ruptured internal heating coils or an external fire, exists either inside or outside a tank	ISO 28300 - 3.23
emergency venting valves	pressure relief valves for emergency venting	-
end-of-line flame arrester	flame arrester that is fitted with one pipe connection only	ISO 16852 - 3.23
endurance burning	stabilized burning for an unlimited time	ISO 16852 - 3.6
endurance burning flame arrester	flame arrester that prevents flame transmission during and after endurance burning	ISO 16852 - 3.16
equipment	„equipment“ means machines, apparatus, fixed or mobile devices, control components and instrumentation thereof and detection and prevention systems which, separately or jointly, are intended for the generation, transfer, storage, measurement, control and conversion of energy, for the processing of material, and which are capable of causing an explosion through their own potential sources of ignition	EN 1127 - 3.5
equipment category	within an equipment group, a category is the classification according to the required level of protection. The categories are defined as given in A.6.	EN 13237 - 3.26
explosion	abrupt oxidation or decomposition reaction producing an increase in temperature, pressure or in both simultaneously	ISO 16852 - 3.7
explosion limits	limits of explosion range (EN 1127-1:1997)	EN 13237 - 3.29
explosive atmosphere	mixture with air, under atmospheric conditions, of flammable substances in the form of gases, vapors, mists or dusts, in which, after ignition has occurred, combustion spreads to the entire unburned mixture	EN 1127 - 3.17
flame arrester	a device fitted to the opening of an enclosure or to the connecting pipework of a system of enclosures and whose intended function is to allow flow but prevent the transmission of flame	ISO 16852 - 3.1
flame arrester cage	enclosure for the flame arrester element including spider rings	-
flame arrester element	crimped ribbon element	-



Appendix

Glossary

flame arrester element gap	flame arrester elements have profiles, which are more or less triangular. The flame arrester element gap is the triangular height of the flame arrester element	-
flame arrester housing	that portion of a flame arrester whose principal function is to provide a suitable enclosure for the flame arrester element and allow mechanical connections to other systems	ISO 16852 - 3.2
flame arrester set	combination of flame arrester elements with spacers	-
flame arrester unit	flame arrester cage with flame arrester elements and spacers	-
flame transmission proof	characteristic of a device to avoid flashback	-
FLAMEFILTER®	international trademarks by Braunschweiger Flammenfilter GmbH for flame arrester element made of crimped ribbon	-
FLAMEFILTER® cage	enclosure for FLAMEFILTER® including spider rings	-
FLAMEFILTER® gap	flame arrester element gap of a crimped ribbon element type FLAMEFILTER®	-
FLAMEFILTER® set	combination of FLAMEFILTER® with spacers	-
flammable gas or vapor	gas or vapor which, when mixed with air in certain proportions, will form an explosive gas atmosphere (EN 60079-10:1996)	EN 13237 - 3.44
flammable liquid	liquid capable of producing a flammable vapor under any foreseeable operating condition (EN 60079-10:1996)	EN 13237 - 3.45
flammable material	material which is flammable of itself, or is capable of producing a flammable gas, vapor or mist (EN 60079-10:1996)	EN 13237 - 3.46
flammable substances	substance in the form of gas, vapor, liquid, solid, or mixtures of these, able to undergo an exothermic reaction with air when ignited (EN 1127-1:1997)	EN 13237 - 3.48
flashback	phenomenon occurring in a flammable mixture of air and gas when the local velocity of the combustible mixture becomes less than the flame velocity, causing the flame to travel back to the point of mixture	ISO 23251 - 3.34
flashpoint	lowest temperature, corrected to a barometric pressure of 101,3 kPa, at which application of a test flame causes the vapor of the test portion to ignite under the specified conditions of test (ISO 13736:1997)	EN 13237 - 3.49
floating cover	structure which floats on the surface of a liquid inside a fixed roof tank, primarily to reduce vapor loss	EN 14015 - 3.1.22
floating roof	metallic structure which floats on the surface of a liquid inside an open top tank shell, and in complete contact with this surface	EN 14015 - 3.1.21
floating suction unit	mechanical device, sometimes articulated, installed in some tanks, which floats on the liquid surface and only permits product to be withdrawn from this point	EN 14015 - 3.1.28
foot valve flame arrester	a flame arrester designed to use the liquid product combined with a non return valve to form a barrier to flame transmission	ISO 16852 - 3.19.2
free vents	open vents	EN 14015 - 3.1.40

fusible link	component which melts at a defined temperature and which actuates another function (opening of hood, closing of valve)	-
gauging and sampling device	equipment for stating the liquid level within storage tanks as well as for sampling from any height within the stored medium	-
gauging nozzle	opening at a storage tank for gauging or sampling	-
gauging pipe	pipe within the storage tank for determining the liquid level and for sampling - in flashback-proof or regular design	-
gauging probe	device for determining the liquid levels in storage tanks	-
guide bushing	component for guiding e.g. the guide spindle of a valve pallet	-
guide rod	component (rod) for guidance of valve pallet	-
guide spindle	orthogonal to valve pallet section, central pipe for guiding the valve pallet	-
guide pipe	pipe for guiding the guide spindle of a valve pallet	-
hazardous area	area in which an explosive atmosphere is present, or may be expected to be present in quantities such as to require special precautions for the construction, installation and use of equipment	EN 13237 - 3.55
hazardous explosive atmosphere	explosive atmosphere which, if it explodes, causes damage	EN 1127 - 3.19
heat release	total heat liberated by combustion of the relief gases based on the lower heating value	ISO 23251 - 3.36
heating jacket	closed room for heating of a device, which encloses the device fully or partly	-
high velocity vent valve (dynamic flame arrester)	pressure relief valve designed to have nominal flow velocities that exceed the flame velocity of the explosive mixture, thus preventing flame transmission	ISO 16852 - 3.18
housing	enclosure of a product or component	-
hydraulic flame arrester	flame arrester designed to break the flow of an explosive mixture into discrete bubbles in a water column, thus preventing flame transmission	ISO 16852 - 3.20
ignition source	any source with sufficient energy to initiate combustion (EN ISO 13702:1999)	EN 13237 - 3.62
ignition temperature (of a combustible gas or of a combustible liquid)	the lowest temperature of a heated wall as determined under specified test conditions, at which the ignition of a combustible substance in the form of gas or vapor mixture with air will occur	EN 1127 - 3.31
inert gas	non-flammable gas which will not support combustion and does not react to produce a flammable gas	EN 13237 - 3.68
inerting	addition of inert substances to prevent explosive atmospheres	EN 1127 - 3.21
in-line flame arrester	flame arrester that is fitted with two pipe connections, one each side of the flame arrester	ISO 16852 - 3.22
integrated temperature sensor	temperature sensor integrated into the flame arrester, as specified by the manufacturer of the flame arrester, in order to provide a signal suitable to activate counter measures	ISO 16852 - 3.24



Appendix

Glossary

leak rate	leakage of a device in volume per time (liter per second)	-
left-hand wound	orientation (angle) of gaps of crimped ribbon element	-
lift	actual travel of the valve disc away from the closed position	ISO 4126 - 3.3
limiting oxygen concentration (LOC)	maximum oxygen concentration in a mixture of a flammable substance and air and an inert gas, in which an explosion will not occur, determined under specified test conditions (EN 1127-1:1997)	EN 13237 - 3.64
lining	protective cladding with defined minimum/maximum thickness to protect against aggressive mixtures (e.g. acid)	-
liquid product detonation flame arrester	flame arrester in which the liquid product is used to form a liquid seal as a flame arrester medium, in order to prevent flame transmission of a detonation. There are two types of liquid product detonation flame arrester for use in liquid product lines: liquid seals and foot valves	ISO 16852 - 3.19
liquid seal (water seal)	device that directs the flow of relief gases through a liquid (normally water) on the path to the flare burner, used to protect the flare header from air infiltration or flashback, to divert flow, or to create back pressure for the flare header	ISO 23251-3.43
lower explosion limit (LEL)	the lower limit of the explosion range	EN 1127 - 3.8
maintenance	combination of all technical and administrative actions, including supervision actions, intended to retain an item in, or restore it to, a state in which it can perform a required function	EN 13237 - 3.78
malfunction	the equipment, protective system and components do not perform the intended function	EN 1127 - 3.25
manifold	pipng system for the collection and/or distribution of a fluid to or from multiple flow paths	ISO 23251 - 3.45
maximum allowable explosion pressure	calculated maximum explosion pressure which the equipment will withstand	EN 14460 - 3.7
maximum allowable pressure (pressure equipment)	maximum pressure for which the equipment is designed as specified by the manufacturer	97/23/EC (PED)
maximum allowable temperature (pressure equipment)	maximum temperature for which the equipment is designed as specified by the manufacturer	97/23/EC (PED)
maximum allowable working pressure (MAWP)	maximum gauge pressure permissible at the top of a completed vessel in its normal operating position at the designated coincident temperature specified for that pressure	ISO 23251 - 3.47
maximum experimental safe gap (MESG)	the maximum gap of the joint between the two parts of the interior chamber of the test apparatus which, when the internal gas mixture is ignited and under specified conditions, prevents ignition of the external gas mixture through a 25 mm long joint, for all concentrations of the tested gas or vapor in air. The MESG is a property of the respective gas mixture (EN 1127-1: 1997) Note: IEC 60079-1 A standardizes the test apparatus and the test method	-
maximum operating temperature	maximum temperature reached when equipment or protective system is operating at its intended operating conditions	-

measurable type (static flame arrester)	a flame arrester where the quenching gaps of the flame arrester element can be technically drawn, measured and controlled	ISO 16852 - 3.17.1
most easily ignitable explosive atmosphere	explosive atmosphere with a concentration of flammable substances which under specified conditions, requires the lowest energy for its ignition	EN 13237 - 3.87
nominal size, nominal diameter	(DN) a numerical size designation used for all components of a piping system, for which the external diameter or the size of thread is not indicated. The figure is rounded and has only an approximate relation to the machined dimensions	-
non-measurable type (static flame arrester)	a flame arrester where the quenching gaps of the flame arrester element cannot be technically drawn, measured or controlled (e.g. random such knitted mesh, sintered metal and gravel beds)	ISO 16852 - 3.17.2
normal pressure venting	outbreathing under normal operating conditions (pumping product into the tank and thermal outbreathing)	EN 14015 - 3.1.35
normal vacuum venting	inbreathing under normal operating conditions (pumping product out of the tank and thermal inbreathing)	EN 14015 - 3.1.36
normal venting	venting required because of operational requirements or atmospheric changes	ISO 28300 – 3.7
opening pressure	the opening pressure is the vacuum resp. gauge pressure at which the lift is sufficient to discharge the predetermined mass flow; it is equal to the set pressure plus overpressure	DIN 3320 - 54
operating pressure	pressure in the process system experiences during normal operation, including normal variations	ISO 23251 - 3.49
operating temperature	temperature reached when the apparatus is operating at its rating	-
overpressure	pressure increase over the set pressure, at which the safety valve attains the lift specified by the manufacturer, usually expressed as a percentage of the set pressure	ISO 4126 - 3.2.3
pallet guidance	element of valve providing guidance of valve pallet	-
pallet type valve (disc valve)	valve with discoidal seal and axial guide	-
pilot-operated pressure relief valve	pressure relief valve in which the major relieving device or main valve is combined with and controlled by a self-actuated auxiliary pressure-relief valve (pilot)	ISO 23251 - 3.52
pilot-operated valve	valve actuated by a control device (pilot)	-
pipe away valve	pressure or vacuum valve to which a vent pipe may be connected	EN 14015 - 3.1.44
pressure	pressure unit used in this standard is the bar (1 bar = 10000 Pa), quoted as gauge (relative to atmospheric pressure) or absolute as appropriate	ISO 4126 - 3.2
pressure-relief valve	valve designed to open and relieve excess pressure and to reclose and prevent the further flow of fluid after normal conditions have been restored	ISO 23251 - 3.56
pressure/vacuum valve (PV valve)	weight-loaded, pilot-operated, or spring-loaded valve, used to relieve excess pressure and/or vacuum that has developed in a tank	ISO 23251 - 3.11



Appendix

Glossary

pre-volume flame arrester	flame arrester that, after ignition by an internal ignition source, prevents flame transmission from inside an explosion-pressure-resistant containment (e.g. a vessel or closed pipe work) to the outside, or into the connecting pipe work	ISO 16852 - 3.23
product	term product covers equipment, protective systems, devices, components and their combinations as well as software as defined in 3.4.2 of EN ISO 9000:2000 (EN 13980.2002)	EN 13237 - 3.95
protective screen	component, which provides free flow, but prevents entrance of foreign matter, for example animals	-
protective system	„protective system“ means design units which are intended to halt incipient explosions immediately and/or to limit the effective range of explosion flames and explosion pressures. Protective systems may be integrated into equipment or separately placed on the market for use as autonomous systems	EN 1127 - 3.36
quenching	cooling of a fluid by mixing it with another fluid of a lower temperature	ISO 23251 - 3.59
relieving pressure	pressure at the inlet of a relief device when the fluid is flowing at the required relieving capacity	ISO 28300 - 3.15
reseating pressure (closing pressure)	value of the inlet static pressure at which the disc re-establishes contact with the seat or at which the lift becomes zero	ISO 4126 - 3.2.4
right-hand wound	orientation (angle) of gaps of crimped ribbon element	-
safety shut-off valve	a safety shut-off valve is a valve which closes automatically to prevent a predetermined gauge pressure being exceeded	DIN 3320-2
safety valve	valve which automatically, without the assistance of any energy other than that of the fluid concerned, discharges a quantity of the fluid so as to prevent further flow of fluid after normal pressure conditions of service have been restored	ISO 4126 - 3.1
sampling and air bleed valve	flashbackproof and non flashbackproof taps or valves out- and inbreathing of parts of plant	-
set pressure	gauge pressure at the device inlet at which the relief device is set to start opening under service conditions	ISO 28300 - 3.19
set vacuum	internal negative gauge pressure at which a vacuum valve first opens	-
shock absorber	component to reduce the kinetic energy of a detonation	-
Shock-Wave-Guide-Tube (SWG T)	component for decoupling of shock wave and flame front: PROTEGO® patent	-
short time burning	stabilized burning for a specific time	ISO 16852 - 3.5
spacer	component, which lies on and between the crimped ribbon elements of a flame arrester unit	-
sparge pipe	pipe leading into the dip liquid of an hydraulic flame arrester	-
stabilized burning	steady burning of a flame stabilized at, or close to the flame arrester element	ISO 16852 - 3.4
stable detonation	a detonation is stable when it progresses through a confined system without significant variation of velocity and pressure characteristics	ISO 16852 - 3.10

static electricity	build-up of an electrical difference of potential or charge, through friction of dissimilar materials or substances e.g. product flow through a pipe	EN 14015 - 3.1.18
static flame arrester	a flame arrester designed to prevent flame transmission by quenching gaps	ISO 16852 - 3.17
stoichiometric air	chemically correct ratio of fuel to air capable of perfect combustion with no infused fuel or air	ISO 23251 - 3.73
storage tank storage vessel	fixed tank or vessel that is not part of the processing unit in petrochemical facilities, refineries, gas plants, oil and gas production facilities, and other facilities	ISO 23251 - 3.74
swing pipe unit	flexible pipeline with or without float within a storage tank for filling and emptying	-
swivel joint	part of a swing pipe system	-
temperature class	classification of equipment, protective system or component for explosive atmospheres based on its maximum surface temperature	EN 13237 - 3.111
temperature sensor	temperature sensor for monitoring the temperature	-
test pressure	pressure to test the mechanical stability of devices and or to test devices for leak	-
thermal inbreathing	movement of air or blanketing gas into a tank, when vapours in the tank contract or condense as a result of weather changes (e.g. decrease in atmospheric temperature)	ISO 28300 - 3.20
thermal outbreathing	movement of air or blanketing gas out of a tank, when vapours in the tank expand and liquid in the tank vapourizes as a result of weather changes (e.g. increase in atmospheric temperature)	ISO 28300 - 3.21
unstable detonation	detonation during the transition of a combustion process from a deflagration into a stable detonation. The transition occurs in a limited spatial zone where the velocity of the combustion wave is not constant and where the explosion pressure is significantly higher than in a stable detonation	ISO 16852 - 3.11
upper explosion limit (UEL)	the upper limit of the explosion range	EN 1127 - 3.9
valve lift	actual travel of the valve pallet away from the closed position, when a valve is relieving	-
valve pallet gasket	sealing element between valve pallet and valve seat	-
vent cap	end-of-line device for free out- and inbreathing of plant components. This device can be flame transmission proof	-
vent header	pipng system that collects and delivers the relief gases to the vent stack	ISO 23251 - 3.78
vent pipes	pipes connected to pipe away valves	EN 14015 - 3.1.45
venting system	system, which consists of pipeline and devices for free out- and inbreathing of parts of plants	-
venting system with flame arresting capability	free vents or pressure and/or vacuum valves combined with a flame arrester or with integrated flame arresting elements	DIN EN 14015 - 3.1.42



Appendix

Glossary

vessel	container or structural envelope in which materials are processed, treated or stored	ISO 23251 - 3.80
zone 0	place in which an explosive atmosphere consisting of a mixture with air of flammable substances in the form of gas, vapor or mist is present continuously or for long periods or frequently	EN 13237 - 3.119-1
zone 1	place in which an explosive atmosphere consisting of a mixture with air of flammable substances in the form of gas, vapor or mist is likely to occur in normal operation occasionally	EN 13237 - 3.119-2
zone 2	place in which an explosive atmosphere consisting of a mixture with air of flammable substances in the form of gas, vapor or mist is not likely to occur in normal operation but, if it does occur, will persist for a short period only	EN 13237 - 3.119-3
zones for gases/vapours	hazardous areas are classified into zones based upon the frequency of the occurrence and the duration of an explosive gas atmosphere, the definitions are only applicable to equipment group II	EN 13237 - 3.119

Materials, Terms and Conversion Tables

Pressure

1 bar	= 14.504 psi	1 lb/ft ²	= 47,88 N/m ²
	= 29.530 inch Hg		= 0,4788 mbar
	= 0.987 atm		= 4,882 mm WC
	= 401.46 inch W.C.		
1 mbar	= 0.0145 psi	1 inch W.C.	= 249,09 N/m ²
	= 0.0295 inch Hg		= 2,4909 mbar
	= 0.4015 inch W.C.		= 25,4 mm WC
	= 2.089 lb/ft ²	1 inch Hg	= 33,864 mbar
1 kPa	= 10 mbar	1 psi	= 68,94757 mbar
1 inch H ₂ O	= 2,49089 mbar	1 inch Hg	= 33,8639 mbar
1 Pa	= 1 N/m ²	1 psi	= 1 lb/in ²

Temperature

To convert °C in °F use	$T_F = 32 + 1,8 T_C$
	0°C = 32°F
	100°C = 212°F
To convert °F in °C use	$T_C = \frac{5}{9} (T_F - 32)$
	0°F = -17,8°C
	100°F = 37,8°C

Material

DIN Material Number	DIN-Material	ASTM-Material	
0.6020	GG 20	A 278-30	C.I.
0.7040	GGG 40	A 536-77	C.I.
1.0619	GS-C 25	A 216 Gr. WCB	C.S.
1.4301	X5 CrNi 18 10	A 240 Gr. 304	S.S.
1.4408	G-X6 CrNiMo 18 10	A 351 Gr. CF 8 M	S.S.
1.0425	P 265 GH	A 515 Gr. 60	C.S.
1.4541	X6 CrNiTi 18 10	A 240 Gr. 321	S.S.
1.4571	X10 CrNiMoTi 18 10	A 240 Gr. 316 Ti	S.S.
3.2581	AC 44200	A 413	Alu
Ta	Tantal	UNS R05200	
2.4610	NiMo 16 Cr 16 Ti	UNS N06455	C-4
2.4686	G-NiMo 17 Cr	UNS N30107	Casting
2.4602	NiCr 21 Mo 14 W	UNS N06022	C-22
2.4819	NiMo 16 Cr 15 W	UNS N10276	C-276

The applicable materials are specified in the quotation or the order acknowledgement:

In general the following means
 CS (Carbon steel) = 1.0619 or 1.0425
 SS (Stainless steel) = 1.4408 or 1.4571
 Hastelloy = 2.4686 or 2.4602

Important differences: US decimals in accordance to

SI-System

e.g. 1 m	= 100 cm	= 100,00 cm	(UK/US: 100.00 cm)
1 km	= 1.000 m	= 1.000,00 m	(UK/US: 1,000.00 m)

Sealings and Coatings

PTFE	= polytetrafluoroethylene
PVDF	= polyvinylidene fluoride
PFA	= perfluoralkoxy polymer
FPM 70	= fluoropolimer elastomer
WS 3822	= aramide and anorganic fibers as well as mineral reinforcement materials bonded with NBR rubber
ECTFE	= ethylene chlorotrifluoro etylene
FEP	= perfluoroethylene propylene

DN	10	15	20	25	32	40	50	65	80	100
Size	1/4	1/2	3/4	1	1 1/4	1 1/2	2	2 1/2	3	4

DN	125	150	200	250	300	350	400	450	500	600
Size	5	6	8	10	12	14	16	18	20	24

DN	700	800	900	1000	1200	1400	1600	1800	2000
Size	28	32	36	40	48	56	64	72	80

Length

1 cm	= 0.3937 inch	1 inch	= 25,4 mm
1 m	= 3.2808 ft	1 ft	= 12 inch = 0,3048 m
	= 1.0936 yards	1 yard	= 3 ft = 0,9144 m
1 km	= 0.621 miles	1 mile	= 1,609 km

Area

1cm ²	= 0.1550 sq inch	1 sq inch	= 6,4516 cm ²
1 m ²	= 10.7639 sq ft	1 sq ft	= 0,0929 m ²
	= 1.196 sq yards	1 sq yard	= 0,836 m ²
1km ²	= 100 hectares		
	= 0.3861 sq miles		
	= 247 acres		

Volume

1 cm ³	= 0.06102 cu inch	1 cu inch	= 16,3870 cm ³
1 liter	= 0.03531 cu ft	1 cu ft	= 28,317 liter
	= 0.21997 gal (UK)	1 gal (UK)	= 4,5461 liter
	= 0.26417 gal (US)	1 gal (US)	= 3,785 liter
1 m ³	= 35.315 cu ft	1 cu ft	= 0,028317 m ³
	= 6.290 petr. barrels	1 petr. barrel	= 0,15899 m ³

Mass

1 g	= 0.03527 oz	1 oz	= 28,35 g
1 kg	= 2.2046 lb	1 lb	= 16 oz
			= 0,4536 kg

Velocity and Volume Flow

1 m/s	= 196.85 ft/min	1 ft/min	= 0,508 cm/s
1 km/h	= 0.6214 mph	1 mph	= 1,60934 km/h
1 m ³ /h	= 4.403 gal/min (US)	1 gal/min (US)	= 0,227 m ³ /h
	= 3.666 gal/min (UK)	1 gal/min (UK)	= 0,273 m ³ /h
	= 0.5886 cu ft/min	1 cu ft/min	= 28,317 liter/min
1 kg/h	= 0.0367 lb/min	1 lb/min	= 27,216 kg/h
		1 cu ft/h	= 0,028317 m ³ /h

Torsion

1 Nm	= 0.738 lb ft	1 lb ft	= 1,36 Nm
------	---------------	---------	-----------

Density

1 kg/dm ³	= 62.43 lb/cu ft	1 lb/cu ft	= 0,016 kg/dm ³
----------------------	------------------	------------	----------------------------

Project Data Sheet

Quotation-No.

Project-No.

Valve / Flame Arrester Tag No.

Order-No.

Project Reference

Tank / Vessel No.

Storage Tank / Vessel

<input type="checkbox"/> aboveground	diameter	m/ft	design pressure	mbar/inch W.C.	
<input type="checkbox"/> underground	height	m/ft	design vacuum	mbar/inch W.C.	
<input type="checkbox"/> insulated	wall height	m/ft	pumping-in-rate	m ³ /h cu ft/min	
ins. thickness	mm / inch	blanketing level	m/ft	pumping-out-rate	m ³ /h cu ft/min
<input type="checkbox"/> inert gas	inert gas blanketing level		tank design standard		

Stored Product

Offgas/Vapour-Composition

Components Name	Formula	Vol.%	Flashpoint °C/°F	CAS	MESG mm/inch	Ex.- Group

Processing Plant

design temperature	°C/°F	design pressure	bar/psi		
operating temperature	°C/°F	operating pressure	bar/psi	back pressure	mbar/inch W.C.

Installation

<input type="checkbox"/> in-line	<input type="checkbox"/> horizontal	distance to source of ignition	m/ft
<input type="checkbox"/> end-of-line	<input type="checkbox"/> vertical		

Function

<input type="checkbox"/> pressure	<input type="checkbox"/> endurance burning proof	<input type="checkbox"/> temperature monitored on side
<input type="checkbox"/> vacuum	<input type="checkbox"/> short-time burning proof	<input type="checkbox"/> temperature monitored both side
<input type="checkbox"/> pressure/vacuum combined	<input type="checkbox"/> deflagration proof	<input type="checkbox"/> pressure monitored
	<input type="checkbox"/> detonation proof	<input type="checkbox"/> bidirectional flame arrester

Valve and Flame Arrester Data

size nominal DN	flow \dot{V}	m ³ /h cu ft/min	density	kg/m ³ lb/cu ft
pressure nominal PN	inlet flange	DN	PN	form
set pressure	mbar/inch W.C.	outlet flange	DN	PN form
set vacuum	mbar/inch W.C.	pressure drop Δp	mbar/inch W.C.	

Material

pressure carrying parts	internals	lining

Inspection/Documentation

material certificate	works certificate	performance certificate

Piping Flow Diagram (excerpt) / Additional Remarks / Miscellaneous → refer to separate sheet

Fill in and tick off, if applicable, delete unit, if not applicable

signed:

date:

approved:

released:



www.protego.com



PROTEGO

for safety and environment

PROTEGO® Deflagration Flame Arresters

end-of line
and Vent Caps

Volume 2



Volume 2



for safety and environment



Function and description

The different combustion processes and installation locations of flame arresters are discussed in „Technical Fundamentals“ (Vol. 1). In this volume we present the PROTEGO® product range for end-of-line deflagration flame arresters and vent caps. These devices protect against atmospheric deflagration, atmospheric deflagration and short time burning or atmospheric deflagration and endurance burning, which also includes short time burning. Vent caps without flame arrester elements complete our range of end-of-line devices.

PROTEGO® end-of-line deflagration flame arresters are “state-of-the-art” safety devices which are installed on storage tanks, vessels or in process plants. They provide safe protection against atmospheric deflagration, short time burning or endurance burning if potentially explosive vapours are discharged. They mitigate the impact of atmospheric deflagration and prevent flame transmission to protect equipment which is not designed to be explosion pressure proof.

The main component is the PROTEGO® flame arrester unit (1), which stops the propagation of flames. The PROTEGO® flame arrester unit consists of one or two FLAMEFILTER® discs which are secured in a FLAMEFILTER® cage (3). The gap size and number of FLAMEFILTER® discs depend on the relevant data of the process media (i.e. explosion group, pressure, temperature, composition of the fluid).

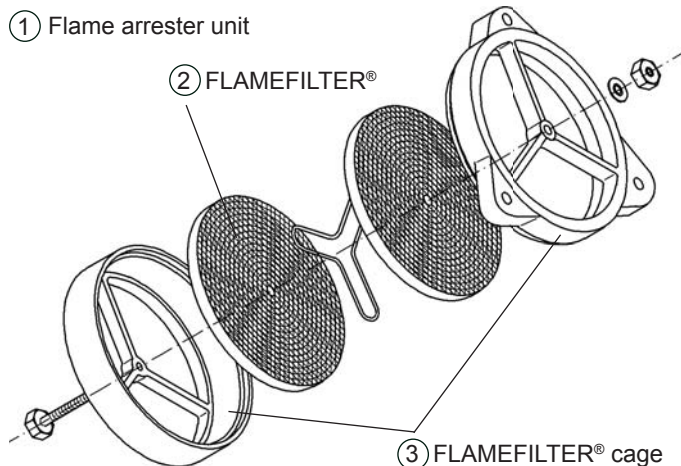

Deflagration and short time burning proof end-of-line flame arresters are equipped with a temperature sensor, which detects a stabilized flame on the flame arrester element. If a flame is detected, measures shall be taken to extinguish the flame and prevent endurance burning.

Should venting of an explosive mixture over a long period of time be unavoidable and no secondary measure is implemented to extinguish a flame, devices which provide endurance burning protection shall be installed. **Deflagration and endurance burning proof end-of-line flame arresters** from PROTEGO®, are equipped with a fusible link, which melts if a flame stabilizes on the flame arrester element and then allows the weather hood to move into the open position. This allows the flame to transfer most of its heat directly to the environment, preventing flashback through the FLAMEFILTER®.

Vent caps without flame arrester elements, protecting against environmental impact (harsh weather conditions, bird nests, etc.) complete our product range.

In close cooperation with scientific institutions, PROTEGO® has developed safety devices which can be applied to all explosion hazardous locations and provide protection against atmospheric deflagration, short time burning and endurance burning. Our devices are subjected to type examination and certificates according to ATEX and other international standards are issued (CE, Gost-R, GL, etc.).

A broad variety of types, designs, sizes and materials can be provided. Most importantly we have the capability to custom design and develop solutions in our test facility, which is the technologically most advanced in the world.

Special features and advantages

The following factors should be considered for selecting a device: **Deflagration protection, deflagration and short time burning protection** including temperature control or **deflagration and endurance burning protection**. **Vent caps** don't have a flame arrester element.

With regard to operating conditions **higher temperatures** have to be considered if standard values for atmospheric operation are exceeded.

For selecting an appropriate device, the **explosion group** according to the MESG value must be considered.

The correct **approval** has to be chosen or may be requested.

The plant specification needs to be considered to select the appropriate connection and **size**.

Depending on the application, it may be important to select a device with a **heating jacket** or heating coil, but please note that not all devices are available with this feature. Electrical trace heating may be an alternative.

We provide special designs for **critical media** and product properties (i.e. viscosity, density, crystallization and polymerization).

Preferred applications

PROTEGO® end-of-line deflagration flame arresters and vent caps are mainly installed on storage tanks and vessels of the chemical, petrochemical and pharmaceutical industry in order to protect them.

Installation and maintenance

The modular design of the end-of-line deflagration flame arresters assures the easiest possible maintenance. For onsite maintenance purposes, the device has to be installed in a location where it can be easily accessed. For larger sizes it may be necessary to provide lifting equipment. With trained personal maintenance is most efficient.

PROTEGO® end-of-line deflagration flame arresters are installed in explosion hazardous areas. It is important to select the correct device for the specific application. The manufacturer's statement of conformity confirms the tasks for which the deflagration flame arrester is suitable. The user documents proper use in accordance with the applicable safety regulations.

Selection

Based on main process data, the different types of devices can be selected from our product range:

- **Atmospheric deflagration proof, short time burning proof, endurance burning proof or vent caps**
- **Explosion group** of the processed mixture
- Standard or special operating conditions with **higher temperatures**

After that the following criteria have to be verified or selected:

- **Size** and type of connection
- **Approvals** according to ATEX, etc.
- **Heating jacket** or heating coil

After this pre-selection other details, such as material, coating etc. can be selected or defined in the data sheet.

Should it not be possible to determine a device fitting your requirements, please do not hesitate to contact us: in many cases we can provide special designs or approvals.

Sizing

The size of the device is selected or double checked with our volume flow / pressure drop diagrams. Should clogging of the flame arrester element be likely a safety factor should be considered for sizing.

Given: Flow rate \dot{V} m³/h or CFH
max. all. pressure drop □ p in mbar or inch W.C.

Desired: Size of the device DN

Procedure: Intersection point of straight line through the flow rate and maximum allowable pressure drop is above or on the size curve

Given: Flow rate \dot{V} m³/h or CFH
size of nozzle connection DN

Desired: Pressure drop (flow resistance) □ p in mbar or inch W.C.

Procedure: Intersection point of the straight line through the flow rate and size curve, horizontal straight line provides the pressure drop

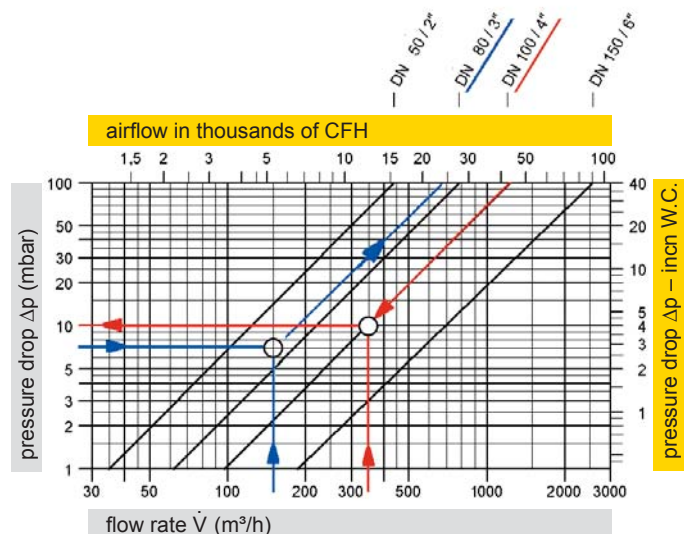









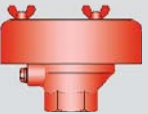
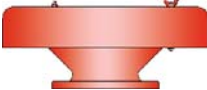

Guidance for calculating the volume flow or influence of density is covered in the "Technical Fundamentals" (see Vol. 1).



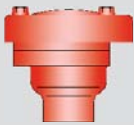













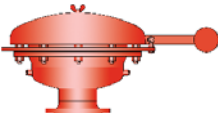

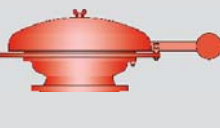
The device can be specified or ordered if all above steps are completed.

For special applications, please complete the process data sheet from Volume 1 to provide the necessary information for a quotation.

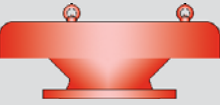

PROTEGO® Deflagration Flame Arresters, end-of-line, and Vent Caps

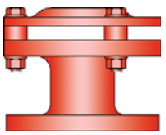
	Type	Size DN	Explosion group		Approvals			X = Special design for higher temperatures	X = Heating jacket / heating coil	Page
			ATEX	NEC						
Deflagration flame arrester, end-of-line										
	BE/AD	15 - 50 ½" - 2"	IIB3, IIC	C B	ATEX					64 - 66
	LH/AD	50 - 800 2" - 32"	IIB3, IIC	C B	ATEX		X			68 - 70
Deflagration flame arrester, short time burning proof, end-of-line										
	LH/AD-T	50 - 800 2" - 32"	IIB3, IIC	C B	ATEX		X			72 - 74
Deflagration flame arrester, endurance burning proof, end-of-line										
	EB	25 - 800 1" - 32"	IIA, IIB	D B	ATEX					76 - 79
	EB-DN/DN2	20 - 700 ¾" - 28"	IIA, IIB	D B	ATEX		X	X		76 - 79
	EB-Z	15 - 32 ½" - 1¼"	IIA	D	ATEX				NEW 	
	BE/HK	20 - 80 ¾" - 3" 20 - 32 ¾" - 1¼"	IIA, IIB3	D C	ATEX			X		
	BE/HK-E	20 - 80 ¾" - 3"	IIB1	–	ATEX			X		80 - 81
	BE/HK-E	80 3"	IIB3	C	ATEX IMO			X		

	Type	Size DN	Explosion group		Approvals			X = Special design for higher temperatures	X = Heating jacket / heating coil	Page
			ATEX	NEC						
Deflagration flame arrester, endurance burning proof, end-of-line (Continuation)										
	BE/HR	80 - 100 3" - 4"	IIA, IIB3	D C	ATEX			X	 	
	BE/HR-E	80 - 100 3" - 4"	IIB1	-	ATEX			X	82 - 83	
	BE/HR-E	80 - 100 3" - 4"	IIB3, IIB	C B	ATEX IMO			X	 	
	BE/HR 400	150 - 200 6" - 8"	IIA	D	ATEX			X	 	
	LH/EB	150 - 400 6" - 16"	IIA1 (I)	-	ATEX				 	
Vent caps, end-of-line, without flame arrester unit										
	EH/0	20 - 80 ¾" - 3"							 	
	EH/OS	100 - 600 4" - 24"							 	
	E/KS	50 - 200 2" - 8"							 	

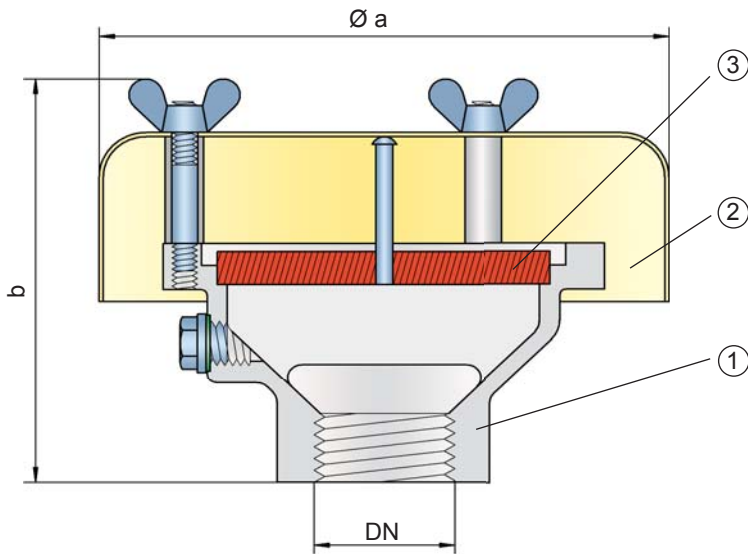
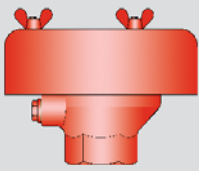

Function and Description

The PROTEGO® BE/AD end-of-line deflagration flame arrester provides protection against atmospheric deflagrations. The device is typically installed on vent lines of small vessels and plant equipment which is not pressurized. For safe application it is important that an endurance burning situation can be excluded, so typically it is installed on vents lines which discharge vapour for a short time period only. The device prevents flame transmission from atmospheric deflagration into the vessel or plant.

The PROTEGO® BE/AD consists of a housing (1), a weather hood (2) and the PROTEGO® flame arrester unit (3). The device is equipped with a metal weather hood. The FLAMEFILTER® gap size will depend on the devices intended use. Detailing the operating conditions such as the temperature, pressure, explosion group and the composition of the fluid, enables PROTEGO® to select the best end-of-line deflagration flame arrester for your application. The PROTEGO® BE/AD series end-of-line deflagration flame arrester is available for substances from explosion groups IIA to IIC (NEC groups D to B).

The standard design can be used with operating temperature of up to +60°C / 140°F.

Type-approved in accordance with the current ATEX Directive and EN ISO 16852 as well as other international standards.

Special Features and Advantages

- Weather hood provides protection against environmental impact (harsh weather conditions, bird nests, etc.)
- easy maintenance
- quick removal of FLAMEFILTER®
- available with threaded connection
- provides protection against atmospheric deflagration
- low operating and lifecycle cost
- cost effective device
- cost effective spare parts

Design Type and Specification

Deflagration flame arrester, end-of-line, basic design **BE/AD**

Special designs available on request

Table 1: Dimensions

Dimensions in mm / inches

To select the nominal size (DN), please use the flow capacity charts on the following pages

DN	15 / G ½"	20 / G ¾"	25 / G 1"	32 / G 1¼"	40 / G 1½"	50 / G 2"
a	116 / 4.57	116 / 4.57	116 / 4.57	116 / 4.57	200 / 7.87	200 / 7.87
b	80 / 3.15	80 / 3.15	85 / 3.35	85 / 3.35	150 / 5.91	150 / 5.91

Table 2: Selection of explosion group

MESG	Expl. Gr. (IEC/CEN)	Gas Group (NEC)	
≥ 0,65 mm	IIB3	C	Special approvals upon request
< 0,5 mm	IIC	B	

Table 3: Specification of max. operating temperature

≤ 60°C / 140°F	Tmaximum allowable operating temperature in °C	
-	Designation	higher operating temperatures upon request

Table 4: Material selection

Design	A	B	C	
Housing	Steel	Stainless Steel	Hastelloy	Special materials upon request
Weather hood	Stainless Steel	Stainless Steel	Stainless Steel	
FLAMEFILTER®	Stainless Steel	Stainless Steel	Hastelloy	

Table 5: Type of connection

Pipe thread DIN ISO 228-1	DIN	other types of thread upon request
---------------------------	-----	------------------------------------



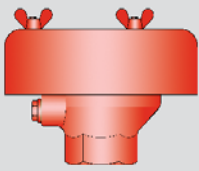

Deflagration Flame Arrester, End-of-Line

Flow Capacity Charts

PROTEGO® BE/AD

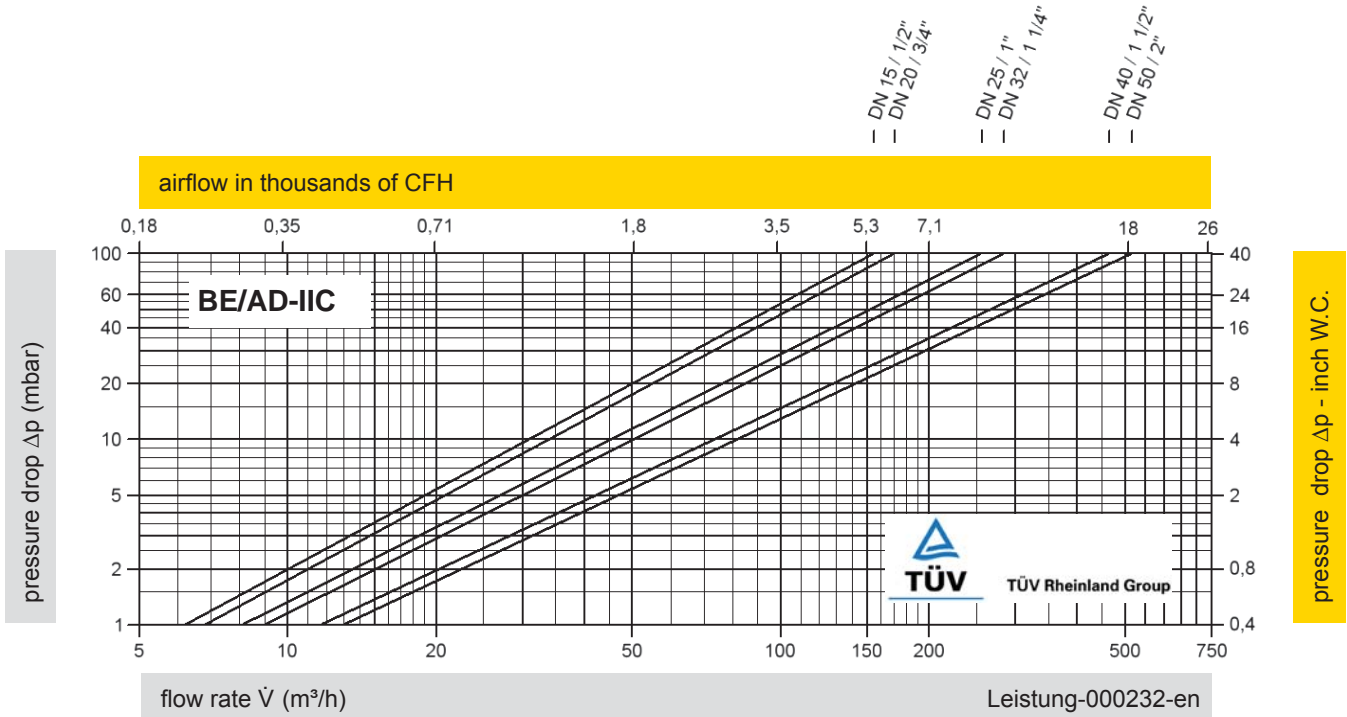
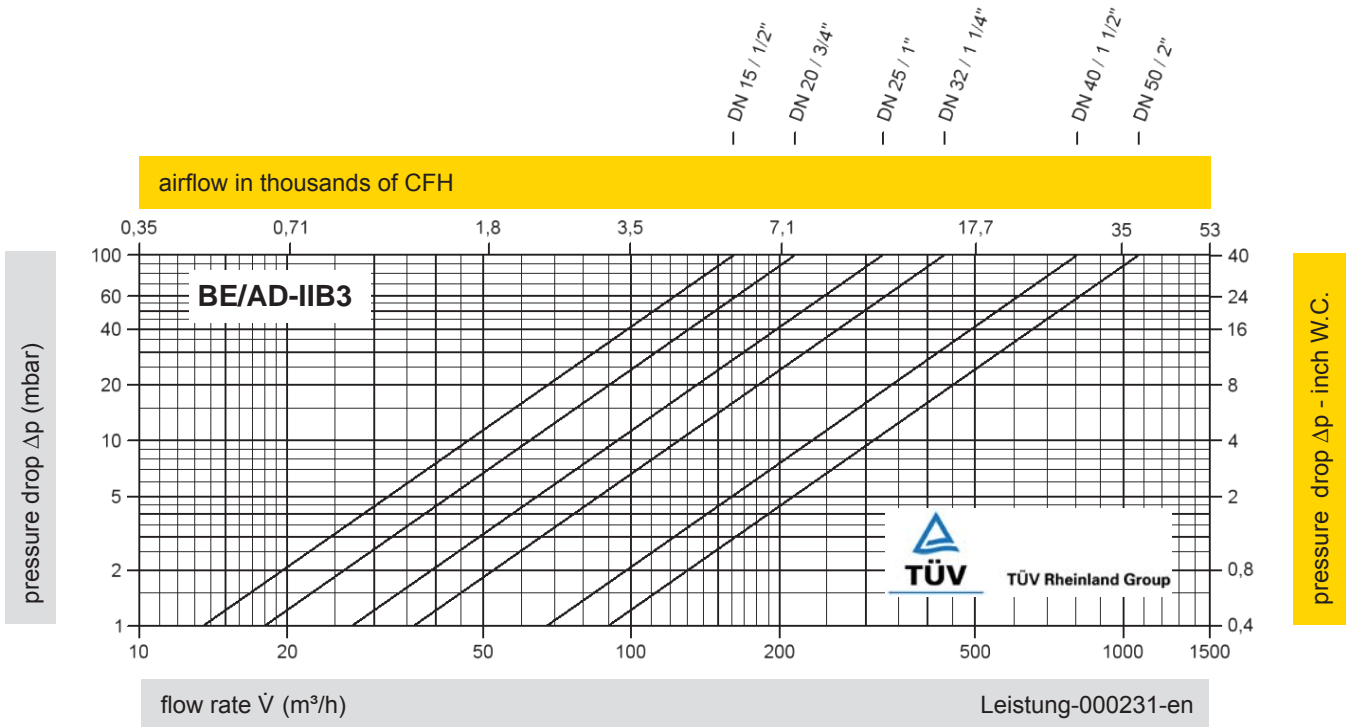

The flow capacity charts have been determined with a calibrated and TÜV certified flow capacity test rig. Volume flow \dot{V} in (m³/h) and CFH refer to the standard reference conditions of air ISO 6358 (20°C, 1bar). Conversion to other densities and temperatures refer to Vol. 1: "Technical Fundamentals".

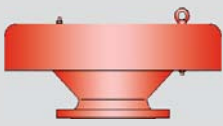

PROTEGO® LH/AD

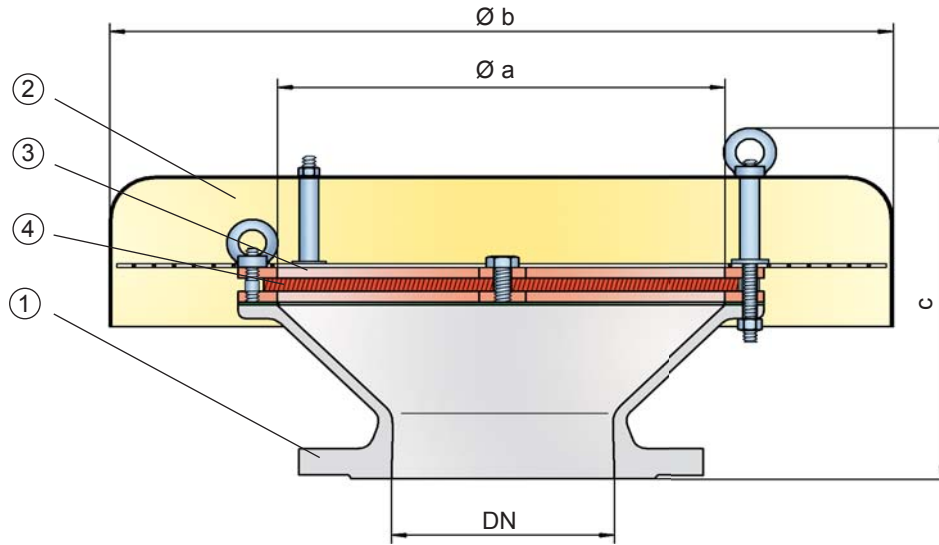

Function and Description

The PROTEGO® LH/AD end-of-line deflagration flame arrester provides protection against flame transmission through atmospheric deflagration. The device is typically installed on vent lines of vessels and process engineering apparatus which are not pressurized. For safe application it is important that an endurance burning situation can be excluded, so typically it is installed on vent lines which discharge vapour for a short time period only. The device prevents flame transmission from atmospheric deflagration into the vessel or plant.

The PROTEGO® LH/AD consists of a housing (1), a weather hood (2) and the PROTEGO® flame arrester unit (3). The device is equipped with a metal weather hood. A protection screen is installed between the weather hood and the housing to keep animals out. The FLAMEFILTER® (4) gap size will depend on the devices intended use. Detailing the operating conditions such as the temperature, explosion group and the composition of the fluid, enables PROTEGO® to select the best end-of-line deflagration flame arrester for your application.

The PROTEGO® LH/AD series end-of-line deflagration flame arrester is available for substances from explosion groups IIA to IIC (NEC groups D to B). Special certifications for carbon disulfide are available.

The standard design can be used with operating temperature of up to +60°C / 140°F. Devices with special approval can be obtained for higher temperatures upon request.

Type-approved in accordance with the current ATEX Directive and EN ISO 16852 as well as other international standards.

Special Features and Advantages

- weather hood provides protection against environmental impact (harsh weather conditions, bird nests, etc.)
- available in sizes DN 50 (2") – up to DN 800 (32")
- easy maintenance
- available for elevated operating temperatures
- protection against atmospheric deflagration
- low operating and lifecycle cost
- cost effective device
- cost effective spare parts

Design Type and Specification

End-of-line deflagration flame arrester, basic design

LH/AD

End-of-line deflagration flame arrester for carbon disulfide

LH/AD-CS2

NEW

Special designs available on request

Table 1: Dimensions

Dimensions in mm / inches

To select the nominal size (DN), please use the flow capacity charts on the following pages

DN	a	b	IIB3	IIC
			c*	c*
50 / 2"	100 / 3.94	200 / 7.87	170 / 6.69	185 / 7.28
80 / 3"	150 / 5.91	240 / 9.45	180 / 7.09	195 / 7.68
100 / 4"	200 / 7.87	295 / 11.61	220 / 8.66	235 / 9.25
125 / 5"	250 / 9.84	350 / 13.78	240 / 9.45	-
150 / 6"	300 / 11.81	550 / 21.65	260 / 10.24	270 / 10.63
200 / 8"	300 / 11.81	550 / 21.65	260 / 10.24	270 / 10.63
250 / 10"	400 / 15.75	600 / 23.62	355 / 13.98	365 / 14.37
300 / 12"	400 / 15.75	600 / 23.62	340 / 13.39	350 / 13.78
350 / 14"	600 / 23.62	800 / 31.50	390 / 15.35	400 / 15.75
400 / 16"	600 / 23.62	800 / 31.50	380 / 14.96	390 / 15.35
500 / 20"	700 / 27.56	1000 / 39.37	400 / 15.75	410 / 16.14
600 / 24"	800 / 31.50	1200 / 47.24	475 / 18.70	485 / 19.09
700 / 28"	1000 / 39.37	1400 / 55.12	505 / 19.88	515 / 20.28
800 / 32"	1200 / 47.24	1600 / 62.99	550 / 21.65	560 / 22.05

* c are reference values. Exact measures depend on the flange connection.

Table 2: Selection of explosion group

MESG	Expl. Gr. (IEC/CEN)	Gas Group (NEC)	
≥ 0,65 mm	IIB3	C	Special approvals upon request
< 0,5 mm	IIC	B	

Table 3: Specification of max. operating temperature

≤ 60°C / 140°F	Tmaximum allowable operating temperature in °C	
-	Designation	higher operating temperatures upon request

Table 4: Material selection for housing

Design	A	B	
Housing	Steel	Stainless Steel	Special materials upon request
Weather hood	Stainless Steel	Stainless Steel	
Protection screen	Stainless Steel	Stainless Steel	
Flame arrester unit	A, B	B	

Table 5: Material combinations of flame arrester unit

Design	A	B	
FLAMEFILTER® cage	Steel	Stainless Steel	Special materials upon request
FLAMEFILTER®	Stainless Steel	Stainless Steel	

Table 6: Flange connection type

EN 1092-1; Form B1	other types upon request
ASME B16.5; 150 lbs RFSF	



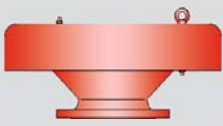

Deflagration Flame Arrester, End-of-Line

Flow Capacity Charts

PROTEGO® LH/AD

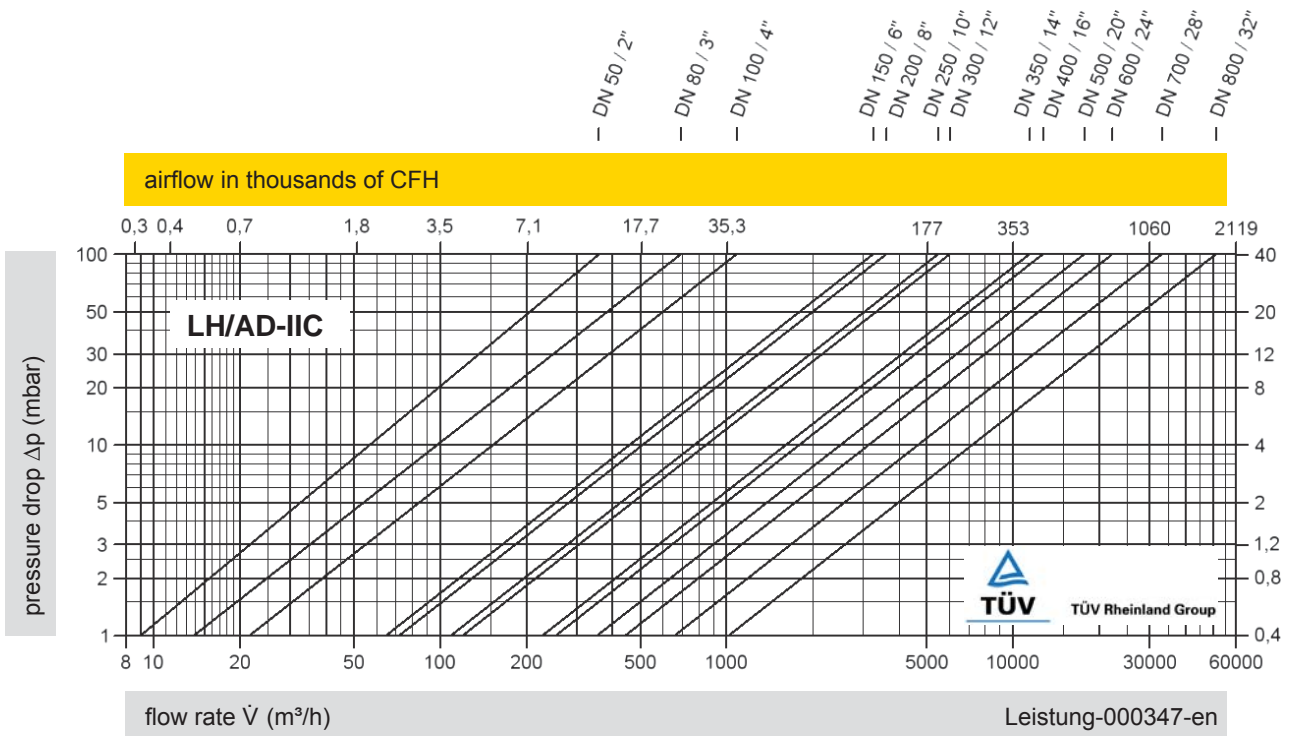
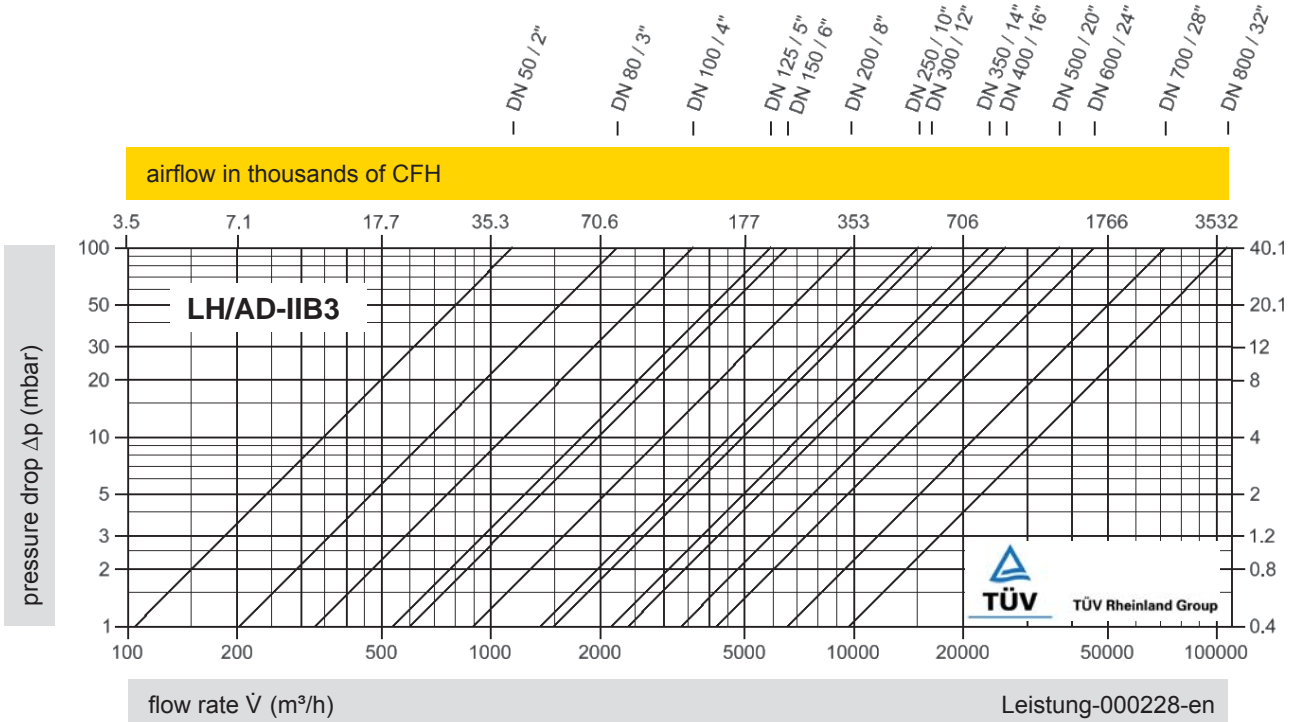

The flow capacity charts have been determined with a calibrated and TÜV certified flow capacity test rig. Volume flow \dot{V} in (m³/h) and CFH refer to the standard reference conditions of air ISO 6358 (20°C, 1bar). Conversion to other densities and temperatures refer to Vol. 1: "Technical Fundamentals".

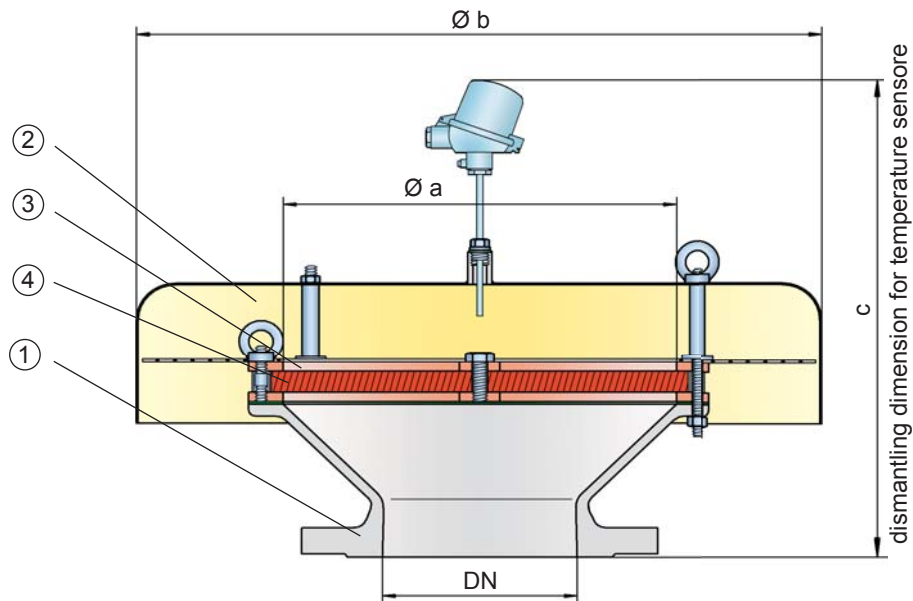
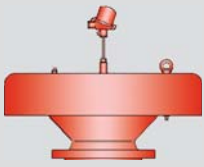

Function and Description

The PROTEGO® LH/AD-T end-of-line deflagration flame arrester provides protection against flame transmission through atmospheric deflagration and short time burning on the flame arrester element. The device is typically installed on vent lines of vessels and process engineering apparatus which are not pressurized. The device is equipped with a temperature sensor which immediately detects a flame on the FLAMEFILTER® surface. After the flame is detected, a secondary measure, such as inerting or closing of a shut-off valve to block the vapour flow to the device, should activate within 60 seconds and extinguish the flame, so that the plant can operate safely. The device prevents flame transmission from short time burning and atmospheric deflagration into the vessel or plant.

The PROTEGO® LH/AD-T consists of a housing (1), a weather hood (2) and the PROTEGO® flame arrester unit (3). The device is equipped with a metal weather hood. The FLAMEFILTER® (4) gap size depends on the devices intended use. Detailing the operating conditions such as the temperature, explosion group and the composition of the fluid, enables PROTEGO® to select the best end-of-line deflagration flame arrester for your application. The PROTEGO® LH/AD series end-of-line deflagration flame arrester is available for substances from explosion groups IIA to IIC (NEC groups D to B).

The standard design can be used with operating temperature of up to +60°C / 140°F. Devices with special approval can be obtained for higher temperatures upon request.

Type-approved in accordance with the current ATEX Directive and EN ISO 16852 as well as other international standards.

Special Features and Advantages

- weather hood provides protection against environmental impact (harsh weather conditions, bird nests, etc.)
- available in sizes DN 50 (2") – up to DN 800 (32")
- easy maintenance
- available for elevated operating temperatures
- protection against short time burning and atmospheric deflagration
- low operating and lifecycle cost
- cost effective device
- cost effective spare parts

Design Type and Specification

End-of-line deflagration flame arrester, basic design **LH/AD-T**

Special designs available on request

Table 1: Dimensions

Dimensions in mm / inches

To select the nominal size (DN), please use the flow capacity charts on the following pages

DN	a	b	IIB3	IIC
			c*	c*
50 / 2"	100 / 3.94	240 / 9.45	530 / 20.87	550 / 21.65
80 / 3"	150 / 5.91	295 / 11.61	560 / 22.05	580 / 22.83
100 / 4"	200 / 7.87	350 / 13.78	585 / 23.03	605 / 23.82
150 / 6"	300 / 11.81	600 / 23.62	630 / 24.80	655 / 25.79
200 / 8"	300 / 11.81	600 / 23.62	630 / 24.80	655 / 25.79
250 / 10"	400 / 15.75	800 / 31.50	750 / 29.53	770 / 30.31
300 / 12"	400 / 15.75	800 / 31.50	740 / 29.13	760 / 29.92
350 / 14"	600 / 23.62	1000 / 39.37	800 / 31.50	820 / 32.28
400 / 16"	600 / 23.62	1000 / 39.37	790 / 31.10	815 / 32.09
500 / 20"	700 / 27.56	1200 / 47.24	810 / 31.89	835 / 32.87
600 / 24"	800 / 31.50	1200 / 47.24	935 / 36.81	960 / 37.80
700 / 28"	1000 / 39.37	1500 / 59.06	975 / 38.39	995 / 39.17
800 / 32"	1200 / 47.24	1700 / 66.93	1015 / 39.96	1035 / 40.75

* c are reference values. Exact measures depend on the flange connection.

Table 2: Selection of explosion group

MESG	Expl. Gr. (IEC/CEN)	Gas Group (NEC)	Special approvals upon request
≥ 0,65 mm	IIB3	C	
< 0,5 mm	IIC	B	

Table 3: Specification of max. operating temperature

≤ 60°C / 140°F	Tmaximum allowable operating temperature in °C	higher operating temperatures upon request
-	Designation	

Table 4: Material selection for housing

Design	A	B	Special materials upon request
Housing	Steel	Stainless Steel	
Weather hood	Stainless Steel	Stainless Steel	
Protection screen	Stainless Steel	Stainless Steel	
Flame arrester unit	A, B	B	

Table 5: Material combinations of flame arrester unit

Design	A	B	Special materials upon request
FLAMEFILTER® cage	Steel	Stainless Steel	
FLAMEFILTER®	Stainless Steel	Stainless Steel	

Table 6: Flange connection type

EN 1092-1; Form B1	other types upon request
ASME B16.5; 150 lbs RFSF	



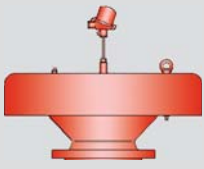

Deflagration Flame Arrester, short time burning-proof, End-of-Line Flow Capacity Charts

PROTEGO® LH/AD-T

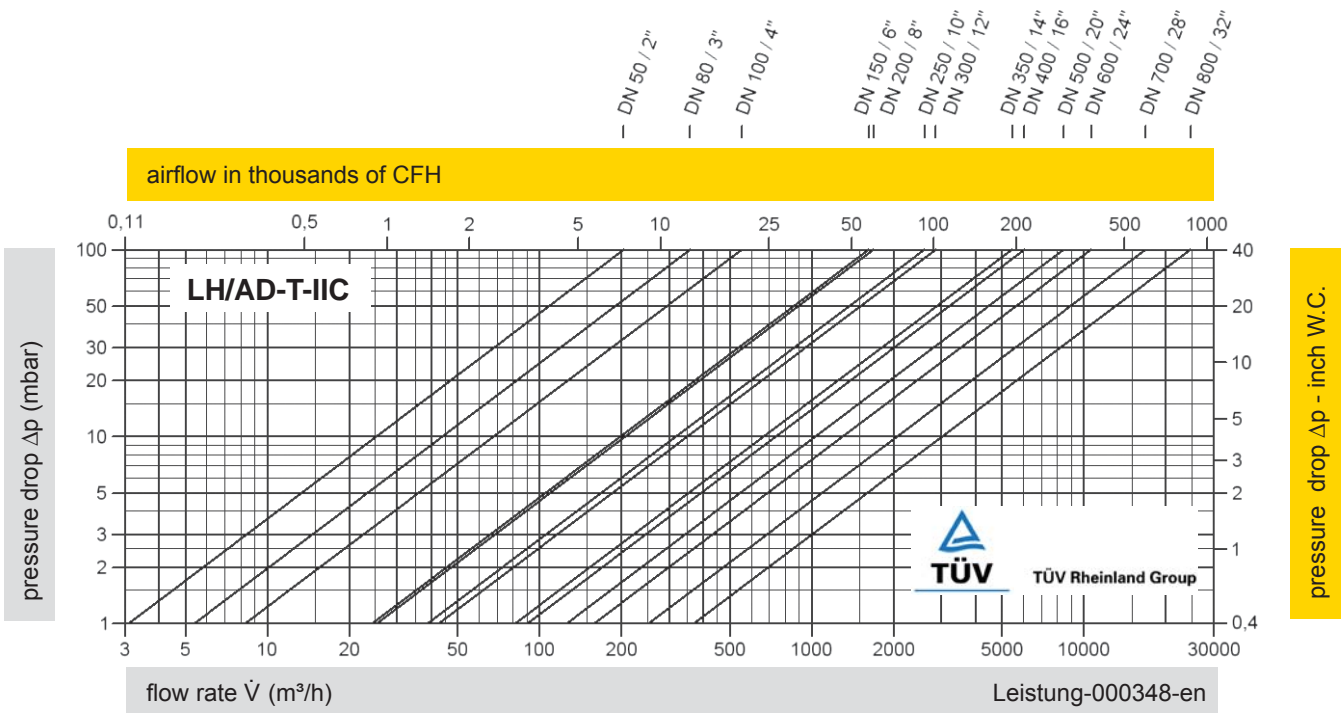
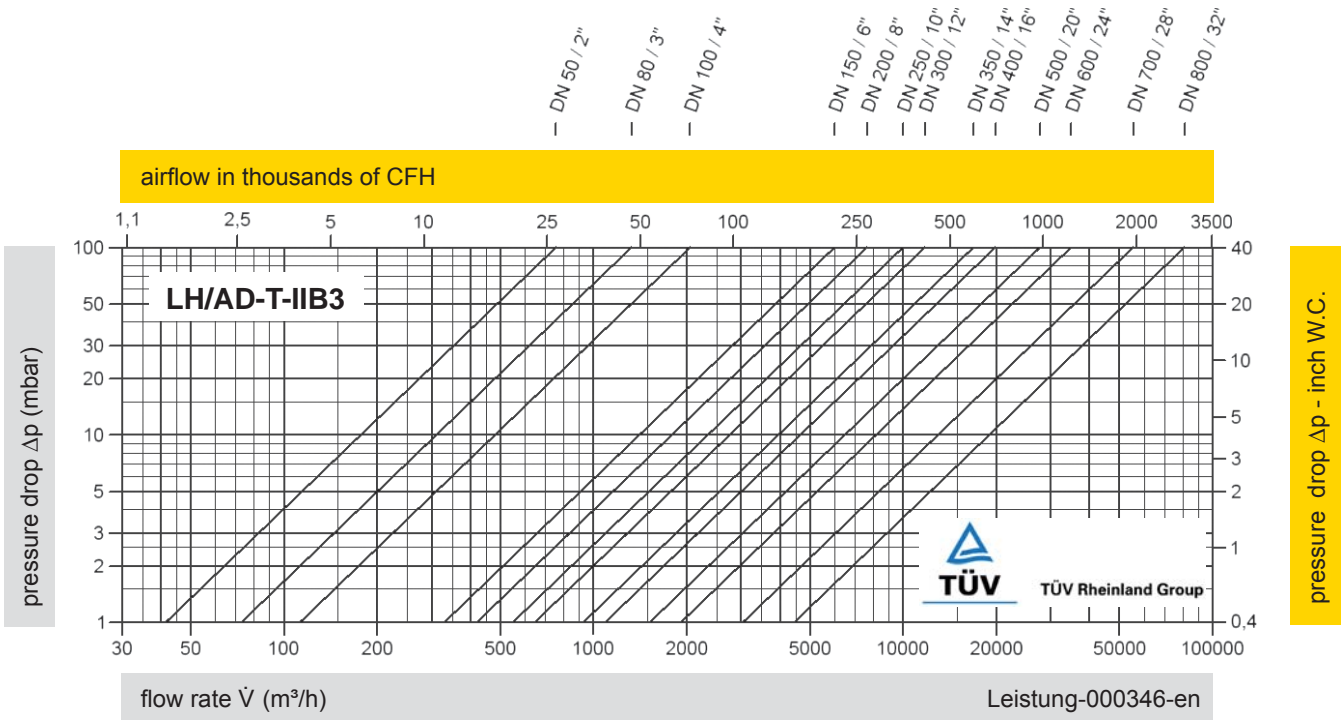

The flow capacity charts have been determined with a calibrated and TÜV certified flow capacity test rig. Volume flow \dot{V} in (m³/h) and CFH refer to the standard reference conditions of air ISO 6358 (20°C, 1bar). Conversion to other densities and temperatures refer to Vol. 1: "Technical Fundamentals".



PROTEGO® EB-IIA and IIB

DN 25 - 150 / 1" - 6"

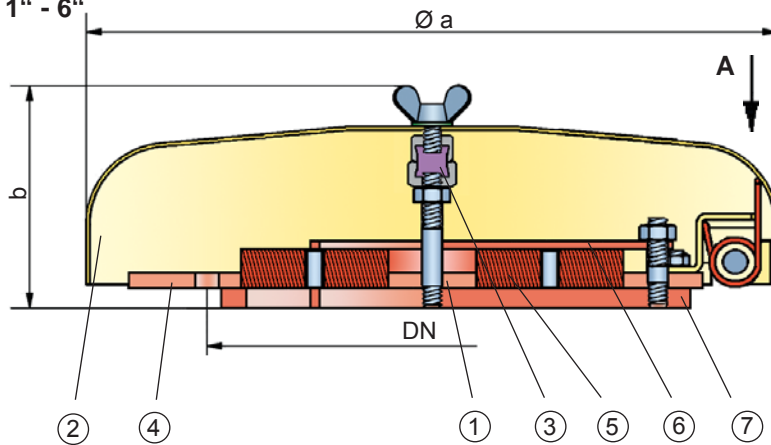

View A

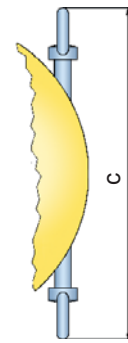

DN 200 - 800 / 8" - 32"

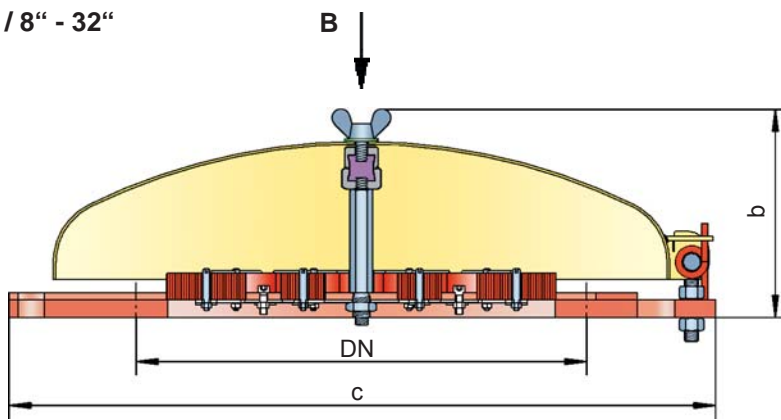

View B

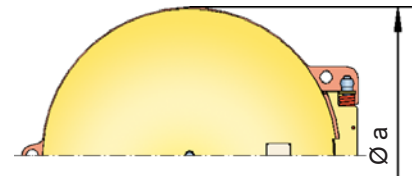

DN 25 - 150 / 1" - 6"

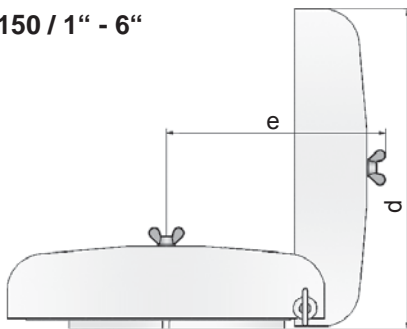

DN 200 - 800 / 8" - 32"

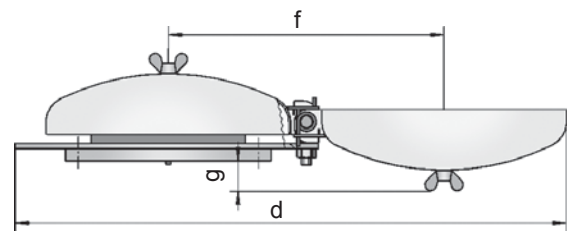

EB with cone (example)

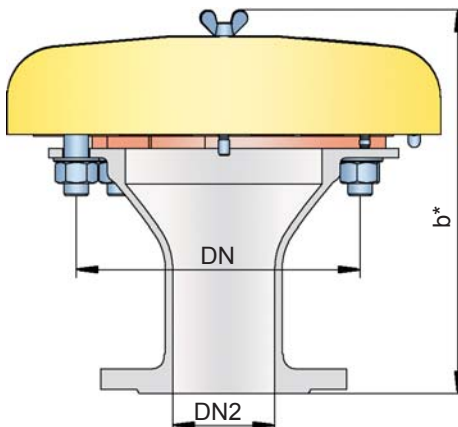

EB with nozzle (example)

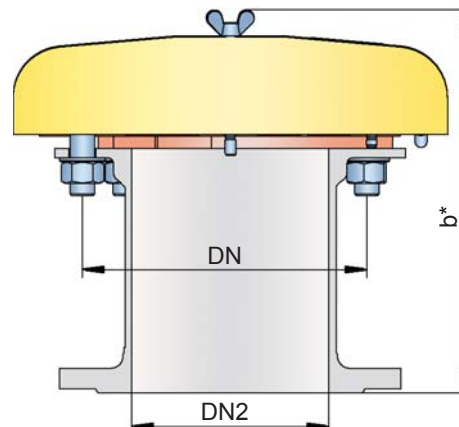



PROTEGO® EB
(Flyer pdf)



Demonstration of endurance burning
Video

Function and Description

The PROTEGO® EB end-of-line deflagration flame arrester has been successfully used to protect vessels and plants which are not pressurized. The device provides protection against atmospheric deflagration and stabilized flames which can burn for very long time on the flame arrester element surface, so called endurance burning. Main application area is on suction and vent lines, with the goal to prevent flame transmission caused by endurance burning or atmospheric deflagration from propagating into the vessel or plant.

The PROTEGO® EB-IIA consists of the PROTEGO® flame arrester unit (1) and the metal weather hood (2). During normal operation the metal weather hood is in a closed position. If a stabilized flame burns on the flame arrester element surface, the fusible link (3), located in a center position, will melt and let the spring loaded weather hood move into the open position. The PROTEGO® flame arrester unit consists of one or more FLAMEFILTER® (5), which are installed in a FLAMEFILTER® cage (4), a intersecting ribs (6) and a spider ring (7). The FLAMEFILTER® gap size, the height and the quantity depend on the devices intended use.

The PROTEGO® EB series end-of-line deflagration flame arrester is available for substances from explosion group IIA and IIB (NEC group D and B).

The standard design can be used with operating temperature of up to +60°C / 140°F. Devices with special approval can be obtained for higher temperatures upon request.

Type-approved in accordance with the current ATEX Directive and EN ISO 16852 as well as other international standards.

Special Features and Advantages

- weather hood protects against environmental impact (i.e. weather, bird nests, etc.)
- weather hood will open and signal the impact of a flame
- protection against atmospheric deflagration and endurance burning of pure hydrocarbons
- fusible link is resistant against chemicals
- modular design allows replacement of single FLAMEFILTER®
- easy maintenance without disassembling of the FLAMEFILTER®
- modular design results in low spare part costs

Design Types and Specifications

End-of-line deflagration flame arrester, basic design	EB
End-of-line deflagration flame arrester, with cone	EB - DN/DN2
End-of-line deflagration flame arrester, with cone and heating jacket	EB - H - DN/DN2
Special designs available on request	

Table 1: Dimensions DN 25 - 150 / 1" - 6"
EB-IIA and EB-IIB

Dimensions in mm / inches

To select the nominal size (DN), please use the flow capacity chart on the following page

DN	25 / 1"	32 / 1¼"	40 / 1½"	50 / 2"	65 / 2½"	80 / 3"	100 / 4"	125 / 5"	150 / 6"
a	218 / 8.58	218 / 8.58	218 / 8.58	218 / 8.58	218 / 8.58	353 / 13.90	353 / 13.90	353 / 13.90	353 / 13.90
b	113 / 4.45	113 / 4.45	113 / 4.45	113 / 4.45	113 / 4.45	113 / 4.45	113 / 4.45	113 / 4.45	113 / 4.45
c	232 / 9.13	232 / 9.13	232 / 9.13	232 / 9.13	232 / 9.13	306 / 12.05	306 / 12.05	306 / 12.05	306 / 12.05
d	222 / 8.74	222 / 8.74	222 / 8.74	222 / 8.74	222 / 8.74	355 / 13.98	355 / 13.98	355 / 13.98	355 / 13.98
e	217 / 8.54	217 / 8.54	217 / 8.54	217 / 8.54	217 / 8.54	322 / 12.68	322 / 12.68	322 / 12.68	322 / 12.68

EB-IIA und IIB with cone/nozzle**

DN				50 / 2"		80 / 3"	100 / 4"		150 / 6"
DN2				≤ 50 / 2"		≤ 80 / 3"	≤ 100 / 4"		≤ 150 / 6"
b*				238 / 9.37		263 / 10.35	383 / 15.08		313 / 12.32

Dimensions DN 200 - 800 / 8" - 32"

EB-IIA

DN	200 / 8"	300 / 12"	400 / 16"	500 / 20"	600 / 24"	800 / 32"
a	405 / 15.94	555 / 21.85	705 / 27.75	855 / 33.66	1005 / 39.57	1210 / 47.64
b	177 / 6.97	206 / 8.11	235 / 9.25	265 / 10.43	294 / 11.57	330 / 12.99
c	496 / 19.53	650 / 25.59	802 / 31.57	987 / 38.86	1137 / 44.76	1336 / 52.60
d	900 / 35.43	1200 / 47.24	1500 / 59.06	1820 / 71.65	2120 / 83.46	2525 / 99.41
f	450 / 17.72	600 / 23.62	750 / 29.53	920 / 36.22	1070 / 42.13	1270 / 50.00
g	51 / 2.01	80 / 3.15	109 / 4.29	138 / 5.43	167 / 6.57	204 / 8.03

** combinations (DN/DN2) please use the table on the following page

EB-IIA with cone/nozzle**

DN	200 / 8"	300 / 12"	400 / 16"	500 / 20"	600 / 24"	800 / 32"
DN2	≤ 200 / 8"	≤ 300 / 12"	≤ 400 / 16"	≤ 500 / 20"	≤ 600 / 24"	≤ 800 / 32"
b*	401 / 15.94	456 / 17.95	535 / 21.06	614 / 24.17	693 / 27.28	830 / 32.68



for safety and environment



Deflagration Flame Arrester, endurance burning proof, End-of-Line

PROTEGO® EB-IIA and IIB

Table 2: Combination (DN/DN2) for EB with cone

Remarks: Flow capacity charts for EB-DN/DN2-IIA/IIB with cone upon request

DN	50/2"	80/3"	100/4"	150/6"	200/8"	300/12"	400/16"	500/20"	600/24"	800/32"
DN2										
20/¾"	IIA/IIB	IIA/IIB	IIA/IIB	IIA/IIB						
25/1"	IIA/IIB	IIA/IIB	IIA/IIB	IIA/IIB						
32/1¼"	IIA/IIB	IIA/IIB	IIA/IIB	IIA/IIB						
40/1½"	IIA/IIB	IIA/IIB	IIA/IIB	IIA/IIB						
50/2"	IIA/IIB	IIA/IIB	IIA/IIB	IIA/IIB	IIA					
65/2½"		IIA/IIB	IIA/IIB	IIA/IIB						
80/3"		IIA/ IIB	IIA/ IIB	IIA/ IIB	IIA	IIA				
100/4"			IIA/ IIB	IIA/ IIB	IIA	IIA				
125/5"				IIA/ IIB	IIA					
150/6"				IIA/ IIB	IIA	IIA	IIA			
200/8"					IIA	IIA	IIA	IIA	IIA	
250/10"						IIA	IIA	IIA		
300/12"							IIA	IIA	IIA	
350/14"								IIA	IIA	
400/16"								IIA	IIA	IIA
450/18"								IIA	IIA	IIA
500/20"									IIA	IIA
600/24"										IIA
700/28"										IIA

Table 3: Selection of explosion group

MESG	Expl. Gr. (IEC/CEN)	Gas Group (NEC)	
> 0,90 mm	IIA	D	Special approvals upon request
≥ 0,50 mm	IIB	B	

Table 4: Specification of max. operating temperature

≤ 60°C / 140°F	Tmaximum allowable operating temperature in °C	higher operating temperatures upon request
-	Designation	

Table 5: Material selection for housing

Design	A	B	
flange ring	Steel	Stainless Steel	Special materials upon request
Weather hood	Steel	Stainless Steel	
cone/nozzle	Steel	Stainless Steel	
Flame arrester unit	A, B, C	B, C	

Table 6: Material combinations of flame arrester unit

Design	A	B	C	
FLAMEFILTER® cage	Steel	Stainless Steel	Stainless Steel/Hastelloy	Special materials upon request
FLAMEFILTER®	Stainless Steel	Stainless Steel	Hastelloy	
Spider ring/safety bar	Stainless Steel	Stainless Steel	Stainless Steel/Hastelloy	

Table 7: Flange connection type

EN 1092-1 (without cone); EN 1092-1; Form B1 (with cone/nozzle)	other types upon request
ASME B16.5 (without cone); ASME B16.5; 150 lbs RFSF (with cone/nozzle)	

PROTEGO® EB-IIA and IIB
without cone

* use with nozzle (DN=DN2)

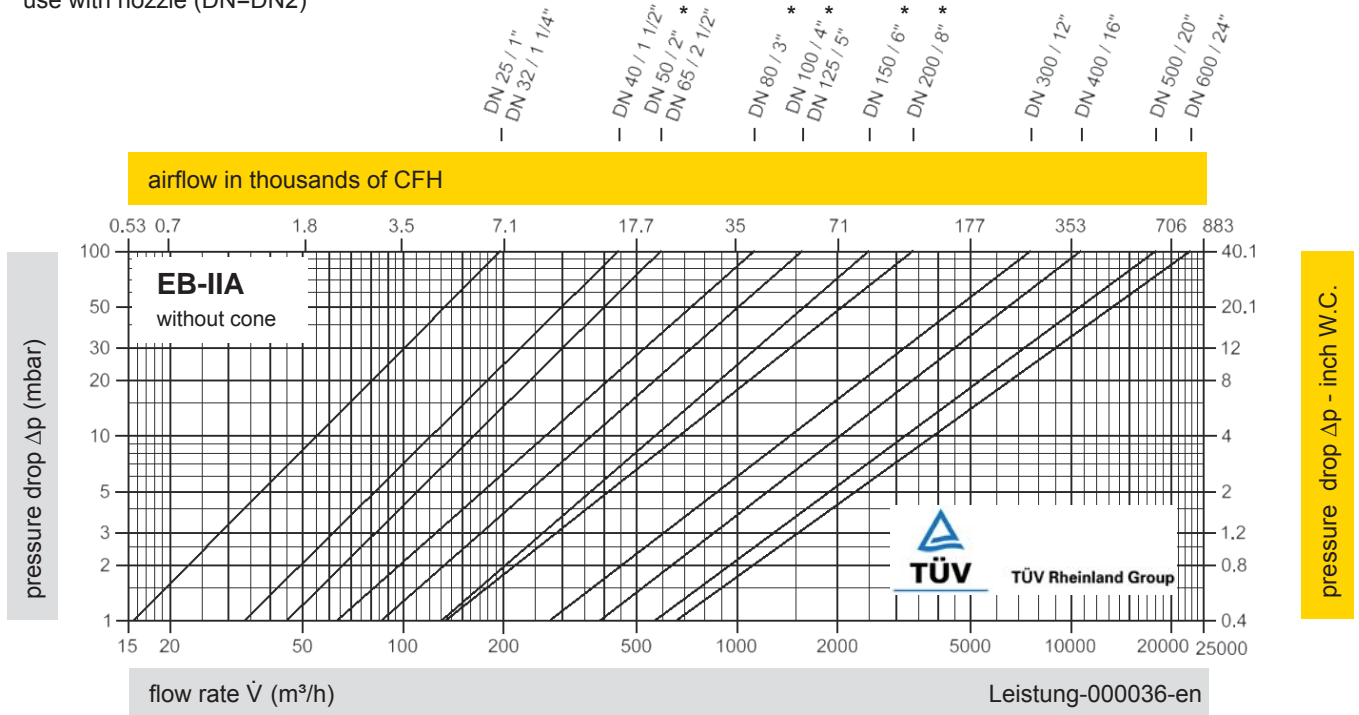

Remark: Flow capacity charts for EB-DN/DN2-IIA/IIB with cone upon request

* use with nozzle (DN=DN2)

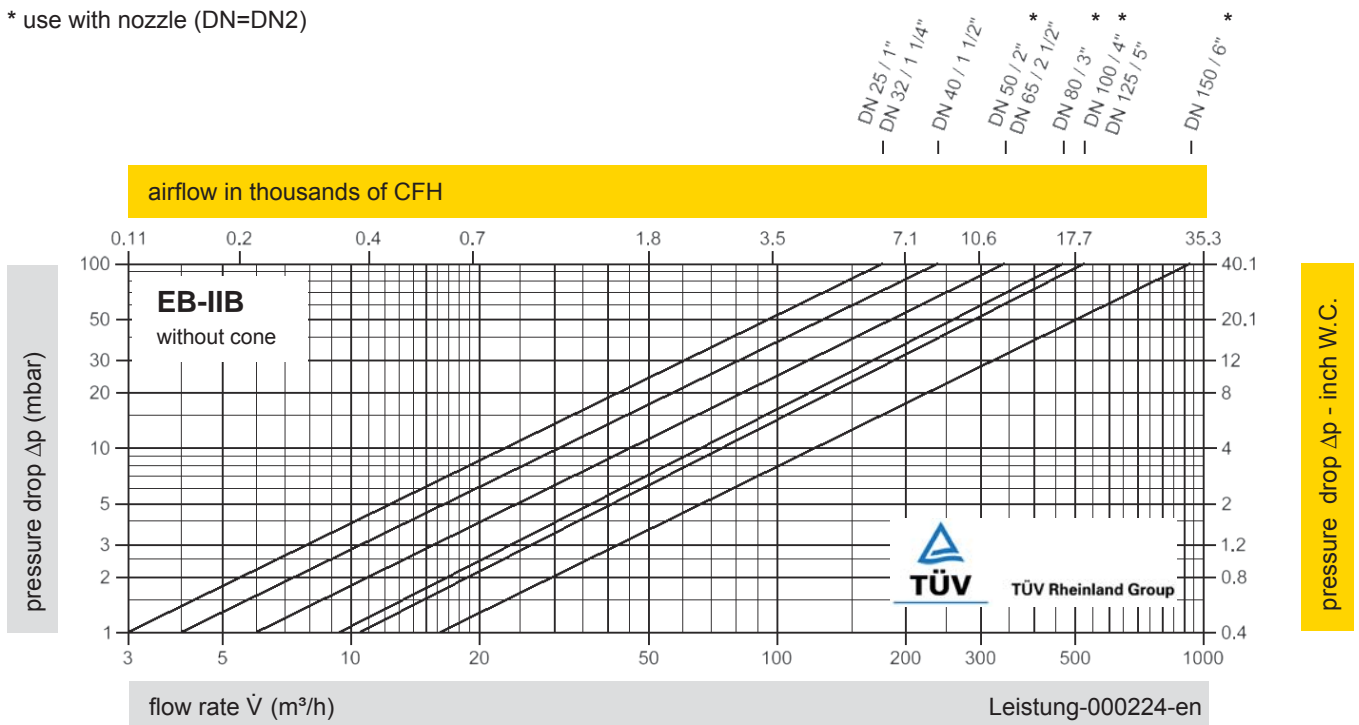

The flow capacity chart has been determined with a calibrated and TÜV certified flow capacity test rig.
Volume flow \dot{V} in (m³/h) and CFH refer to the standard reference conditions of air ISO 6358 (20°C, 1bar).
Conversion to other densities and temperatures refer to Vol. 1: "Technical Fundamentals".

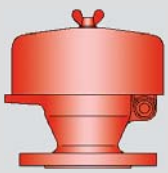

Deflagration Flame Arrester, endurance burning proof, End-of-Line

PROTEGO® BE/HK-E

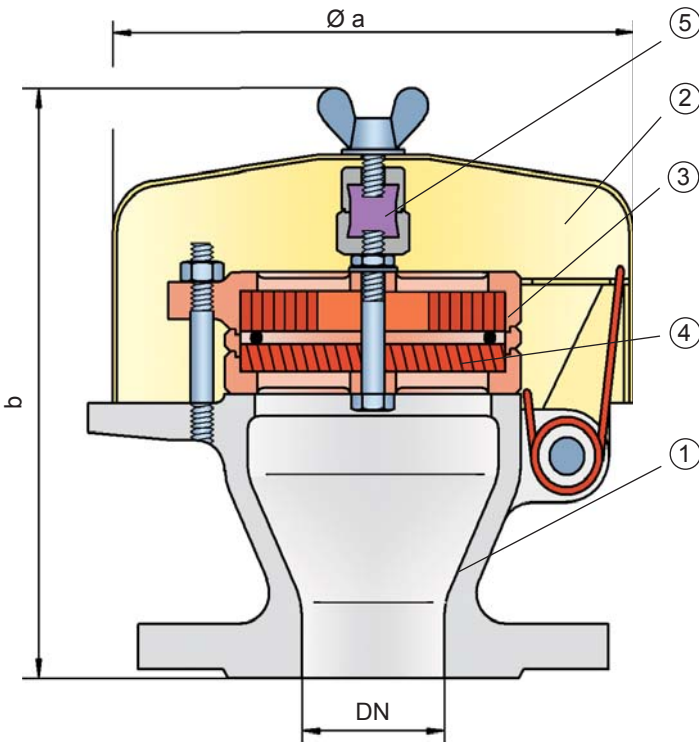

⑤ the spring loaded weather hood move into the open position. The PROTEGO® flame arrester unit consists of two FLAME-FILTER® discs (4), which are installed in a FLAMEFILTER® cage. The PROTEGO® BE/HK-E end-of-line deflagration flame arrester is available for alcohols and other substances with MESG $\geq 0,85\text{mm}$.

The standard design can be used for operating temperatures up to $+60^\circ\text{C} / 140^\circ\text{F}$.

④ Type-approved in accordance with the current ATEX Directive and EN ISO 16852 as well as other international standards.

① Special Features and Advantages

- endurance burning protection for alcohols and hydrocarbons with MESG $\geq 0,85\text{mm}$.
- weather hood protects against environmental impact (i.e. weather, bird nests, etc.)
- weather hood will open and signal the impact of a flame
- fusible link is resistant against chemicals
- modular design allows replacement of single FLAMEFILTER®
- easy maintenance
- protection against atmospheric deflagration and endurance burning
- modular design results in low spare part cost

Function and Description

The PROTEGO® BE/HK-E end-of-line deflagration flame arrester was specifically developed for vessels which are not pressurized and store Ethanol or other alcohols. The combustion of alcohol requires a modified flame arrester element design to provide protection against endurance burning. In addition, the device provides protection against atmospheric deflagration. Main application area is on in - and outbreathing and vent lines, with the goal to prevent flame transmission caused by endurance burning or atmospheric deflagration from propogating into the vessel or plant.

The PROTEGO® BE/HK-E consists of a housing (1), a weather hood (2) and the PROTEGO® flame arrester unit (3). During normal operation the metal weather hood is in a closed position. If a stabilized flame burns on the flame arrester element surface, the fusible link (5), located in a center position, will melt and let

Design Types and Specifications

There are two different designs:

End-of-line deflagration flame arrester, basic design BE/HK-E -

End-of-line deflagration flame arrester with heating jacket BE/HK-E -

Special designs available on request

Table 1: Dimensions

Dimensions in mm / inches

To select the nominal size (DN), please use the flow capacity charts on the following pages

DN	20 / ¾"	25 / 1"	32 / 1¼"	40 / 1½"	50 / 2"	65 / 2½"	80 / 3"
a	163 / 6.42	163 / 6.42	163 / 6.42	183 / 7.20	183 / 7.20	218 / 8.58	218 / 8.58
b	180 / 7.09	177 / 6.97	177 / 6.97	190 / 7.48	190 / 7.48	200 / 7.87	200 / 7.87

Dimensions for deflagration flame arrester with heating jacket upon request



Table 2: Selection of explosion group

MESG	Expl. Gr. (IEC/CEN)	Gas Group (NEC)	Special approvals upon request
≥ 0,85 mm	IIB1	–	

Table 3: Material selection for housing

Design	B	C	Special materials upon request
Housing	Steel	Stainless Steel	
Weather hood	Steel	Stainless Steel	
Flame arrester unit	A	A, B	

Table 4: Material combinations of flame arrester unit

Design	A	B	Special materials upon request
FLAMEFILTER® cage	Stainless Steel	Stainless Steel	
FLAMEFILTER®	Stainless Steel	Hastelloy	
Spacer	Stainless Steel	Hastelloy	

Table 5: Flange connection type

EN 1092-1; Form B1	other types upon request
ASME B16.5; 150 lbs RFSF	

Flow Capacity Chart

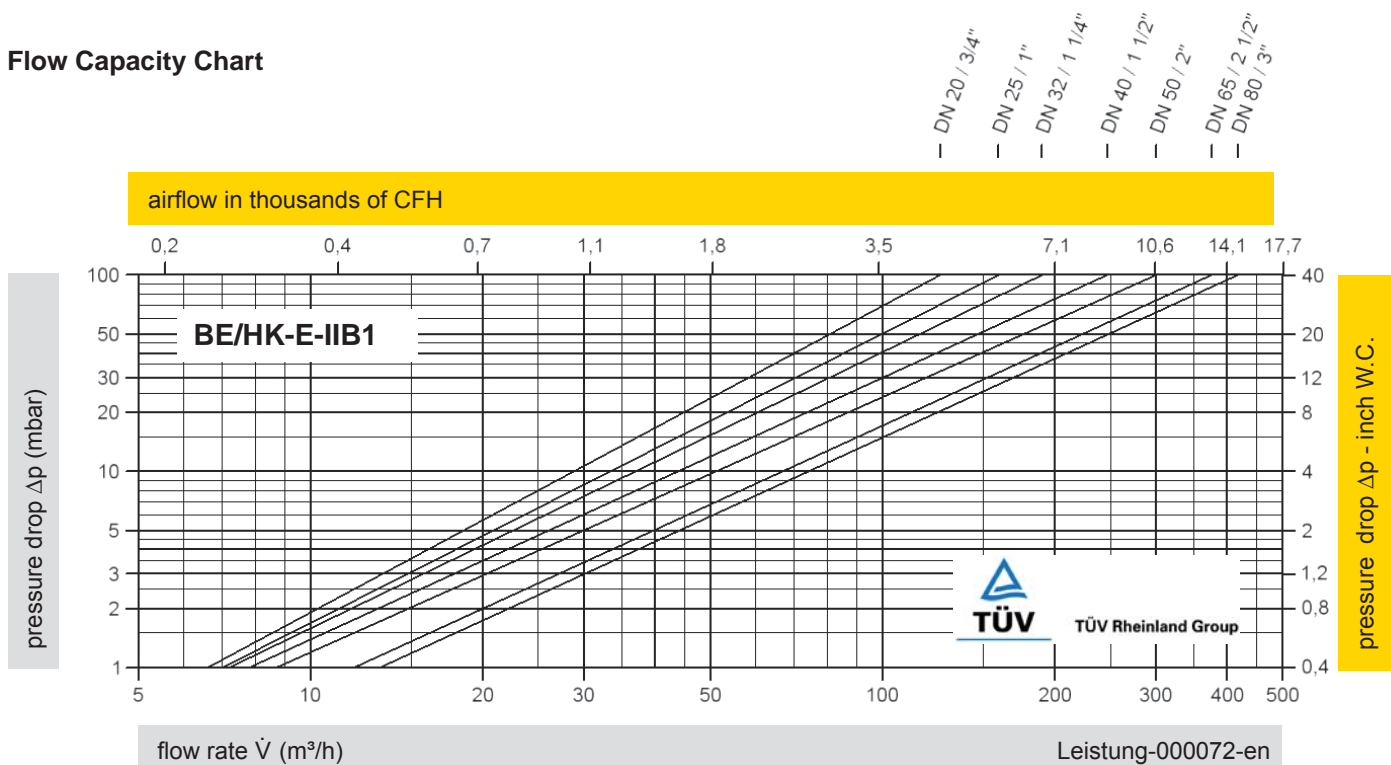

The flow capacity charts have been determined with a calibrated and TÜV certified flow capacity test rig. Volume flow \dot{V} in (m³/h) and CFH refer to the standard reference conditions of air ISO 6358 (20°C, 1bar). Conversion to other densities and temperatures refer to Vol. 1: "Technical Fundamentals".





Deflagration Flame Arrester, endurance burning proof, End-of-Line

PROTEGO® BE/HR-E

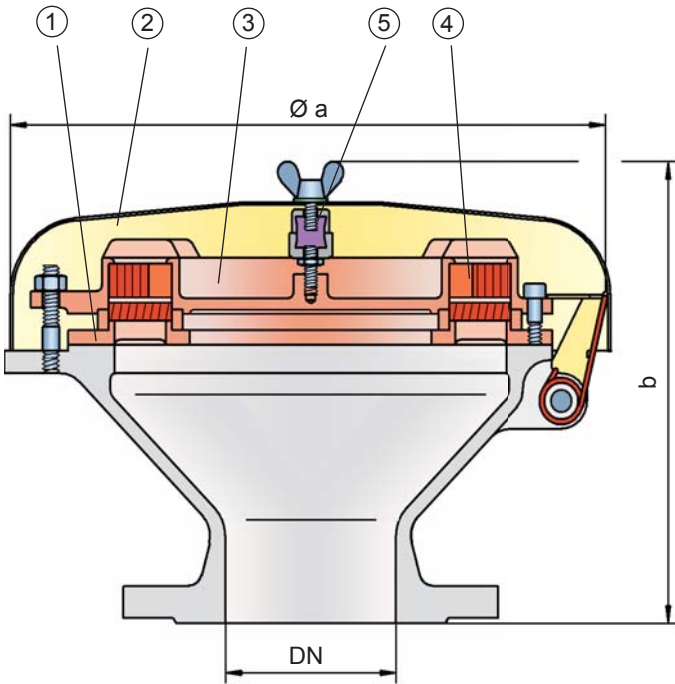

The PROTEGO® BE/HR-E end-of-line deflagration flame arrester is available for alcohols and other substances with a MESG $\geq 0,85$ mm.

The standard design can be used for operating temperatures up to $+60^{\circ}\text{C} / 140^{\circ}\text{F}$.

Type-approved in accordance with the current ATEX Directive and EN ISO 16852 as well as other international standards.

Special Features and Advantages

- endurance burning protection for alcohols and hydrocarbons with a MESG $\geq 0,85$ mm
- weather hood protects against environmental impact (i.e. weather, bird nests, etc.)
- weather hood opens and signals the impact of a flame
- fusible link is resistant against chemicals
- modular design allows replacement of single FLAMEFILTER®
- protection against atmospheric deflagration and endurance burning
- modular design results in low spare part cost

Design Types and Specifications

There are two different designs:

End-of-line deflagration flame arrester, basic design **BE/HR - E -**

End-of-line deflagration flame arrester with heating jacket **BE/HR - E -**

Special designs available on request

Function and Description

The PROTEGO® BE/HR-E end-of-line deflagration flame arrester was specifically developed for vessels which are not pressurized and store Ethanol or other alcohols with a MESG $\geq 0,85$ mm. The combustion of alcohol requires a modified flame arrester element design to provide protection against endurance burning. In addition, the device provides protection against atmospheric deflagration. Main application area is on suction and vent lines, with the goal to prevent flame transmission caused by endurance burning or atmospheric deflagration from propagating into the vessel or plant.

The PROTEGO® BE/HR-E consists of a housing (1), a weather hood (2) and the PROTEGO® flame arrester unit (3). During normal operation, the metal weather hood is in a closed position. If a flame burns on the flame arrester element surface, the fusible link (5), located in a center position, will melt and let the spring loaded weather hood move into the open position. The PROTEGO® flame arrester unit consists of two FLAMEFILTER® discs (4), which are installed in a FLAMEFILTER® cage.

Table 1: Dimensions

Dimensions in mm / inches

To select the nominal size (DN), please use the flow capacity charts on the following pages

DN	80 / 3"	100 / 4"	Dimensions for deflagration flame arrester with heating jacket upon request
a	353 / 13.90	353 / 13.90	
b	250 / 9.84	250 / 9.84	



Demonstration of endurance burning
Video

Table 2: Selection of explosion group

MESG	Expl. Gr. (IEC/CEN)	Gas Group (NEC)	
≥ 0,85 mm	IIB1	–	Special approvals upon request

Table 3: Material selection for housing

Design	B	C	
Housing	Steel	Stainless Steel	Special materials upon request
Weather hood	Steel	Stainless Steel	
Flame arrester unit	A	A, B	

Table 4: Material combinations of flame arrester unit

Design	A	B	
FLAMEFILTER® cage	Stainless Steel	Stainless Steel	Special materials upon request
FLAMEFILTER®	Stainless Steel	Hastelloy	
Spacer	Stainless Steel	Hastelloy	

Table 5: Flange connection type

EN 1092-1; Form B1	other types upon request
ASME B16.5; 150 lbs RFSP	

Flow Capacity Chart

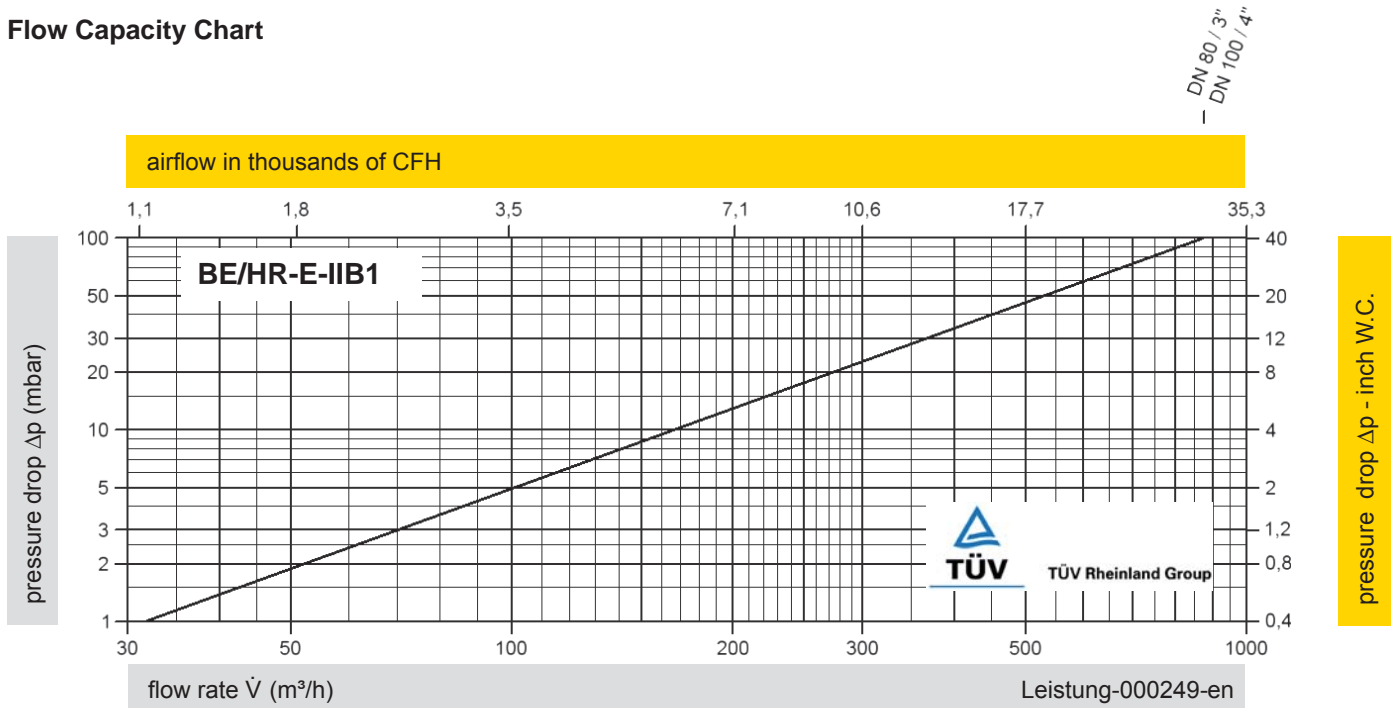

The flow capacity charts have been determined with a calibrated and TÜV certified flow capacity test rig. Volume flow \dot{V} in (m³/h) and CFH refer to the standard reference conditions of air ISO 6358 (20°C, 1bar). Conversion to other densities and temperatures refer to Vol. 1: "Technical Fundamentals".



www.protego.com



for safety and environment

PROTEGO® Deflagration Flame Arresters

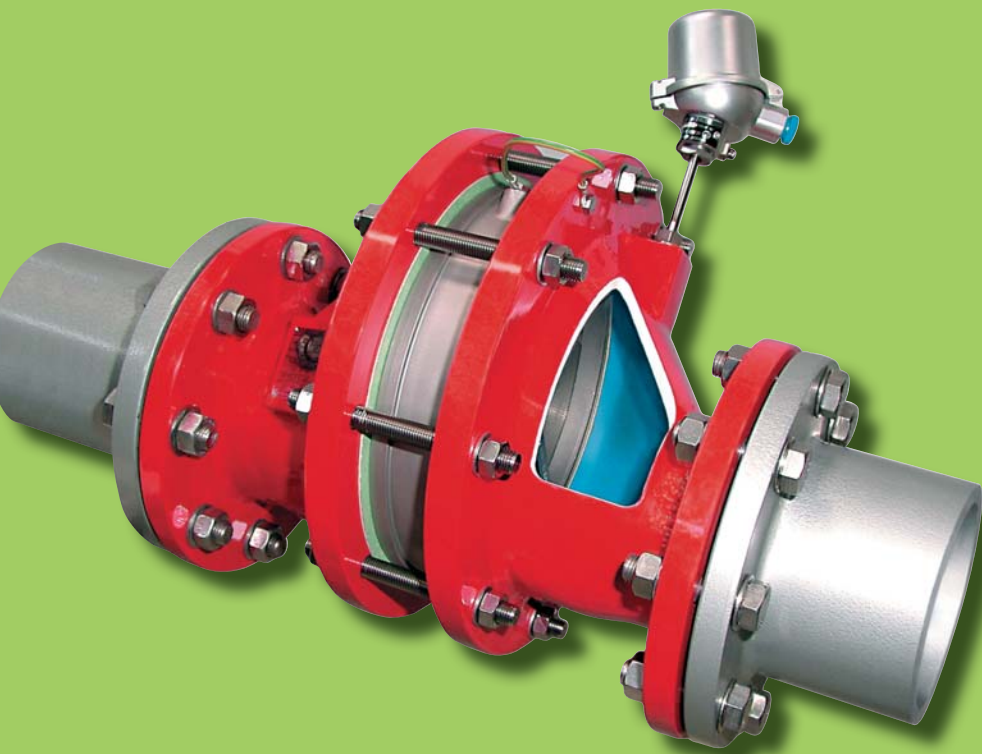

Volume 3

Volume 3



for safety and environment



Function and description

The function of flame arresters in the various combustion processes and the location of their installation is discussed in “Technical Fundamentals” (see Vol. 1). In this chapter, we present PROTEGO® in-line **deflagration flame arresters which are installed in pipelines and as components on equipment (e.g. blowers, vacuum pumps)**.

With the goal of protecting process units PROTEGO® deflagration flame arresters are state-of-the-art safety devices that are used in systems handling explosive mixtures to mitigate deflagrations. They reliably suppress the effect of a deflagration in the pipelines near a potential ignition source, extinguish the flame, and protect systems that cannot withstand the pressure of an explosion. In cases where a stable flame can continue on the flame arrester element, in-line deflagration flame arresters only provide protection for a limited time. If this time can be exceeded, an additional measure has to be provided for mixtures that continue to flow continuously.

The main component is the PROTEGO® flame arrester unit (1), which takes the energy from the deflagration and extinguishes the flame in narrow gaps. The flame arrester unit is modular, consisting of several FLAMEFILTER® discs (2) installed within the FLAMEFILTER® cage (3). The number of FLAMEFILTER® discs and their gap size depend on the devices intended use and depend on process parameters such as temperature, pressure, vapour group of the handled gases.

① PROTEGO® flame arrester unit

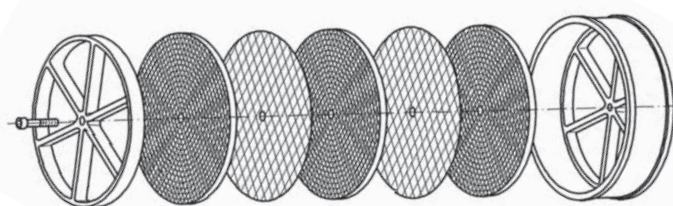

②

③

Deflagration flame arresters in pipelines for protection of process units can only be used if approved for such application. The distance from the potential ignition source is limited and is expressed by $(L/D)_{max}$ for the individual device. A fire may result on the flame arrester unit if the mixture continues to flow. As the deflagration flame arrester is only approved for a specific time period, the device should be equipped with a temperature sensor to detect temperature increase caused by a flame. Should the temperature increase over a certain level, a suitable measure such as nitrogen purging should be used.

As a component of equipment, deflagration flame arresters are type-tested and approved along with the equipment (OEM part, e.g. vacuum pumps, blowers). They are not available separately as independent deflagration flame arresters.

A broad variety of types, designs, nominal diameters and materials are available. In addition, we are able to develop customized solutions for our clients at our state-of-the-art test facility, which is the largest privately owned research center in flame arrester business worldwide.

Special features and advantages

The devices can be distinguished and selected based on the following main criteria: **Components for equipment** (e.g. blowers, vacuum pumps) or **devices to be installed in pipelines** handling gas or vapour. Special operating conditions (e.g. **elevated operating pressures or temperatures**) that go beyond classified values of different test standards may have to be considered.

It is important to categorize the products or components into **explosion groups**, depending on their MESHG, to select the suitable type of protection from the various designs.

The suitable or required **approved device** must be selected from the great variety of devices that have been tested and approved.

The basic **designs** of the housing are **concentric, eccentric** and with a “easy access cover” for simple disassembly of the flame arrester unit.

The system specification must be considered when choosing the required **nominal diameters** and types of connection.

A **heating jacket** may be necessary for problematic applications.

Special designs offering **unidirectional or bidirectional** protection can be provided as well as versions for **critical fluids (such as products that tend to polymerize or crystallize)** and special product properties.

Deflagration arresters as specific components for OEM equipment (e.g. blowers or vacuum pumps) are specifically optimized and tested along with the equipment.

Preferred applications

Protection of pipelines; containers in chemical, petrochemical, and pharmaceutical processing systems; loading systems; gas collection systems; exhaust combustion systems; flare systems; landfills and biogas systems and sewage treatment plants.



In-line deflagration test
The Flame Arrester reliably stops
the explosion (Video)



In-line deflagration test without
working Flame Arrester
(Video)

Installation and servicing

PROTEGO® deflagration flame arresters are preferably installed as close as possible to the potential ignition source. Typically any orientation of installation can be chosen, but the direction of flow needs to be taken into account for designs with temperature sensors. No pipes with a nominal diameter greater than the nominal diameter of the device shall be connected to the deflagration flame arrester.

Given the modular design of the PROTEGO® flame arrester unit, any type of deflagration flame arrester is extremely easy to service. For servicing reasons, the location of the flame arrester must be planned to be very accessible; a hoist must be provided if the flame arrester is heavy. Servicing is easy for trained personnel.

PROTEGO® deflagration flame arresters are used in areas subject to explosion hazards. Devices have to be selected that match the intended use. The manufacturer's certificate of conformity provides the boundary conditions for which the device is suitable. The user has to document proper use in accordance with applicable safety guidelines or standards.

Selection

The following main points should be considered for choosing the correct device for your application:

- **In-line flame arrester or component on equipment** (e.g. vacuum pump or blower)
- **Explosion group** of gas mixture
- Standard or special operating conditions (**pressure and temperature**)

Finally, the following criteria are reviewed and considered

- **Nominal diameter** and type of connection
- **Approvals** according to ATEX, Gost-R, GL, etc..
- **Concentric or eccentric design** or designed with an easy access cover
- **Heating jacket or heating coil**
- **Critical fluids**
- **Unidirectional or bidirectional** protection

Based on this initial selection, the additional details such as materials, coatings, etc. can be requested or specified.

If no suitable device can be selected, please contact us. Special designs and approvals are available upon request.

Sizing

The nominal diameter of the device is determined or checked in the p/\dot{V} performance diagram. A safety factor must be considered when the fluid has a tendency to clog the flame arrester element.

- Given:** Volume flow m^3/h or CFH
- Given:** Max. all. pressure drop Δp mbar or inch W.C.
- Desired:** Nominal diameter of the deflagration flame arrester DN
- Procedure:** Intersection of the lines with volume flow and maximum allowable pressure drop lies above or on the desired nominal diameter curve of the device
- Given:** Volume flow m^3/h or CFH
- Given:** Nominal diameter of pipe DN
- Desired:** Pressure drop Δp mbar or inch W.C.
- Procedure:** Intersection of the lines with the volume flow and nominal diameter curve of the device, horizontal straight line leads to the desired flow resistance

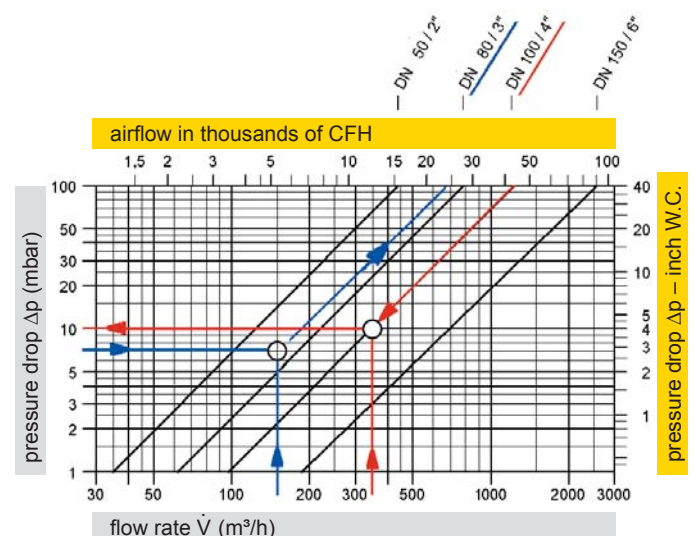







Instructions on calculating the volume flow or influence of density are found in Technical Fundamentals (Vol. 1).

After all the steps are complete, the device can be specified and ordered.

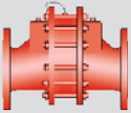
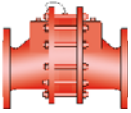
For special cases, please fill out the questionnaire with the process data in Vol. 1, that will serve as information for providing a quote.

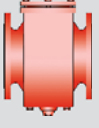

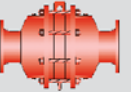
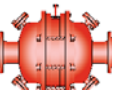
PROTEGO® Deflagration Flame Arrester

	Type	Size DN	Design cc = concentric ec = eccentric	Explosion-group		Approvals	Special designs for higher temperatures and pressures	Special designs for critical medium (polymerisation, corrosion, crystallisation)	unidirectional bidirectional	Page
				ATEX	NEC					
In-line deflagration flame arrester										
	FA-E	25 - 300 1" - 12"	straight through, ec	IIA1 (I)	-	ATEX	○	○	X	
	FA-E	25 - 300 1" - 12"	straight through, ec	IIA, IIB3, IIC	D, C, B	ATEX	○	○	X	90 - 95
	FA-CN	40 - 300 1½" - 12"	straight through, cc	IIA1 (I)	-	ATEX	○		X	
	FA-CN	25 - 300 1" - 12"	straight through, cc	IIA, IIB3	D, C	ATEX	○		X	96 - 99
	FA-CN	40 - 300 1½" - 12"	straight through, cc	IIC	B	ATEX			X	100 - 102
	FA-G	G ½ - G 2	straight through, cc	IIA, IIB3, IIC	D, C, B	ATEX	○		X	104 - 107
	FA-I	50 - 1000 2" - 40"	straight through, cc	IIA, IIB3	D, C	ATEX	○	○	X	108 - 111
	FA-I-PTFE	50 - 150 2" - 6"	straight through, cc	IIA	D	ATEX		○	X	

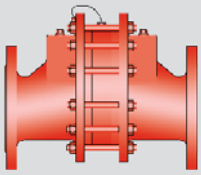

In-Line Deflagration Flame Arrester

eccentric design,
bidirectional

PROTEGO® FA-E

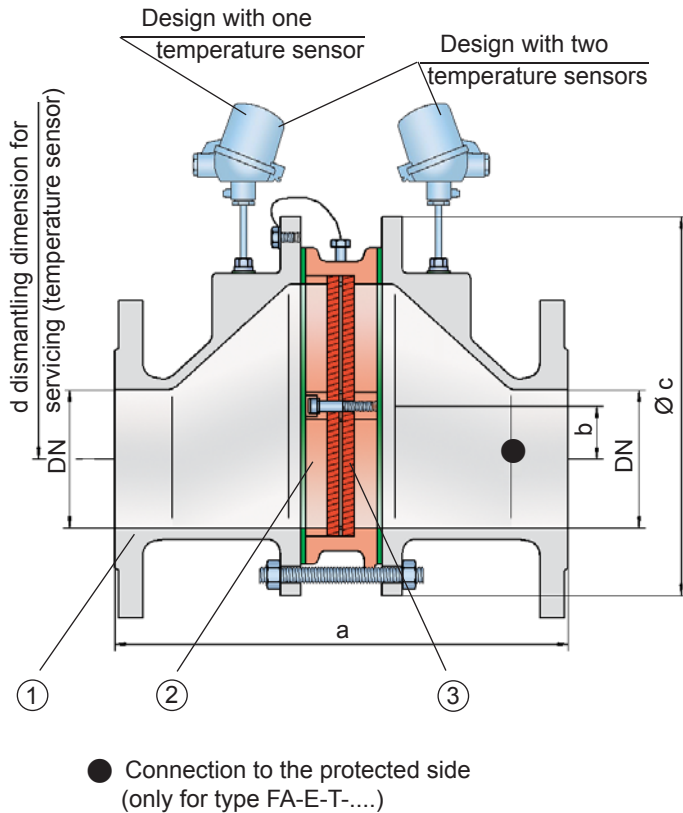

● Connection to the protected side
(only for type FA-E-T-....)

Function and Description

The PROTEGO® FA-E series of in-line deflagration flame arresters is designed with an eccentric housing to automatically drain condensate build up in the housing. Due to its eccentric design the device can be installed in pipelines that run close to floors or walls and low points, where condensate can collect within the piping system, can be avoided. When installing the deflagration flame arrester, make sure that the distance between potential ignition sources and the location of the installed device, does not exceed the L/D ratio (pipe length/pipe diameter), for which the device was approved. According to EN ISO 16852 the installation limits are $(L/D)_{max} \leq 50$ for deflagration flame arresters of explosion groups IIA and IIB3 (NEC groups D to C) and $(L/D)_{max} \leq 30$ for explosion group IIC (NEC group B).

The devices are symmetrical and offer bidirectional flame transmission protection. The arrester essentially consists of two housing parts (1) and a PROTEGO® flame arrester unit (2) in the center. The PROTEGO® flame arrester unit is modular and consists of several FLAMEFILTER® discs (3) and spacers firmly held in a FLAMEFILTER® cage. The number of FLAMEFILTER® and their gap size depends arrester's conditions of use.

By indicating the operating parameters such as temperature, pressure, explosion group and the composition of the fluid, the optimum deflagration flame arrester can be selected from a series of approved devices. The PROTEGO® FA-E series of deflagration flame arresters is available for substances from explosion groups IIA to IIC (NEC groups D to B).

The standard design can be used up to an operating temperature of +60°C / 140°F and an absolute operating pressure up to 1.1 bar / 15.9 psi. **Devices with special approval can be obtained for higher pressures (see table 3) and higher temperatures upon request.**

Type-approved in accordance with the current ATEX Directive and EN ISO 16852 as well as other international standards.

Special Features and Advantages

- eccentric design prevents condensate build up
- special design for elevated operating temperatures and pressures available
- modular design enables each individual FLAMEFILTER® to be replaced
- service friendly: FLAMEFILTER® can be cleaned easily
- eccentric design eases installation close to floors and walls
- bidirectional flame transmission proof design
- protects against deflagrations for all explosion groups IIA, IIB3 and IIC (NEC groups D, C and B)
- modular design reduces spare parts cost

Design and Specifications

There are three different designs:

Basic in-line deflagration flame arrester **FA-E - [-]**

In-line deflagration flame arrester with integrated temperature sensor* as additional protection against short-time burning from one side **FA-E - [T]**

In-line deflagration flame arrester with two integrated temperature sensors* for additional protection against short-time burning from both sides **FA-E - [TB]**

Additional special devices available upon request

*Resistance thermometer for device group II, category (1) 2 (GII cat. (1) 2)



Stabilized FLAMEFILTER®
Discs (Flyer pdf)



New PROTEGO® Flame Arrester Unit unique
maintenance friendly design (Flyer pdf)



L/D ratio (Flyer pdf)

Table 1: Dimensions

Dimensions in mm / inches

To select the nominal size (DN), use the flow capacity charts on the following pages

Expl. Gr.	DN	25 / 1"	32 / 1¼"	40 / 1½"	50 / 2"	65 / 2½"	80 / 3"	100 / 4"	125 / 5"	150 / 6"	200 / 8"	250 / 10"	300 / 12"
IIA	a	304 / 11.97	304 / 11.97	310 / 12.20	314 / 12.36	360 / 14.17	364 / 14.33	370 / 14.57	434 / 17.09	440 / 17.32	450 / 17.72	480 / 18.90	500 / 19.69
IIB3	a	304 / 11.97	304 / 11.97	310 / 12.20	314 / 12.36	360 / 14.17	364 / 14.33	370 / 14.57	434 / 17.09	440 / 17.32	450 / 17.72	480 / 18.90	500 / 19.69
IIC	a	304 / 11.97	304 / 11.97	321 / 12.64	325 / 12.80	371 / 14.61	375 / 14.76	381 / 15.00	445 / 17.52	451 / 17.76	461 / 18.15	491 / 19.33	511 / 20.12
	b	29 / 1.14	29 / 1.14	29 / 1.14	29 / 1.14	38 / 1.49	38 / 1.49	39 / 1.53	65 / 2.56	65 / 2.56	55 / 2.17	58 / 2.28	60 / 2.36
	c	185 / 7.28	185 / 7.28	210 / 8.27	210 / 8.27	250 / 9.84	250 / 9.84	275 / 10.83	385 / 15.16	385 / 15.16	450 / 17.72	500 / 19.69	575 / 22.64
	d	400 / 15.75	400 / 15.75	410 / 16.14	410 / 16.14	440 / 17.32	440 / 17.32	460 / 18.11	520 / 20.47	520 / 20.47	540 / 21.26	570 / 22.44	600 / 23.62

Table 2: Selection of the explosion group

MESG	Expl. Gr. (IEC/CEN)	Gas Group (NEC)	Special approvals upon request
> 0.90 mm	IIA	D	
≥ 0.65 mm	IIB3	C	
< 0.50 mm (> 0.50 mm)	IIC (IIB)	B	

Table 3: Selection of max. operating pressure

Expl. Gr.	DN	25 / 1"	32 / 1¼"	40 / 1½"	50 / 2"	65 / 2½"	80 / 3"	100 / 4"	125 / 5"	150 / 6"	200 / 8"	250 / 10"	300 / 12"
IIA	P _{max}	1.6 / 23.2	1.6 / 23.2	1.6 / 23.2	1.6 / 23.2	1.6 / 23.2	1.6 / 23.2	1.6 / 23.2	1.6 / 23.2	1.6 / 23.2	1.6 / 23.2	1.6 / 23.2	1.6 / 23.2
IIB3	P _{max}	1.6 / 23.2	1.6 / 23.2	1.6 / 23.2	1.6 / 23.2	1.6 / 23.2	1.6 / 23.2	1.6 / 23.2	1.6 / 23.2	1.6 / 23.2	1.6 / 23.2	1.6 / 23.2	1.6 / 23.2
IIC	P _{max}	1.1 / 15.9	1.1 / 15.9	1.1 / 15.9	1.1 / 15.9	1.1 / 15.9	1.1 / 15.9	1.2 / 17.4	1.1 / 15.9	1.1 / 15.9	1.1 / 15.9	1.1 / 15.9	1.1 / 15.9

P_{max} = maximum allowable operating pressure in bar / psi absolute, higher operating pressure upon request

Table 4: Specification of max. operating temperature

≤ 60°C / 140°F	Tmaximum allowable operating temperature in °C	higher operating temperatures upon request
-	Designation	

Table 5: Material selection for housing

Design	B	C	D	The housing can also be delivered in carbon steel with an ECTFE coating. Special materials upon request
Housing	Steel	Stainless Steel	Hastelloy	
Gasket	PTFE	PTFE	PTFE	
Flame arrester unit	A,C	C	D	

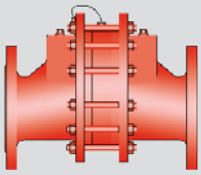

In-Line Deflagration Flame Arrester

eccentric design,
bidirectional

PROTEGO® FA-E

Table 6: Material combinations of the flame arrester unit

Design	A	C	D
FLAMEFILTER® cage	Steel	Stainless Steel	Hastelloy
FLAMEFILTER® *	Stainless Steel	Stainless Steel	Hastelloy
Spacers	Stainless Steel	Stainless Steel	Hastelloy

*the FLAMEFILTER® is also available in the materials Tantalum, Inconel, Copper, etc. when the listed housing and cage materials are used.
Special materials upon request.

Table 7: Flange connection type

EN 1092-1; Form B1	other types upon request
ASME B16.5; 150 lbs RFSF	

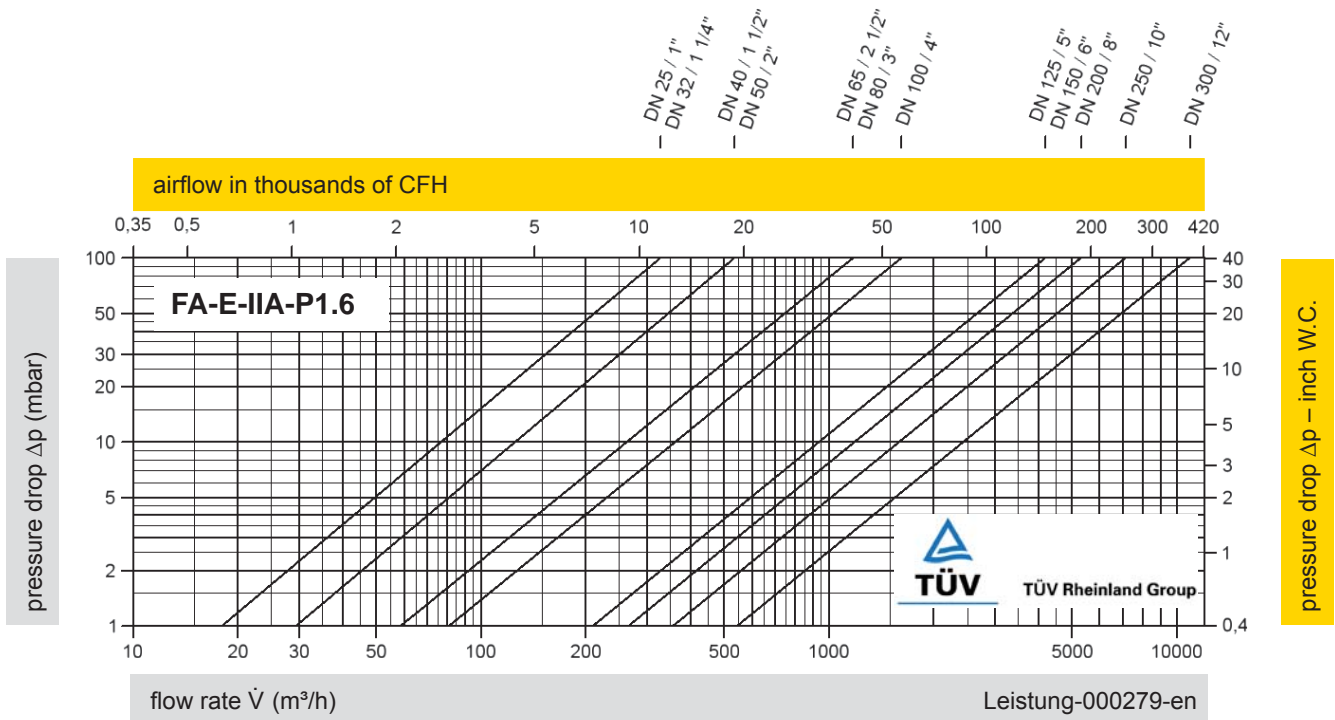
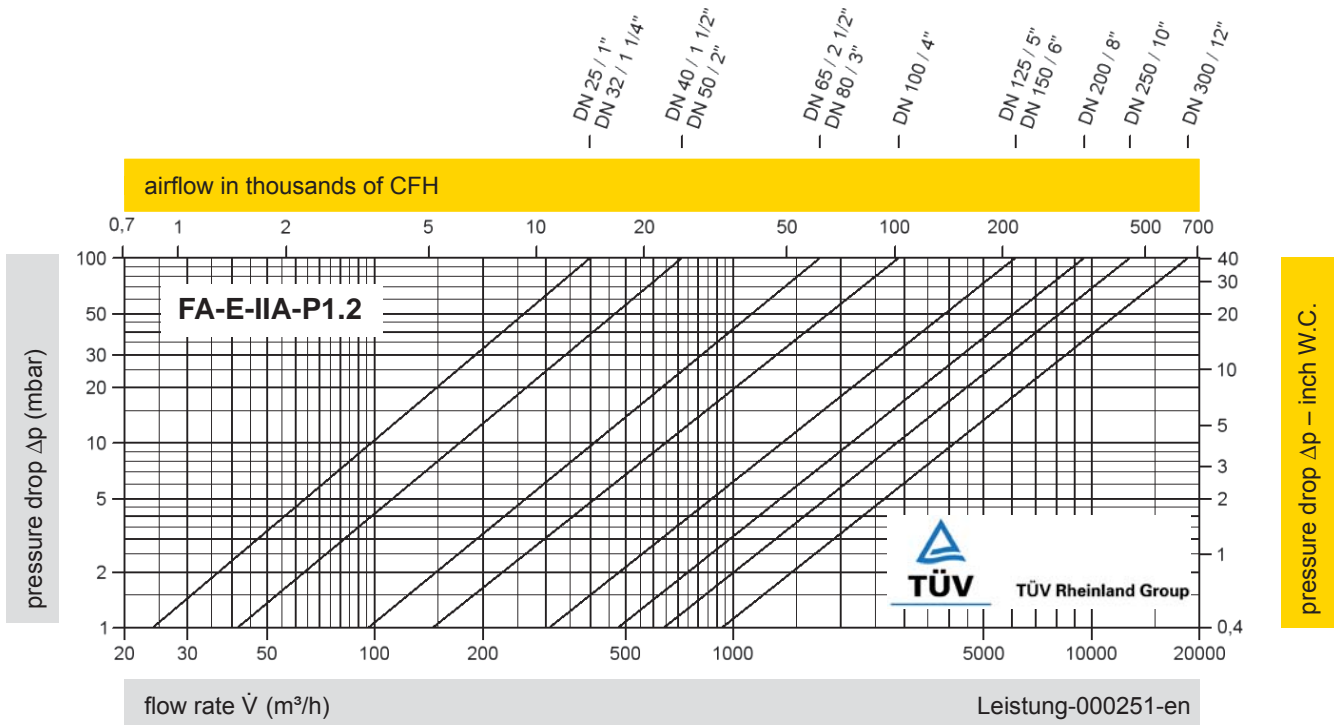

The flow capacity charts have been determined with a calibrated and TÜV certified flow capacity test rig. Volume flow \dot{V} in (m³/h) and CFH refer to the standard reference conditions of air ISO 6358 (20°C, 1bar). Conversion to other densities and temperatures refer to Vol. 1: "Technical Fundamentals".



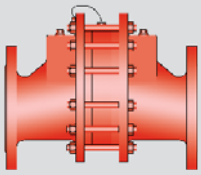

In-Line Deflagration Flame Arrester

Flow Capacity Charts

PROTEGO® FA-E

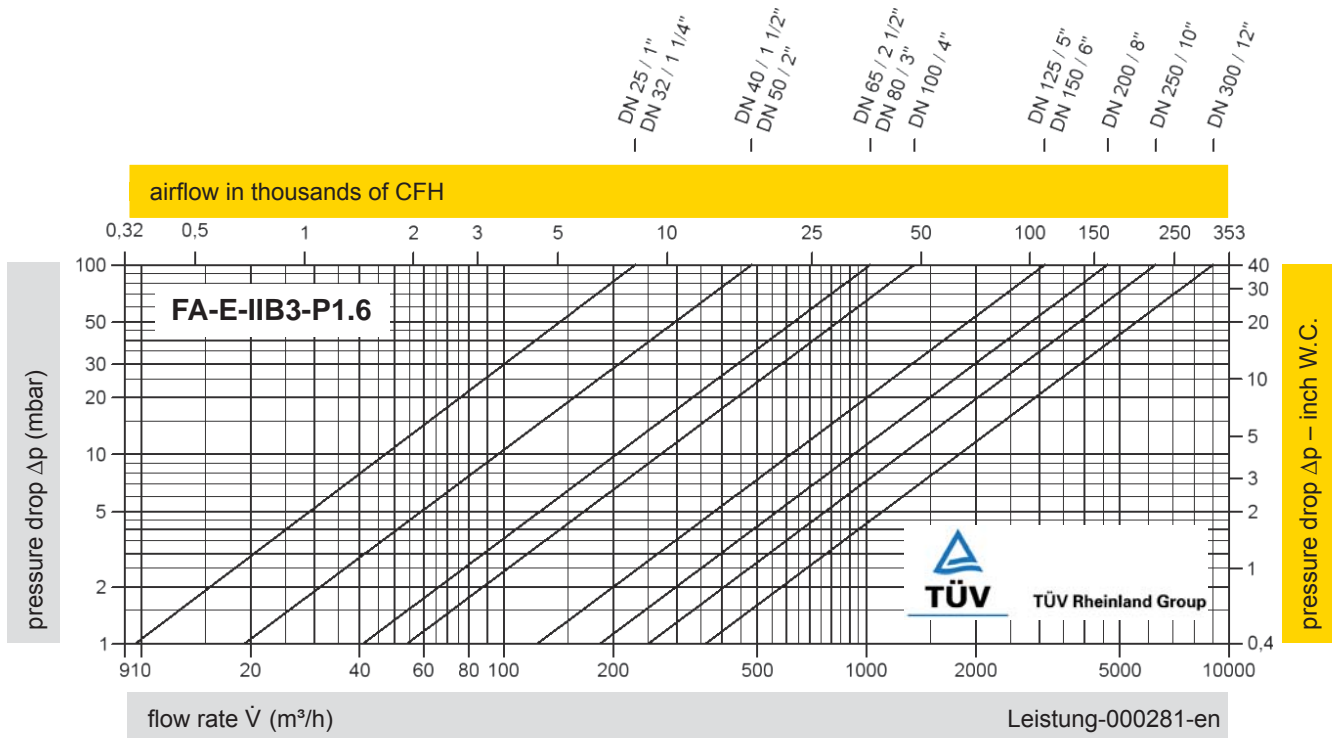
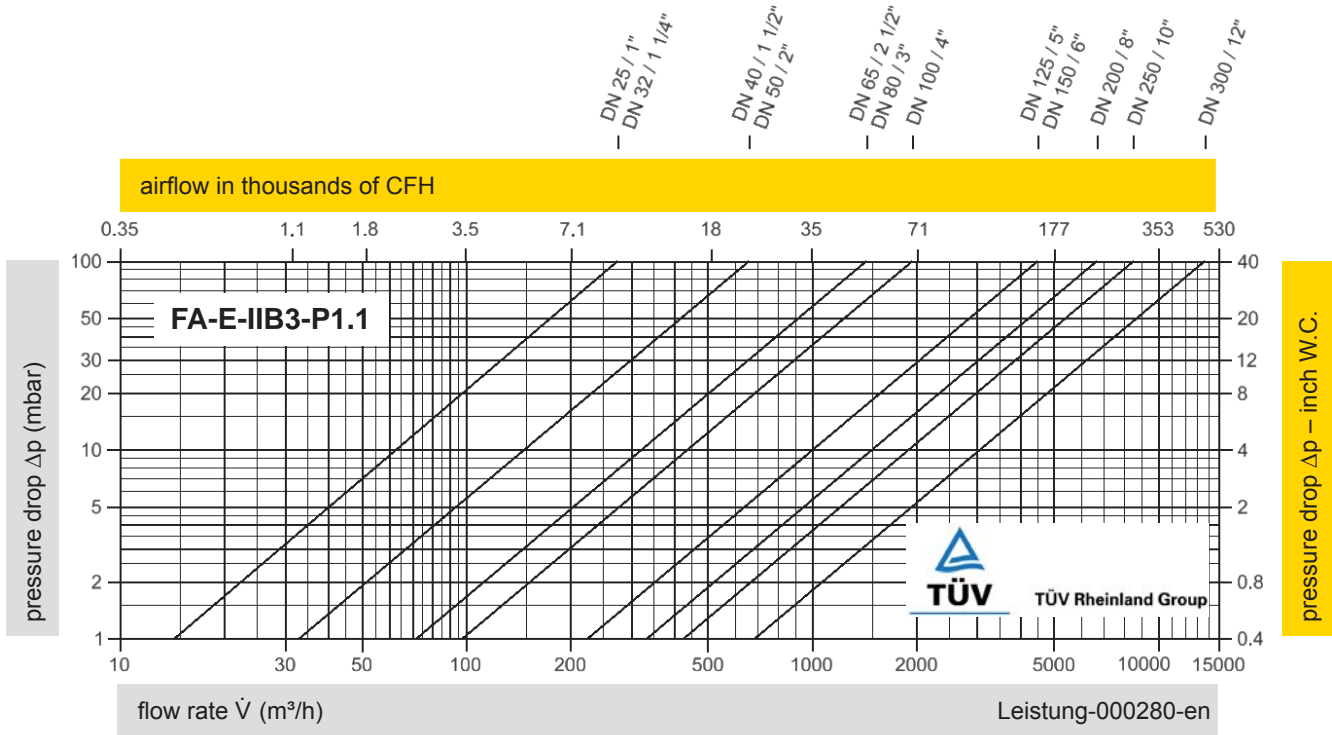

The flow capacity charts have been determined with a calibrated and TÜV certified flow capacity test rig.
 Volume flow \dot{V} in (m³/h) and CFH refer to the standard reference conditions of air ISO 6358 (20°C, 1bar).
 Conversion to other densities and temperatures refer to Vol. 1: "Technical Fundamentals".

* P1.2

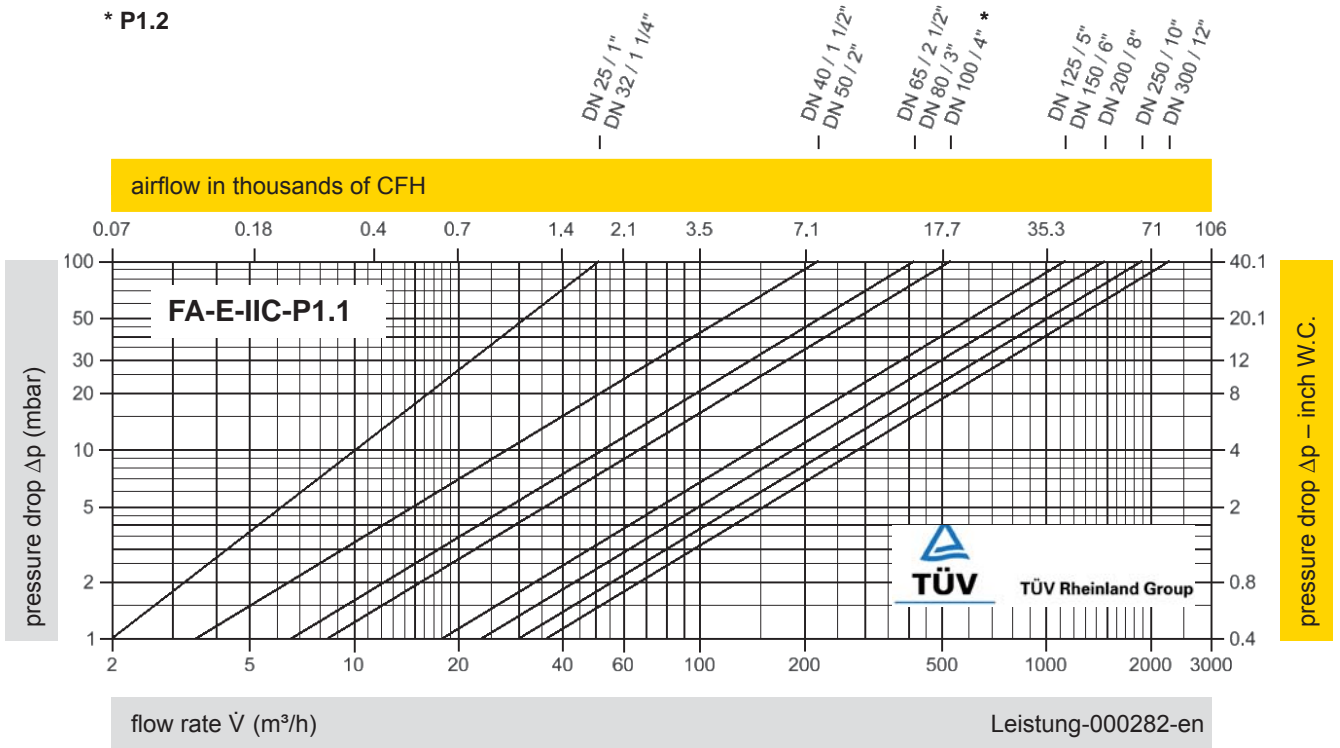

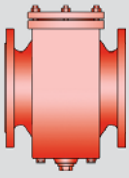

In-Line Deflagration Flame Arrester

concentric design,
bidirectional

PROTEGO® FA-CN-IIA and IIB3

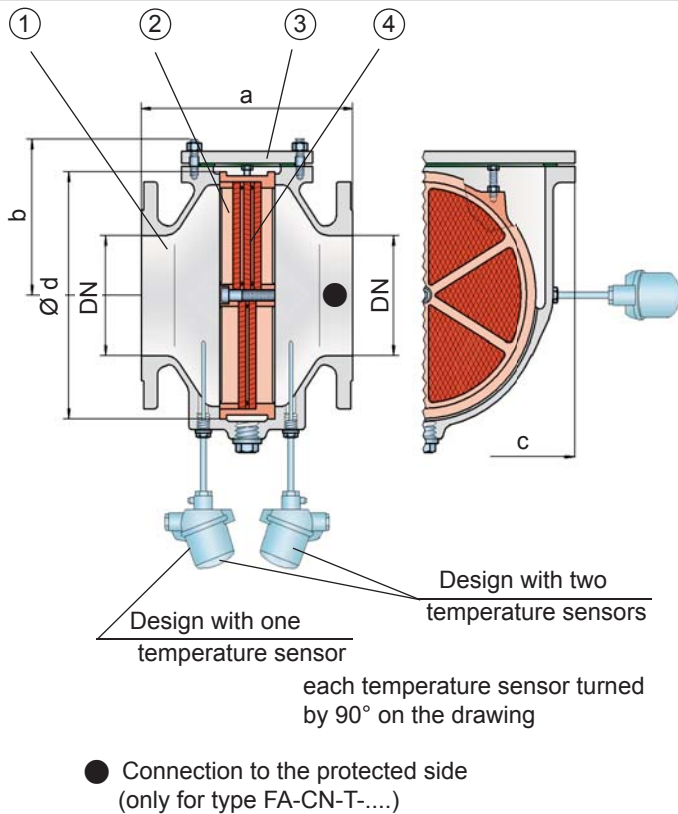

The standard design can be used up to an operating temperature of +60°C / 140°F and an absolute operating pressure up to 1.1 bar / 15.9 psi. **Devices with special approval can be obtained for higher pressures (see table 3) and higher temperatures upon request.**

Type-approved in accordance with the current ATEX Directive and EN ISO 16852 as well as other international standards.

Special Features and Advantages

- design available for elevated operating temperatures and pressures
- compact design with easy access cover
- easy maintenance without disassembling of the pipeline
- modular flame arrester unit enables individual FLAMEFILTER® to be replaced and cleaned
- bidirectional flame transmission proof design
- provides protection against deflagrations for group IIA and IIB3 vapours (NEC group D and C)
- lowest pressure drop results in low operating and lifecycle costs
- modular design reduces spare parts cost

Function and Description

The PROTEGO® FA-CN in-line deflagration flame arrester is a compact design utilizing an easy access cover for easy maintainability. The PROTEGO® flame arrester unit can be removed and cleaned within moments without having to disassemble the pipe. When installing the deflagration flame arrester, make sure that the distance between potential ignition sources and the location of the installed device, does not exceed the L/D ratio (pipe length/pipe diameter), for which the device was tested. According to EN ISO 16852 this device is approved for a (L/D)_{max} ratio of 50.

The deflagration flame arrester is symmetrical and offers bidirectional flame transmission protection. The device consists of a housing (1) with an easy access cover (3) and the PROTEGO® flame arrester unit (2) in the center. The PROTEGO® flame arrester unit is modular and consists of several FLAMEFILTER® discs (3) and spacers firmly held in a FLAMEFILTER® cage. The number of FLAMEFILTER® discs and their gap size depend on the devices intended use.

Providing the operating conditions such as the temperature, pressure, explosion group and the composition of the fluid, enables PROTEGO® to select the best deflagration flame arrester for your application. This version of PROTEGO® FA-CN-IIA and IIB3 flame arrester protects against deflagrations of fuel/air mixtures of explosion groups IIA and IIB 3 (NEC D and C (MESG ≥ 0.65 mm)). PROTEGO® FA-CN devices for substances of explosion groups IIA1 and IIC (NEC group B) are shown on separate pages.

Design and Specifications

There are three different designs:

Basic in-line deflagration flame arrester **FA-CN - []**

In-line deflagration flame arrester with integrated temperature sensor* as additional protection against short time burning from one side **FA-CN - [T]**

In-line deflagration flame arrester with two integrated temperature sensors* for additional protection against short-time burning from both sides **FA-CN - [TB]**

Additional special devices available upon request

*Resistance thermometer for device group II, category (1) 2 (GII cat. (1) 2)



Stabilized FLAMEFILTER®
Discs (Flyer pdf)



L/D ratio (Flyer pdf)

Table 1: Dimensions

Dimensions in mm / inches

To select the nominal size (DN), use the flow capacity charts on the following pages

DN	25 / 1"	32 / 1¼"	40 / 1½"	50 / 2"	65 / 2½"	80 / 3"	100 / 4"	125 / 5"	150 / 6"	200 / 8"	250 / 10"	300 / 12"
a	200 / 7.87	200 / 7.87	210 / 8.27	215 / 8.46	235 / 9.25	240 / 9.45	265 / 10.43	305 / 12.01	310 / 12.20	300 / 11.81	320 / 12.60	350 / 13.78
b	92 / 3.62	92 / 3.62	105 / 4.13	105 / 4.13	132 / 5.2	132 / 5.2	150 / 5.91	197 / 7.75	197 / 7.75	220 / 8.66	260 / 10.24	295 / 11.61
c	175 / 6.89	175 / 6.89	200 / 7.87	200 / 7.87	260 / 10.24	260 / 10.24	308 / 12.13	415 / 16.34	415 / 16.34	446 / 17.56	520 / 20.47	600 / 23.62
d	105 / 4.13	105 / 4.13	130 / 5.12	130 / 5.12	185 / 7.28	185 / 7.28	220 / 8.66	310 / 12.20	310 / 12.20	355 / 13.98	420 / 16.54	490 / 19.29

Table 2: Selection of the explosion group

MESG	Expl. Gr. (IEC/CEN)	Gas Group (NEC)	Special approvals upon request
> 0.90 mm	IIA	D	
≥ 0.65 mm	IIB3	C	

Table 3: Selection of max. operating pressure

Expl. Gr.	DN	25 / 1"	32 / 1¼"	40 / 1½"	50 / 2"	65 / 2½"	80 / 3"	100 / 4"	125 / 5"	150 / 6"	200 / 8"	250 / 10"	300 / 12"	n
IIA	P _{max}	1.6 / 23.2	1.6 / 23.2	1.6 / 23.2	1.6 / 23.2	1.6 / 23.2	1.6 / 23.2	1.5 / 21.8	1.5 / 21.8	1.5 / 21.8	1.3 / 18.9	1.3 / 18.9	1.3 / 18.9	3
IIB3	P _{max}	1.6 / 23.2	1.6 / 23.2	1.6 / 23.2	1.6 / 23.2	1.6 / 23.2	1.6 / 23.2	1.6 / 23.2	1.6 / 23.2	1.6 / 23.2	1.6 / 23.2	1.6 / 23.2	1.6 / 23.2	3

P_{max} = maximum allowable operating pressure in bar / psi absolute, higher operating pressure upon request
n = number of FLAMEFILTER®

Table 4: Specification of max. operating temperature

≤ 60°C / 140°F	T _{maximum allowable operating temperature in °C}	higher operating temperatures upon request
-	Designation	

Table 5: Material selection

Design	A	B	Special materials upon request
Housing	Steel	Stainless Steel	
Cover	Steel	Stainless Steel	
Gasket	PTFE	PTFE	
Flame arrester unit	Stainless Steel	Stainless Steel	

Table 6: Flange connection type

EN 1092-1; Form B1	other types upon request
ASME B16.5; 150 lbs RF5F	



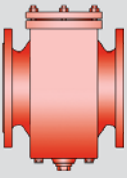

In-Line Deflagration Flame Arrester

Flow Capacity Charts

PROTEGO® FA-CN-IIA and IIB3

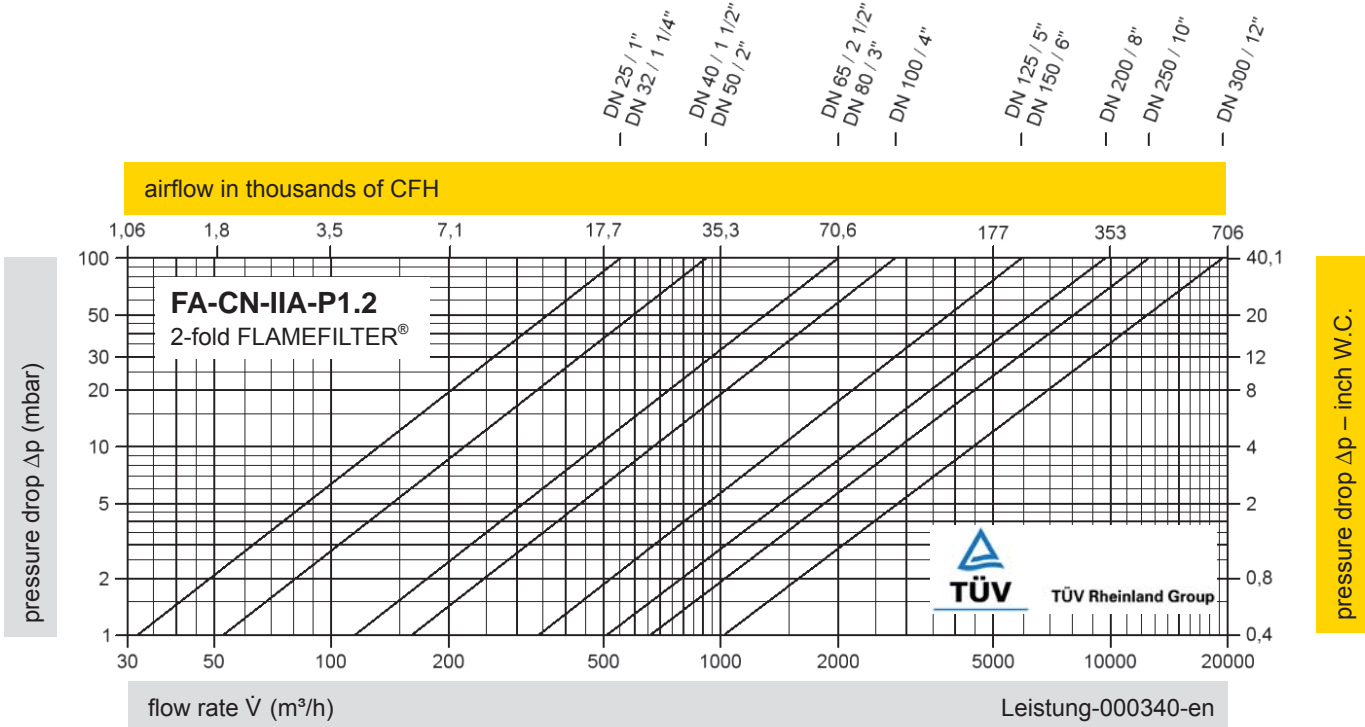

P* see table 3

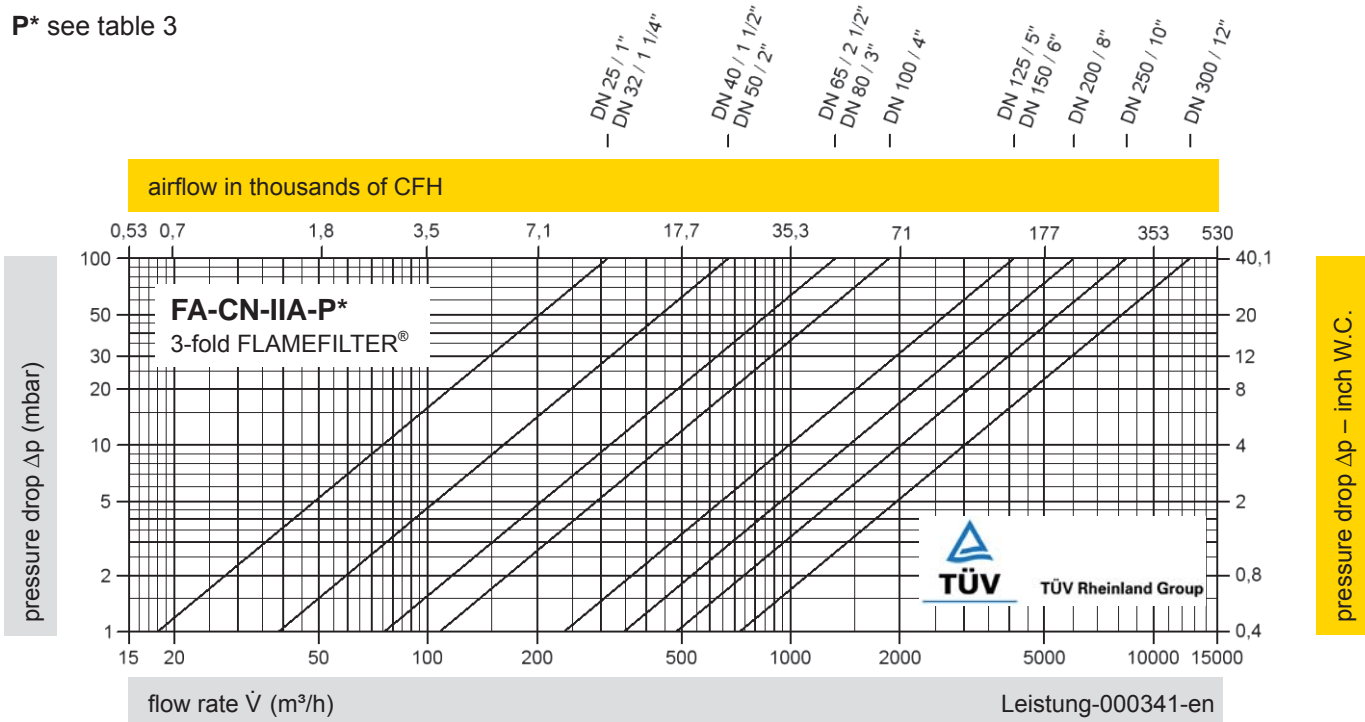

The flow capacity charts have been determined with a calibrated and TÜV certified flow capacity test rig. Volume flow \dot{V} in (m³/h) and CFH refer to the standard reference conditions of air ISO 6358 (20°C, 1bar). Conversion to other densities and temperatures refer to Vol. 1: "Technical Fundamentals".

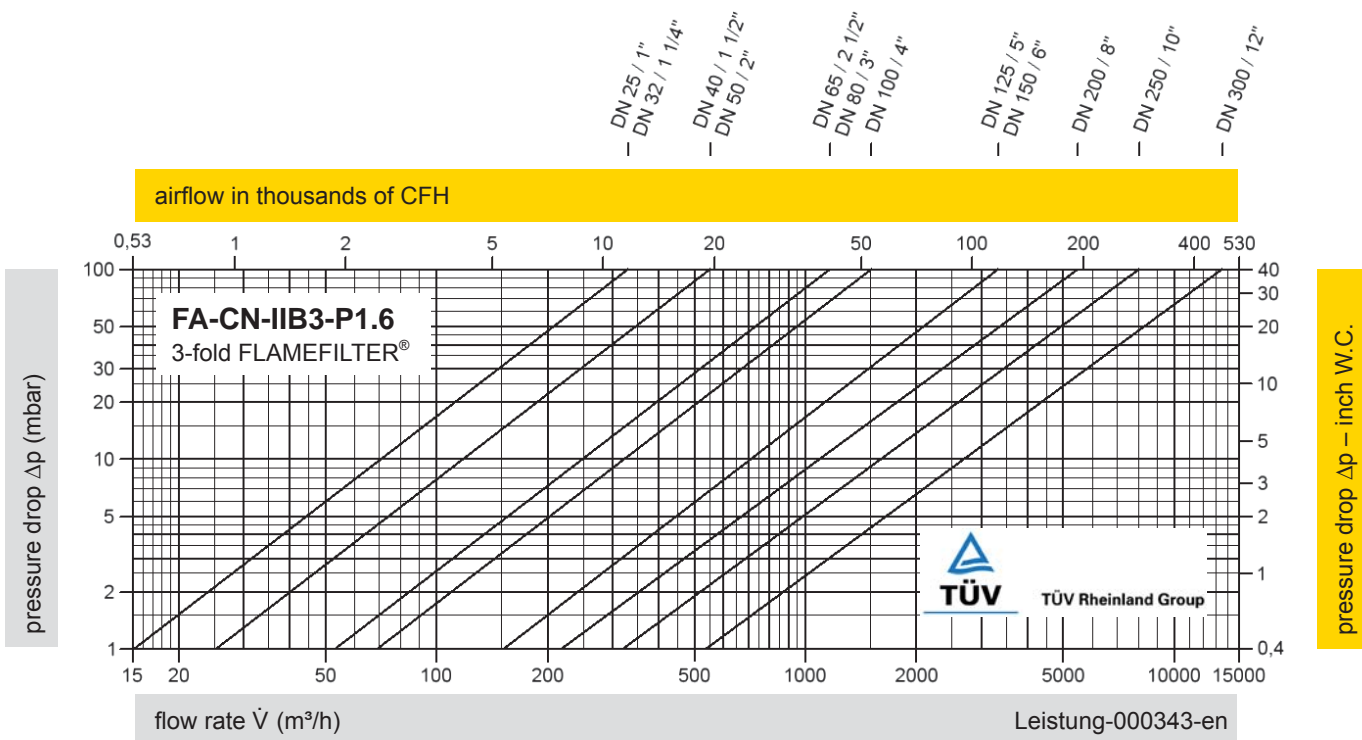
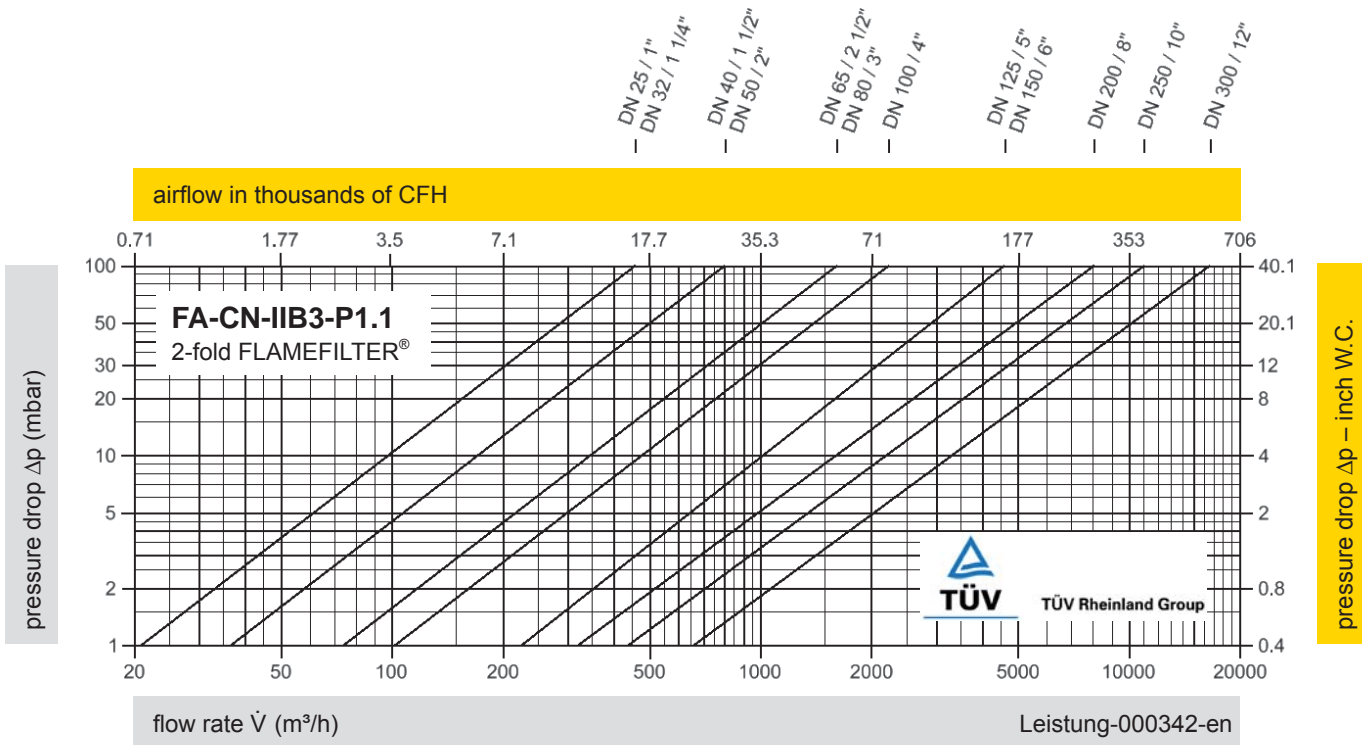

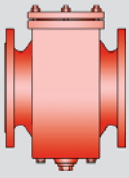

In-Line Deflagration Flame Arrester

for hydrogen/air-mixtures, concentric design,
bidirectional

PROTEGO® FA-CN-IIC

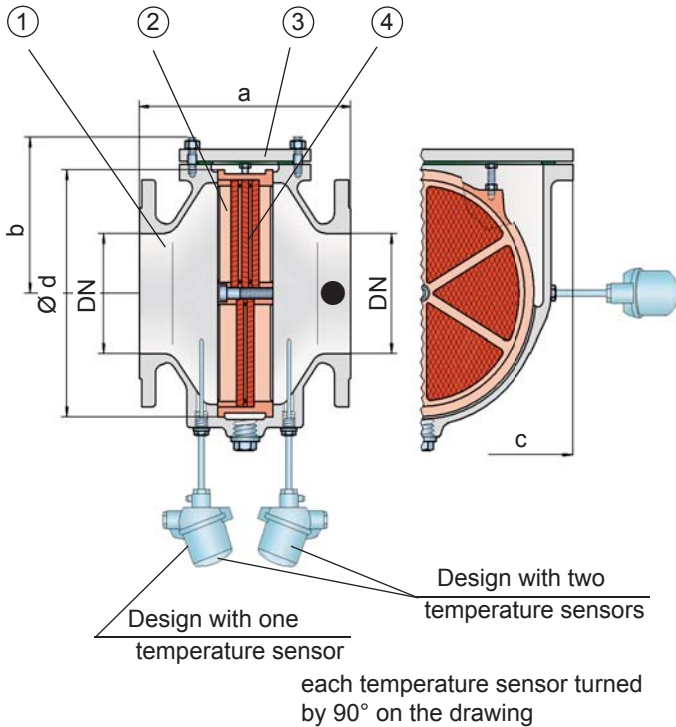

- Connection to the protected side (only for type FA-CN-T-....)

Function and Description

The PROTEGO® FA-CN in-line deflagration flame arrester is a compact design utilizing an easy access cover for easy maintainability. The special PROTEGO® FA-CN-IIC version was developed for hydrogen applications (group IIC vapours – NEC group B). The device is designed to have comparatively large gaps, in relation to other flame arresters for the same explosion group. This allows to apply it to processes having small fluid droplets or particles. The PROTEGO® flame arrester unit can be removed and cleaned within moments without having to disassemble the pipe. When installing the deflagration flame arrester, make sure that the distance between potential ignition sources and the location of the installed device, does not exceed the L/D ratio (pipe length/pipe diameter), for which the device was approved (see table 4).

The deflagration flame arrester is symmetrical and offers bidirectional flame transmission protection. The device consists of a housing (1) with an easy access cover (3) and the PROTEGO® flame arrester unit (2) in the center. The PROTEGO® flame arrester unit is modular and consists of several FLAMEFILTER® discs (3) and spacers firmly held in a FLAMEFILTER® cage. The number of FLAMEFILTER® discs and their gap size depend on the devices intended use.

Providing the operating conditions such as the temperature, pressure, explosion group and the composition of the fluid, enables PROTEGO® to select the best deflagration flame arrester for your application. The versions of PROTEGO® FA-CN-IIC

flame arrester protects against deflagrations of fuel/air mixtures of explosion group IIC (NEC B). FA-CN devices for substances of explosion groups IIA1, IIA and IIB3 (NEC D and C (MESG \geq 0.65 mm)) are shown on separate pages.

The standard design can be used up to an operating temperature of +60°C / 140°F and an absolute operating pressure up to 1.1 bar / 15.9 psi.

Type-approved in accordance with the current ATEX Directive and EN ISO 16852 as well as other international standards.

Special Features and Advantages

- state of the art protection for any hydrogen/air mixture
- can be applied to process flows with small liquid or particle load
- compact design with easy access cover
- easy maintenance without disassembling of the pipeline
- modular flame arrester unit enables individual FLAMEFILTER® to be replaced and cleaned
- bidirectional flame transmission proof design
- protects against deflagrations for all explosion groups
- lowest pressure drop results in low operating and lifecycle costs
- modular design reduces spare parts cost

Design and Specifications

There are three different designs:

Basic in-line deflagration flame arrester **FA-CN -**

In-line deflagration flame arrester with integrated temperature sensor* as additional protection against short time burning from one side **FA-CN -**

In-line deflagration flame arrester with two integrated temperature sensors* for additional protection against short-time burning from both sides **FA-CN -**

Additional special devices available upon request

*Resistance thermometer for device group II, category (1) 2 (GII cat. (1) 2)



Stabilized FLAMEFILTER®
Discs (Flyer pdf)



L/D ratio (Flyer pdf)

Table 1: Dimensions

Dimensions in mm / inches

To select the nominal size (DN), use the flow capacity charts on the following pages

DN	40 / 1½"	50 / 2"	65 / 2½"	80 / 3"	100 / 4"	125 / 5"	150 / 6"	200 / 8"	250 / 10"	300 / 12"
a	210 / 8.27	215 / 8.46	235 / 9.25	240 / 9.45	265 / 10.43	305 / 12.01	310 / 12.20	300 / 11.81	320 / 12.60	350 / 13.78
b	105 / 4.13	105 / 4.13	132 / 5.2	132 / 5.2	150 / 5.91	197 / 7.75	197 / 7.75	220 / 8.66	260 / 10.24	295 / 11.61
c	200 / 7.87	200 / 7.87	260 / 10.24	260 / 10.24	308 / 12.13	415 / 16.34	415 / 16.34	446 / 17.56	520 / 20.47	600 / 23.62
d	130 / 5.12	130 / 5.12	185 / 7.28	185 / 7.28	220 / 8.66	310 / 12.20	310 / 12.20	355 / 13.98	420 / 16.54	490 / 19.29

Table 2: Selection of the explosion group

MESG	Expl. Gr. (IEC/CEN)	Gas Group (NEC)	Special approvals upon request
< 0.50 mm	IIC	B	

Table 3: Selection of max. operation pressure

DN	40 / 1½"	50 / 2"	65 / 2½"	80 / 3"	100 / 4"	125 / 5"	150 / 6"	200 / 8"	250 / 10"	300 / 12"
P _{max}	1.1 / 15.9	1.1 / 15.9	1.1 / 15.9	1.1 / 15.9	1.1 / 15.9	1.1 / 15.9	1.1 / 15.9	1.1 / 15.9	1.1 / 15.9	1.1 / 15.9

P_{max} = maximum allowable operating pressure in bar / psi absolute, higher operating pressure upon request

Table 4: Max. allowable L/D-ratio

DN	40 / 1½"	50 / 2"	65 / 2½"	80 / 3"	100 / 4"	125 / 5"	150 / 6"	200 / 8"	250 / 10"	300 / 12"
(L/D) max	30	30	10	10	10	20	20	10	10	5
Designation	-	-	X12	X12	X12	X10	X10	X12	X12	X13

Table 5: Material selection

Design	A	B	Special materials upon request
Housing	Steel	Stainless Steel	
Cover	Steel	Stainless Steel	
Gasket	PTFE	PTFE	
Flame arrester unit	Stainless Steel	Stainless Steel	

Table 6: Flange connection type

EN 1092-1; Form B1	other types upon request
ASME B16.5; 150 lbs RFSF	



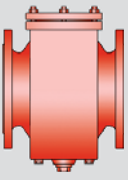

In-Line Deflagration Flame Arrester

Flow Capacity Chart

PROTEGO® FA-CN-IIC

X see table 4

DN 40 / 1 1/2"
 DN 50 / 2"
 DN 65 / 2 1/2"
 DN 80 / 3"
 DN 100 / 4"
 DN 125 / 5"
 DN 150 / 6"
 DN 200 / 8"
 DN 250 / 10"
 DN 300 / 12"

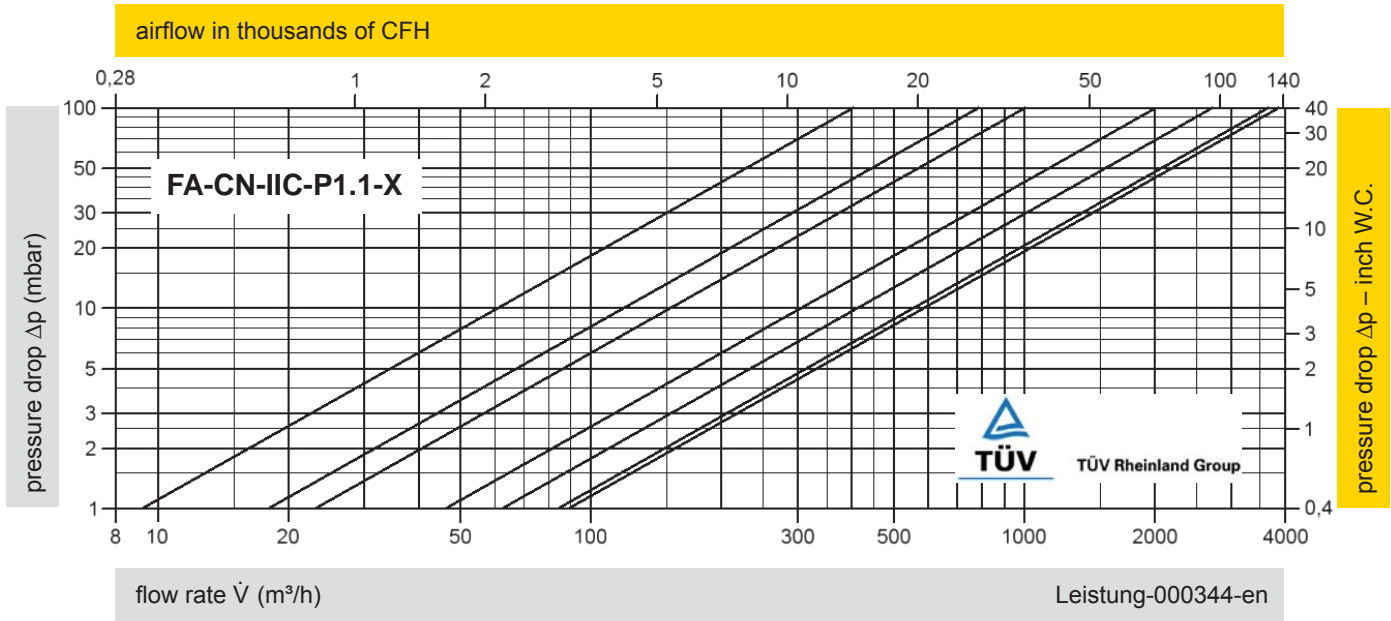

The flow capacity chart has been determined with a calibrated and TÜV certified flow capacity test rig. Volume flow \dot{V} in (m³/h) and CFH refer to the standard reference conditions of air ISO 6358 (20°C, 1bar). Conversion to other densities and temperatures refer to Vol. 1: "Technical Fundamentals".

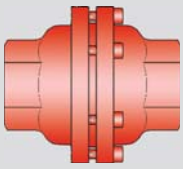

In-Line Deflagration Flame Arrester

concentric design,
bidirectional

PROTEGO® FA-G

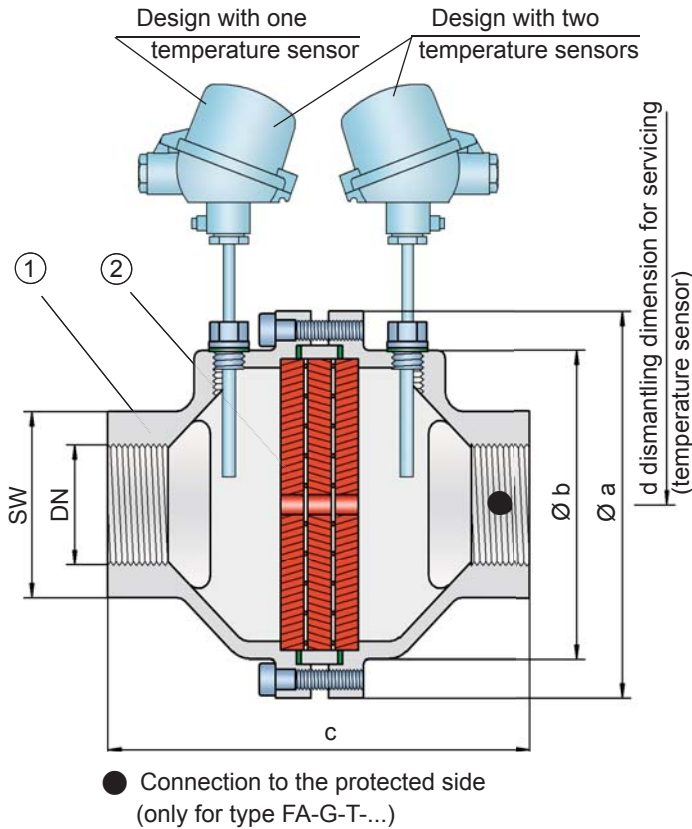

terminated by the operating data and parameters of the mixture flowing in the line (explosion group, pressure, temperature). The PROTEGO® FA-G series in-line deflagration flame arresters is available for explosion groups IIA, IIB3 and IIC (NEC groups D, C (MESG \geq 0.65 mm) and B).

The standard design can be used up to an operating temperature of +60°C / 140°F and an absolute operating pressure acc. to table 3. **Devices with special approval can be obtained for higher pressures and higher temperatures upon request.**

Type-approved in accordance with the current ATEX Directive and EN ISO 16852 as well as other international standards.

Special Features and Advantages

- different application possibilities
- modular design
- the individual FLAMEFILTER® can be quickly removed and installed
- threaded connection for direct mounting into pipeline
- bidirectional flame transmission proof design
- protects against deflagrations for all explosion groups
- use of temperature sensors for G 1½ and G 2 is possible
- cost efficient spare parts

Function and Description

The compact design of the PROTEGO® FA-G in-line deflagration flame arrester makes it the state of the art technology for installation in pipes with diameters of up to 2". The devices are installed with minimal distance to the burner to prevent flashback in to the fuel feed lines. When installing the deflagration flame arrester, make sure that the distance between potential ignition sources and the location of the installed device, does not exceed the L/D ratio (pipe length/pipe diameter), for which the device was approved. As per EN ISO 16852 the L/D ratio is limited to $(L/D)_{\max} \leq 50$ for deflagration flame arresters of explosion groups IIA and IIB3 (NEC groups D and C (MESG \geq 0.65 mm)) and to $(L/D)_{\max} \leq 30$ for explosion group IIC (NEC group B).

The in-line deflagration flame arrester is symmetrical and offers bidirectional flame transmission protection. The device consists of two housing parts (1) and a PROTEGO® flame arrester unit or a FLAMEFILTER® (2) and spacers in the center. The number of FLAMEFILTER® discs and their gap size are de-

Design and Specifications

There are three different designs:

Basic in-line deflagration flame arrester **FA-G-** (size ½" to 2")

In-line deflagration flame arrester with integrated temperature sensor* for additional protection against short-time burning from one side (size 1½" to 2") **FA-G-**

In-line deflagration flame arrester with two integrated temperature sensors* for additional protection against short-time burning from both sides (size 1½" to 2") **FA-G-**

*Resistance thermometer for device group II, category (1) 2 (GII cat. (1) 2)

Flange connection available upon request



Table 1: Dimensions

Dimensions in mm / inches, SW = width across flats

To select the nominal size (DN), use the flow capacity charts on the following pages

DN	G ½	G ¾	G 1	G 1 ¼	G 1 ½	G 2
a	80 / 3.15	80 / 3.15	100 / 3.94	100 / 3.94	155 / 6.10	155 / 6.10
b	55 / 2.17	55 / 2.17	76 / 2.99	76 / 2.99	124 / 4.88	124 / 4.88
c (IIA up to IIB3)	100 / 3.94	100 / 3.94	110 / 4.33	110 / 4.33	170 / 6.69	170 / 6.69
c (IIB and IIC)	112 / 4.41	112 / 4.41	122 / 4.80	122 / 4.80	170 / 6.69	170 / 6.69
d	—	—	—	—	400 / 15.75	400 / 15.75
SW	32 / 1.26	32 / 1.26	50 / 1.97	50 / 1.97	75 / 2.95	75 / 2.95

Table 2: Selection of the explosion group

MESG	Expl. Gr. (IEC/CEN)	Gas Group (NEC)	Special approvals upon request
> 0.90 mm	IIA	D	
≥ 0.65 mm	IIB3	C	
< 0.50 mm	IIC	B	

Table 3: Selection of max. operating pressure

DN		G ½	G ¾	G 1	G 1 ¼	G 1 ½	G 2	P _{max} = maximum allowable operating pressure in bar / psi absolute, higher operating pressure upon request	
Expl. Gr.	IIA	P _{max}	1.4/20.3	1.4/20.3	1.4/20.3	1.4/20.3	1.5/21.7		1.5/21.7
	IIB3	P _{max}	1.2/17.4	1.2/17.4	1.2/17.4	1.2/17.4	1.2/17.4		1.2/17.4
	IIC	P _{max}	1.1/15.9	1.1/15.9	1.1/15.9	1.1/15.9	1.1/15.9		1.1/15.9

Table 4: Specification of max. operating temperature

≤ 60°C / 140°F	T _{maximum allowable operating temperature in °C}	higher operating temperatures upon request
-	Designation	

Table 5: Material selection

Design	B	C	* the FLAMEFILTER® is also available in the materials Tantalum, Inconel, Copper, etc. when the listed housing materials are used.
Housing	Stainless Steel	Hastelloy	
Gasket	PTFE	PTFE	
FLAMEFILTER®*	Stainless Steel	Hastelloy	

Special materials upon request.

Table 6: Type of connection

Pipe thread DIN ISO 228-1	DIN	other types of thread upon request
---------------------------	-----	------------------------------------



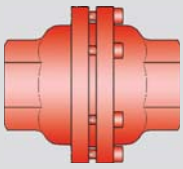

In-Line Deflagration Flame Arrester

Flow Capacity Charts

PROTEGO® FA-G-IIIA, IIB3 and IIC

P* see table 3

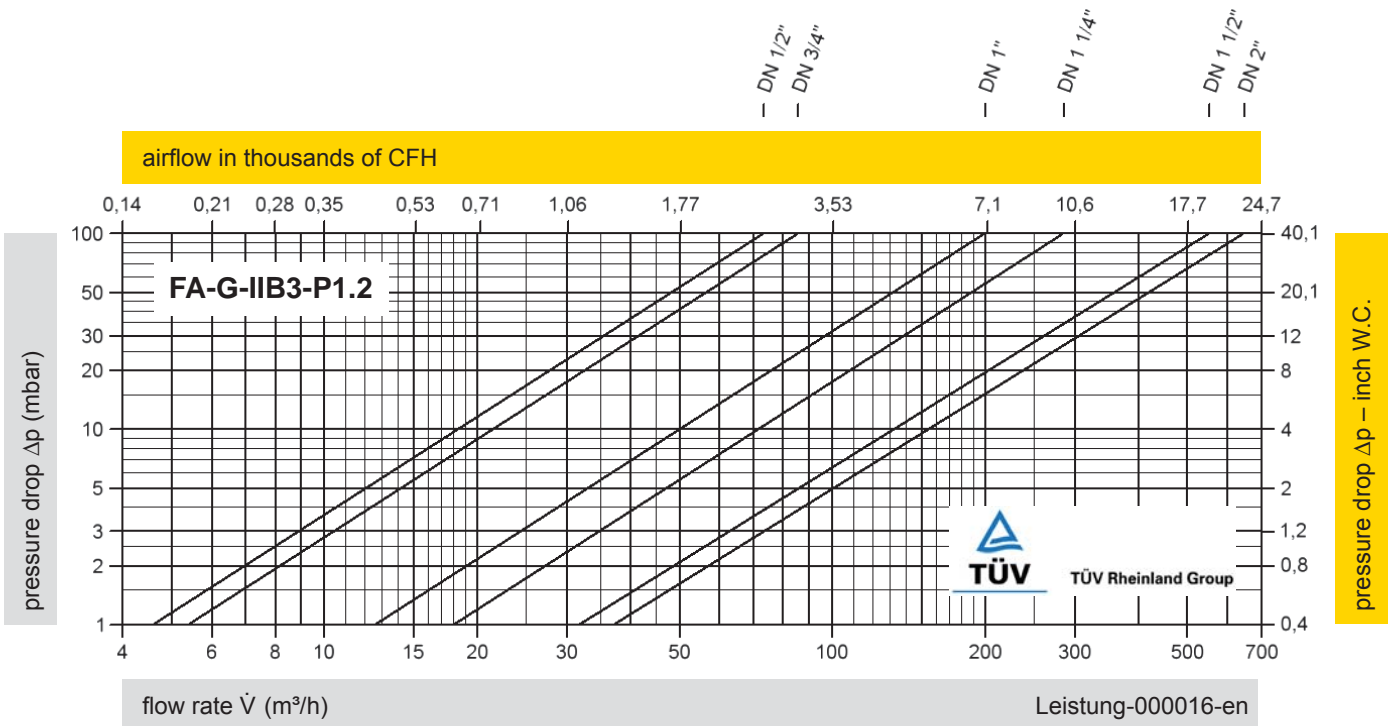
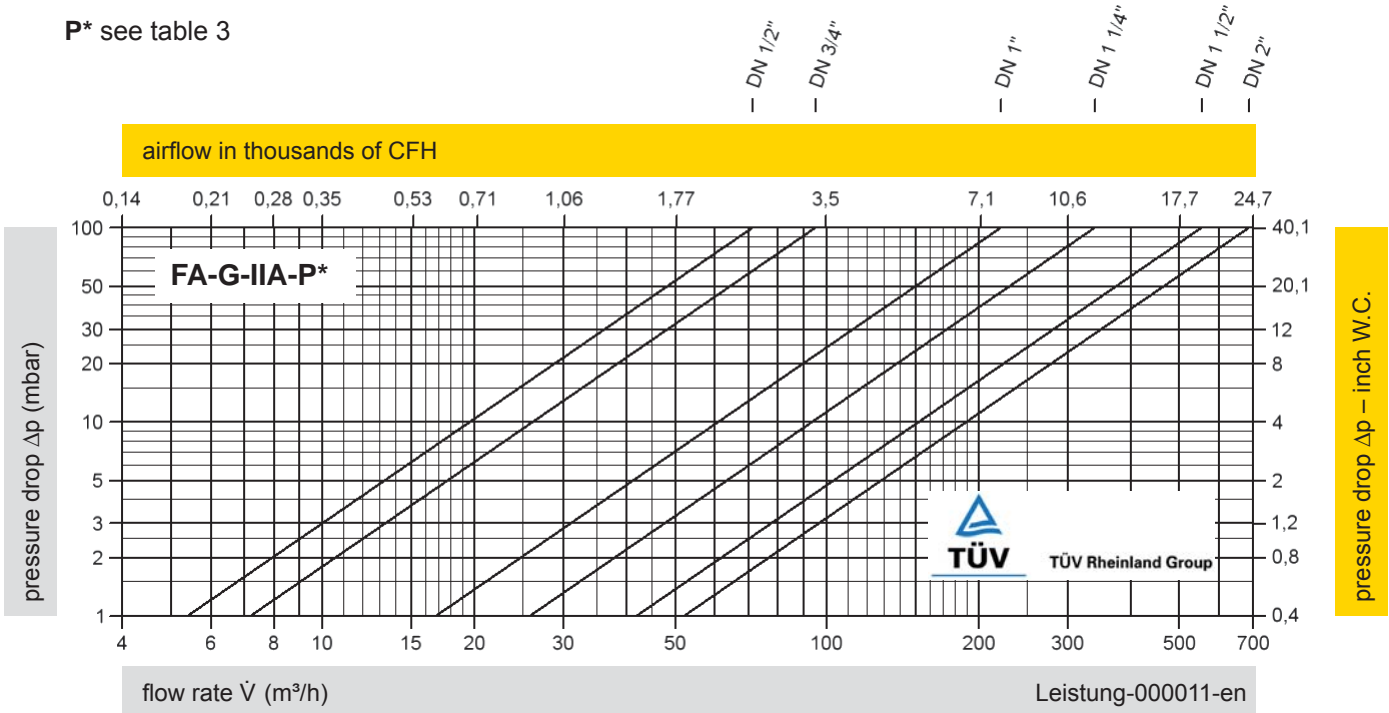

The flow capacity charts have been determined with a calibrated and TÜV certified flow capacity test rig.
 Volume flow \dot{V} in (m³/h) and CFH refer to the standard reference conditions of air ISO 6358 (20°C, 1bar).
 Conversion to other densities and temperatures refer to Vol. 1: "Technical Fundamentals".

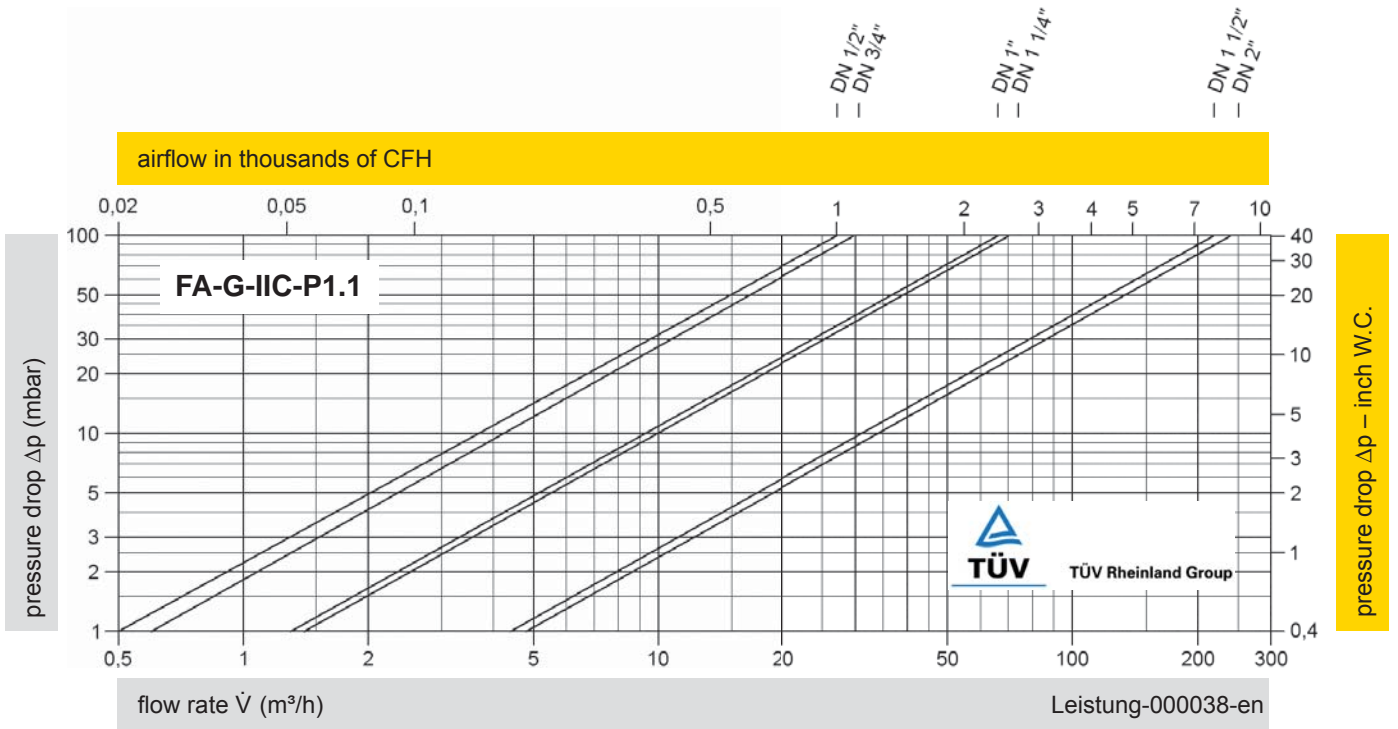

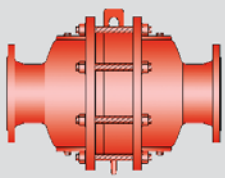

In-Line Deflagration Flame Arrester

concentric design,
bidirectional

PROTEGO® FA-I

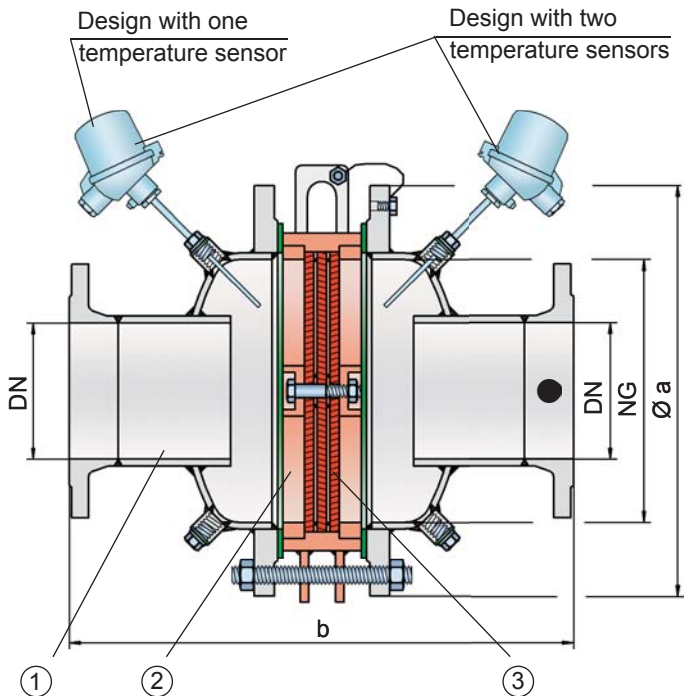

● Connection to the protected side
(only for type FA-I-T-....)

Function and Description

In the development of the PROTEGO® FA-I in-line deflagration flame arrester, special effort was made to optimize the fluid dynamic flow characteristics. For a given flange connection size of the flame arrester, the FLAMEFILTER® size can be chosen for the most adequate flow capacity. When installing the deflagration flame arrester, make sure that the distance between potential ignition sources and the location of the installed device, does not exceed the L/D ratio (pipe length/pipe diameter), for which the device was tested (see table 4).

The deflagration flame arrester is symmetrical and offers bidirectional flame transmission protection. The device essentially consists of two housing parts (1) and the PROTEGO® flame arrester unit (2) in the center. The PROTEGO® flame arrester unit is modular and consists of several FLAMEFILTER® discs (3) and spacers firmly held in a FLAMEFILTER® cage. The number of FLAMEFILTER® discs and their gap size depends on the arrester's conditions of use.

Providing the operating conditions such as the temperature, pressure, explosion group and the composition of the fluid, enables PROTEGO® to select the best deflagration flame arrester for your application. The PROTEGO® FA-I series of deflagration flame arresters is available for substances of explosion groups IIA and IIB3 (NEC groups D and C (MESG ≥ 0.65 mm)).

The standard design can be used up to an operating temperature of +60°C/ 140°F and an absolute operating pressure up to 1.1 bar / 15.9 psi. **Devices with special approvals can be obtained for higher pressures (see table 3) and higher temperatures upon request.**

Type-approved in accordance with the current ATEX Directive and EN ISO 16852 as well as other international standards.

Special Features and Advantages

- optimized flow capacity
- different series allow increase of FLAMEFILTER® size for given flange connection resulting in lower pressure drop across the device
- option for integrated cleaning nozzles can be provided
- modular flame arrester unit enables each individual FLAMEFILTER® to be replaced and cleaned
- bidirectional flame transmission proof design
- protects with deflagrations for explosion groups IIA and IIB3 (NEC groups D and C)
- design available for elevated operating temperatures and pressures
- available sizes from DN 50 / 2" to DN 1000 / 40"
- lowest pressure drop results in low operating and lifecycle costs
- modular design reduces spare parts cost
- use of stabilized FLAMEFILTER® discs is possible
- use of PROTEGO® Flame Arrester Unit in unique maintenance friendly design reduces service cost

NEW

Design and Specifications

There are three different designs:

Basic deflagration flame arrester design FA-I-

In-line deflagration flame arrester with integrated temperature sensor* for additional protection against short-time burning from one side FA-I-

In-line deflagration flame arrester with two integrated temperature sensors* for additional protection against short-time burning from both sides FA-I-

Additional special devices available upon request

*Resistance thermometer for device group II, category (1) 2 (GII cat. (1) 2)



Stabilized FLAMEFILTER®
Discs (Flyer pdf)



New PROTEGO® Flame Arrester Unit unique
maintenance friendly design (Flyer pdf)

Table 1: Dimensions

Dimensions in mm / inches

To select nominal width/nominal size (NG/DN) - combination, please use the flow capacity charts on the following pages						Additional nominal width/nominal size (NG/DN) - combinations for improved flow capacity upon request							
standard													
NG	150 6"	150 6"	200 8"	300 12"	400 16"	500 20"	600 24"	800 32"	1000 40"	1200 48"	1400 56"	1600 64"	
DN	≤ 50 2"	80 3"	≤ 100 4"	≤ 150 6"	≤ 200 8"	≤ 250 10"	≤ 300 12"	≤ 400 16"	≤ 500 20"	≤ 600 24"	≤ 800 32"	≤ 800 32"	
a	285 / 11.22	285 / 11.22	340 / 13.39	445 / 17.52	565 / 22.24	670 / 26.38	780 / 30.71	975 / 38.39	1175 / 46.26	1405 / 55.31	1630 / 64.17	1830 / 72.05	
Expl. Gr.	IIA b*	364 / 14.33	364 / 14.33	452 / 17.79	584 / 22.99	638 / 25.12	688 / 27.09	800 / 31.50	900 / 35.43	1000 / 39.37	1100 / 43.31	1350 / 53.15	1450 / 57.09
	IIB3 b*	364 / 14.33	364 / 14.33	464 / 18.27	596 / 23.46	650 / 25.59	700 / 27.56	800 / 31.50	900 / 35.43	1000 / 39.37	1100 / 43.31	1350 / 53.15	1450 / 57.09
c	500 / 19.69	500 / 19.69	520 / 20.47	570 / 22.44	620 / 24.41	670 / 26.38	700 / 31.50	900 / 35.43	1000 / 39.37	1100 / 43.31	1350 / 53.15	1450 / 57.09	

*Dimension b only for P1.2 (IIA) and P1.1 (IIB3).

Table 2: Selection of the explosion group

MESG	Expl. Gr. (IEC/CEN)	Gas Group (NEC)	Special approvals upon request
> 0.90 mm	IIA	D	
≥ 0.65 mm	IIB3	C	

Table 3: Selection of max. operating pressure

NG	150 6"	150 6"	200 8"	300 12"	400 16"	500 20"	600 24"	800 32"	1000 40"	1200 48"	1400 56"	1600 64"	
DN	≤ 50 2"	80 3"	≤ 100 4"	≤ 150 6"	≤ 200 8"	≤ 250 10"	≤ 300 12"	≤ 400 16"	≤ 500 20"	≤ 600 24"	≤ 800 32"	≤ 800 32"	
Expl. Gr.	IIA	P _{max} 1.8 / 26.1	1.8 / 26.1	1.5 / 21.7	1.5 / 21.7	1.5 / 21.7	1.5 / 21.7	1.5 / 21.7	1.4 / 20.3	1.3 / 18.8	1.3 / 18.8	1.2 / 17.4	1.1 / 15.9
	IIB3	P _{max} 1.2 / 17.4	1.2 / 17.4	1.2 / 17.4	1.2 / 17.4	1.2 / 17.4	1.2 / 17.4	1.2 / 17.4	1.2 / 17.4	1.2 / 17.4	1.1 / 15.9	1.1 / 15.9	1.1 / 15.9

P_{max} = maximum allowable operating pressure in bar / psi absolut, higher operating pressure upon request



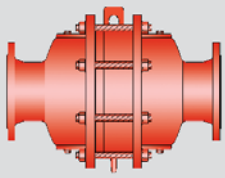

In-Line Deflagration Flame Arrester

concentric design,
bidirectional

PROTEGO® FA-I

Table 4: Table 4: Max. allowable L/D-ratio

standard												
NG	150 6"	150 6"	200 8"	300 12"	400 16"	500 20"	600 24"	800 32"	1000 40"	1200 48"	1400 56"	1600 64"
DN	≤ 50 2"	80 3"	≤ 100 4"	≤ 150 6"	≤ 200 8"	≤ 250 10"	≤ 300 12"	≤ 400 16"	≤ 500 20"	≤ 600 24"	≤ 800 32"	≤ 800 32"
(L/D) _{max}	50	50	50	50	50	50	50	50	50	50	50	50
IIA	P _{max}	1.2 / 17.4	1.2 / 17.4	1.2 / 17.4	1.2 / 17.4	1.2 / 17.4	1.2 / 17.4	1.2 / 17.4	1.3 / 18.8	1.3 / 18.8	1.2 / 17.4	1.1 / 15.9
	Designation	-	-	-	-	-	-	-	-	-	-	-
IIB3	(L/D) _{max}	50	50	40	40	35	35	35	30	30	30	25
	P _{max} (bar /psi)	1.1 / 15.9	1.1 / 15.9	1.1 / 15.9	1.1 / 15.9	1.1 / 15.9	1.1 / 15.9	1.1 / 15.9	1.1 / 15.9	1.1 / 15.9	1.1 / 15.9	1.1 / 15.9
	Designation	-	-	X6	X6	X7	X7	X7	X8	X8	X8	X9

Table 5: Specification of max. operating temperature

≤ 60°C / 140°F	T _{maximum allowable operating temperature in °C}	higher operating temperatures upon request
-	Designation	

Table 6: Material selection for housing

Design	A	B	C
Housing	Steel	Stainless Steel	Hastelloy
Gasket	PTFE	PTFE	PTFE
Flame arrester unit	A, B	C	D

The housing can also be delivered in carbon steel with an ECTFE coating.

Special materials upon request.

Table 7: Material combinations of the flame arrester unit

Design	A	C	D
FLAMEFILTER® cage	Steel	Stainless Steel	Hastelloy
FLAMEFILTER® *	Stainless Steel	Stainless Steel	Hastelloy
Spacers	Stainless Steel	Stainless Steel	Hastelloy

* the FLAMEFILTER® is also available in the materials Tantalum, Inconel, Copper, etc. when the listed housing and cage materials are used

Special materials upon request.

Table 8: Flange connection type

EN 1092-1; Form B1	other types upon request
ASME B16.5; 150 lbs RFSF	

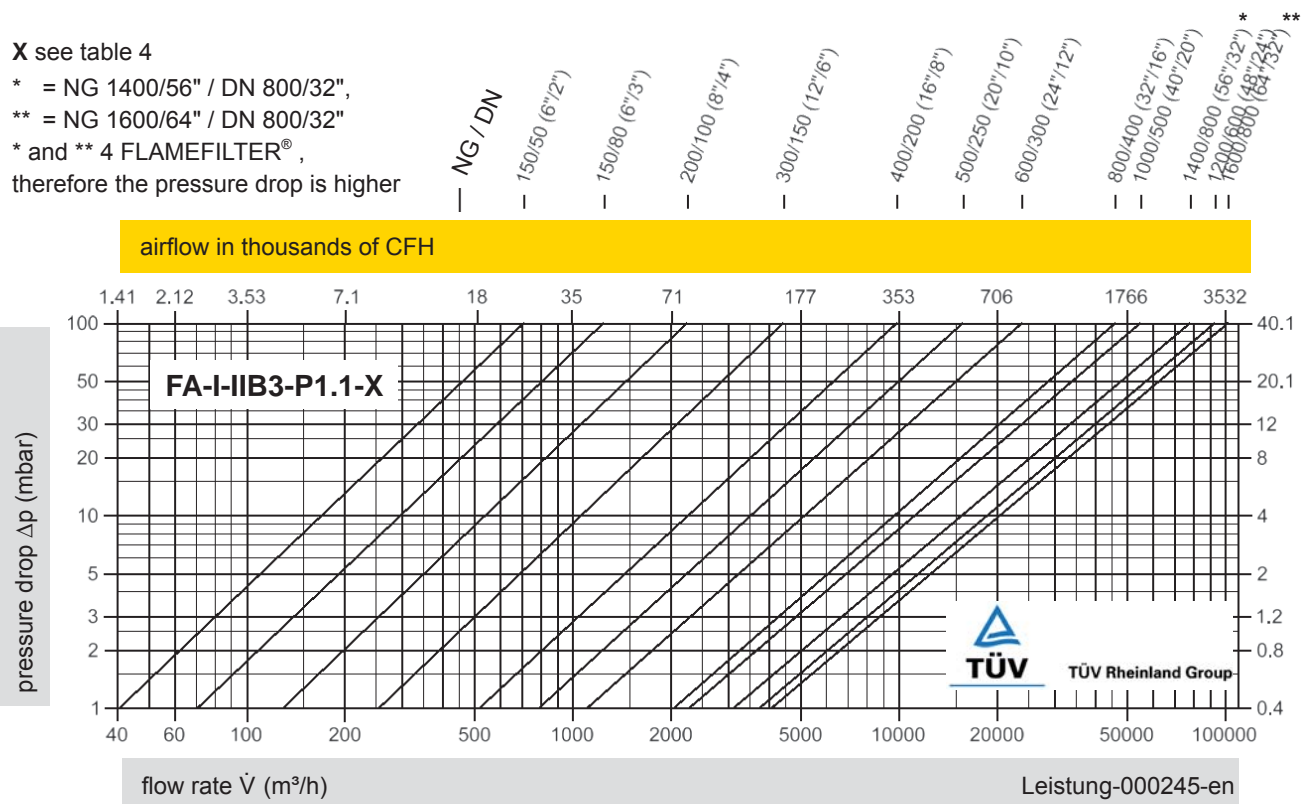
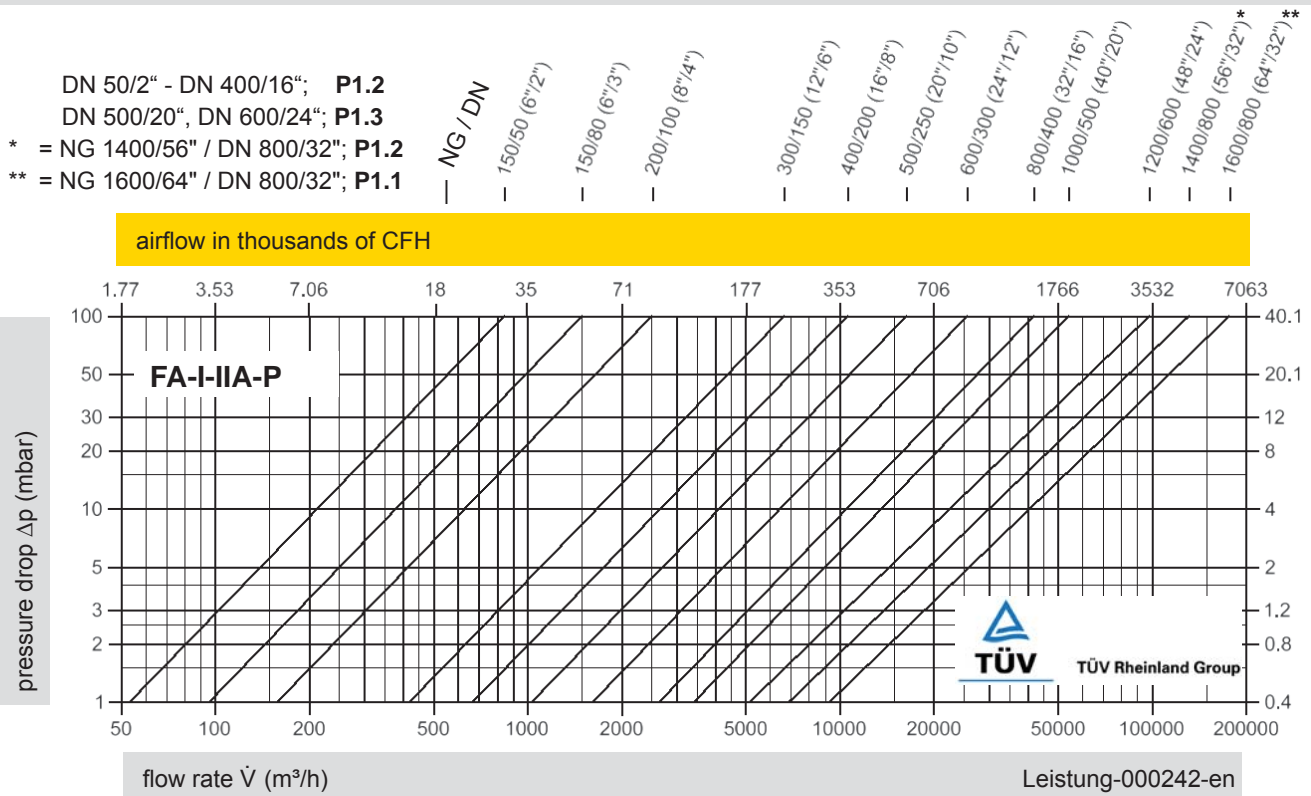

The flow capacity charts have been determined with a calibrated and TÜV certified flow capacity test rig. Volume flow \dot{V} in (m³/h) and CFH refer to the standard reference conditions of air ISO 6358 (20°C, 1bar). Conversion to other densities and temperatures refer to Vol. 1: "Technical Fundamentals".



www.protego.com



for safety and environment

PROTEGO® Detonation Flame Arresters

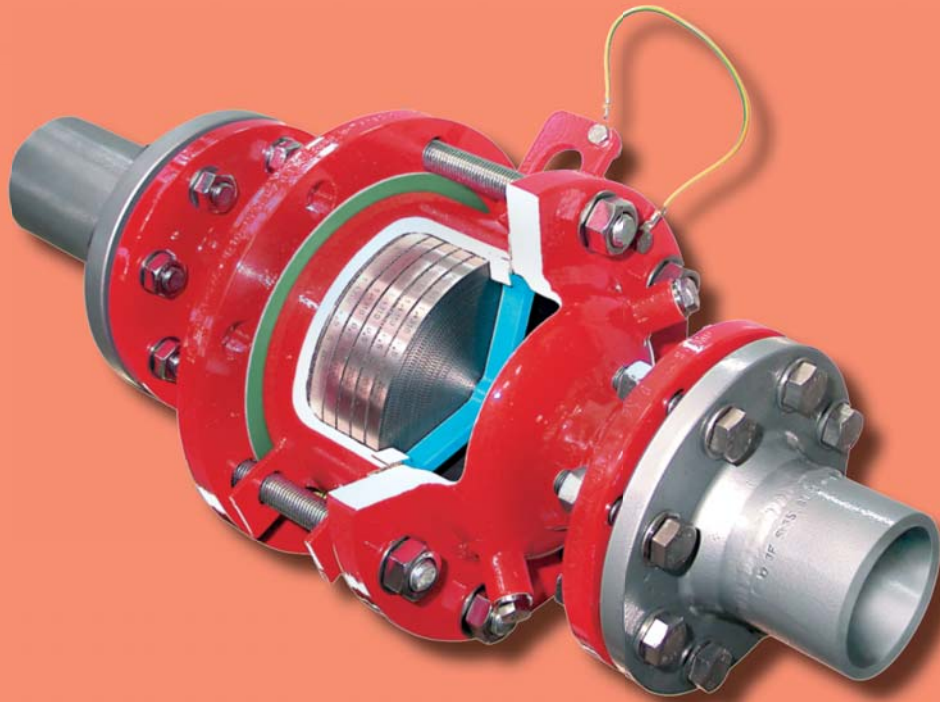

Volume 4

Volume 4



for safety and environment



Function and description

The function of flame arresters in the various combustion processes and applications is discussed in „Technical Fundamentals“ (→ Vol. 1). In this chapter, PROTEGO®'s product line of **detonation arresters** for **stable** and **unstable detonations** is presented.

PROTEGO® detonation flame arresters are highly developed safety devices that are used in pipe systems in which detonations can occur. They reliably suppress the effect of a detonation, extinguish the flame, and protect non-explosionproof components and vessels.

The main component generally is the original PROTEGO® flame arrester unit (1), which takes the energy from the detonation and extinguish the flame in narrow gaps. The PROTEGO® flame arrester unit consists of several FLAMEFILTER® discs (2) and spacers, firmly held in the FLAMEFILTER® cage (3). The number of FLAMEFILTER® discs and their gap size depend on the devices intended use and on process parameters such as temperature, pressure, vapour group of the handled gases.

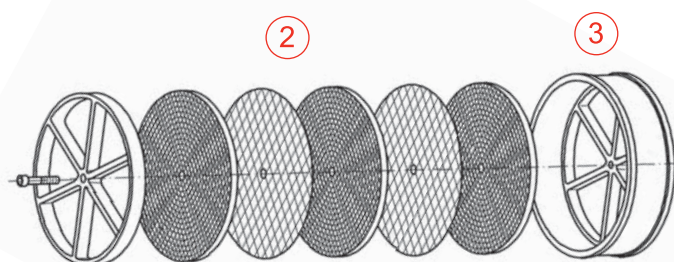

① PROTEGO® flame arrester unit

All dry detonation flame arrester types have a modular design. For larger nominal diameters, energy is withdrawn from the detonation shock wave upon entering the patented shock absorber, the SWGTE (Shock Wave Guide Tube Effect), and other innovative technical solutions, before the detonation reaches the FLAMEFILTER®.

Dry PROTEGO® detonation flame arresters are also tested and safe with respect to deflagrations. Equipped with an additional temperature sensor, they are also protected from short-time stabilized burning on the FLAMEFILTER®.

In close collaboration with scientific institutions, PROTEGO® has developed safety devices that can be used in any area subject to an explosion hazard and protects against stable and unstable detonations, unidirectional or bidirectional. Corresponding statements of conformity (CE, etc.) have been awarded based on type tests according to ATEX, PED, and other international standards.

A wide range of types, designs, nominal diameters and materials are available. In addition, we are able to develop tailor made solutions at our worldwide unique testing facility.

Special features and advantages

The most important distinctive features are the selection criteria: **Stable or unstable** detonations, **dry detonation arresters** for installation in gas- or vapour-conducting pipes, or **liquid detonation arresters**, i.e. flame arresters with a liquid barrier for pipes in which liquids are transported. For the parameters of pressure and temperature, **special operating conditions** beyond standard values may have to be considered.

It is important to categorize the products or the components of the mixture into **explosion groups** according to their MESG to select the suitable flame arrester from the various designs for all the explosion groups.

The designs differ according to their **concentric, eccentric, and 90-degree design**.

The respective system specification must be considered when choosing the required **nominal diameters and types of connection**.

A **heating jacket** may be necessary, but not every device can be provided with a heating jacket.

There are designs for **critical media**, special **product properties** (such as viscosity, density, crystallization, and polymerization), and for **unidirectional or bidirectional protection**.

Preferred applications

Protection of

- Piping systems
- Tanks and vessels in chemical, petrochemical, and pharmaceutical processing plants
- Loading systems
- Gas collection systems
- Exhaust gas combustion systems
- Flare systems
- Landfills and biogas systems
- Waste-water treatment plants

Installation and maintenance

PROTEGO® detonation flame arresters are also tested and protect against deflagrations so that they can be used at any distance from a potential ignition source. However, they are preferably installed as close as possible to the part of the system to be protected. No pipes with a nominal diameter greater than the nominal diameter of the devices shall be connected to detonation arresters.

Given the modular design of the PROTEGO® flame arrester unit, any type of detonation flame arrester is extremely easy to service. For servicing reasons, the location of the flame arrester must be planned to be very accessible; a hoist must be provided if the flame arrester is heavy. Servicing is easy for trained personnel.

PROTEGO® detonation flame arresters are used in areas subject to explosion hazards. Select devices that match the intended use. The manufacturer's certificate of conformity provides the boundary conditions for which the device is suitable. The user has to document proper use in accordance with applicable safety guidelines or standards.

Selection

The possible types are pre-selected from the product line based on the most important process data:

- **Stable detonations or unstable detonations**
- Lines that conduct **dry gas/vapours or liquids**
- Standard or **non-standard operating conditions** (pressure and temperature)
- **Explosion group** of the transported mixture

Finally, the following criteria are reviewed and selected:

- Approvals according to ATEX, USCG, CSA, GOST-R, GL, IMO, etc.
- Concentric, excentric, or 90-degree design
- Nominal diameter and type of connection
- Heating jacket or custom-supplied electrical heat tracing
- Critical media
- Unidirectional or bidirectional

If no suitable device can be found, please contact us. Special designs and approvals are available.

Based on this initial selection, the additional details such as materials, coatings, etc. can be requested or defined in the type sheet.

Sizing

The nominal diameter of the device is determined or checked in the p/V flow chart. A safety margin must be provided when the processed fluid is highly contaminated.

- Given:** Volume flow m³/h or CFH
- Given:** Max. all. pressure drop Δp mbar or inch W.C.
- Desired:** Nominal diameter of the detonation flame arrester DN

Procedure: Intersection of the lines with the volume flow and maximum allowable pressure drop lies above or on the desired nominal diameter curve

or

- Given:** Volume flow m³/h or CFH
- Given:** Nominal diameter of pipe DN
- Desired:** Pressure drop Δp mbar or inch W.C.

Procedure: Intersection of the lines with the volume flow and nominal diameter curve, horizontal straight line leads to the desired pressure drop

Instructions on how to calculate the volumetric flow or influence of density are found in Vol. 1 „Technical Fundamentals“.



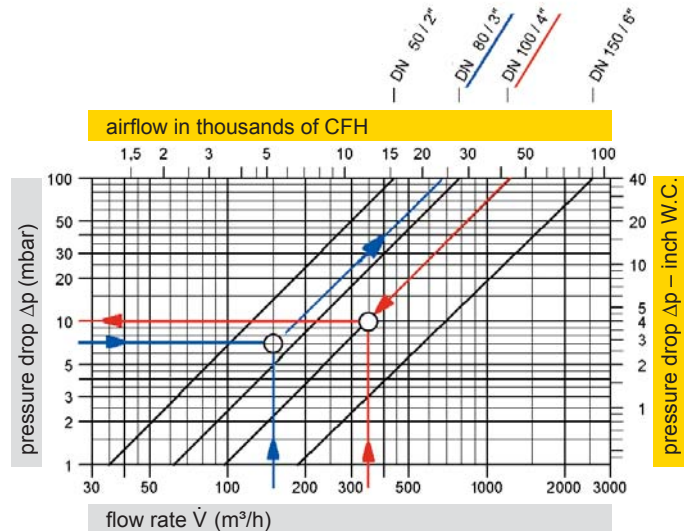







After all steps are complete, the device can be completely specified and requested or ordered.





PROTEGO® Detonation Flame Arrester

Image	Type	Size	Design cc = concentric ec = eccentric	Explosion Group		Approvals			○ = dry type x = liquid type	○ = for non-standard operating parameter	○ = for critical medium (polymerisation, corrosion, crystallisation)	○ = Heating jacket, Heating coil	○ = unidirectional, x = bidirectional	Page
				ATEX	NEC									
for stable detonation														
	DA-G	G ½ - G 2	straight through, cc	IIA, IIB3, IIC	D, C, B	ATEX			○	○			x	118 - 121
	DR/SV	G ½ - G ¾	straight through, cc	IIA	D	ATEX			○				○	
	DA-E	25-300 1" - 12"	straight through, ec	IIA, IIB3	D, C	ATEX			○	○			x	122 - 124
	DA-SB	50-600 2" - 24"	straight through, cc	IIA, IIB3, IIC	D, C, B	ATEX			○	○		○	x	126 - 131
	DA-SB-PTFE	50-100 2" - 4"	straight through, cc	IIA	D	ATEX			○		○		x	
	DR/ES	G ¼ -G ¾	90-degree	IIA, IIB3, IIC	D, C, B	ATEX			○	○			○	132 - 134
	DR/ES	25-200 1" - 8"	90-degree	IIA, IIB3	D, C	ATEX			○/x	○		○	○	136 - 140
	DR/ES series 2	50-100 2" - 4"	90-degree	IIA, IIB3	D, C	ATEX			○/x	○		○	○	
	DR/ES-V	40-200 1 ½" - 8"	90-degree	IIA, IIB3	D, C	ATEX			○	○		○	○	142 - 145
	DR/ES-PTFE	40-150 1 ½" - 6"	90-degree	IIA	D	ATEX			○		○		○	
	DR/SBW	50-400 2" - 16"	straight through, cc	IIA, IIB3	D, C	ATEX			○	○		○	x	
	BR/TS	80 3"	90-degree	IIB3, IIB	C, B	ATEX			○				○	-IIB -IIB3

	Type	Size	Design cc = concentric ec = eccentric	Explosion Group		Approvals		O = dry type x = liquid type	O = for non-standard operating parameter	O = for critical medium (polymerisation, corrosion, crystallisation)	O = Heating jacket, Heating coil	O = unidirectional, x = bidirectional	Page
				ATEX	NEC								
for stable detonation / for liquid detonation													
	LDA-W	25-300 1" - 12"	straight through	IIA, IIB3	D, C	ATEX		x		O		O	146 - 147
	LDA-WF(W)	25-250 1" - 10"	straight through	IIA, IIB3	D, C	ATEX		x		O		O	148 - 149
	LDA	25-250 1" - 10"	vertical	IIA, IIB3	D, C	ATEX		x				O	150 - 151
	LDA-F	25-250 1" - 10"	vertical	IIA, IIB3	D, C	ATEX		x				O	152 - 153
	EFV	25-250 1" - 10"	vertical	IIB3	C	ATEX		x				O	154 - 155
	TS/P TS/E TS/W			IIA, IIB3, IIC	D, C, B	ATEX		x		O		O	156 - 157
for unstable detonation													
	DA-UB	50-600 2" - 24"	straight through, cc	IIA, IIB3	D, C	ATEX		O	O		O	x	158 - 161
	DA-CG	50-600 2" - 24"	straight through, cc	IIA, IIB3	D, C	USCG		O	O		O	x	162 - 165
	DR/EU	25-150 1" - 6"	90-degree	IIA, IIB2, IIB3	D, C, C	ATEX		O	O		O	O	166 - 168
	DA-UCG	50-400 2" - 16"	straight through, cc	IIA	D	ATEX USCG		O	O		O	x	169 - 171

Larger sizes upon request

NEW



for safety and environment

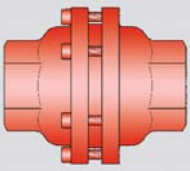

In-Line Detonation Flame Arrester

for stable detonations and deflagrations in a straight through design,
bidirectional

PROTEGO® DA-G

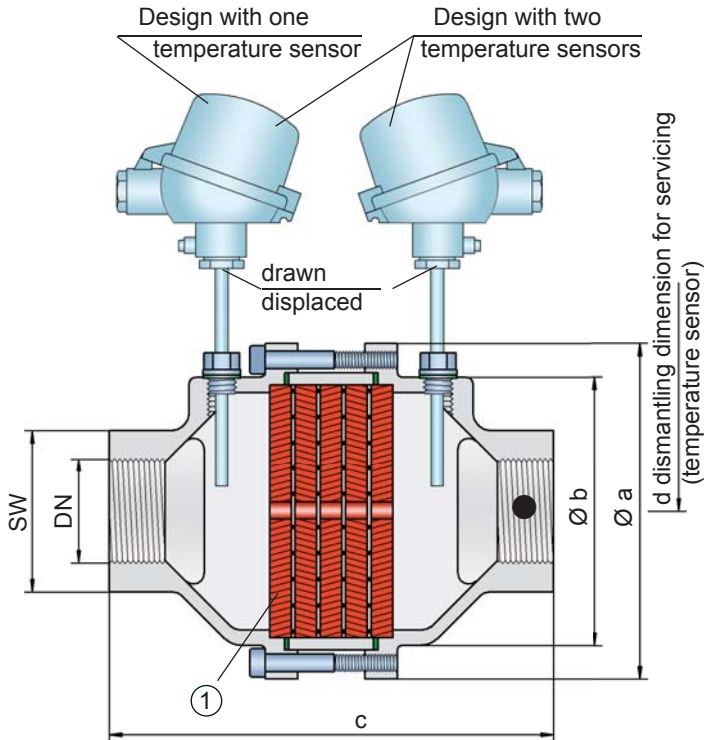

● Connection to the protected side
(only for type DA-G-T-...)

that can be used for all explosion groups, IIA, IIB3 and IIC (NEC Group D, C MESH ≥ 0.65 mm and B). The standard design can be used up to an operating temperature of $+60^{\circ}\text{C}$ / 140°F and an absolute operating pressure up to 1.1 bar / 15.9 psi. **Devices with special approvals can be obtained for higher pressures (see table 4) and higher temperatures upon request.**

The device is bidirectional and equipped with a threaded connection. The thread can be executed to international standards. The detonation arrester can be used at any location in the pipe, independently from the location of the ignition source.

Type-approved in accordance with the current ATEX Directive and EN ISO 16852 as well as other international standards.

Special Features and Advantages

- bidirectional
- modular design
- the individual FLAMEFILTER® discs can be quickly removed and installed
- the individual FLAMEFILTER® discs are easy to service and replace
- different application possibilities
- use of temperature sensors for G 1½ and G 2 is possible
- cost efficient spare parts

Design Types and Specifications

There are three different designs available:

Basic design of the DA-G in-line detonation flame arrester, size 1½" to 2" **DA-G-**

In-line detonation flame arrester with integrated temperature sensor* as additional protection against short burning from one side, size 1½" to 2" **DA-G-** **T**

In-line detonation flame arrester with two integrated temperature sensors* as additional protection against short time burning from both sides, size 1½" to 2" **DA-G-** **TB**

*Resistance thermometer for device group II, category (1) 2 (GII cat. (1) 2)

Flange connection available upon request

Function and Description

The PROTEGO® DA-G series is a compact in-line detonation flame arrester for installation in pipes with diameters up to 2", and is used, for example, in industrial applications such as gas analyzing lines.

Once a detonation enters the flame arrester, energy is absorbed from the shock wave, and the flame is extinguished in the narrow gaps of the FLAMEFILTER® (1).

The PROTEGO® flame arrester unit consists of several FLAMEFILTER® discs firmly held in a housing. The gap size and number of FLAMEFILTER® discs are determined by the operating data and parameters of the mixture flowing in the line (explosion group, pressure, temperature).

To provide an optimum result between the housing size, number of FLAMEFILTER® discs and their gap size, a device was developed

Table 1: Dimensions

Dimensions in mm / inches, SW = width across flats

To select the nominal size (DN), please use the flow capacity charts on the following pages

DN	G ½	G ¾	G 1	G 1 ¼	G 1 ½	G 2
a	80 / 3.15	80 / 3.15	100 / 3.94	100 / 3.94	155 / 6.10	155 / 6.10
b	55 / 2.17	55 / 2.17	76 / 2.99	76 / 2.99	124 / 4.88	124 / 4.88
c (IIA)	112 / 4.41	112 / 4.41	122 / 4.80	122 / 4.80	205 / 8.07	205 / 8.07
c (IIB3 and IIC)	135 / 5.31	135 / 5.31	145 / 5.71	145 / 5.71	205 / 8.07	205 / 8.07
d	—	—	—	—	400 / 15.75	400 / 15.75
SW	32 / 1.26	32 / 1.26	50 / 1.97	50 / 1.97	75 / 2.95	75 / 2.95

Table 2: Selection of the explosion group

MESG	Expl. Gr. (IEC/CEN)	Gas Group (NEC)	Special approvals upon request
> 0,90 mm	IIA	D	
≥ 0,65 mm	IIB3	C	
< 0,50 mm	IIC	B	

Table 3: Selection of max. operating pressure

		DN	G ½	G ¾	G 1	G 1 ¼	G 1 ½	G 2	P _{max} = maximum allowable operating pressure in bar / psi (absolute), higher operating pressure upon request
Expl. Gr.	IIA	P _{max}	1.2/17.4	1.2/17.4	1.1/15.9	1.1/15.9	1.1/15.9	1.1/15.9	
	IIB3	P _{max}	1.1/15.9	1.1/15.9	1.1/15.9	1.1/15.9	1.4/20.3	1.4/20.3	
	IIC	P _{max}	1.1/15.9	1.1/15.9	1.1/15.9	1.1/15.9	1.6/23.2	1.6/23.2	

Table 4: Specification of max. operating temperature

≤ 60°C / 140°F	T _{maximum allowable operating temperature in °C}	higher operating temperatures upon request
-	Designation	

Table 5: Material selection

Design	B	C	* the FLAMEFILTER® is also available in the materials Tantalum, Inconel, Copper, etc. when the listed housing materials are used.
Housing	Stainless Steel	Hastelloy	
Gasket	PTFE	PTFE	
FLAMEFILTER®*	Stainless Steel	Hastelloy	

Special materials upon request

Table 6: Type of connection

Pipe thread DIN ISO 228-1	DIN	other types of thread upon request
---------------------------	-----	------------------------------------



for safety and environment

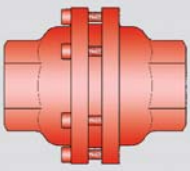

In-Line Detonation Flame Arrester

Flow Capacity Charts

PROTEGO® DA-G

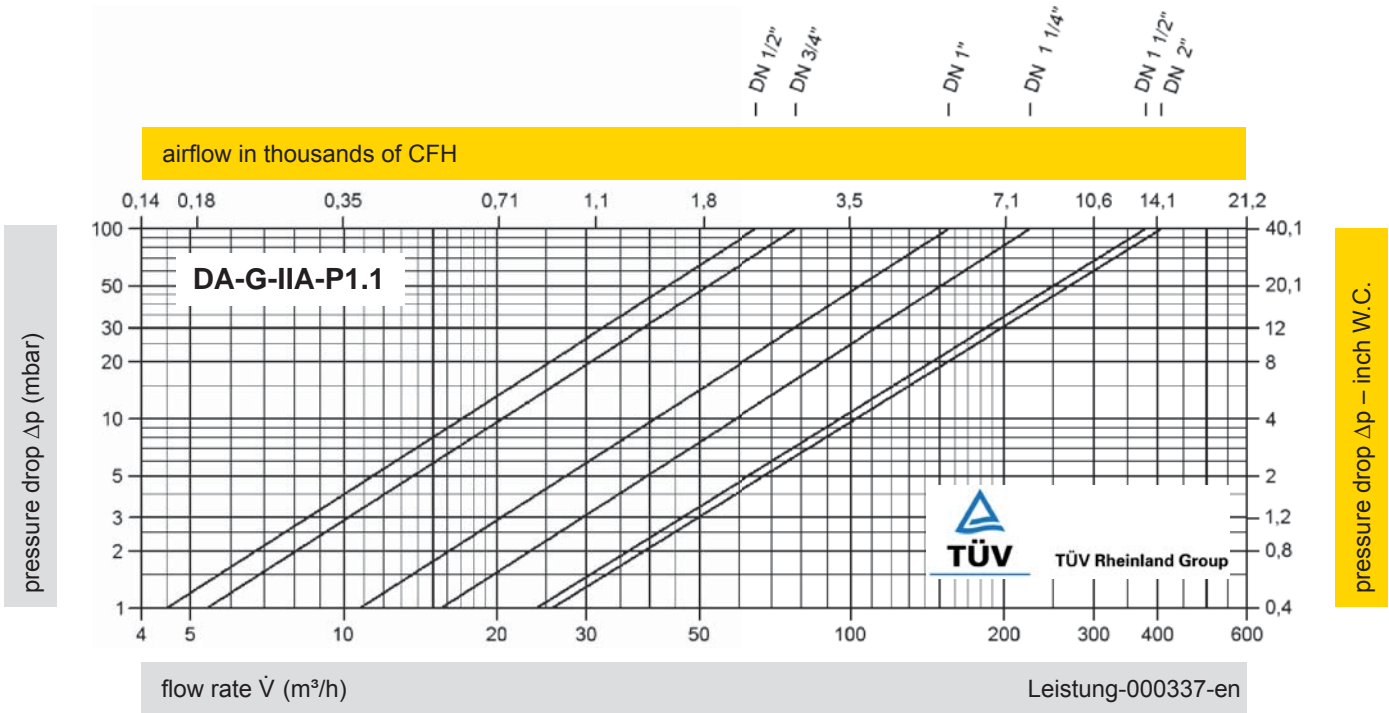

* P1.4

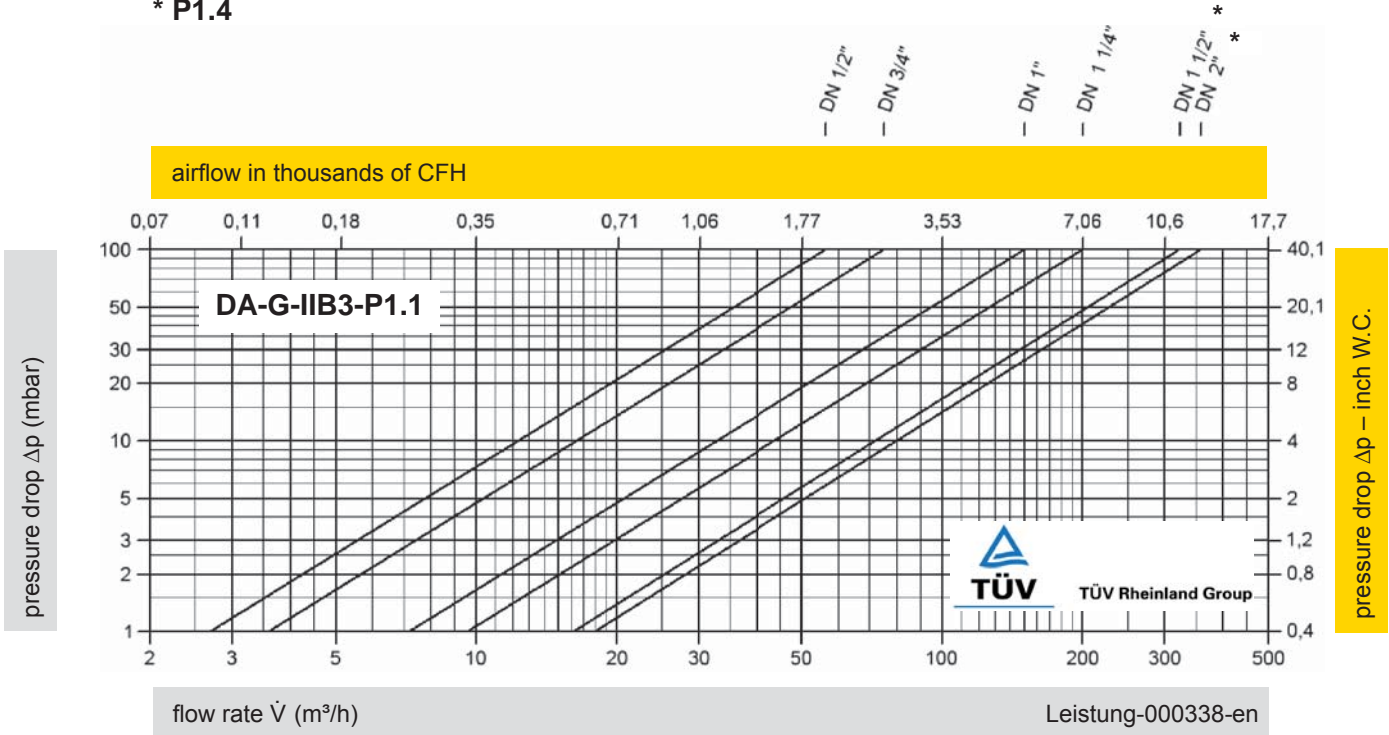

The flow capacity charts have been determined with a calibrated and TÜV certified flow capacity test rig. Volume flow \dot{V} in (m³/h) and CFH refer to the standard reference conditions of air ISO 6358 (20°C, 1bar). Conversion to other densities and temperatures refer to Vol. 1: "Technical Fundamentals".

* P1.6

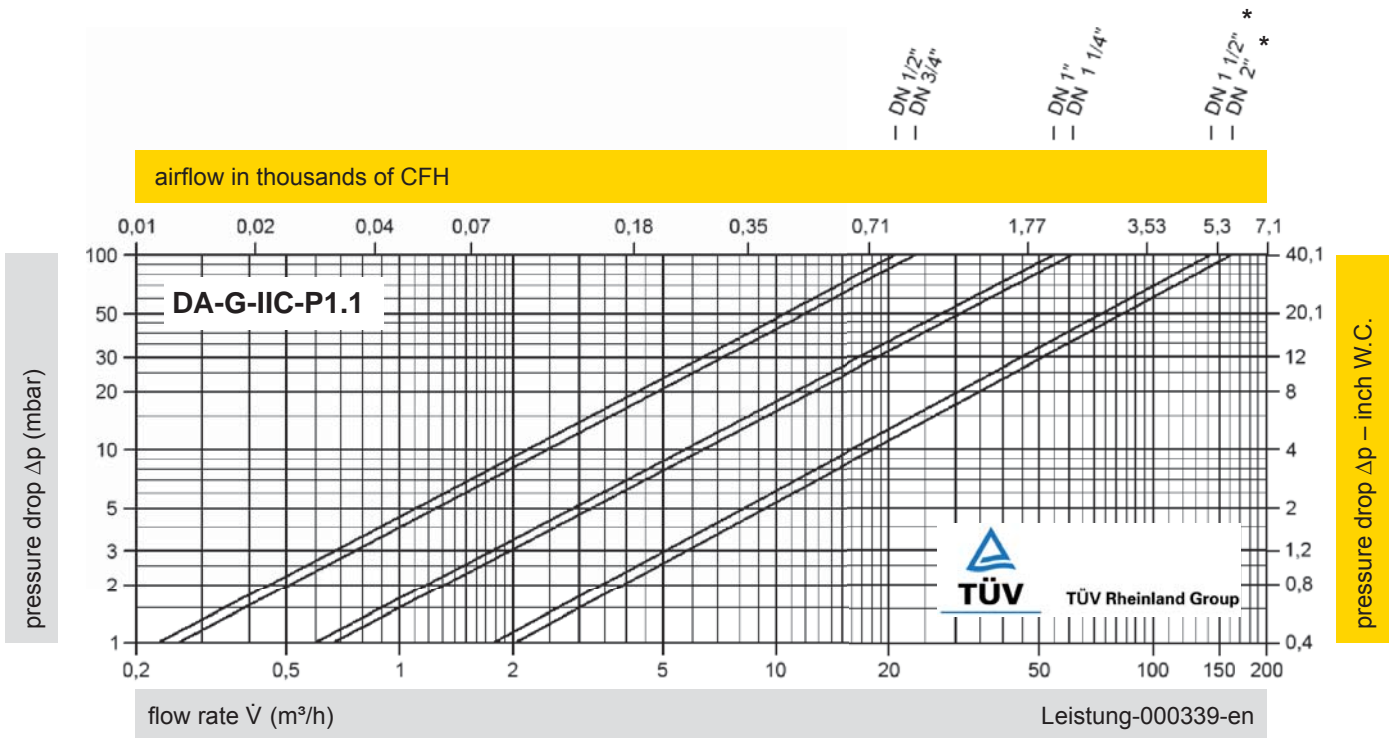

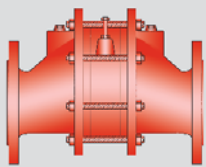

Eccentric In-Line Detonation Flame Arrester

for stable detonations and deflagrations in a straight through design,
bidirectional

PROTEGO® DA-E

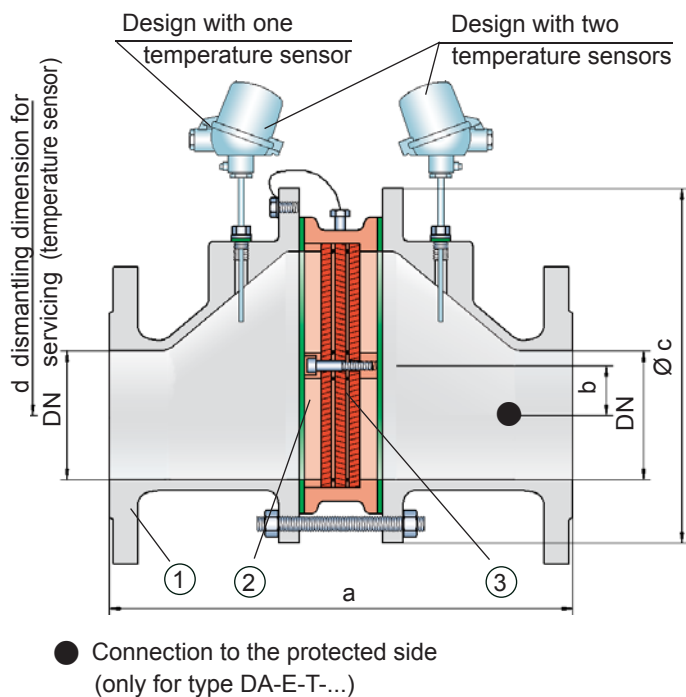

Function and Description

The PROTEGO® DA-E series of detonation arresters is distinguished by its eccentric housing shape. When condensate accumulates within the PROTEGO® flame arrester unit, the design enables the liquid to drain without collecting large amounts in the housing. The eccentric design of the device has decisive advantages in comparison to the classic flame arresters when pipes are installed close to ground level.

The detonation arrester is symmetrical and offers bidirectional flame arresting. The arrester essentially consists of two housing parts (1) and the PROTEGO® flame arrester unit (2) in the center. The PROTEGO® flame arrester unit consists of several FLAMEFILTER® discs (3) and spacers firmly held in a FLAMEFILTER® cage. The number of FLAMEFILTER® discs and their gap size depends on the arrester's conditions of use. By indicating the operating parameters such as temperature, pressure and explosion group and the composition of the fluid, the optimum detonation arrester

can be selected. The PROTEGO® DA-E series of flame arresters is available for explosion groups IIA to IIB3 (NEC Group D to C MESH ≥ 0.65 mm).

The standard design can be used up to an operating temperature of +60°C / 140°F and an absolute operating pressure acc. to table 3. **Devices with special approval can be obtained for higher pressures and higher temperatures upon request.**

Type-approved in accordance with the current ATEX Directive and EN ISO 16852 as well as other international standards.

Special Features and Advantages

- eccentric design prevents the collection of condensate
- the modular design enables each individual FLAMEFILTER® discs to be replaced
- easy maintenance with quick removal and installation of FLAMEFILTER® discs
- eccentric design allows installation in close to ground level
- bidirectional operation as well as any flow direction and installation position
- protects from deflagration and stable detonation
- installation of temperature sensors possible
- cost efficient spare parts

Design Types and Specifications

There are three different designs available:

Basic design of the detonation arrester **DA-E-**

In-line detonation flame arrester with integrated temperature sensor* as additional protection against short time burning of one side **DA-E-**

Detonation arrester with two integrated temperature sensors* as additional protection against short time burning from both sides **DA-E-**

Additional special arresters upon request

*Resistance thermometer for device group II, category (1) 2 (GII cat. (1) 2)



Table 1: Dimensions

Dimensions in mm / inches

To select the nominal size (DN), please use the flow capacity charts on the following pages

DN		25 1"	32 1 ¼"	40 1 ½"	50 2"	65 2 ½"	80 3"	100 4"	125 5"	150 6"	200 8"	250 10"	300 12"	
Expl. Gr.	IIA	a	304/315* / 11.97/12.4*	304/315* / 11.97/12.4*	320/ 12.60	325/ 12.80	370/ 14.57	375/ 14.76	380/ 14.96	481/ 18.94	487/ 19.17	510/ 20.08	540/ 21.26	560/ 22.05
	IIB3	a	304/ 11.97	304/ 11.97	357/ 14.06	361/ 14.21	408/ 16.06	412/ 16.22	428/ 16.85	493/ 19.41	499/ 19.65	522/ 20.55	552/ 21.73	572/ 22.52
		b	29/ 1.14	29/ 1.14	29/ 1.14	29/ 1.14	38/ 1.50	38/ 1.50	39/ 1.53	65/ 2.56	65/ 2.56	55/ 2.17	58/ 2.28	60/ 2.36
		c	185/ 7.28	185/ 7.28	210/ 8.27	210/ 8.27	250/ 9.84	250/ 9.84	275/ 10.83	385/ 15.16	385/ 15.16	450/ 17.72	500/ 19.69	575/ 22.64
		d	400/ 15.75	400/ 15.75	410/ 16.14	410/ 16.14	440/ 17.32	440/ 17.32	460/ 18.11	520/ 20.47	520/ 20.47	540/ 21.26	570/ 22.44	600/ 23.62

* for IIA-P2.0

Table 2: Selection of the explosion group

MESG	Expl. Gr. (IEC/CEN)	Gas Group (NEC)	Special approvals upon request
> 0,90 mm	IIA	D	
≥ 0,65 mm	IIB3	C	

Table 3: Selection of max. operating pressure

DN		25 1"	32 1 ¼"	40 1 ½"	50 2"	65 2 ½"	80 3"	100 4"	125 5"	150 6"	200 8"	250 10"	300 12"
Expl. Gr.	IIA	P _{max}	2.0 / 29.0	2.0 / 29.0	1.2 / 17.4	1.2 / 17.4	1.2 / 17.4	1.2 / 17.4	1.2 / 17.4	1.2 / 17.4	1.2 / 17.4	1.2 / 17.4	1.2 / 17.4
	IIB3	P _{max}	1.1 / 15.9	1.1 / 15.9	1.2 / 17.4	1.2 / 17.4	1.2 / 17.4	1.2 / 17.4	1.2 / 17.4	1.2 / 17.4	1.2 / 17.4	1.2 / 17.4	1.2 / 17.4

P_{max} = maximum allowable operating pressure in bar / psi (absolute), higher operating pressure upon request

Table 4: Specification of max. operating temperature

≤ 60°C / 140°F	Tmaximum allowable operating temperature in °C	higher operating temperatures upon request
-	Designation	

Table 5: Material selection for housing

Design	B	C	D	The housing is also available in carbon steel with an ECTFE coating.
Housing	Steel	Stainless Steel	Hastelloy	
Gasket	PTFE	PTFE	PTFE	
Flame arrester unit	A, C	C	D	

Special materials upon request

Table 6: Material combinations of the flame arrester unit

Design	A	C	D	*the FLAMEFILTER® are also available in the materials Tantalum, Inconel, Copper, etc. when the listed housing and cage materials are used.
FLAMEFILTER® cage	Steel	Stainless Steel	Hastelloy	
FLAMEFILTER® *	Stainless Steel	Stainless Steel	Hastelloy	
Spacer	Stainless Steel	Stainless Steel	Hastelloy	

Special materials upon request

Table 7: Flange connection type

EN 1092-1; Form B1	other types upon request
ASME B16.5; 150 lbs RFSF	



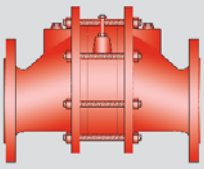

Eccentric In-Line Detonation Flame Arrester

Flow Capacity Charts

PROTEGO® DA-E

* P1.3

DN 25 / 1" *
DN 32 / 1 1/4" *
DN 40 / 1 1/2"
DN 50 / 2"
DN 65 / 2 1/2"
DN 80 / 3"
DN 100 / 4"
DN 125 / 5"
DN 150 / 6"
DN 200 / 8"
DN 250 / 10"
DN 300 / 12"

airflow in thousands of CFH

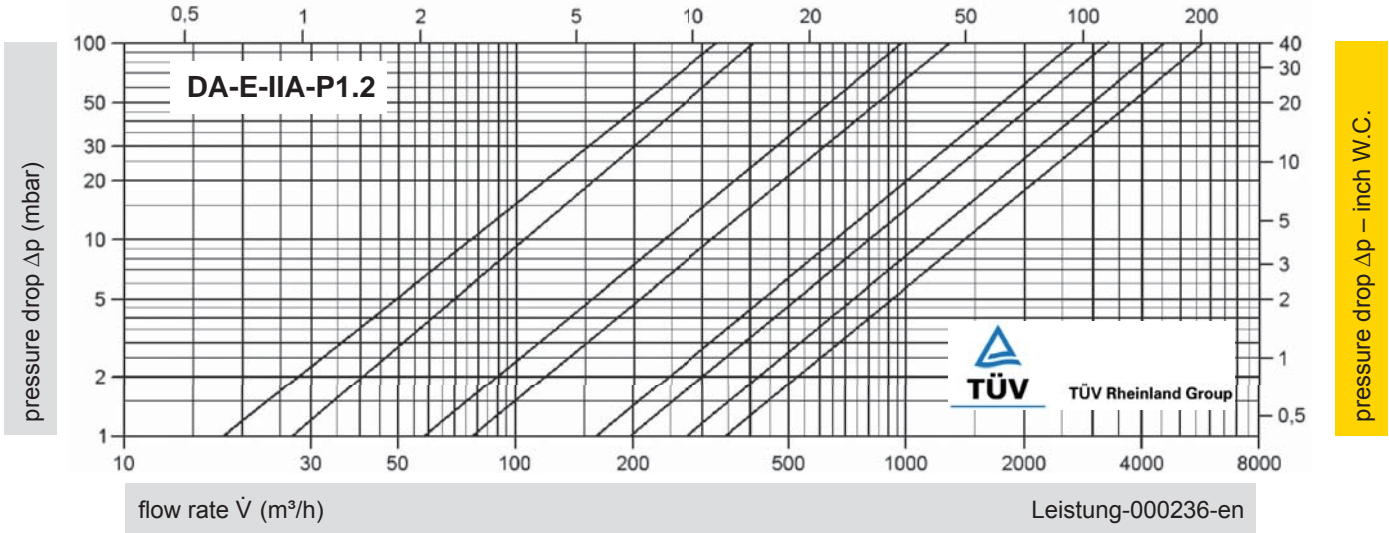

* P1.1

DN 25 / 1" *
DN 32 / 1 1/4" *
DN 40 / 1 1/2"
DN 50 / 2"
DN 65 / 2 1/2"
DN 80 / 3"
DN 100 / 4"
DN 125 / 5"
DN 150 / 6"
DN 200 / 8"
DN 250 / 10"
DN 300 / 12"

airflow in thousands of CFH

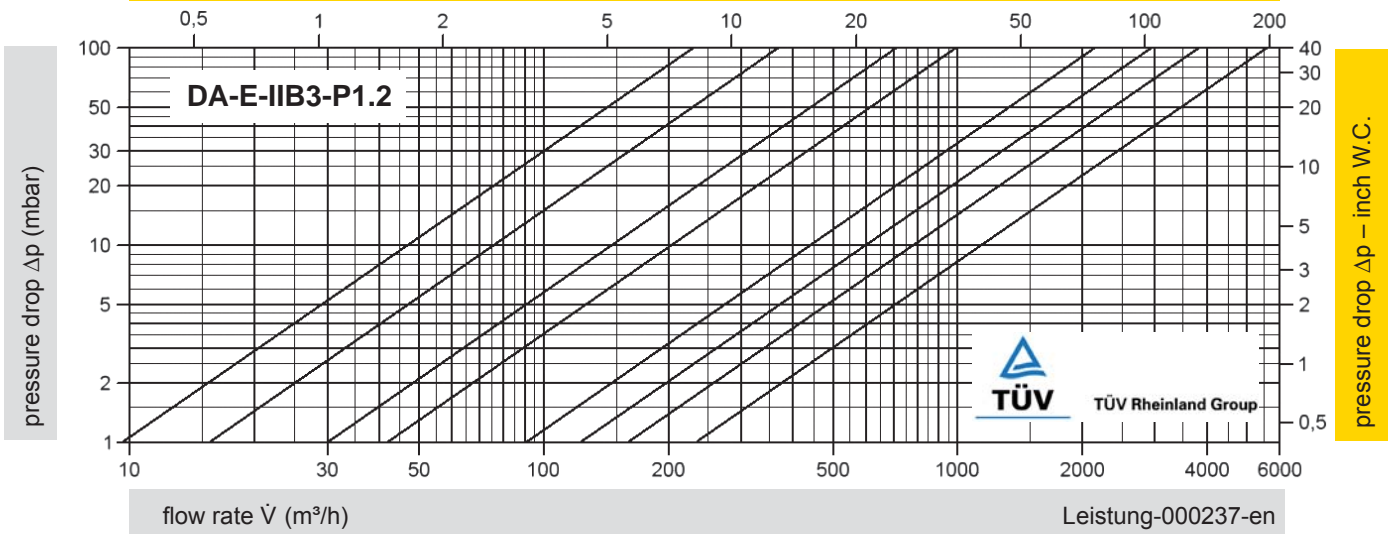

The flow capacity charts have been determined with a calibrated and TÜV certified flow capacity test rig. Volume flow \dot{V} in (m³/h) and CFH refer to the standard reference conditions of air ISO 6358 (20°C, 1bar). Conversion to other densities and temperatures refer to Vol. 1: "Technical Fundamentals".

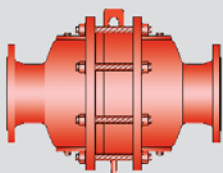

In-Line Detonation Flame Arrester

for stable detonations and deflagrations in a straight through design with shock tube, bidirectional

PROTEGO® DA-SB

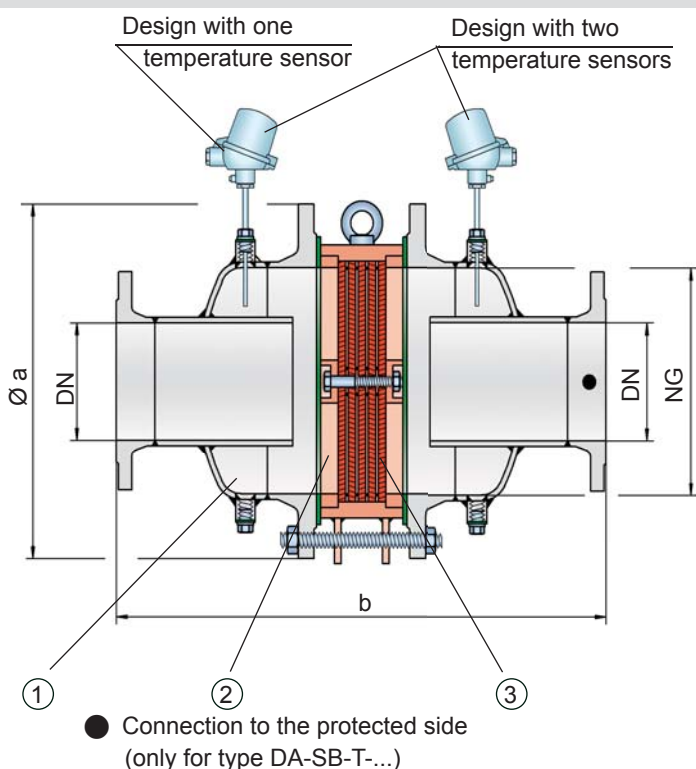

Function and Description

The in-line detonation flame arresters type PROTEGO® DA-SB are the newest generation of flame arresters. On the basis of fluid dynamic, explosion dynamics calculation and decades of experience from field tests, a product line was developed that offers minimum pressure loss and maximum safety. The flame arrester uses the *Shock Wave Guide Tube Effect (SWGTE)* to separate the flame front and shock wave. The result is an in-line detonation arrester without a classic shock absorber; in addition the use of FLAMEFILTER® discs is minimized.

The devices are symmetrical and offer bidirectional flame arresting for deflagrations and stable detonations. The arrester essentially consists of two housing parts with an integrated shock tube (1) and the PROTEGO® flame arrester unit (2) in the center. The PROTEGO® flame arrester unit is modular and consists of several FLAMEFILTER® discs (3) and spacers firmly held in a FLAMEFILTER® cage. The number of FLAMEFILTER® discs and their gap size depends on the arrester's conditions of use.

By indicating the operating parameters such as temperature, pressure and explosion group, and the composition of the fluid, the optimum detonation arrester can be selected from a series of approved devices. The PROTEGO® DA-SB flame arresters are available for all explosion groups.

The standard design can be used up to an operating temperature of +60°C / 140°F and an absolute operating pressure up to 1.1 bar / 15.9 psi. **Numerous devices with special approval can be obtained for higher pressures (see table 3) and higher temperatures.**

c dismantling dimension for servicing (temperature sensor)

Type-approved in accordance with the current ATEX Directive and EN ISO 16852 as well as other international standards.

Special Features and Advantages

- optimized performance from the patented *Shock Wave Guide Tube Effect (SWGTE)*
- less number of FLAMEFILTER® discs from the use of the patented shock tube (SWGTE)
- modular flame arrester unit enables each individual FLAMEFILTER® discs to be replaced and cleaned
- different series allow increase of FLAMEFILTER® size for given flange connection resulting in lower pressure drop across the device
- service-friendly design
- expanded application range for higher operating temperatures and pressures
- bidirectional operation as well as any direction of flow and installation position
- installation of temperature sensors are possible
- minimum pressure loss and associated low operating and life-cycle cost
- cost efficient spare parts
- use of stabilized FLAMEFILTER® discs is possible
- use of PROTEGO® Flame Arrester Unit in unique maintenance friendly design reduces service cost

NEW

Design Types and Specifications

There are four different designs available:

- Basic in-line detonation flame arrester **DA-SB - [] - []**
- In-line detonation flame arrester with integrated temperature sensor* as additional protection against short time burning from one side **DA-SB - [T] - []**
- In-line detonation flame arrester with two integrated temperature sensors* for additional protection against short time burning from both sides **DA-SB - [TB] - []**
- In-line detonation flame arrester with heating jacket **DA-SB - [H] - []**

Additional special flame arresters upon request

*Resistance thermometer for device group II, category (1) 2 (GII cat. (1) 2)



Stabilized FLAMEFILTER®
Discs (Flyer pdf)



New PROTEGO® Flame Arrester Unit unique
maintenance friendly design (Flyer pdf)

Table 1: Dimensions

Dimensions in mm / inches

To select nominal width/nominal size (NG/DN) - combination, please use the flow capacity charts on the following pages		Additional nominal width/nominal size (NG/DN) - combinations for improved flow capacity upon request										
standard (special sizes up to NG 2000/80", DN 1000/40" available)												
NG	150 6"	150 6"	200 8"	300 12"	400 16"	500 20"	600 24"	700 28"	800 32"	1000 40"	1200 48"	1600 64"
DN	≤ 50 2"	65, 80 2 1/2", 3"	≤ 100 4"	≤ 150 6"	≤ 200 8"	≤ 250 10"	≤ 300 12"	≤ 350 14"	≤ 400 16"	≤ 500 20"	≤ 600 24"	800 32"
a	285 / 11.22	285 / 11.22	340 / 13.39	445 / 17.52	565 / 22.24	670 / 26.38	780 / 30.71	895 / 35.24	1015 / 39.96	1230 / 48.43	1455 / 57.28	1915 / 75.39
IIA-P1,1	388 / 15.28	388 / 15.28	476 / 18.74	626 / 24.65	700 / 27.56	800 / 31.50*	1000 / 39.37*	1200 / 47.24	1400 / 55.12	1600 / 62.99	1800 / 70.87	2200/ 86.61**
IIA-P1,4-X3	400 / 15.75	400 / 15.75	488 / 19.21	626 / 24.65	724 / 28.50	800 / 31.50	1000 / 39.37	1200 / 47.24	1400 / 55.12			
b												
IIB3-P1,1	400 / 15.75	412 / 16.22	500 / 19.69	650 / 25.59	724 / 28.50	824 / 32.44	1000 / 39.37	1200 / 47.24	1400 / 55.12	1600 / 62.99	1800 / 70.87	
IIB3-P1,4-X3	412 / 16.22	412 / 16.22	512 / 20.16	650 / 25.59	724 / 28.50	824 / 32.44	1000 / 39.37	1200 / 47.24	1400 / 55.12			
IIC-P1,1	400 / 15.75	400 / 15.75	500 / 19.69	638 / 25.12	700 / 27.56	788 / 31.02	1000 / 39.37***	1200 / 47.24***	1400 / 55.12***			
c												
	500 / 19.69	500 / 19.69	520 / 20.47	570 / 22.44	620 / 24.41	670 / 26.38	720 / 28.35	770 / 30.31	820 / 32.28	950 / 37.40	1050 / 41.34	1250 / 49.21

* dimension b only for P1.4 / 20.3

** dimension b only for P1.2 / 17.4

*** EN 12874

Table 2: Selection of the explosion group

MESG	Expl. Gr. (IEC/CEN)	Gas Group (NEC)	Special approvals upon request
> 0,90 mm	IIA	D	
≥ 0,65 mm	IIB3	C	
< 0,50 mm	IIC	B	

Table 3: Selection of max. operating pressure

NG		150 6"	150 6"	200 8"	300 12"	400 16"	500 20"	600 24"	700 28"	800 32"	1000 40"	1200 48"	1600 64"	
DN		≤ 50 2"	65, 80 2 1/2", 3"	≤ 100 4"	≤ 150 6"	≤ 200 8"	≤ 250 10"	≤ 300 12"	≤ 350 14"	≤ 400 16"	≤ 500 20"	≤ 600 24"	800 32"	
Expl. Gr.	IIA	P _{max}	2.1 / 30.5	2.1 / 30.5	2.1 / 30.5	2.1 / 30.5	2.1 / 30.5	2.1 / 30.5	1.4 / 20.3	1.4 / 20.3	1.4 / 20.3	1.1 / 15.9	1.1 / 15.9	1.2 / 17.4
	IIB3	P _{max}	1.4 / 20.3	1.4 / 20.3	1.4 / 20.3	1.8 / 26.1	1.8 / 26.1	1.8 / 26.1	1.8 / 26.1	1.4 / 20.3	1.4 / 20.3	1.1 / 15.9	1.1 / 15.9	
	IIC	P _{max}	2.2 / 31.9	2.2 / 31.9	1.1 / 15.9	1.1 / 15.9	1.1 / 15.9	1.1 / 15.9	1.1 / 15.9	1.1 / 15.9	1.1 / 15.9			

P_{max} = maximum allowable operating pressure in bar / psi absolut, higher operating pressure upon request

in-between size up to P_{max} upon request

* capacity charts upon request

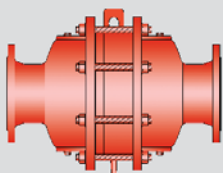

In-Line Detonation Flame Arrester

for stable detonations and deflagrations in a straight through design with shock tube, bidirectional

PROTEGO® DA-SB

Table 4: Specification of max. operating temperature

≤ 60°C / 140°F	≤ 200°C / 392°F	Tmaximum allowable operating temperature in °C	higher operating temperatures upon request
-	X3	Designation	

Table 5: Material selection for housing

Design	A	B	C	The housing is also available in Steel with ECTFE coating.
Housing	Steel	Stainless Steel	Hastelloy	
Heating jacket (DA-SB-(T)-H-...)	Steel	Stainless Steel	Stainless Steel	
Gasket	PTFE	PTFE	PTFE	
Flame arrester unit	A, B	B, C, D	D	

Special materials upon request

Table 6: Material combinations of the flame arrester unit

Design	A	B	C	D	*the FLAMEFILTER® are also available in the materials Tantalum, Inconel, Copper, etc. when the listed housing and cage materials are used.
FLAMEFILTER® cage	Steel	Stainless Steel	Stainless Steel	Hastelloy	
FLAMEFILTER® *	Stainless Steel	Stainless Steel	Hastelloy	Hastelloy	
Spacer	Stainless Steel	Stainless Steel	Hastelloy	Hastelloy	

Special materials upon request

Table 7: Flange connection type

EN 1092-1; Form B1	other types upon request
ASME B16.5; 150 lbs RFSF	

* P1.4
** P1.2

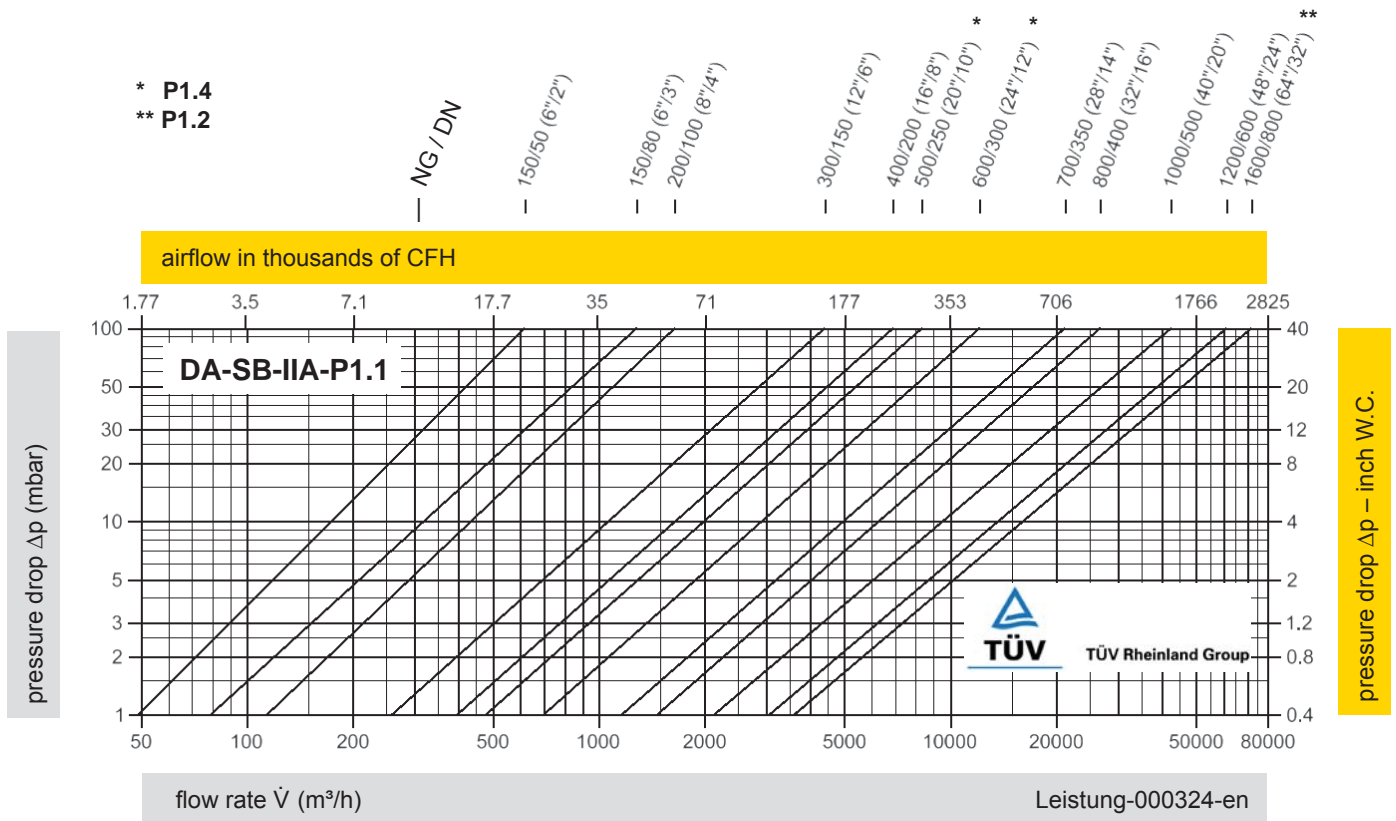

X3 maximum allowable operating temperature 200 °C

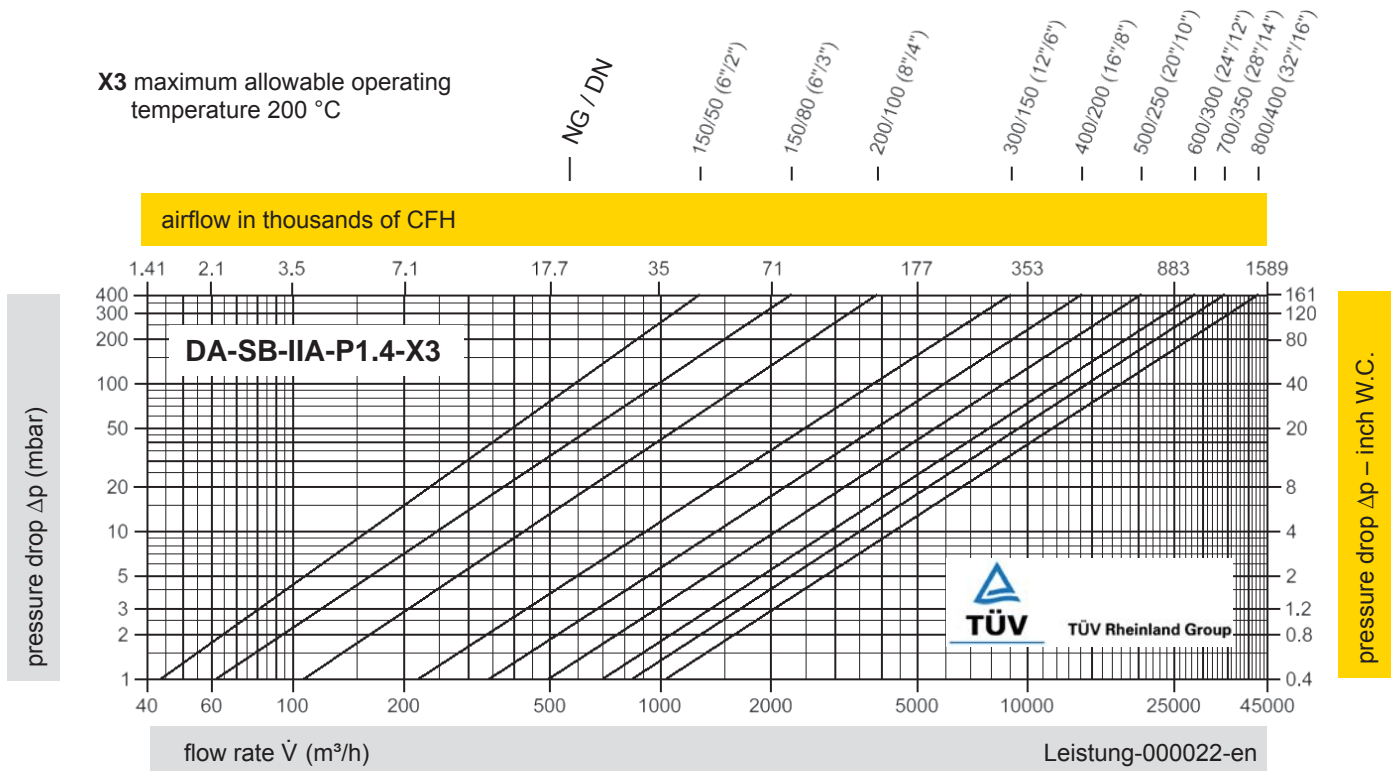

The flow capacity charts have been determined with a calibrated and TÜV certified flow capacity test rig. Volume flow \dot{V} in (m³/h) and CFH refer to the standard reference conditions of air ISO 6358 (20°C, 1bar). Conversion to other densities and temperatures refer to Vol. 1: "Technical Fundamentals".



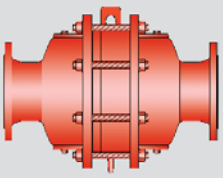

In-Line Detonation Flame Arrester

Flow Capacity Charts

PROTEGO® DA-SB

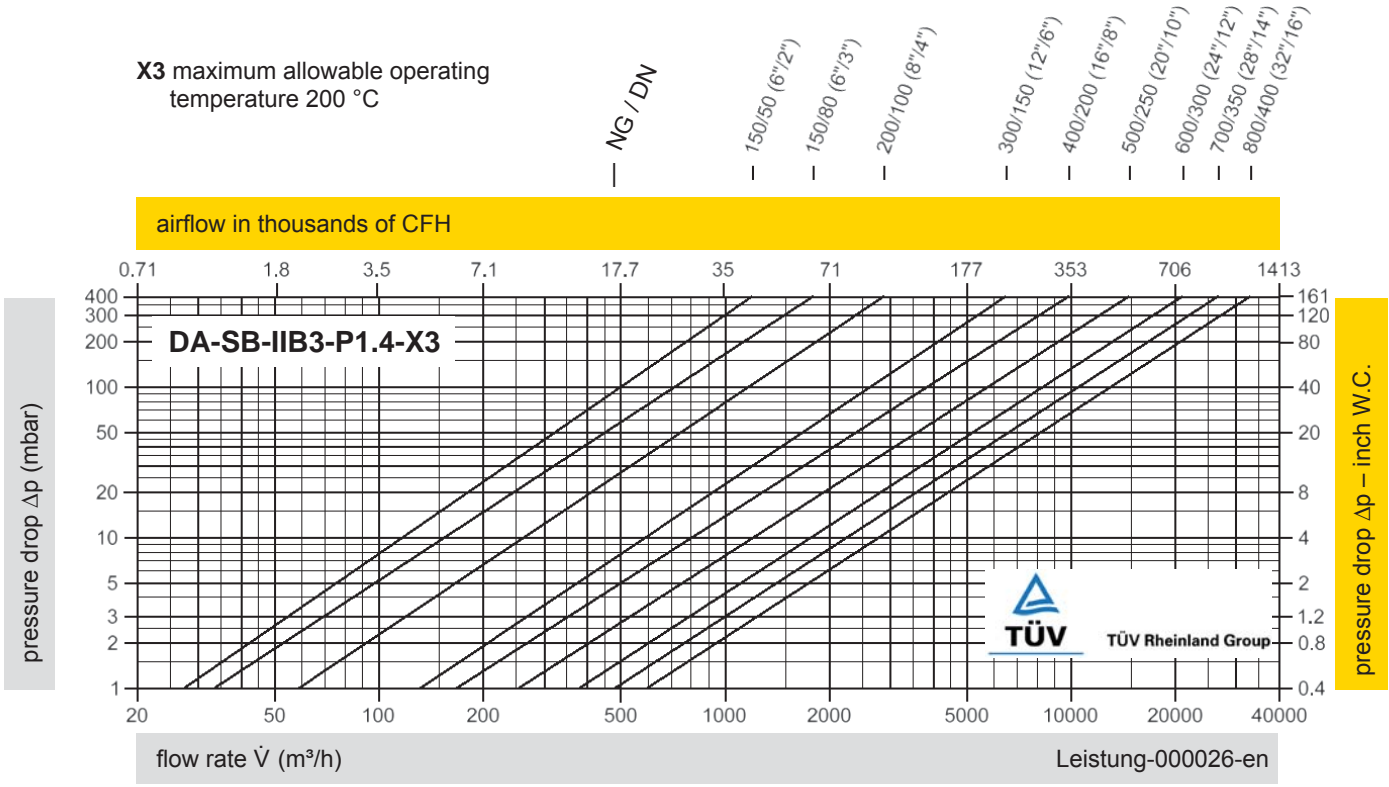
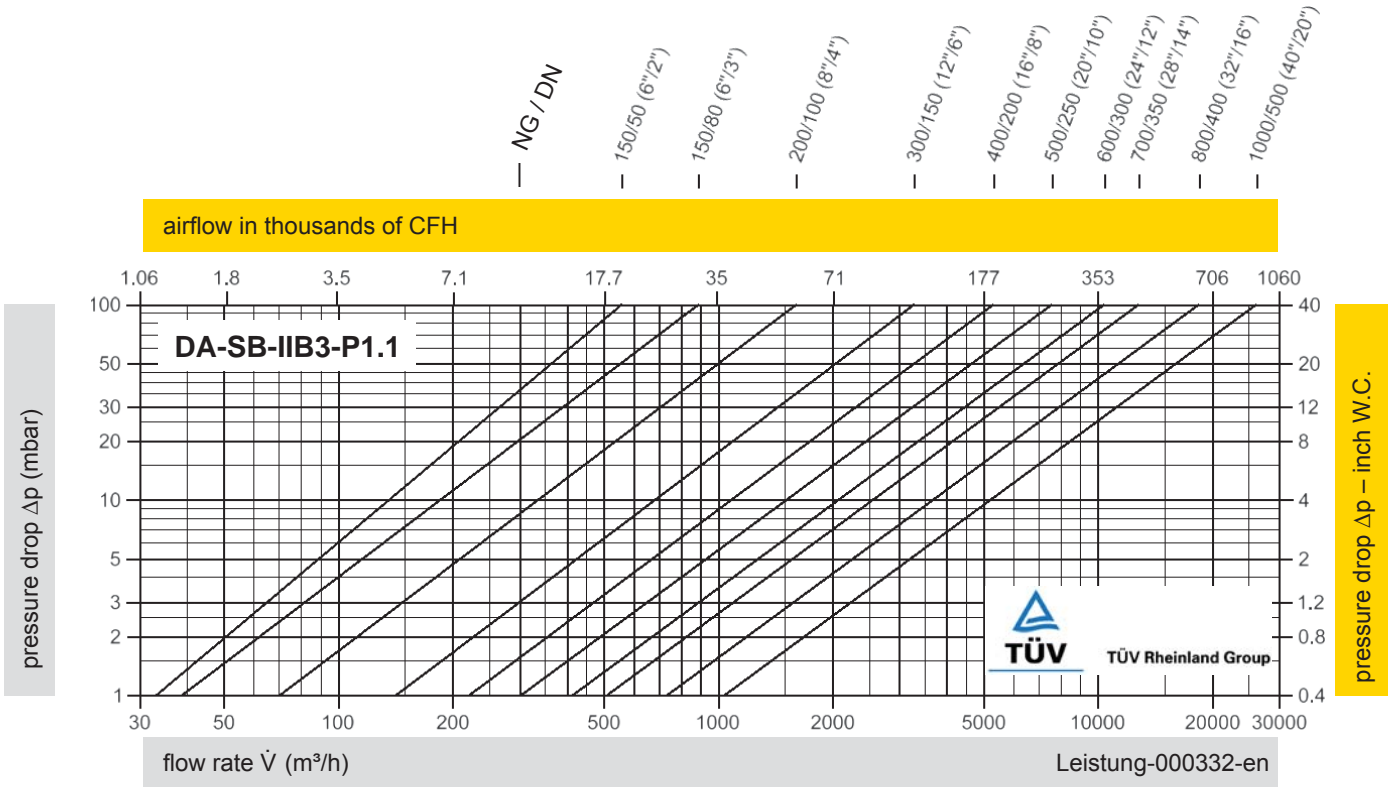

The flow capacity charts have been determined with a calibrated and TÜV certified flow capacity test rig. Volume flow \dot{V} in (m³/h) and CFH refer to the standard reference conditions of air ISO 6358 (20°C, 1bar). Conversion to other densities and temperatures refer to Vol. 1: "Technical Fundamentals".

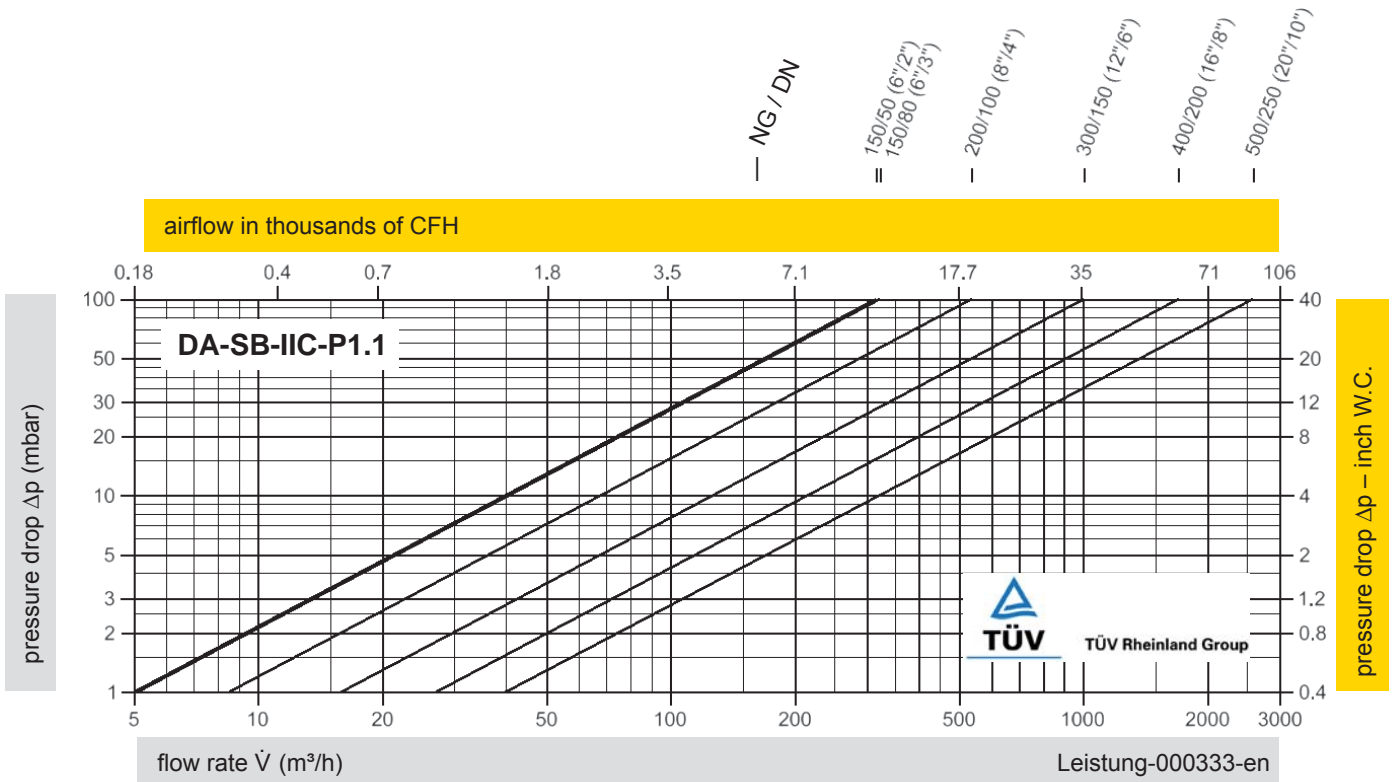

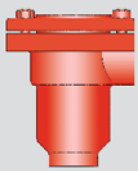

In-Line Detonation Flame Arrester

for stable detonations and deflagrations in right angle design,
unidirectional

PROTEGO® DR/ES

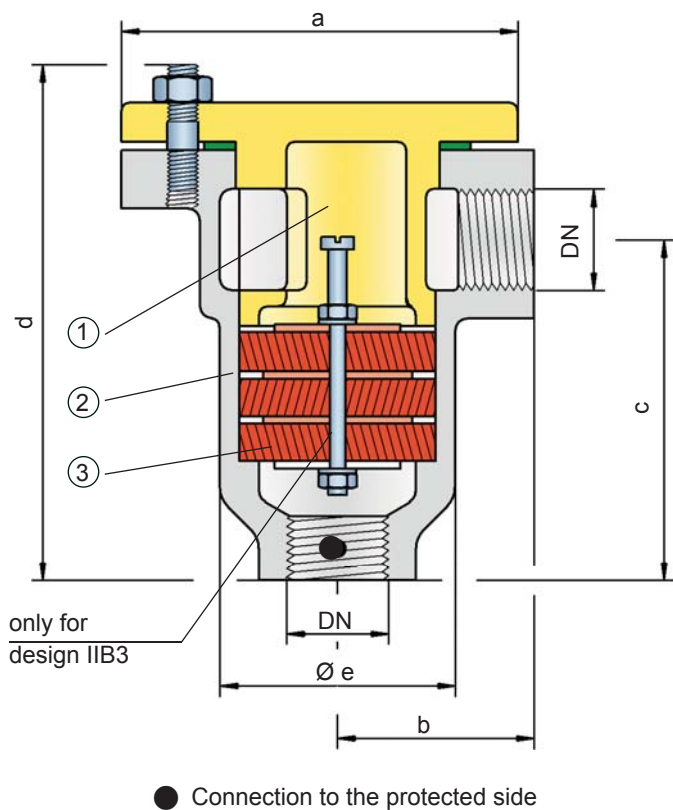

The PROTEGO® flame arrester unit (2) consists of several FLAMEFILTER® discs and spacers (for explosion group IIC - NEC group B) whose gap size and number is determined by the operating parameters of the processed fluid (explosion group, pressure, temperature). This device is available for explosion groups IIB3 and IIC (NEC group C MESH \geq 0.65 mm and B).

This in-line detonation flame arrester functions unidirectional and is equipped with a threaded connection. The thread can be adapted to international standards. The standard design is approved at an operating temperature up to +60°C / 140°F and an absolute operating pressure acc. to table 3. **Devices with special approvals can be obtained for higher pressures and higher temperatures upon request.**

Type-approved in accordance with the current ATEX Directive and EN ISO 16852 as well as other international standards.

Special Features and Advantages

- compact design
- minimum number of FLAMEFILTER® discs due to shock absorber technology and optimal geometry
- Design for IIB3:
 - the device can be serviced without disconnecting the pipe
 - the individual FLAMEFILTER® can be quickly removed and installed
- provides protection from deflagration and stable detonation
- through right angle design no pipe elbows are needed
- works for nearly any flammable gas and gas mixture
- low life-cycle cost
- cost efficient spare parts

Function and Description

The PROTEGO® DR/ES series in-line detonation flame arrester with connection size up to 3/4" is ideal for installation in small pipes and to protect equipment such as gas analyzers. The device protects against deflagrations and stable detonations. It can be installed anywhere in the pipe no matter what the distance is from the potential ignition source. The small and compact flame arrester has a right angle design.

Once a detonation enters the flame arrester, energy is absorbed from the detonation shock wave by diversion mainly through the shock absorber (1) before the flame is extinguished in the narrow gaps of the FLAMEFILTER® (3).

Table 1: Dimensions

Dimensions in mm / inches

To select the nominal size (DN), please use the flow capacity charts on the following pages

DN	G ¼	G ½	G¾
a	48 / 1.89	70 / 2.76	80 / 3.15
b	35 / 1.38	40 / 1.57	47 / 1.85
c	70 / 2.76	75 / 2.95	87 / 3.43
d	108 / 4.25	115 / 4.53	135 / 5.31
e	34 / 1.34	50 / 1.97	60 / 2.36

Table 2: Selection of the explosion group

MESG	Expl. Gr. (IEC/CEN)	Gas Group (NEC)	Special approvals upon request
≥ 0,65 mm	IIB3	C	
< 0,50 mm	IIC	B	

Table 3: Selection of max. operating pressure

Expl. Gr.	DN		G¼	G ½	G¾	P _{max} = maximum allowable operating pressure in bar / psi (absolute), higher operating pressure upon request Expl. Gr. IIB3 covers Expl. Gr. IIA
	IIB3	P _{max}	1.2 / 17.4	1.2 / 17.4	1.2 / 17.4	
IIC	P _{max}	1.1 / 15.9	1.1 / 15.9	1.1 / 15.9	1.1 / 15.9	

Table 4: Specification of max. operating temperature

≤ 60°C / 140°F	T _{maximum allowable operating temperature in °C}	higher operating temperatures upon request
-	Designation	

Table 5: Material selection for housing

Design	B	C	D	G ¼ only comes in design C and D * G ¼ without shock absorber
Housing	Steel	Stainless Steel	Hastelloy	
Cover with shock absorber*	Steel	Stainless Steel	Hastelloy	
Gasket	PTFE	PTFE	PTFE	
Flame arrester unit	A	A	B	

Special materials upon request

Table 6: Material combinations of the flame arrester unit

Design	A	B	* the FLAMEFILTER® are also available in the materials Tantalum, Inconel, Copper, etc. when the listed housing and cage materials are used.
FLAMEFILTER® *	Stainless Steel	Hastelloy	
Spacer	Stainless Steel	Hastelloy	

Special materials upon request

Table 7: Type of connection

Pipe thread DIN ISO 228-1	DIN	other types of thread upon request
---------------------------	-----	------------------------------------



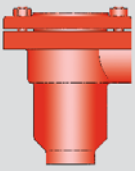

In-Line Detonation Flame Arrester

Flow Capacity Charts

PROTEGO® DR/ES

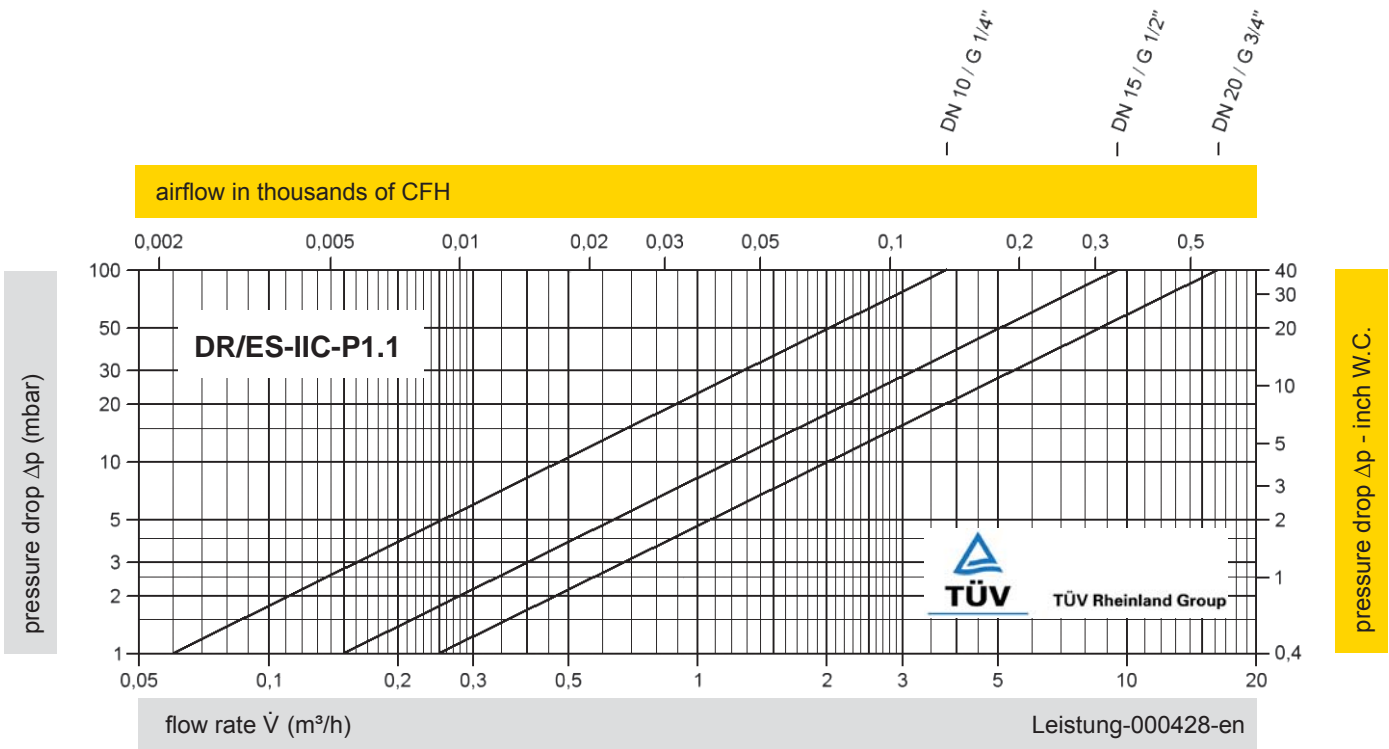
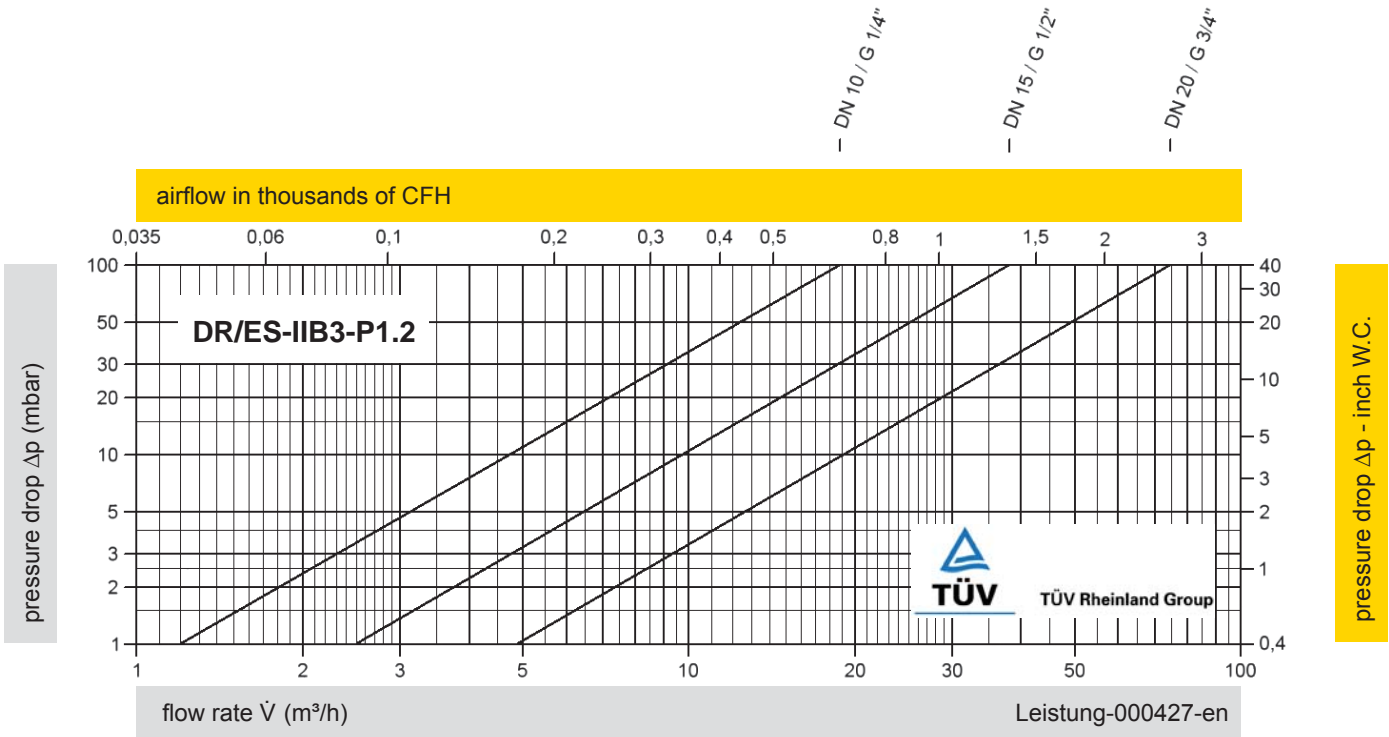

The flow capacity charts have been determined with a calibrated and TÜV certified flow capacity test rig.
 Volume flow \dot{V} in (m³/h) and CFH refer to the standard reference conditions of air ISO 6358 (20°C, 1bar). Conversion to other densities and temperatures refer to Vol. 1: "Technical Fundamentals".

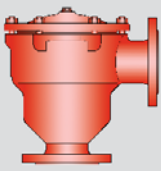

In-Line Detonation Flame Arrester

for stable detonations and deflagrations in right angle design with shock absorber, unidirectional

PROTEGO® DR/ES

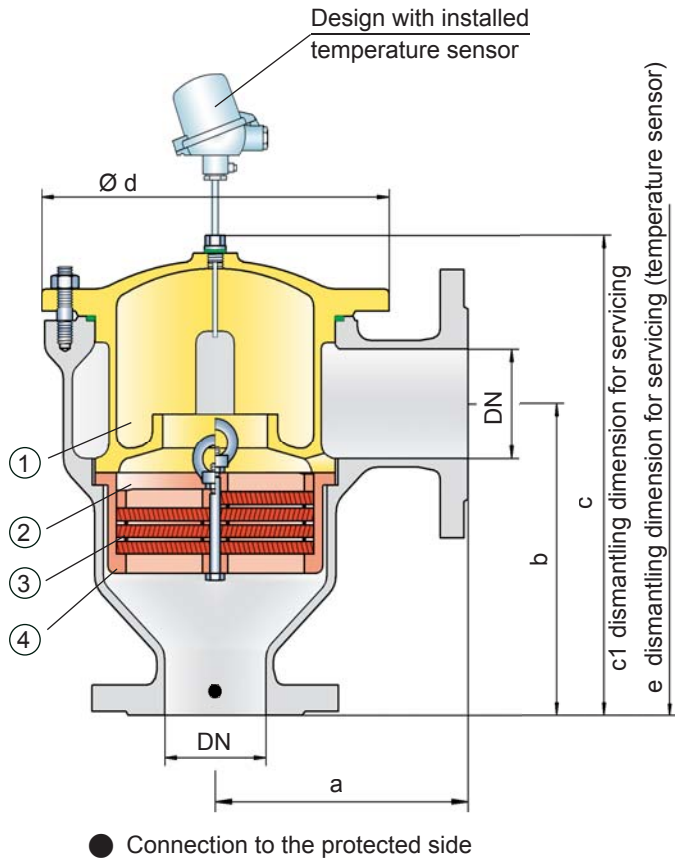

The standard design is approved at an operating temperature up to +60°C / 140°F and an absolute operating pressure up to 1.2bar/17.4psi. **Devices with special approvals can be obtained for higher pressures and higher temperatures upon request.**

Type-approved in accordance with the current ATEX Directive and EN ISO 16852 as well as other international standards.

Special Features and Advantages

- minimum number of FLAMEFILTER® discs due to the effective shock absorber
- quick removal and installation of the complete PROTEGO® flame arrester unit and FLAMEFILTER® discs in the cage
- due to modular design the FLAMEFILTER® discs can be individually replaced
- the right angle design saves pipe elbows
- extended application range for higher operating temperatures and pressures
- minimum pressure loss and hence low operating and life-cycle cost
- cost efficient spare parts

Design Types and Specifications

There are four different designs available:

Basic in-line detonation flame arrester **DR/ES-** -

In-line detonation flame arrester with integrated temperature sensor* as additional protection against short time burning **DR/ES-** **T** -

In-line detonation flame arrester with heating jacket **DR/ES-** **H** -

In-line detonation flame arrester with integrated temperature sensor* against short time burning and heating jacket **DR/ES-** **H** - **T**

*Resistance thermometer for device group II, category (1) 2 (GII cat. (1) 2)

Function and Description

The PROTEGO® DR/ES in-line detonation flame arrester has been used for decades in industrial plant construction because its right angle design offers advantages towards maintenance and costs in comparison to most straight designs.

Once a detonation enters the device, energy is absorbed from the detonation shock wave by the integrated shock absorber (1) before the flame is extinguished in the narrow gaps of the FLAMEFILTER® (3).

The PROTEGO® flame arrester unit (2) consists of several FLAMEFILTER® discs and spacers firmly held in the FLAMEFILTER® cage (4). The gap size and number of FLAMEFILTER® discs are determined by the operating data of the mixture flowing in the line (explosion group, pressure, temperature). This device is approved for explosion groups from IIA to IIB3 (NEC group D to C MESH ≥ 0.65 mm).



Table 1: Dimensions

Dimensions in mm / inches

To select the nominal size (DN), please use the flow capacity charts on the following pages

DN	25 / 1"	32 / 1 ¼"	40 / 1 ½"	50 / 2"	65 / 2 ½"	80 / 3"	100 / 4"	125 / 5"	150 / 6"	200 / 8"
a	125/4.92	125/4.92	153/6.02	155/6.10	198/7.80	200/7.87	250/9.84	332/13.07	335/13.19	425/16.73
b	140/5.51	140/5.51	183/7.20	185/7.28	223/8.78	225/8.86	290/11.42	357/14.06	360/14.07	505/19.88
c	210/8.27	210/8.27	290/11.42	290/11.42	365/14.37	365/14.37	440/17.32	535/21.06	535/21.06	810/31.89
c1	285/11.22	285/11.22	395/15.55	395/15.55	500/19.69	500/19.69	595/23.43	750/29.53	750/29.53	1230/48.43
d	150/5.91	150/5.91	210/8.27	210/8.27	275/10.83	275/10.83	325/12.80	460/18.11	460/18.11	620/24.41
e	495/19.49	495/19.49	600/23.62	600/23.62	705/27.76	705/27.76	795/31.30	950/37.40	950/37.40	1435/56.50

Table 2: Selection of the explosion group

MESG	Expl. Gr. (IEC/CEN)	Gas Group (NEC)	
> 0,90 mm	IIA	D	Special approvals upon request
≥ 0,65 mm	IIB3	C	

Table 3: Selection of max. operating pressure

		DN	25 / 1"	32 / 1 ¼"	40 / 1 ½"	50 / 2"	65 / 2 ½"	80 / 3"	100 / 4"	125 / 5"	150 / 6"	200 / 8"
Expl. Gr.	IIA	P _{max}	4.0/58.0	4.0/58.0	4.0/58.0	4.0/58.0	2.9/42.1	2.9/42.1	2.0/29.0	2.0/29.0	2.0/29.0	1.2/17.4
	IIB3	P _{max}	3.0/43.5	3.0/43.5	2.0/29.0	2.0/29.0	2.0/29.0	2.0/29.0	1.5/21.7	1.4/20.3	1.4/20.3	1.1/15.9

P_{max} = maximum allowable operating pressure in bar / psi (absolute), higher operating pressure upon request

Table 4: Specification of max. operating temperature

≤ 60°C / 140°F	T _{maximum allowable operating temperature in °C}	
-	Designation	higher operating temperatures upon request

Table 5: Material selection for housing

Design	B	C	D	
Housing	Steel	Stainless Steel	Hastelloy	* for devices exposed to elevated temperatures above 150°C / 302°F, gaskets made of PTFE. The housing and cover with the shock absorber can also be delivered in steel with an ECTFE coating.
Heating jacket (DR/ES-H-(T)-...)	Steel	Stainless Steel	Stainless Steel	
Cover with shock absorber	Steel	Stainless Steel	Hastelloy	
O-Ring	FPM*	PTFE	PTFE	
Flame arrester unit	A	C, D	E	Special materials upon request

Table 6: Material combinations of the flame arrester unit

Design	A	C	D	E	
FLAMEFILTER® cage	Steel	Stainless Steel	Stainless Steel	Hastelloy	* the FLAMEFILTER® are also available in the materials Tantalum, Inconel, Copper, etc. when the listed housing and cage materials are used.
FLAMEFILTER® *	Stainless Steel	Stainless Steel	Hastelloy	Hastelloy	
Spacer	Stainless Steel	Stainless Steel	Hastelloy	Hastelloy	

Special materials upon request

Table 7: Flange connection type

EN 1092-1; Form B1	other types upon request
ASME B16.5; 150 lbs RFSF	



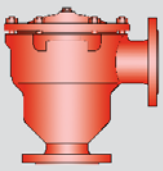

In-Line Detonation Flame Arrester

Flow Capacity Charts

PROTEGO® DR/ES

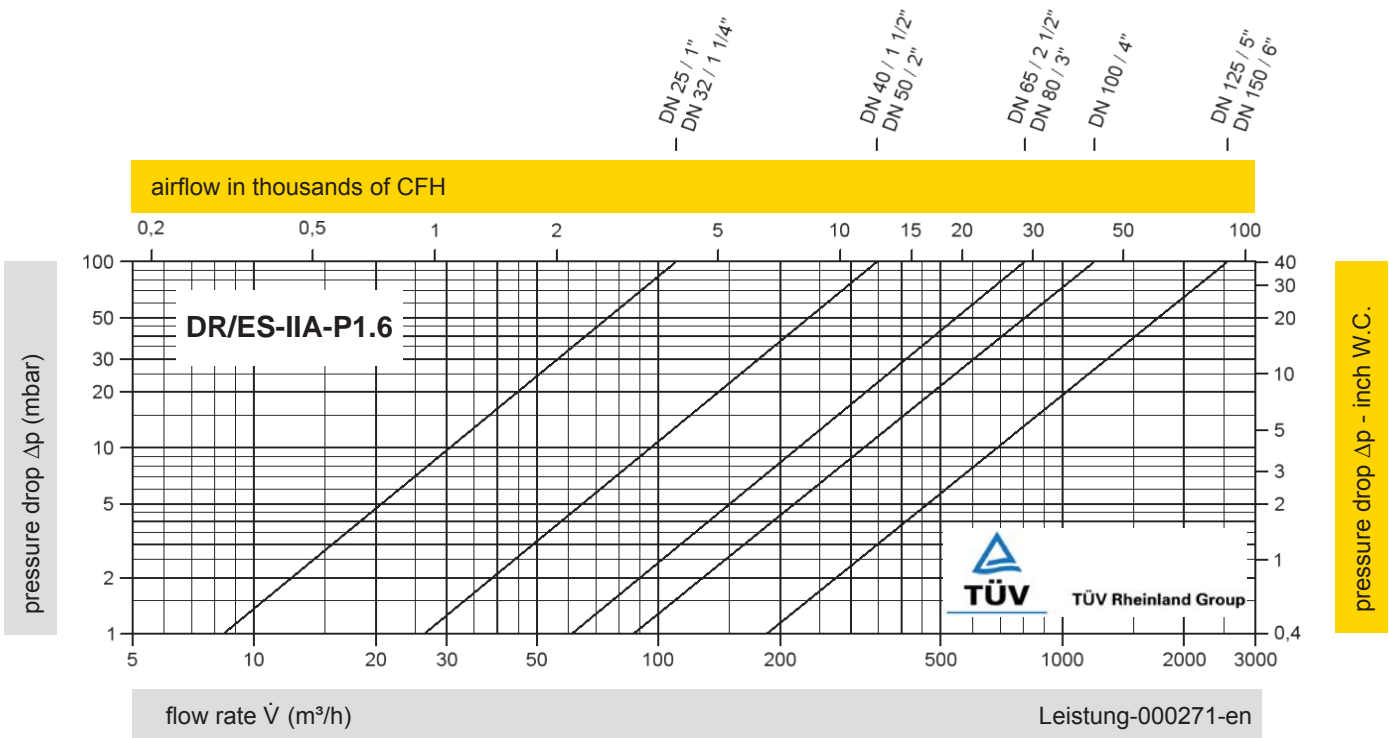
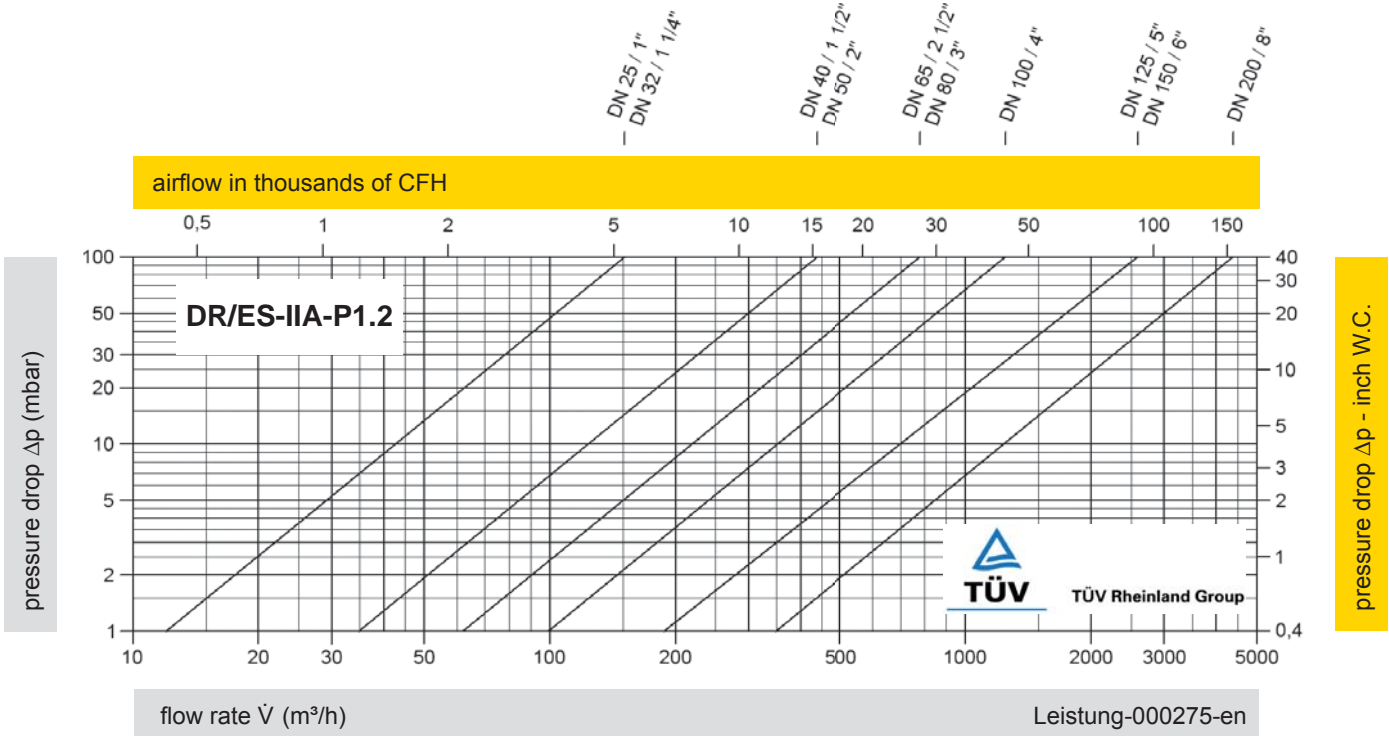

The flow capacity charts have been determined with a calibrated and TÜV certified flow capacity test rig.

Volume flow \dot{V} in (m³/h) and CFH refer to the standard reference conditions of air ISO 6358 (20°C, 1bar). Conversion to other densities and temperatures refer to Vol. 1: "Technical Fundamentals".

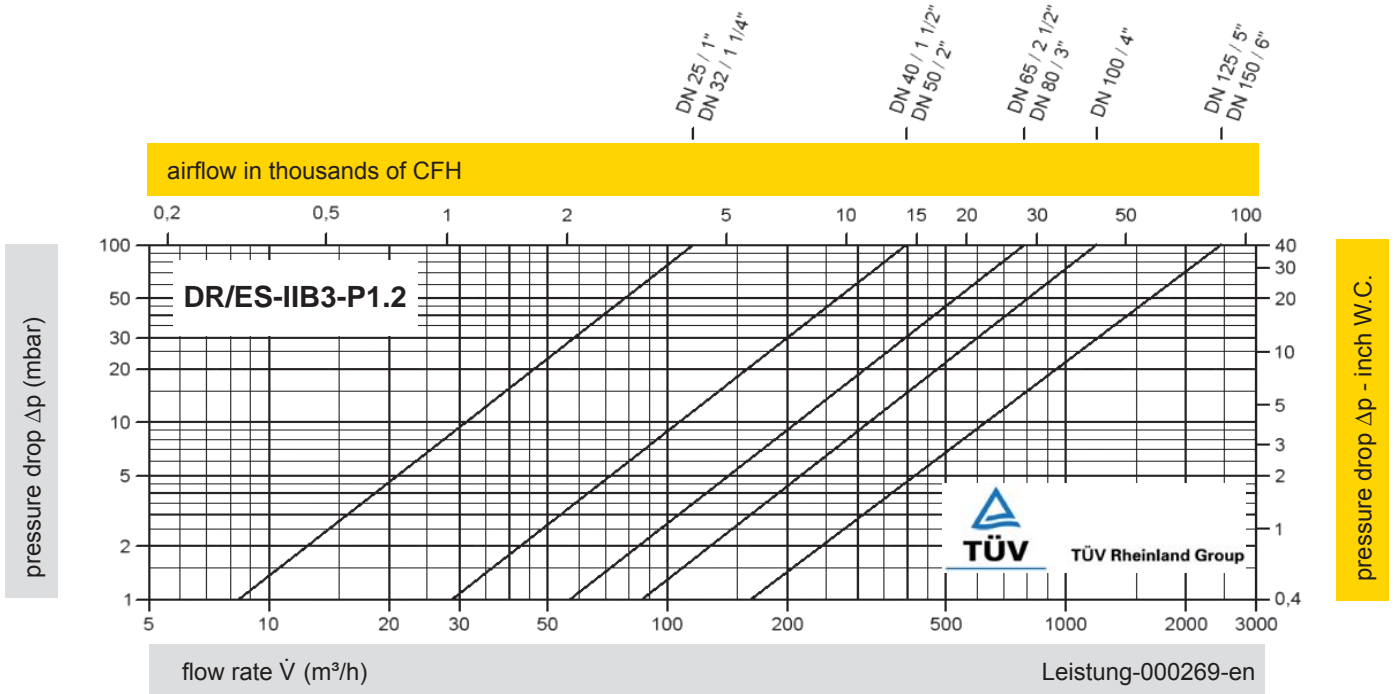

* DN 25 - DN 80; P1.6
 DN 100; P1.5
 DN 125, DN 150; P1.4
 DN 200; P1.1

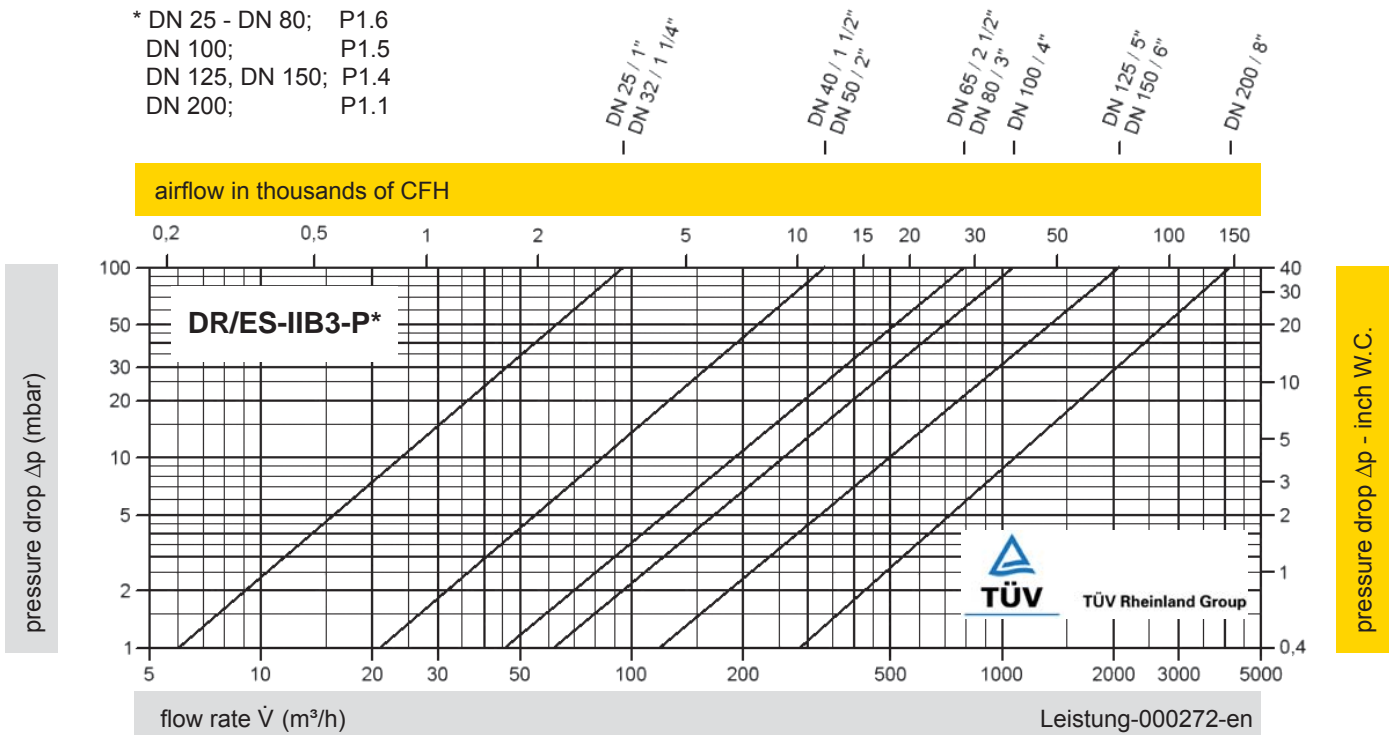

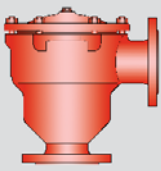

In-Line Detonation Flame Arrester

Flow Capacity Charts (liquid)

PROTEGO® DR/ES

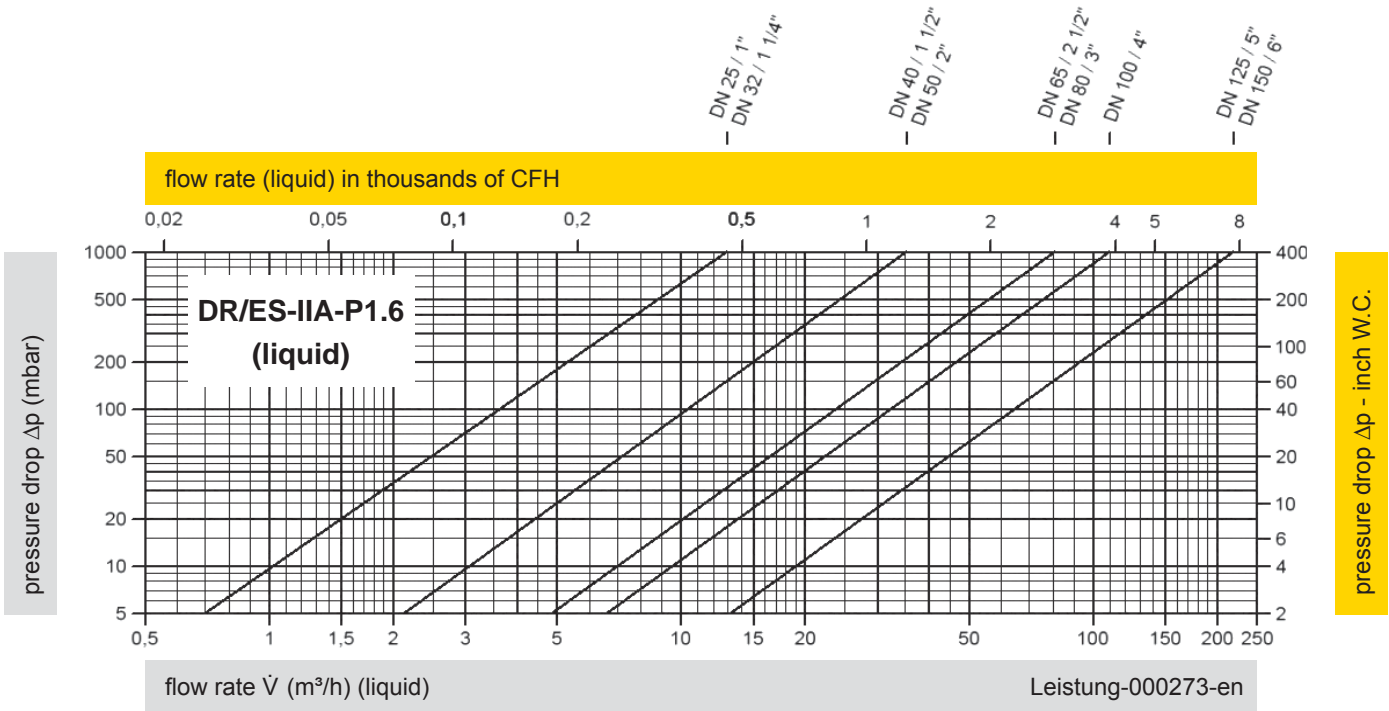

- * DN 25 - DN 80; P1.6
- DN 100; P1.5
- DN 125, DN 150; P1.4
- DN 200; P1.1

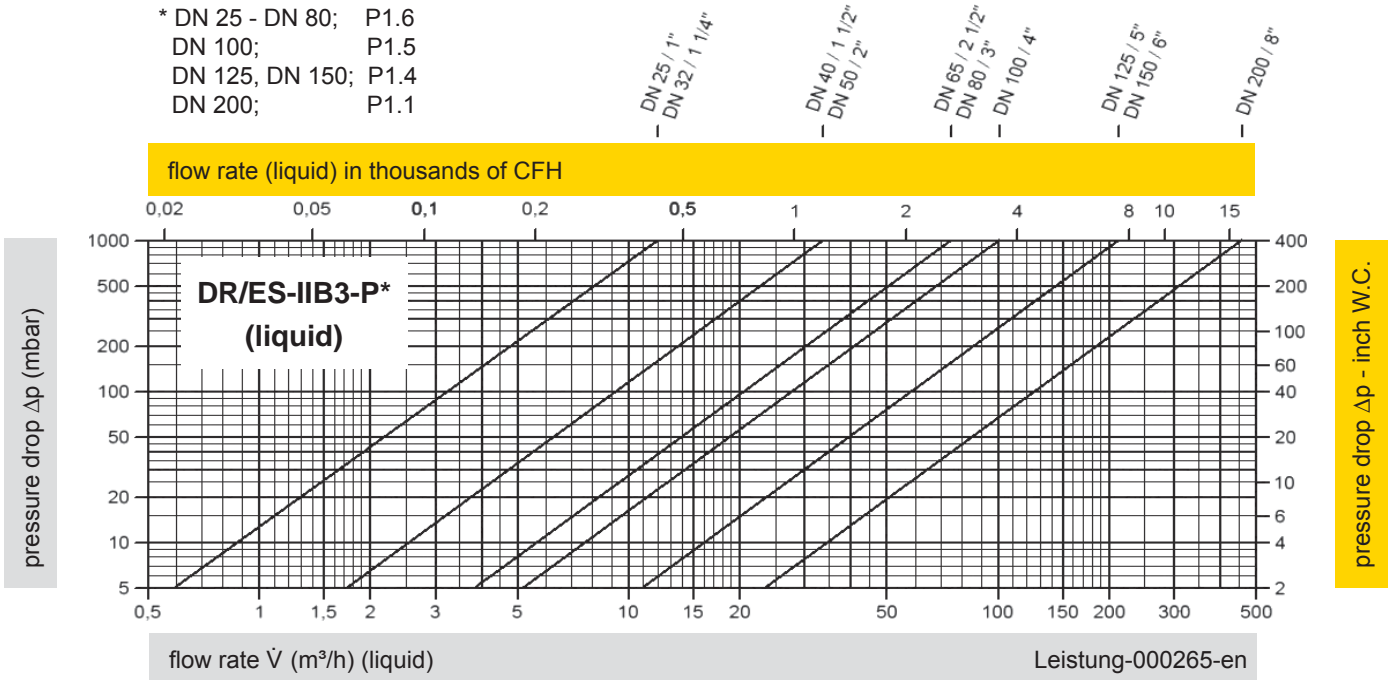

$$\text{Conversion: } \dot{V}_{\text{liquid}} = \dot{V}_{\text{water}} * \sqrt{\frac{\rho_{\text{water}}}{\rho_{\text{liquid}}}}$$

The volume flow \dot{V} in m³/h was determined with water according to DIN EN 60534 at a temperature $T_n = 15^\circ\text{C}$ and an atmospheric pressure $p_n = 1,013 \text{ bar}$, kinematic viscosity $\nu = 10^{-6} \text{ m}^2/\text{s}$

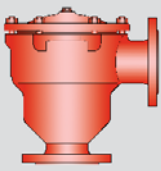

In-Line Detonation Flame Arrester

with integrated pressure relief valve, for stable detonations and deflagrations in right angle design with shock absorber, unidirectional

PROTEGO® DR/ES-V

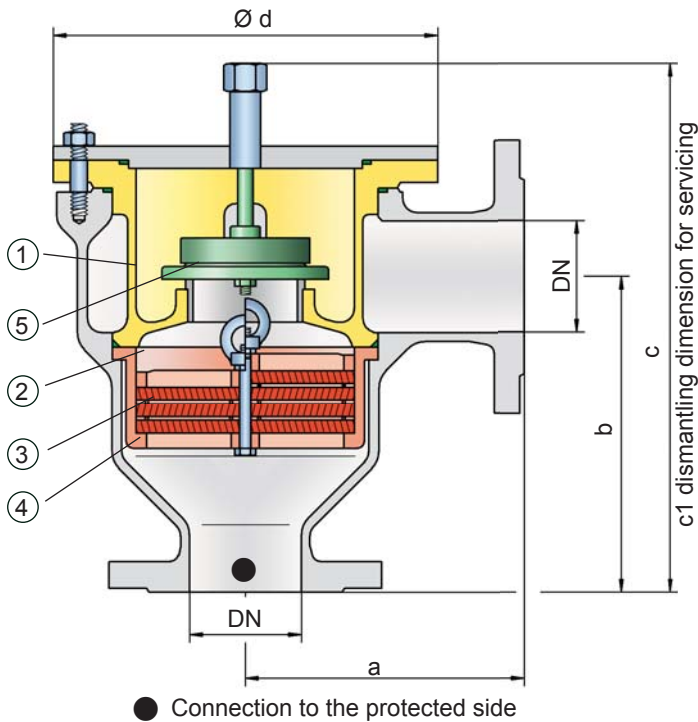

Set pressure: from +2.0 mbar up to +35 mbar
from +0.8 inch W.C. up to +14 inch W.C.

Higher or lower settings upon request

Function and Description

PROTEGO® DR/ES-V series uniquely combines the function of a in-line detonation flame arrester with the function of a pressure relief valve in one device. The device protects against deflagration and stable detonation. The weight-loaded pallet type valve (5) integrated in the shock absorber (1) of the in-line detonation flame arrester is designed as pressure relief valve. The set pressure of the valve is adjusted in the factory and can range from 2 to 35 mbar (0.8 to 14 inch W.C.). After the pressure increases 40% from its set pressure, the valve completely opens to yield the maximum volumetric flow. If installed in vent headers connected to storage tanks, the valve pallet works as check valve. This means that the product can not flow back from the suction line into the tank. Although several functions are integrated in a single housing, the device is extremely easy to service, which is primarily due to the classic right angle design.

Once a detonation enters the flame arrester, energy is absorbed from the detonation shock wave by the integrated shock

absorber, before the flame is extinguished in the narrow gaps of the FLAMEFILTER® (3). The flame suppression is guaranteed independent of the valve pallet position.

The PROTEGO® flame arrester unit (2) consists of several FLAMEFILTER® discs and spacers firmly held in the FLAMEFILTER® cage (4). The gap size and number of FLAMEFILTER® discs are determined by the operating data parameters of the mixture flowing in the line (explosion group, pressure, temperature). This device is available for explosion groups from IIA to IIB3 (NEC group D to C MESH ≥ 0.65 mm).

The standard design is approved at an operating temperature up to +60°C / 140°F and absolute operating pressure up to 1.2bar/17.4psi. **Devices with special approvals can be obtained for higher pressures and higher temperatures upon request.**

Type-approved in accordance with the current ATEX Directive and EN ISO 16852 as well as other international standards.

Special Features and Advantages

- integration of in-line detonation flame arrester and pressure relief valve in one device
- excellent tightness of the valve
- applicable as a detonation-proof check valve in suction lines of storage tanks
- optimum for use as an overflow valve in venting and recovering vapour lines
- minimum number of FLAMEFILTER® discs due to the effective shock absorber
- quick removal and installation of the complete PROTEGO® flame arrester unit and the individual FLAMEFILTER® discs in the cage
- provides protection from deflagration and stable detonations
- extended application range for higher operating temperatures and pressures
- cost efficient spare parts

Design Types and Specifications

There are two different designs available:

Basic version of the detonation arrester with check valve **DR/ES--**

Detonation arrester with check valve and heating jacket **DR/ES--**

Table 1: Dimensions

Dimensions in mm / inches

To select the nominal size (DN), please use the flow capacity charts on the following pages

DN	25 / 1 / 32 / 1 1/4"	40 / 1 1/2"	50 / 2"	65 / 2 1/2"	80 / 3"	100 / 4"	125 / 5"	150 / 6"	200 / 8"
a	125 / 4.92	153 / 6.02	155 / 6.10	198 / 7.80	200 / 7.87	250 / 9.84	332 / 13.07	335 / 13.19	425 / 16.73
b	140 / 5.51	183 / 7.20	185 / 7.28	223 / 8.78	225 / 8.86	290 / 11.42	357 / 14.06	360 / 14.17	505 / 19.88
c	237 / 9.33	305 / 12.01	305 / 12.01	395 / 15.55	395 / 15.55	460 / 18.11	575 / 22.64	575 / 22.64	863 / 33.98
c1	345 / 13.58	410 / 16.14	410 / 16.14	530 / 20.87	530 / 20.87	615 / 24.21	790 / 31.10	790 / 31.10	1295 / 50.98
d	149 / 5.87	210 / 8.27	210 / 8.27	275 / 10.83	275 / 10.83	325 / 12.80	460 / 18.11	460 / 18.11	620 / 24.41



Table 2: Selection of the explosion group

MESG	Expl. Gr. (IEC/CEN)	Gas Group (NEC)	Special approvals upon request
> 0,90 mm	IIA	D	
≥ 0,65 mm	IIB3	C	

Table 3: Selection of max. operating pressure

Expl. Gr.	DN	25 / 1	32 / 1 ¼"	40 / 1 ½"	50 / 2"	65 / 2 ½"	80 / 3"	100 / 4"	125 / 5"	150 / 6"	200 / 8"
IIA	P _{max}	4.0/58.0	4.0/58.0	4.0/58.0	4.0/58.0	2.9/42.1	2.9/42.1	2.0/29.0	2.0/29.0	2.0/29.0	1.2/17.4
IIB3	P _{max}	3.0/43.5	3.0/43.5	2.0/29.0	2.0/29.0	2.0/29.0	2.0/29.0	1.5/21.7	1.4/20.3	1.4/20.3	1.1/15.9

P_{max} = maximum allowable operating pressure in bar / psi (absolute), higher operating pressure upon request

Table 4: Specification of max. operating temperature

≤ 60°C / 140°F	T _{maximum allowable operating temperature in °C}	higher operating temperatures upon request
-	Designation	

Table 5: Material selection for housing

Design	B	C	D	The housing and the cover with shock absorber can also be delivered in steel with an ECTFE coating.
Design	Steel	Stainless Steel	Hastelloy	
Heating jacket (DR/ES-V-H-...)	Steel	Stainless Steel	Stainless Steel	
Cover with shock absorber	Steel	Stainless Steel	Hastelloy	
Gaskets	PTFE	PTFE	PTFE	
Valve seat	Stainless Steel	Stainless Steel	Stainless Steel	
Flame arrester unit	A	C, D	E	

Special materials upon request

Table 6: Material combinations of the flame arrester unit

Design	A	C	D	E	* the FLAMEFILTER® are also available in the materials Tantalum, Inconel, Copper, etc. when the listed housing and cage materials are used.
FLAMEFILTER® cage	Steel	Stainless Steel	Stainless Steel	Hastelloy	
FLAMEFILTER® *	Stainless Steel	Stainless Steel	Hastelloy	Hastelloy	
Spacer	Stainless Steel	Stainless Steel	Hastelloy	Hastelloy	

Special materials upon request

Table 7: Material selection for valve pallet

Design	A	B	C
Pressure range	I	II	III
Set pressure (mbar) [inch W.C.]	+2.0 up to +3.5 +0.8 up to +1.4	>+3.5 up to +14 >+1.4 up to +5.6	>+14 up to 35 >+5.6 up to 14
Valve pallet	Aluminium	Stainless Steel	Stainless Steel
Sealing	FEP	FEP	Metal to Metal

Table 8: Flange connection type

EN 1092-1; Form B1	other types upon request
ASME B16.5; 150 lbs RFSF	



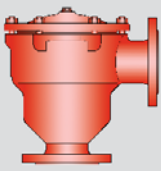

In-Line Detonation Flame Arrester

Flow Capacity Charts

PROTEGO® DR/ES-V

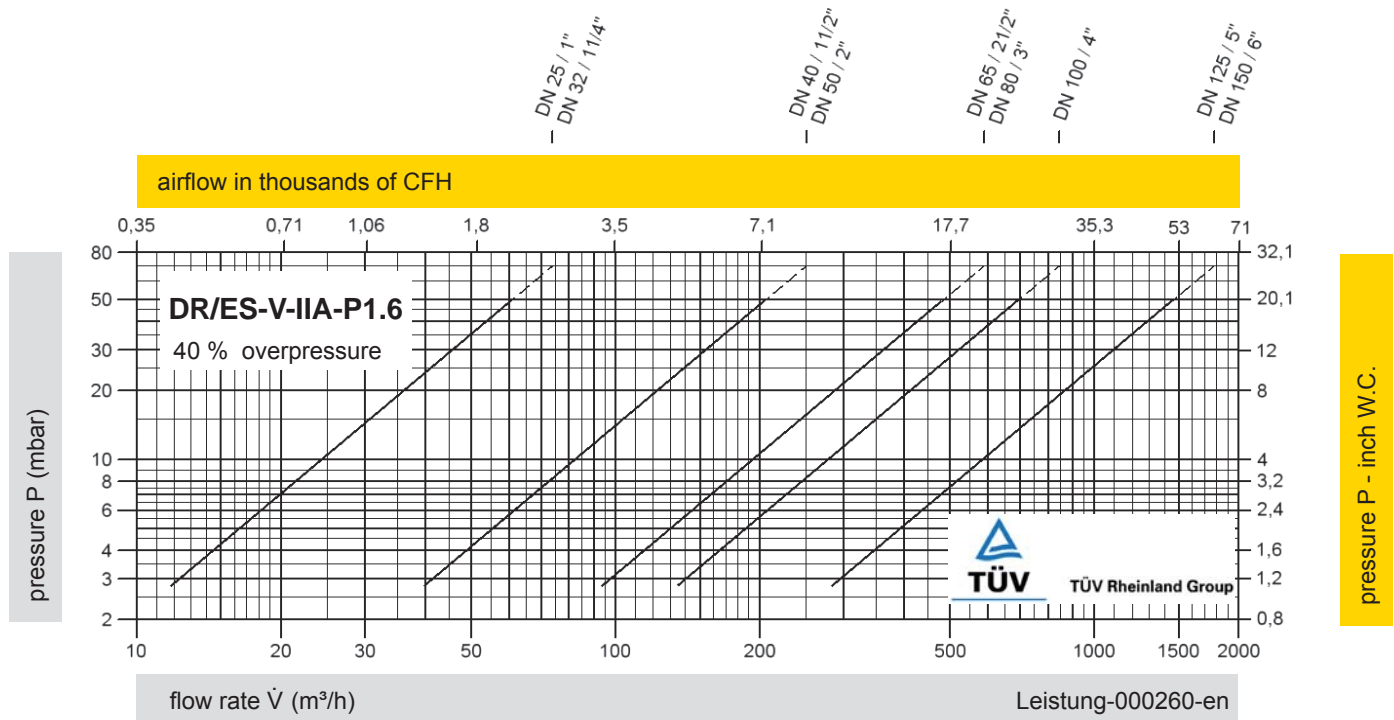
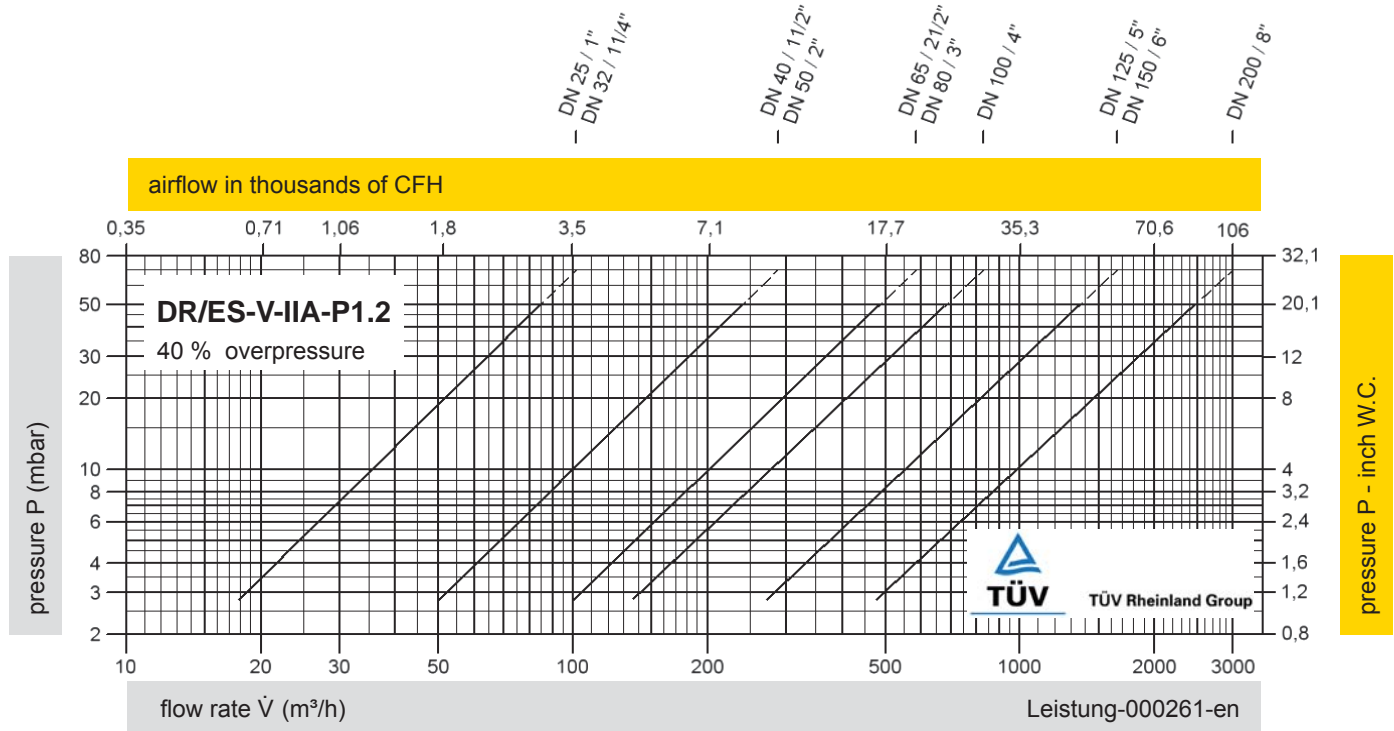

Remark

$$\text{set pressure} = \frac{\text{opening pressure resp. tank design pressure}}{1,4}$$

Set pressure = the valve starts to open

Opening pressure = set pressure plus overpressure

Overpressure = pressure increase over the set pressure

The flow capacity charts have been determined with a calibrated and TÜV certified flow capacity test rig.

Volume flow \dot{V} in (m³/h) and CFH refer to the standard reference conditions of air ISO 6358 (20°C, 1bar).

Conversion to other densities and temperatures refer to Vol. 1: "Technical Fundamentals".

PROTEGO® DR/ES-V

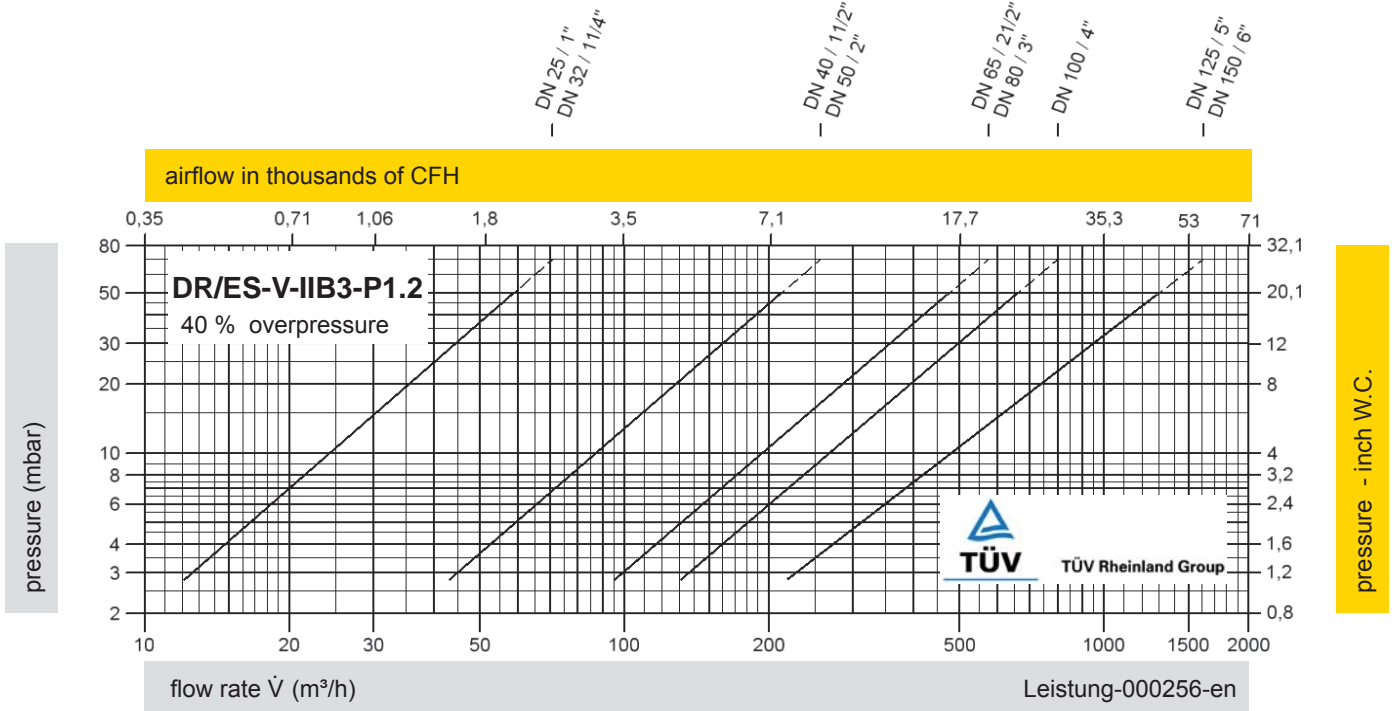

* DN 25 - DN 80; P1.6
DN 100; P1.5
DN 125, DN 150; P1.4
DN 200; P1.1

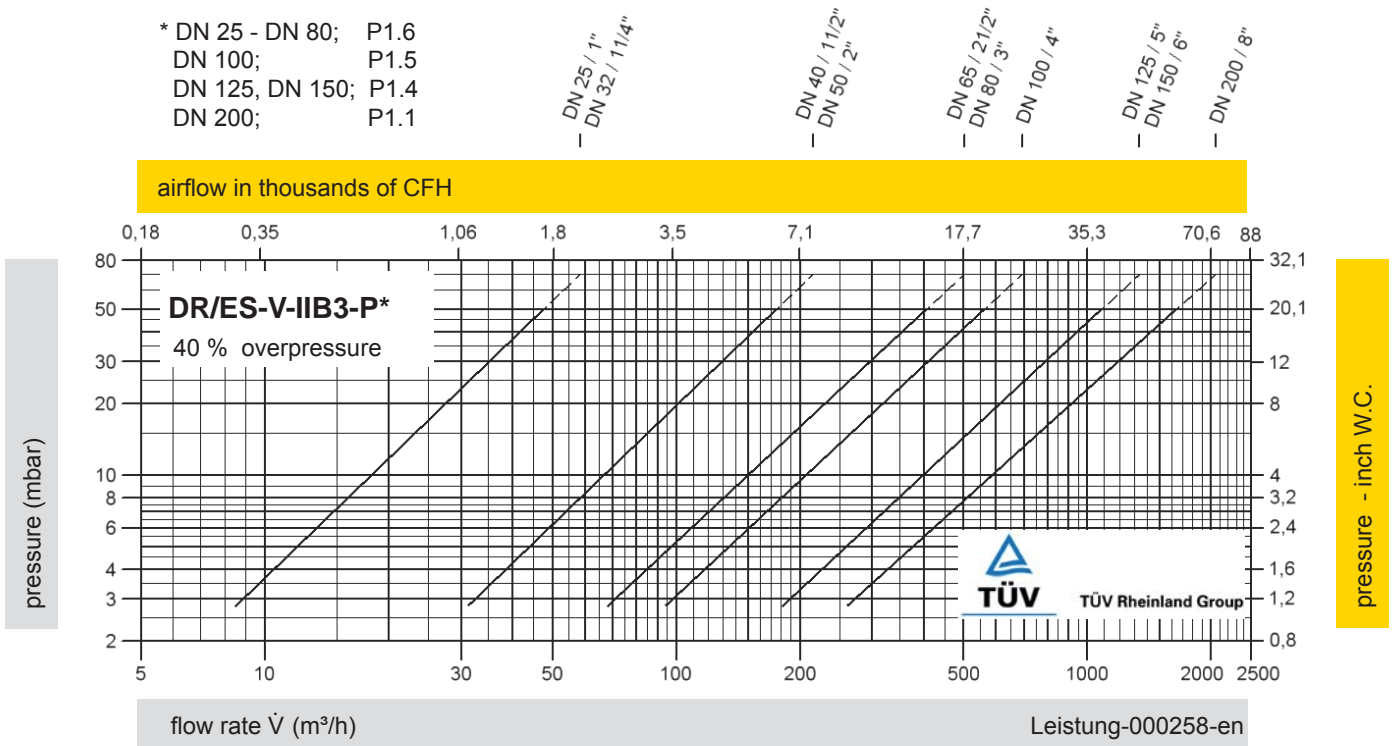



In-Line Liquid Detonation Flame Arrester

for filling lines - external installation

PROTEGO® LDA-W

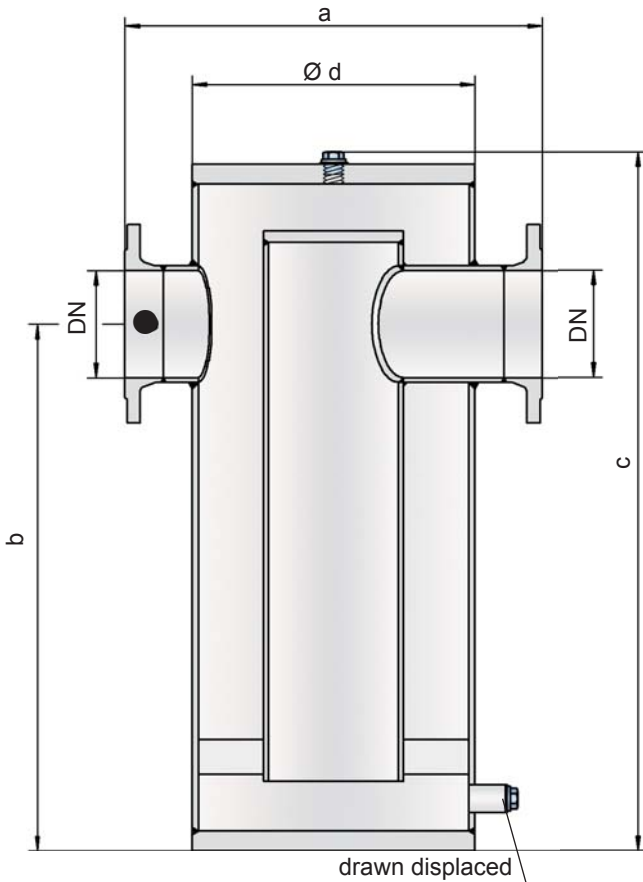

● Tank connection / protected side

When a highly accelerated pipe deflagration or detonation occurs, the combustion pressure and flame propagation speed is first substantially reduced by the construction and converted into a low-energy deflagration that is then stopped by the remaining immersion liquid.

The application range for the device is a product vapour/ air mixture temperature up to +60°C / 140°F and an absolute pressure up to 1.1 bar / 15.9 psi. This covers all of the possible operating conditions of empty lines for flammable liquids. The liquid detonation arrester is designed for pressures up to 10 bar / 145 psi and therefore resists explosion pressure offering protection for almost all flammable liquids. The device is approved for explosion groups IIA to IIB3 (NEC group D to C MESH ≥ 0.65 mm). **Special designs with a cleaning cover for highly viscous and contaminated liquids can be provided.**

Type-approved in accordance with the current ATEX Directive and EN ISO 16852 as well as other international standards.

Special Features and Advantages

- the device is easily accessible since it is mounted on the containers outside
- minimum risk of soiling
- low pressure loss
- provides protection from deflagrations and stable detonations
- useful for nearly all flammable liquids
- meets TRbF* requirements
- maintenance friendly design also useable as strainer

*TRbF = technical regulations for flammable liquids

Function and Description

The PROTEGO® LDA-W liquid detonation flame arrester was developed for storage container filling lines that are not continuously filled with product and sometimes contain a combustible mixture. The device is installed outside of the container in the filling line. If the explosive atmosphere is ignited, the device prevents the combustion from traveling into the tank. The PROTEGO® LDA-W series of liquid detonation flame arresters functions according to the siphon principle in which the liquid product serves as a barrier against flame propagation.

Table 1: Dimensions

Dimensions in mm / inches

To select the nominal size (DN), please use the flow capacity chart on the following pages

DN	25 1"	32 1 ¼"	40 1 ½"	50 2"	65 2 ½"	80 3"	100 4"	125 5"	150 6"	200 8"	250 10"	300 12"
a	250 / 9.84	275 / 10.83	350 / 13.78	350 / 13.78	450 / 17.72	450 / 17.72	500 / 19.69	600 / 23.62	600 / 23.62	700 / 27.56	850 / 33.46	1000 / 39.37
b	325 / 12.80	360 / 14.17	420 / 16.54	420 / 16.54	540 / 21.26	540 / 21.26	595 / 23.43	915 / 36.02	915 / 36.02	1100 / 43.31	1325 / 52.17	1480 / 58.27
c	445 / 17.52	480 / 18.90	565 / 22.24	565 / 22.24	720 / 28.35	720 / 28.35	800 / 31.50	1265 / 49.80	1265 / 49.80	1520 / 59.84	1830 / 72.05	2050 / 80.71
d	140 / 5.51	140 / 5.51	195 / 7.68	195 / 7.68	275 / 10.83	275 / 10.83	325 / 12.80	460 / 18.11	460 / 18.11	510 / 20.08	610 / 24.02	700 / 27.56

Table 2: Selection of the explosion group

MESG	Expl. Gr. (IEC/CEN)	Gas Group (NEC)	
> 0,90 mm	IIA	D	Special approvals upon request
≥ 0,65 mm	IIB3	C	

Table 3: Specification of max. operating temperature

≤ 60°C / 140°F	Tmaximum allowable operating temperature in °C	higher operating temperatures upon request
-	Designation	

Table 4: Material selection for housing

Design	A	B	C	
Housing	Steel	Stainless Steel	Hastelloy	Special materials upon request
Gasket	PTFE	PTFE	PTFE	

Table 5: Flange connection type

EN 1092-1; Form B1	other types upon request
ASME B16.5; 150 lbs RF5F	

Flow Capacity Chart

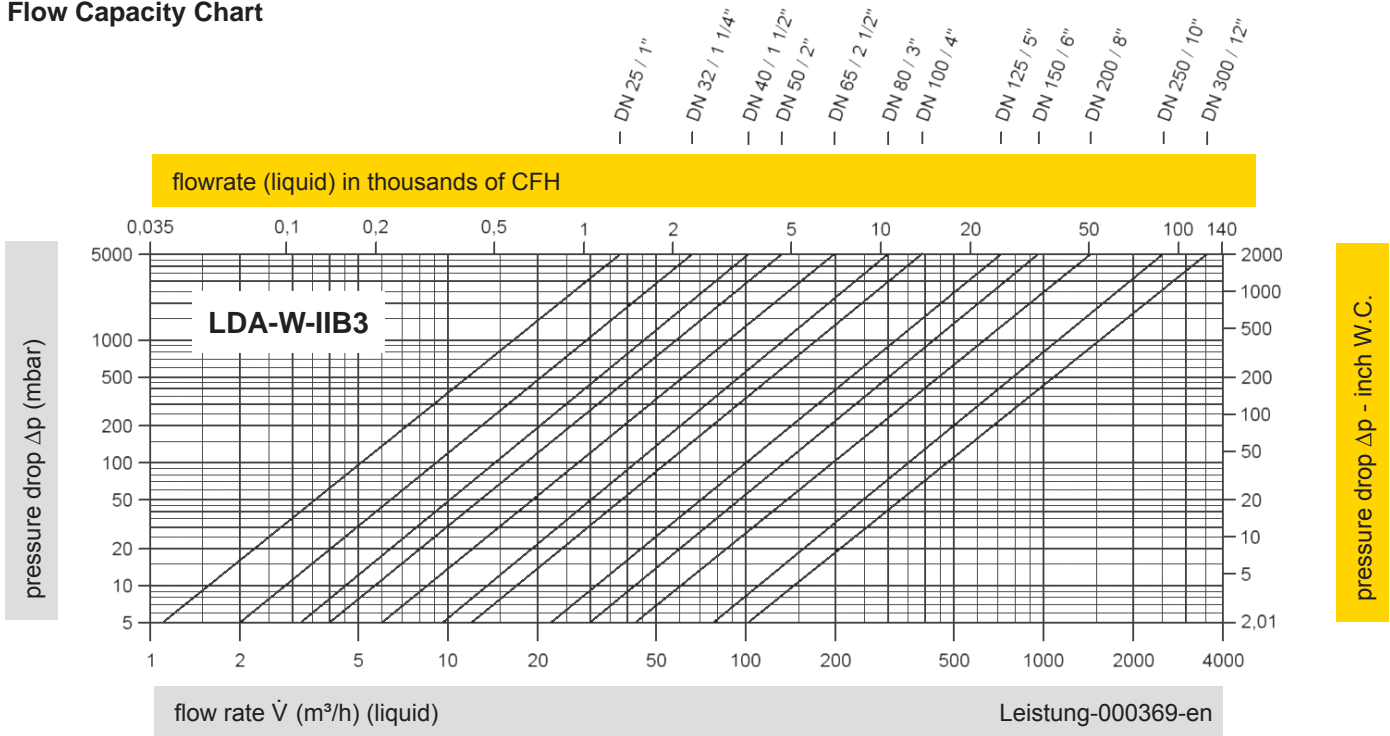

Conversion: $V_{liquid}^j = V_{water}^j * \sqrt{\frac{\rho_{water}}{\rho_{liquid}}}$

The volume flow \dot{V} in m³/h was determined with water according to DIN EN 60534 at a temperature $T_n = 15^\circ\text{C}$ and an atmospheric pressure $p_n = 1,013 \text{ bar}$, kinematic viscosity $\nu = 10^{-6} \text{ m}^2/\text{s}$.

To avoid electrostatic charge of flammable liquids the maximum flow is limited (refer to BG-Regulation 132, CENELEC-Report CLC/TR 50404).



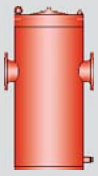

In-Line Liquid Detonation Flame Arrester

for filling and drain lines - external installation



PROTEGO® LDA-WF(W)

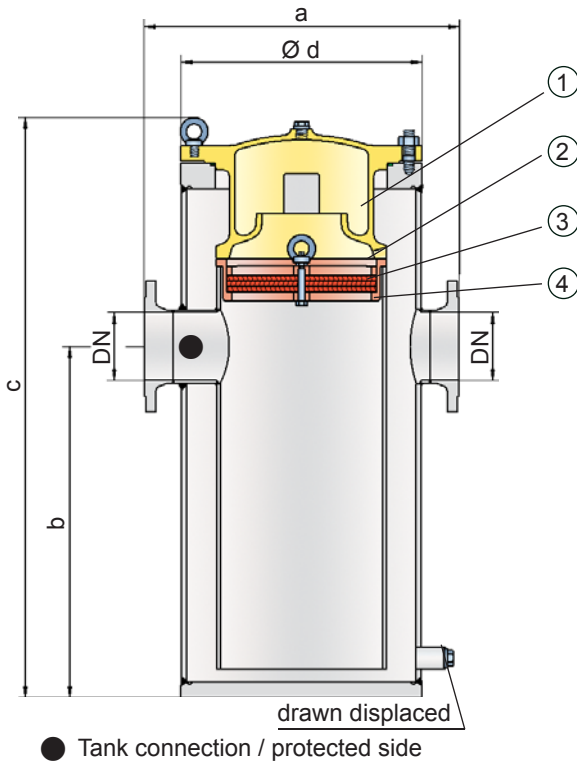

sphere is ignited, the device prevents the combustion from traveling into the tank. The PROTEGO® LDA-WF(W) series of liquid detonation flame arresters combines the classic PROTEGO® flame arrester design with the siphon principle in which the liquid product serves as a barrier to flame propagation.

When a highly accelerated pipe deflagration or detonation occurs, the combustion pressure and flame propagation speed is first substantially reduced by the design and converted into a low-energy deflagration that is then stopped by the remaining immersion liquid and the PROTEGO® flame arrester.

The application range for the device is a product vapour/air mixture temperature up to +60°C / 140°F and an absolute pressure up to 1.1 bar / 15.9 psi. **Devices with special approval can be obtained for higher temperatures upon request.** This covers all of the possible operating conditions of empty lines for flammable liquids. The liquid detonation arrester is designed for pressures up to 10 bar / 145 psi and therefore resists explosion pressure and offers protection for almost all flammable liquids. The device is approved for explosion groups IIA to IIB3 (NEC group D to C MESH ≥ 0.65 mm). **Special designs with a cleaning cover for highly viscous liquids can be provided.**

Type-approved in accordance with the current ATEX Directive and EN ISO 16852 as well as other international standards.

Function and Description

The PROTEGO® LDA-WF(W) series of liquid detonation flame arresters was developed for storage container filling lines that are not continuously filled with product and sometimes contain a combustible mixture. The integrated siphon protection (1) with PROTEGO® flame arrester unit (2) additionally prevents the liquid in which the lines are immersed from being siphoned off while the container is being drained. PROTEGO® flame arrester consists of several FLAMEFILTER® discs (3) and spacers firmly held in a FLAMEFILTER® cage (4). The number of FLAMEFILTER® discs and their gap size depends on the arresters conditions of use. The device is installed outside of the container in the filling and drain lines. If the explosive atmo-

Special Features and Advantages

- the device is easily accessible since it is mounted on the containers outside
- siphon protection offers a high degree of safety
- minimum risk of soiling
- low pressure loss
- provides protection from deflagrations and stable detonations
- useful for nearly all flammable liquids
- meets TRbF* requirements

*TRbF = technical regulations for flammable liquids

Table 1: Dimensions

Dimensions in mm / inches

To select the nominal size (DN), please use the flow capacity chart on the following pages

DN	25 1"	32 1 1/4"	40 1 1/2"	50 2"	65 2 1/2"	80 3"	100 4"	125 5"	150 6"	200 8"	250 10"
a	250 / 9.84	250 / 9.84	346 / 13.62	350 / 13.78	446 / 17.56	450 / 17.72	500 / 19.69	600 / 23.62	600 / 23.62	700 / 27.56	900 / 35.43
b	325 / 12.80	325 / 12.80	415 / 16.34	415 / 16.34	535 / 21.06	535 / 21.06	600 / 23.62	915 / 36.02	915 / 36.02	1090 / 42.91	1300 / 51.18
c	475 / 18.70	475 / 18.70	605 / 23.82	605 / 23.82	831 / 32.72	831 / 32.72	936 / 36.58	1340 / 52.76	1340 / 52.76	1520 / 59.84	1750 / 68.90
d	150 / 5.91	150 / 5.91	210 / 8.27	210 / 8.27	275 / 10.83	275 / 10.83	325 / 12.80	460 / 18.11	460 / 18.11	510 / 20.08	610 / 24.02

Table 2: Selection of the explosion group

MESH	Expl. Gr. (IEC/CEN)	Gas Group (NEC)	Special approvals upon request
> 0,90 mm	IIA	D	
$\geq 0,65$ mm	IIB3	C	



Stabilized FLAMEFILTER®
Discs (Flyer pdf)

Table 3: Specification of max. operating temperature

≤ 60°C / 140°F	Tmaximum allowable operating temperature in °C	higher operating temperatures upon request
-	Designation	

Table 4: Material selection for housing

Design	A	B	Special materials upon request
Housing	Steel	Stainless Steel	
Shock absorber	Steel	Stainless Steel	
Gasket (shock absorber)	FPM	PTFE	
Gasket (locking screw)	PTFE	PTFE	
Flame arrester unit	A	A	

Table 5: Material for flame arrester unit

Design	A	* the FLAMEFILTER® are also available in the materials Tantalum, Inconel, Copper, etc. when the listed housing and cage materials are used.
FLAMEFILTER® cage	Stainless Steel	
FLAMEFILTER® *	Stainless Steel	Special materials upon request.
Spacer	Stainless Steel	

Table 6: Flange connection type

EN 1092-1; Form B1	other types upon request
ASME B16.5; 150 lbs RF5F	

Flow Capacity Chart

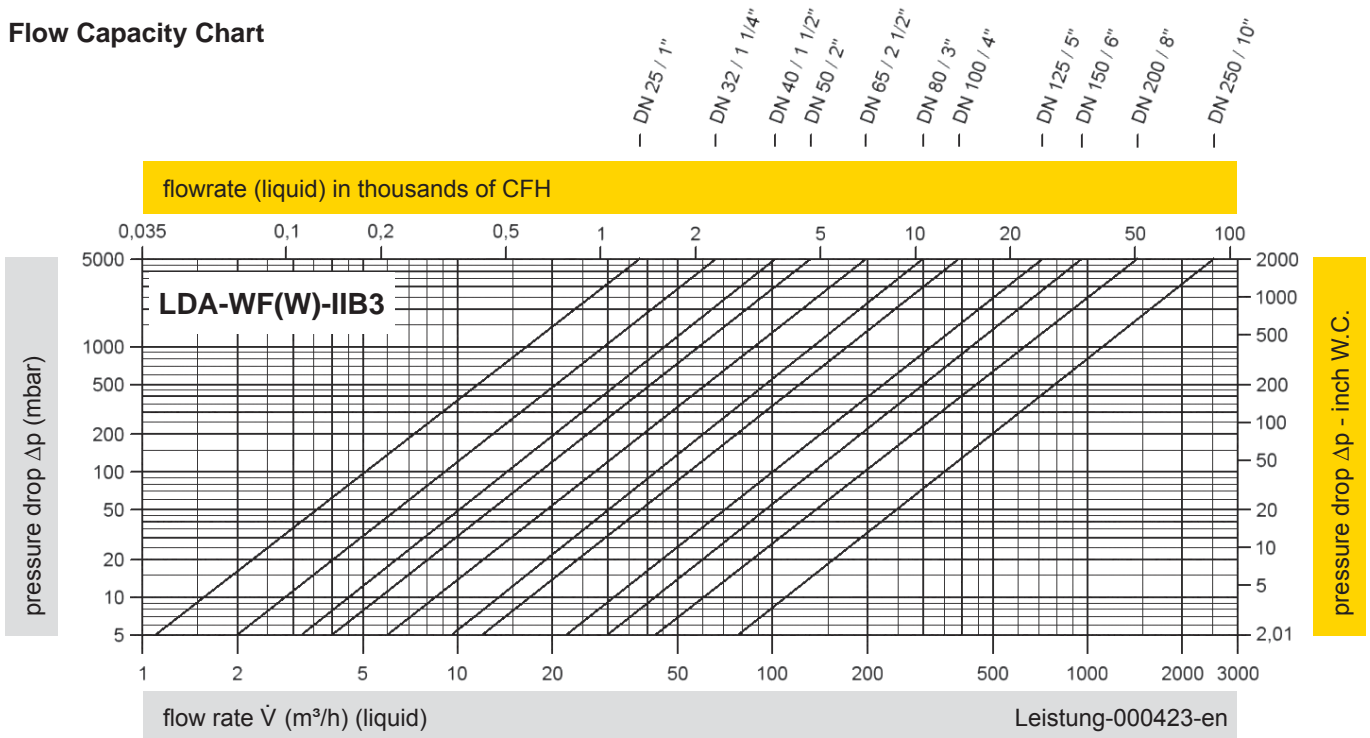

$$\text{Conversion: } \dot{V}_{\text{liquid}} = \dot{V}_{\text{water}} * \sqrt{\frac{\rho_{\text{water}}}{\rho_{\text{liquid}}}}$$

The volume flow \dot{V} in m^3/h was determined with water according to DIN EN 60534 at a temperature $T_n = 15^\circ\text{C}$ and an atmospheric pressure $p_n = 1,013 \text{ bar}$, kinematic viscosity $\nu = 10^{-6} \text{ m}^2/\text{s}$.

To avoid electrostatic charge of flammable liquids the maximum flow is limited (refer to BG-Regulation 132, CENELEC-Report CLC/TR 50404).





Liquid Detonation Flame Arrester

for filling lines - internal installation



PROTEGO® LDA

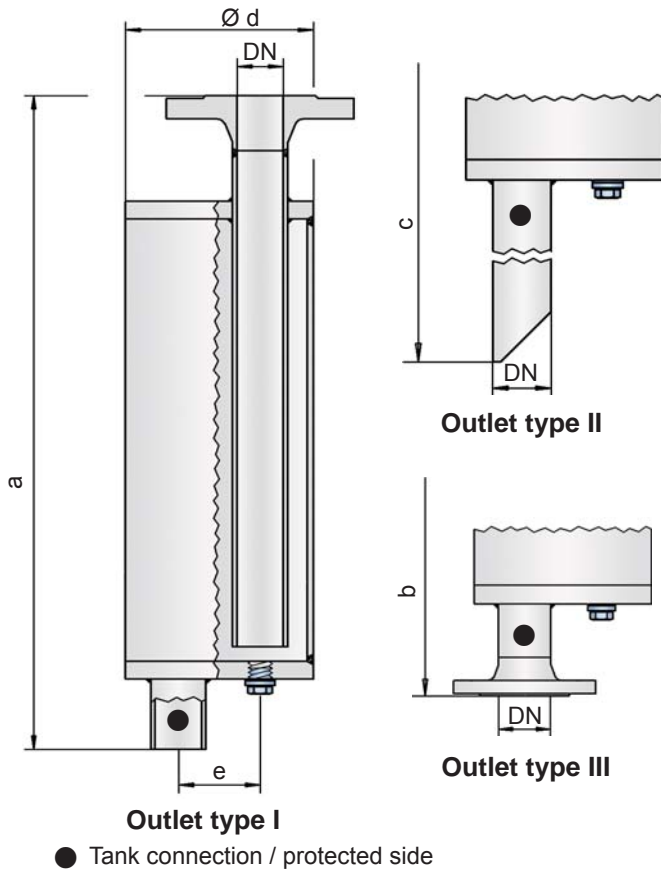

The device is installed inside the tank at the end of the line and prevents the combustion from being transferred into the tank if the explosive atmosphere ignites. The liquid detonation arresters function according to the siphon principle in which the liquid product serves as a liquid barrier to flame propagation.

When a highly accelerated pipe deflagration or detonation occurs, the combustion pressure and flame propagation speed is first substantially reduced by the design and converted into a low-energy deflagration that is then stopped by the remaining immersion liquid.

The application range for the device is a product vapour/air mixture temperature up to $+60^{\circ}\text{C} / 140^{\circ}\text{F}$ and an absolute pressure up to 1.1 bar / 15.9 psi. This covers all of the possible operating conditions of empty lines for flammable liquids. The liquid detonation arrester is pressure-resistant up to 10 bar / 145 psi. The device protects against nearly all flammable liquids, and is approved for explosion groups IIA to IIB3 (NEC group D to C MESH ≥ 0.65 mm).

Type-approved in accordance with the current ATEX Directive and EN ISO 16852 as well as other international standards.

Special Features and Advantages

- simple construction that helps prevent soiling
- low pressure loss
- provides protection from deflagrations and stable detonations
- useful for nearly all flammable liquids
- meets TRbF* requirements
- deliverable with different outlets

*TRbF = technical regulations for flammable liquids

Function and Description

The PROTEGO® LDA series of liquid detonation arresters was developed for storage tank filling lines that are not continuously filled with product and sometimes contain a combustible mixture.

Table 1: Dimensions

Dimensions in mm / inches

To select the nominal size (DN), please use the flow capacity chart on the following pages

DN	25 1"	32 1 1/4"	40 1 1/2"	50 2"	65 2 1/2"	80 3"	100 4"	125 5"	150 6"	200 8"	250 10"
a	500 / 19.69	580 / 22.83	700 / 27.56	700 / 27.56	825 / 32.48	925 / 36.42	1050 / 41.34	1150 / 45.28	1350 / 53.15	1650 / 64.96	2000 / 78.74
b	538 / 21.18	620 / 24.41	745 / 29.33	745 / 29.33	870 / 34.25	975 / 38.39	1102 / 43.39	1205 / 47.44	1405 / 55.31	1712 / 67.40	2068 / 81.42
c	725 / 28.54	805 / 31.69	925 / 36.42	925 / 36.42	1050 / 41.34	1145 / 45.08	1270 / 50.00	1380 / 54.33	1580 / 62.20	1880 / 74.02	2300 / 90.55
d	115 / 4.53	140 / 5.51	168 / 6.61	168 / 6.61	220 / 8.66	245 / 9.65	325 / 12.80	356 / 14.02	500 / 19.69	600 / 23.62	700 / 27.56
e	50 / 1.97	58 / 2.28	65 / 2.56	65 / 2.56	95 / 3.74	105 / 4.13	135 / 5.31	155 / 6.10	200 / 7.87	250 / 9.84	300 / 11.81

Table 2: Selection of the explosion group

MESG	Expl. Gr. (IEC/CEN)	Gas Group (NEC)	
> 0,90 mm	IIA	D	Special approvals upon request
≥ 0,65 mm	IIB3	C	

Table 3: Specification of max. operating temperature

≤ 60°C / 140°F	T maximum allowable operating temperature in °C	
-	Designation	higher operating temperatures upon request

Table 4: Material selection for housing

Design	A	B	
Housing	Steel	Stainless Steel	Special materials upon request
Gasket	PTFE	PTFE	

Table 5: Flange connection type

EN 1092-1; Form B1	other types upon request
ASME B16.5; 150 lbs RFSF	

Table 6: Outlet type

Straight pipe	I	other types upon request
Beveled pipe	II	
EN 1092-1; Form B1	III	
ASME B16.5; 150 lbs RFSF	III	

Flow Capacity Chart

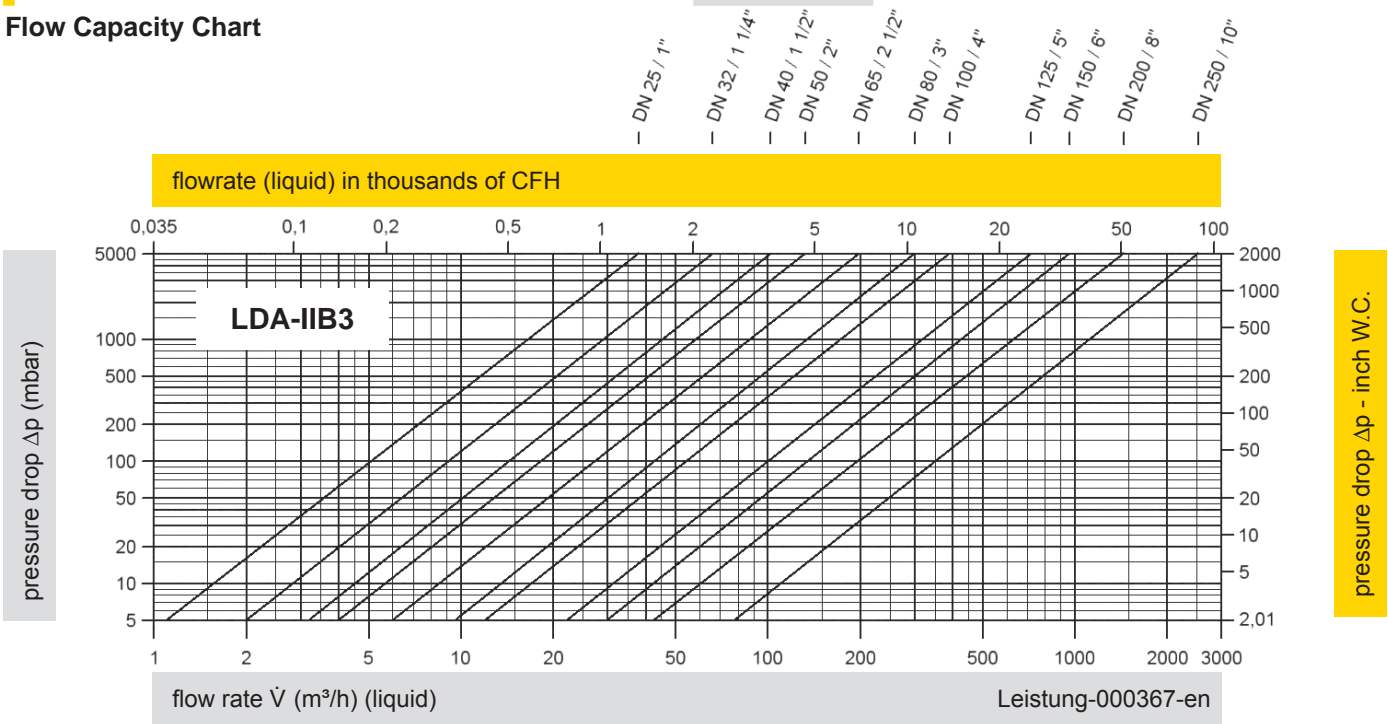

Conversion: $\dot{V}_{liquid} = \dot{V}_{water} * \sqrt{\frac{\rho_{water}}{\rho_{liquid}}}$

The volume flow \dot{V} in m³/h was determined with water according to DIN EN 60534 at a temperature $T_n = 15^\circ\text{C}$ and an atmospheric pressure $p_n = 1,013$ bar, kinematic viscosity $\nu = 10^{-6}$ m²/s.

To avoid electrostatic charge of flammable liquids the maximum flow is limited (refer to BG-Regulation 132, CENELEC-Report CLC/TR 50404).





Liquid Detonation Flame Arrester

for filling and drain lines - internal installation



PROTEGO® LDA-F

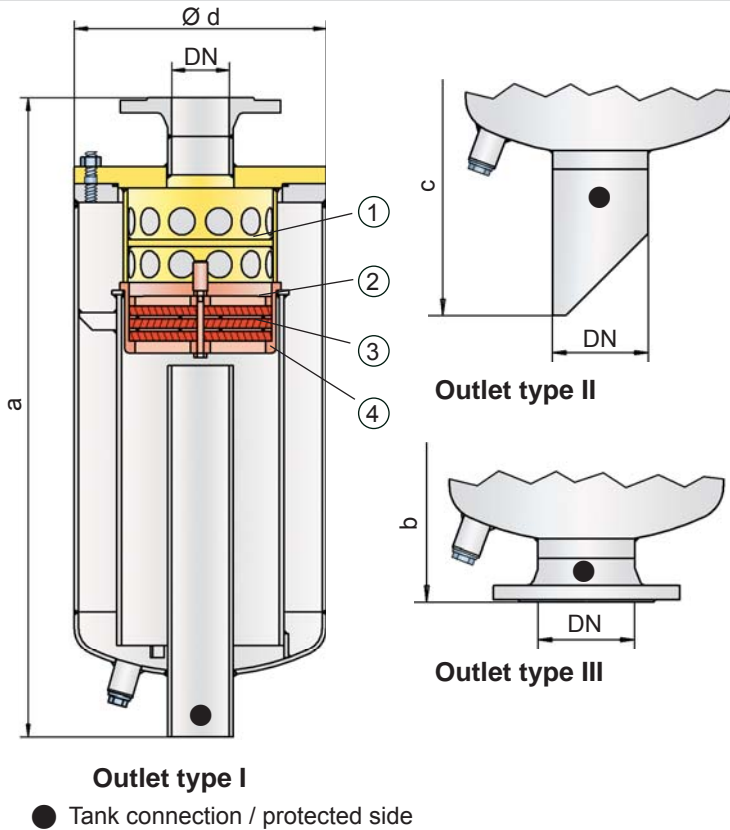

conditions of use. The device is installed inside the container at the end of the line and prevents the combustion from being transferred into the tank if the explosive atmosphere ignites. The PROTEGO® LDA-F series of liquid detonation arresters combines the classic PROTEGO® flame arrester design with the siphon principle in which the liquid product serves as a barrier to flame propagation.

When a highly accelerated pipe deflagration or detonation occurs, the combustion pressure and flame propagation speed is first substantially reduced by the design and converted into a low-energy deflagration that is then stopped by the remaining immersion liquid and the PROTEGO® flame arrester.

The application limits for the device is product vapour/air mixture temperatures up to +60°C / 140°F and an absolute pressure up to 1.1 bar / 15.9 psi. This covers all of the possible operating conditions of empty lines for flammable liquids. The liquid detonation arrester in standard design is pressure-resistant up to 10 bar / 145 psi. The device protects against nearly all flammable liquids and is approved for explosion groups IIA to IIB3 (NEC group D and C MESH ≥ 0.65 mm).

Type-approved in accordance with the current ATEX Directive and EN ISO 16852 as well as other international standards.

Special Features and Advantages

- siphon protection offers a high degree of safety
- minimum risk of soiling
- low pressure loss
- provides protection from deflagrations and stable detonations
- useful for nearly all flammable liquids
- meets TRbF* requirements
- deliverable with different outlets

*TRbF = technical regulations for flammable liquids

Function and Description

The PROTEGO® LDA-F series of liquid detonation arresters was developed for storage tanks filling and drain lines that are not continuously filled with product and sometimes contain a combustible mixture. The integrated siphon protection (1) with PROTEGO® flame arrester unit (2) additionally prevents the liquid in which the lines are immersed from being siphoned off while the container is being drained. The PROTEGO® flame arrester consists of several FLAMEFILTER® discs (3) and spacers firmly held in a FLAMEFILTER® cage (4). The number of FLAMEFILTER® discs and their gap size depends on the arresters

Table 1: Dimensions

Dimensions in mm / inches

To select the nominal size (DN), please use the flow capacity chart on the following pages

DN	25 1"	32 1 1/4"	40 1 1/2"	50 2"	65 2 1/2"	80 3"	100 4"	125 5"	150 6"	200 8"	250 10"
a	550 / 21.65	550 / 21.65	650 / 25.59	650 / 25.59	850 / 33.46	875 / 34.45	1050 / 41.34	1250 / 49.21	1450 / 57.09	1600 / 62.99	1975 / 77.76
b	588 / 23.15	590 / 23.23	692 / 27.24	695 / 27.36	895 / 35.24	925 / 36.42	1102 / 43.39	1305 / 51.38	1505 / 59.25	1662 / 65.43	2043 / 80.43
c	775 / 30.51	775 / 30.51	875 / 34.45	875 / 34.45	1075 / 42.32	1095 / 43.11	1270 / 50.00	1480 / 58.27	1680 / 66.14	1830 / 72.05	2275 / 89.57
d	140 / 5.51	140 / 5.51	220 / 8.66	220 / 8.66	275 / 10.83	275 / 10.83	356 / 14.07	457 / 17.99	508 / 20.00	600 / 23.62	711 / 27.99

Table 2: Selection of the explosion group

MESH	Expl. Gr. (IEC/CEN)	Gas Group (NEC)	
> 0,90 mm	IIA	D	Special approvals upon request
$\geq 0,65$ mm	IIB3	C	



Stabilized FLAMEFILTER®
Discs (Flyer pdf)

Table 3: Specification of max. operating temperature

≤ 60°C / 140°F	Tmaximum allowable operating temperature in °C	higher operating temperatures upon request
-	Designation	

Table 4: Material selection for housing

Design	A	B	Special materials upon request
Housing	Steel	Stainless Steel	
Shock absorber	Steel	Stainless Steel	
Gasket	FPM	PTFE	
Flame arrester unit	A	A	

Table 5: Material for flame arrester unit

Design	A	* the FLAMEFILTER® are also available in the materials Tantalum, Inconel, Copper, etc. when the listed housing and cage materials are used.
FLAMEFILTER® cage	Stainless Steel	
FLAMEFILTER® *	Stainless Steel	
Spacer	Stainless Steel	

Table 6: Flange connection type

EN 1092-1; Form B1	other types upon request
ASME B16.5; 150 lbs RFSF	

Table 7: Outlet type

Straight pipe	I	other types upon request
Beveled pipe	II	
EN 1092-1; Form B1	III	
ASME B16.5; 150 lbs RFSF	III	

Flow Capacity Chart

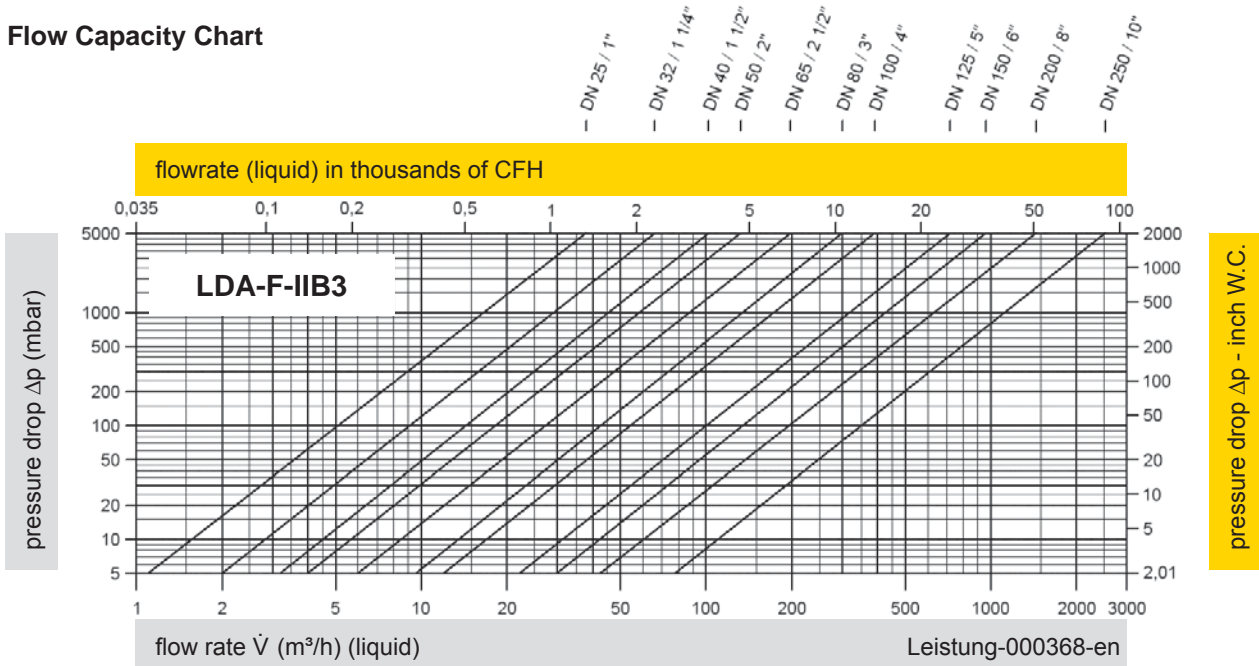

Conversion: $\dot{V}_{liquid} = \dot{V}_{water} * \sqrt{\frac{\rho_{water}}{\rho_{liquid}}}$

The volume flow \dot{V} in m³/h was determined with water according to DIN EN 60534 at a temperature $T_n = 15^\circ\text{C}$ and an atmospheric pressure $p_n = 1,013 \text{ bar}$, kinematic viscosity $\nu = 10^{-6} \text{ m}^2/\text{s}$. To avoid electrostatic charge of flammable liquids the maximum flow is limited (refer to BG-Regulation 132, CENELEC-Report CLC/TR 50404).



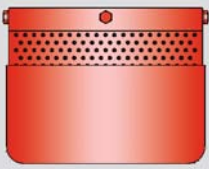

Detonation Flame Arrester

Detonation-proof foot valve for suction lines

PROTEGO® EF/V-IIB3

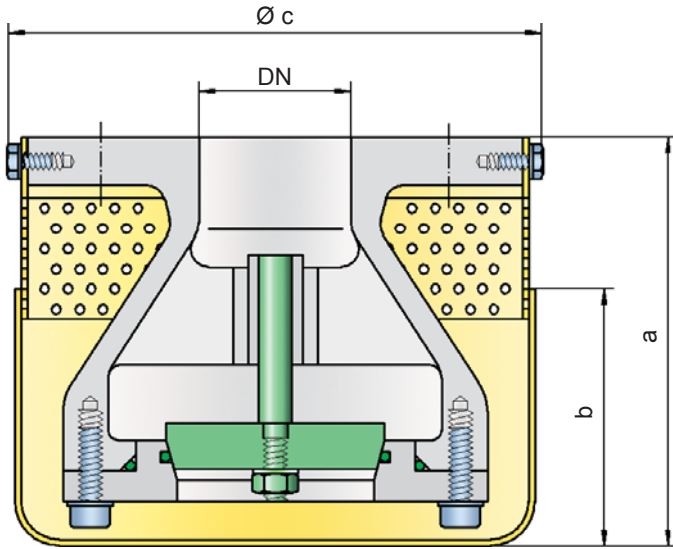

Combustible mixtures can arise in filling and drain lines of storage containers that are not always filled with product. With the ignition of the explosive atmosphere, highly accelerated pipe deflagration or detonations can arise. The detonation-proof foot valve prevents the combustion from being transmitted into the tank and destroying it. The design of the foot valve ensures that the strainer is always filled with residual product. Together with the special valve design, this combination prevents flame flash back from the inside out.

The application limits for the device are a product vapour/air mixture temperature up to +60°C / 140°F and an absolute pressure up to 1.1 bar / 15.9 psi. This covers all of the possible operating conditions of empty lines for flammable liquids.

The device protects against nearly all flammable liquids, and is permitted for explosion group IIB3 (C MESG ≥ 0.65 mm).

Type-approved in accordance with the current ATEX Directive and EN ISO 16852 as well as other international standards.

Function and Description

The PROTEGO® EF/V-IIB3 detonation-safe foot valve protects the suction line in a storage tank. The nearly service-free device is installed at the end of the emptying line within the tank. When a pump draws, the valve opens at an approximate underpressure of 30 mbar / 12 inch W.C. . When the pump is turned off, the device functions as a check valve and prevents the line from emptying. This is very helpful when the pump is restarted.

Special Features and Advantages

- almost service-free
- the check valve makes it easier to start the pump
- provides protection from deflagrations and stable detonations
- applicable to nearly all flammable liquids
- meets TRbF* 20 requirements
- the special strainer prevents solid particles from entering

*TRbF = technical regulations for flammable liquids

Table 1: Dimensions

Dimensions in mm / inches

To select the nominal size (DN), please use the flow capacity chart on the following page

DN	25 1"	32 1 ¼"	40 1 ½"	50 2"	65 2 ½"	80 3"	100 4"	125 5"	150 6"	200 8"	250 10"
a	125 / 4.92	125 / 4.92	135 / 5.31	135 / 5.31	160 / 6.29	160 / 6.29	200 / 7.87	235 / 9.25	260 / 10.24	400 / 15.75	450 / 17.72
b	85 / 3.35	85 / 3.35	85 / 3.35	85 / 3.35	95 / 3.74	95 / 3.74	125 / 4.92	130 / 5.12	135 / 5.31	175 / 6.89	200 / 7.81
c	155 / 6.10	155 / 6.10	180 / 7.09	180 / 7.09	210 / 8.27	210 / 8.27	250 / 9.84	310 / 12.20	365 / 14.37	480 / 18.90	565 / 22.24

Table 2: Selection of the explosion group

MESG	Expl. Gr. (IEC/CEN)	Gas Group (NEC)	Special approvals upon request
≥ 0,65 mm	IIB3	C	

Table 3: Specification of max. operating temperature

≤ 60°C / 140°F	T maximum allowable operating temperature in °C	higher operating temperatures upon request
-	Designation	

Table 4: Material selection for housing

Design	A	B	C	D	Special materials upon request
Housing	Steel	Stainless Steel	Steel	Stainless Steel	
Valve	Stainless Steel	Stainless Steel	Stainless Steel	Stainless Steel	
Gasket (Valve)	PTFE	PTFE	PTFE	PTFE	
Gasket (Housing)	FPM	FPM	PTFE	PTFE	
Strainer	Stainless Steel	Stainless Steel	Stainless Steel	Stainless Steel	

Table 5: Flange connection type

EN 1092-1; Form A	other types upon request
ASME B16.5; 150 lbs FF5F	

Flow Capacity Chart

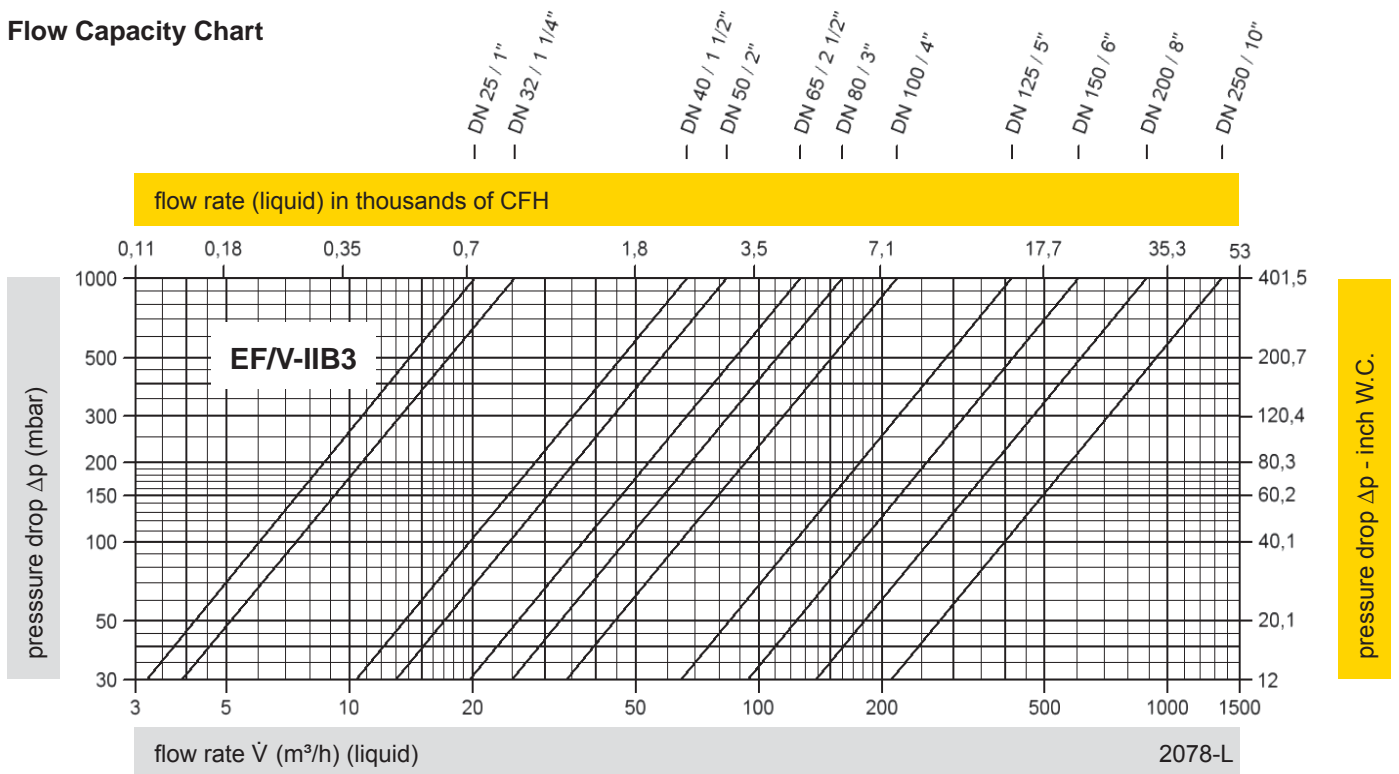

$$\text{Conversion: } \dot{V}_{\text{liquid}} = \dot{V}_{\text{water}} * \sqrt{\frac{\rho_{\text{water}}}{\rho_{\text{liquid}}}}$$

The volume flow \dot{V} in m³/h was determined with water according to DIN EN 60534 at a temperature $T_n = 15^\circ\text{C}$ and an atmospheric pressure $p_n = 1,013$ bar, kinematic viscosity $\nu = 10^{-6}$ m²/s. To avoid electrostatic charge of flammable liquids the maximum flow is limited (refer to BG-Regulation 132, CENELEC-Report CLC/TR 50404).



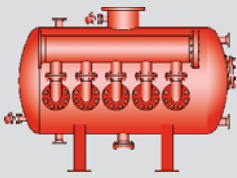

Hydraulic Flame Arresters

deflagration proof, detonation proof and short-time burning proof

PROTEGO® TS/P, TS/E and TS/W

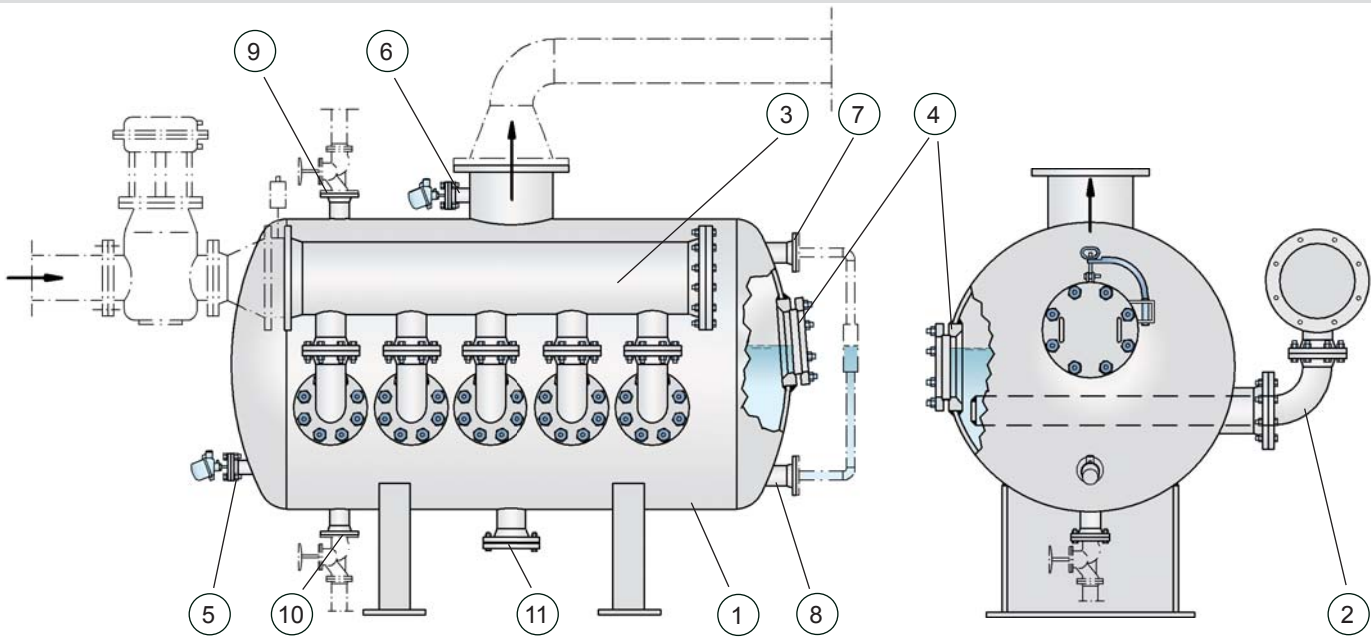

Function and Description

The PROTEGO® hydraulic flame arresters of type TS/... are mainly designed to protect process plants which are connected to waste thermal combustion units. Hydraulic flame arresters of the TS/... series are particularly suitable to protect plants which supply heavily contaminated, sticking, polymerizing or even foaming substances into thermal combustion units. Generally it is necessary to protect the plant against in-line deflagration, stable detonation and endurance burning hazards taking into account the plant's operating conditions.

The PROTEGO® TS/... series of hydraulic flame arresters guarantees flame transmission protection during short time burning, deflagration and stable detonation of gas/air mixtures or product vapour/air mixtures of the relevant explosion groups in all ranges of flammable concentrations up to a service temperature of +60 °C / 140 °F and under an operating pressure up to 1.1 bar / 15 psi (absolute).

Flame arresters of type TS/... are the only hydraulic flame arresters which have been tested and certified for substances of all explosion groups.

Type-approved in accordance with the current ATEX Directive and EN ISO 16852 as well as other international standards.

Hydraulic flame arresters of series TS/... mainly consist of the immersion tank (1) with off gas nozzle and connection nozzles for the sparge pipes, the sparge pipes (2) with elbows and connection flanges as well as the manifolds (3) with connection flanges. To allow measurement of the immersion liquid temperature the tank (1) has a minimum of one nozzle (5), and for measuring the temperature of the off gas there is a minimum of one connection for each exhaust gas nozzle (6) for insertion of temperature sensors. Additionally the tank has two nozzles (7, 8) for level measurement, two nozzles (9, 10) for level control, and one nozzle (11) for draining. Inspection-glasses (4) are included for inspection of the immersion liquid and gas space. The sparge pipes can be pulled out of the hydraulic flame

arrester to allow cleaning of the drill holes and the pipes. At the off gas inlet the manifold has the required flange connection and the relevant number of nozzles for distributing the off gas into required number of sparge pipes.

In PROTEGO® hydraulic flame arresters of type TS/... the flammable mixtures are passed through a water seal with a defined immersion depth. The mixture flow is prorated up and passed to the individual sparge pipes. The sparge pipes have small drill holes and therefore produce defined bubble columns. In case of an ignition in the flowing gas mixture the flame is prevented from transmission into the inlet line. The following parameters have a significant effect on the flame arresting efficiency of the device in case of deflagrations, detonations or short time burning:

- Mixture volume flow,
- Immersion depth from the water seal's surface to the upper edges of the drill holes in the sparge pipes,
- Water temperature in the hydraulic flame arrester
- Sizes, form and density of the bubbles and therefore the precise drill hole diameter in the sparge pipes.

If the mixture ignites under certain operating conditions within the hydraulic flame arrester and burns directly on the liquid surface prevention of flame transmission can only be guaranteed for a limited amount of time. Therefore a number of temperature sensors are installed in the gas space and when reaching a specified temperature they trigger appropriate emergency functions upstream in the system connected (shut down, inerting, etc.).

A high accuracy volume flow meter must be installed as an essential technical safety element. It has to guarantee that the maximum allowable volume flow, on which the design of the hydraulic flame arrester has been based, is recorded and limited so that emergency functions are triggered if the off gas volumes exceed the safe level. In addition, a minimum flame-transmission-proof immersion height is necessary, i.e. an

adequate water level must be guaranteed by suitable measuring equipment.

The pressure loss of a hydraulic flame arrester at maximum volume flow equals losses at inflow and outflow of approximately 12 to 18 mbar / 4.8 to 7.2 In W.C. plus the immersion depth, e.g. 350 mm = 35 mbar / 13.8 In = 14.1 In W.C., so the total is between 47 and 53 mbar / 18.9 and 21.3 In W.C.

Instrumentation

The efficiency and function of the PROTEGO TS/... hydraulic flame arrester requires measurement and control equipment for the filling level, volume flow and temperature of the system. It is necessary to maintain the minimum operating immersion depth and measure the maximum mixture volume flow, maximum gas temperature and minimum water temperature. If the safe operational envelope is exceeded, the measurement and control equipment must quickly initiate automatic emergency functions. Measurement and control safety equipment must be explosion proof and approved for zone 0.

Measurement and control equipment is not part of standard scope of supply.

Maximum Volume Flow

The maximum allowable operating volume flow is calculated by multiplying the number of sparge pipes by the maximum allowable operating volume flow for each sparge pipe at its immersion depth.

In special cases it may not be necessary to measure the volume flow provided that the volume flow limitation is guaranteed by other components in the system such as a conveyor system or a choke in combination with a decompression device.

Level Measurement and Level Control

The operating immersion depth should be kept constant by a controlled automatic water supply so that the level does not fall below the minimum immersion depth.

Temperature Measurement and Limitation

In order to prevent endurance burning in the arrester the off gas supply must be stopped automatically when the temperature exceeds $T = 80^{\circ}\text{C} / 176^{\circ}\text{F}$ at the gas outlet. Temperature sensors monitor the mixture temperature.

If the water temperature falls below $T < 10^{\circ}\text{C} / 50^{\circ}\text{F}$ (danger of freezing) or rises above the limiting temperature in the gas space, a quick action gate valve must shut automatically and stop the off gas supply.

As an option temperature sensors can be supplied.

Design Types and Specifications

The hydraulic flame arresters are designated by explosion groups, diameters and numbers of sparge pipes. They are designed in modules and type tested for the corresponding explosion groups.

For explosion group IIA (NEC group D)

Types TS/P 1000 / 40" or TS/P 2000 / 80"

For explosion group IIB3 (NEC group C)
Types TS/E 1000 / 40" or TS/E 2000 / 80"

For explosion group IIC (NEC group B)
Types TS/W 1000 / 40" or TS/W 2000 / 80"

The number of sparge pipes depends on the design volume flow.

Example: TS/E-1000-5 is a hydraulic flame arrester for substances of explosion group IIB3 (NEC group C) with a diameter of 1000 mm / 40" and 5 sparge pipes.

Dimensions

Standard diameters of TS/... series hydraulic flame arresters are 1000 mm / 40" and 2000 mm / 80". Alternatively diameters from 600 mm / 24" to 3000 mm / 120" are available depending on the off gas volume flow. Hydraulic flame arresters with diameters from 2000 mm / 80" and larger have a restriction plate to prevent wave motions in the sparging zone. All outlet headers and inlet headers as well as internal are components relevant for technical safety, and it is therefore not allowed to change their design and function nor that of the hydraulic flame arrester!

Material Selection

The material selection is determined by the exhaust air process data. Tank designs of steel, stainless steel, coated steel or steel lined with ECTFE or resin are available depending on the application. The sparge pipes are made of stainless, hastelloy or plastic.

Flange Connection Type

The standard flange connections are made to EN 1092-1; Form B1. Optionally, the connecting flanges can be made according to any international standard.

Selection and Design

The static immersion depth and the resistance due to dynamic flow in the sparge pipes and the off gas supply lines create the total pressure loss. The manufacturer's advice about technical safety is absolutely necessary in any case!

For particularly corrosive mixtures the hydraulic flame arrester may be coated. The materials of tank, installations and sparge pipes have to be selected according to the corrosive properties of the mixture.

Data Necessary for Specification

The following operational data is required for the technical safety of the hydraulic flame arrester design:

Off gas volume flow taking into account the maximum possible volume flow (m^3/h or CFH)

Off gas composition (vol.%)

Operating temperature ($^{\circ}\text{C}$ or $^{\circ}\text{F}$)



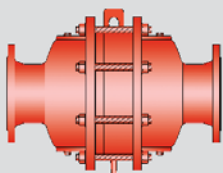

In-Line Detonation Flame Arrester

for unstable and stable detonations and deflagrations in a straight through design with a shock tube, bidirectional

PROTEGO® DA-UB

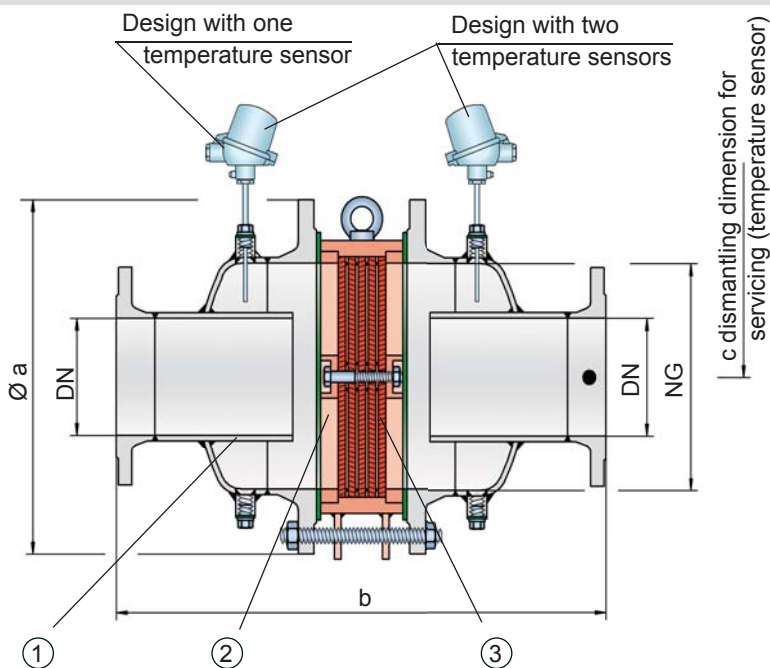

● Connection to the protected side (only for type DA-UB-T-....)

Function and Description

The in-line detonation flame arresters type PROTEGO® DA-UB are the newest generation of flame arresters. On the basis of fluid dynamic and explosion-dynamic calculations and decades of experience from field tests, a line was developed that offers minimum pressure loss and maximum safety. The device uses the *Shock Wave Guide Tube Effect (SWGTE)* to separate the flame front and shock wave. The result is an in-line detonation flame arrester without a classic shock absorber, and the use of flame-extinguishing elements is minimized.

The devices are symmetrical and offer bidirectional flame arresting for deflagrations, stable and unstable detonations. The arrester essentially consists of two housing parts with an integrated shock tube (1) and the PROTEGO® flame arrester unit (2) in the center. The PROTEGO® flame arrester unit is modular and consists of several FLAMEFILTER® discs (3) and spacers firmly held in a FLAMEFILTER® cage. The number of FLAMEFILTER® discs and their gap size depends on the arrester's conditions of use.

By indicating the operating parameters such as temperature, pressure and explosion group and the composition of the fluid, the optimum detonation arrester can be selected from a series of approved devices. PROTEGO® DA-UB flame arresters are available for explosion groups IIA to IIB3 (NEC group D to C MESH ≥ 0.65 mm).

The standard design can be used up to an operating temperature of +60°C / 140°F and an absolute operating pressure up to 1.1 bar / 15.9 psi. **Numerous devices with special approval can be supplied for higher pressures (see table 3) and higher temperatures.**

Type-approved in accordance with the current ATEX Directive and EN ISO 16852 as well as other international standards.

Special Features and Advantages

- optimized performance from the patented *Shock Wave Guide Tube Effect (SWGTE)*
- less number of FLAMEFILTER® discs from the use of the patented shock tube (SWGTE)
- modular flame arrester unit enables each individual FLAMEFILTER® discs to be replaced and cleaned
- different series allow increase of FLAMEFILTER® size for given flange connection resulting in lower pressure drop across the device
- service-friendly design
- expanded application range for higher operating temperatures and pressures
- bidirectional operation as well as any direction of flow and installation position
- possible installation of temperature sensors
- minimum pressure loss and associated low operating and life-cycle cost
- cost efficient spare parts

Design Types and Specifications

There are four different designs available:

Basic in-line detonation flame arrester **DA-UB - [] - []**

In-line detonation flame arrester with integrated temperature sensor* as additional protection against short time burning **DA-UB - [T] - []**

In-line detonation flame arrester with two integrated temperature sensors* for additional protection against short time burning from both sides **DA-UB - [TB] - []**

In-line detonation flame arrester with heating jacket **DA-UB - [H] - []**

Additional special flame arresters upon request

*Resistance thermometer for device group II, category (1) 2 (GII cat. (1) 2)



Stabilized FLAMEFILTER®
Discs (Flyer pdf)



New PROTEGO® Flame Arrester Unit unique
maintenance friendly design (Flyer pdf)

Table 1: Dimensions

Dimensions in mm / inches

To select nominal width/nominal size (NG/DN) - combination, please use the flow capacity charts on the following pages					Additional nominal width/nominal size (NG/DN) - combinations for improved flow capacity upon request					
standard										
NG	150 6"	150 6"	200 8"	300 12"	400 16"	500 20"	600 24"	700 28"	800 32"	1400 56"
DN	≤ 50 2"	80 3"	≤ 100 4"	≤ 150 6"	≤ 200 8"	≤ 250 10"	≤ 300 12"	≤ 350 14"	≤ 400 16"	≤ 600 24"
a	285 / 11.22	285 / 11.22	340 / 13.39	445 / 17.52	565 / 22.24	670 / 26.38	780 / 30.71	895 / 35.24	1015 / 39.96	1675 / 65.94
b	IIA -P1.1				700 / 27.56	800 / 31.50	1000 / 39.37	1200 / 47.24	1400 / 55.12	2200 / 86.61
	IIA -P1.2	388 / 15.28	388 / 15.28	488 / 19.21	626 / 24.65					
	IIB3 -P1.1			500 / 19.69	638 / 25.12	724 / 28.50	824 / 32.44	1000 / 39.37	1200 / 47.24	1400 / 55.12
	IIB3 -P1.2	388 / 15.28	388 / 15.28							
c	500 / 19.69	500 / 19.69	520 / 20.47	570 / 22.44	620 / 24.41	670 / 26.38	720 / 28.35	770 / 30.31	820 / 32.28	1060 / 41.73

Table 2: Selection of the explosion group

MESG	Expl. Gr. (IEC/CEN)	Gas Group (NEC)	Special approvals upon request
> 0,90 mm	IIA	D	
≥ 0,65 mm	IIB3	C	

Table 3: Selection of max. operating pressure

NG		150 6"	150 6"	200 8"	300 12"	400 16"	500 20"	600 24"	700 28"	800 32"	1400 56"
DN		≤ 50 2"	80 3"	≤ 100 4"	≤ 150 6"	≤ 200 8"	≤ 250 10"	≤ 300 12"	≤ 350 14"	≤ 400 16"	≤ 600 24"
Expl. Gr.	IIA	P _{max}	1.8 / 26.1	1.8 / 26.1	1.6 / 23.2	1.6 / 23.2	1.1 / 15.9	1.1 / 15.9	1.1 / 15.9	1.1 / 15.9	1.1 / 15.9
	IIB3	P _{max}	1.5 / 21.7	1.5 / 21.7	1.5 / 21.7	1.5 / 21.7	1.1 / 15.9	1.1 / 15.9	1.1 / 15.9	1.1 / 15.9	1.1 / 15.9

P_{max} = maximum allowable operating pressure in bar / psi (absolute), higher operating pressure upon request
in-between size up to P_{max} upon request

Table 4: Specification of max. operating temperature

≤ 60°C / 140°F	Tmaximum allowable operating temperature in °C	higher operating temperatures upon request
-	Designation	



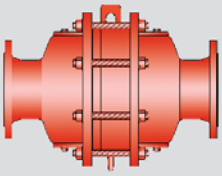

In-Line Detonation Flame Arrester

for unstable and stable detonations and deflagrations in a straight through design with a shock tube, bidirectional

PROTEGO® DA-UB

Table 5: Material selection for housing

Design	A	B	C
Housing	Steel	Stainless Steel	Hastelloy
Heating jacket (DA-UB-(T)-H-...)	Steel	Stainless Steel	Stainless Steel
Gasket	PTFE	PTFE	PTFE
Flame arrester unit	A	B, C	D

The housing is also available in Steel with an ECTFE coating.

Special materials upon request

Table 6: Material combinations of the flame arrester unit

Design	A	B	C	D
FLAMEFILTER® cage	Steel	Stainless Steel	Stainless Steel	Hastelloy
FLAMEFILTER® *	Stainless Steel	Stainless Steel	Hastelloy	Hastelloy
Spacer	Stainless Steel	Stainless Steel	Hastelloy	Hastelloy

*the FLAMEFILTER® are also available in the materials Tantalum, Inconel, Copper, etc. when the listed housing and cage materials are used.

Special materials upon request

Table 7: Flange connection type

EN 1092-1; Form B1	other types upon request
ASME B16.5; 150 lbs RFSF	

* P1.2

NG / DN
 150/50 (6"/2") *
 150/80 (6"/3") *
 200/100 (8"/4") *
 300/150 (12"/6") *
 400/200 (16"/8")
 500/250 (20"/10")
 600/300 (24"/12")
 700/350 (28"/14")
 800/400 (32"/16")

airflow in thousands of CFH

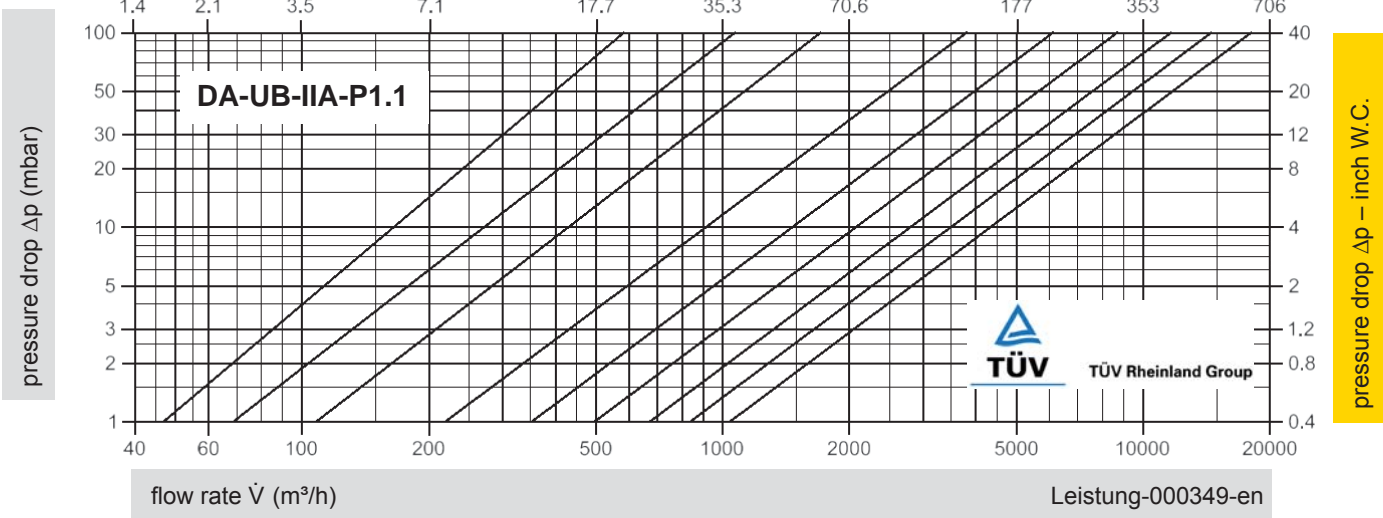

flow rate \dot{V} (m³/h)

Leistung-000349-en

* P1.2

NG / DN
 150/50 (6"/2") *
 150/80 (6"/3") *
 200/100 (8"/4") *
 300/150 (12"/6")
 400/200 (16"/8")
 500/250 (20"/10")
 600/300 (24"/12")
 700/350 (28"/14")
 800/400 (32"/16")

airflow in thousands of CFH

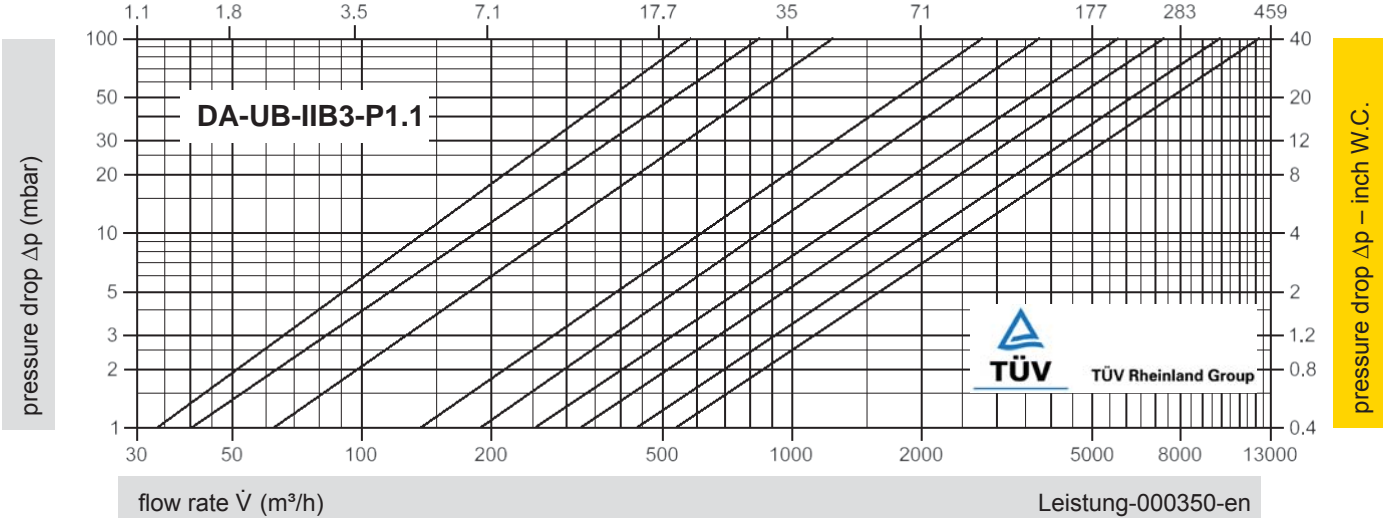

flow rate \dot{V} (m³/h)

Leistung-000350-en

The flow capacity charts have been determined with a calibrated and TÜV certified flow capacity test rig. Volume flow \dot{V} in (m³/h) and CFH refer to the standard reference conditions of air ISO 6358 (20°C, 1bar). Conversion to other densities and temperatures refer to Vol. 1: "Technical Fundamentals".



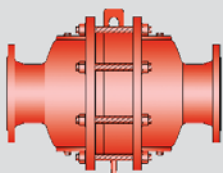

In-Line Detonation Flame Arrester

for unstable and stable detonations and deflagrations in a straight through design with shock absorber, bidirectional

PROTEGO® DA-CG

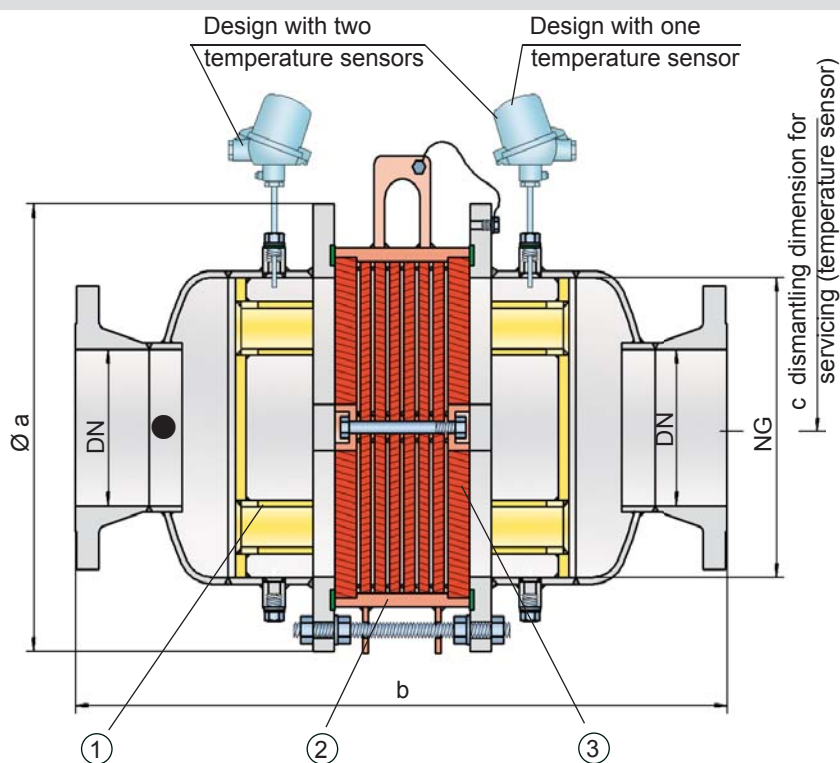

● Connection to the protected side (only for type DA-CG-T-....)

Function and Description

The PROTEGO® DA-CG series of detonation arresters was mainly developed for the North American market and optimized to meet the demands of the US Coast Guard. The devices are symmetrical and offer bidirectional flame arresting for deflagrations, stable and unstable detonations.

The speed of incoming detonations is greatly reduced by the effective shock absorber (1). This improves the flame extinction in the narrow gaps of the FLAMEFILTER® (3).

The flame arrester essentially consists of two housing parts with an integrated shock absorber and the PROTEGO® flame arrester unit (2) in the center. The PROTEGO® flame arrester unit is modular and consists of several FLAMEFILTER® discs and spacers firmly held in a FLAMEFILTER® cage. The number of FLAMEFILTER® discs and their gap size depends on the arrester's conditions of use.

By indicating the operating parameters such as the temperature, pressure and explosion group and the composition of the fluid, the optimum in-line detonation flame arrester can be selected. Type PROTEGO® DA-CG flame arresters are available for explosion groups IIA to IIB3 (NEC group D to C MESH ≥ 0.65 mm).

The standard design can be used up to an operating temperature of +60°C / 140°F and an absolute operating pressure acc. to table 3. **Devices with special approvals can be obtained for higher pressures and higher temperatures upon request.**

The flame arresters have been approved according to the American Standard 33 CFR part 154 and are accepted by the US Coast Guard.

Special Features and Advantages

- offers protection against deflagrations, stable and unstable detonations
- less number of FLAMEFILTER® discs from the use of the effective shock absorber
- modular flame arrester unit enables each individual FLAMEFILTER® discs to be replaced and cleaned
- different series allow increase of FLAMEFILTER® size for given flange connection resulting in lower pressure drop across the device
- service-friendly design
- also available for large nominal sizes
- expanded application range for higher operating temperatures and pressures
- bidirectional operation as well as any direction of flow and installation position
- Possible installation of temperature sensors
- minimum pressure loss and associated low operating and life-cycle cost
- cost efficient spare parts

Design Types and Specifications

There are three different designs available:

Basic in-line detonation flame arrester **DA-CG-**

In-line detonation flame arrester with integrated temperature sensor* as additional protection against short time burning from one side **DA-CG-**

Detonation arrester with two integrated temperature sensors* as additional protection against short time burning from both sides **DA-CG-**

Additional special flame arresters upon request

*Resistance thermometer for device group II, category (1) 2 (GII cat. (1) 2)

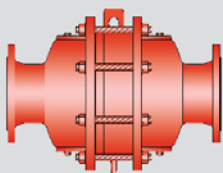

Table 1: Dimensions												Dimensions in mm / inches	
To select nominal width/nominal size (NG/DN) - combination, please use the flow capacity charts on the following pages						Additional nominal width/nominal size (NG/DN) - combinations for improved flow capacity upon request							
standard													
NG	150 6"	150 6"	200 8"	300 12"	400 16"	500 20"	600 24"	700 28"	800 32"	1000 40"	1200 48"		
DN	≤ 50 2"	80 3"	≤ 100 4"	≤ 150 6"	≤ 200 8"	≤ 250 10"	≤ 300 12"	≤ 350 14"	≤ 400 16"	≤ 500 20"	≤ 600 24"		
a	285 / 11.22	285 / 11.22	340 / 13.39	460 / 11.18	580 / 22.83	715 / 28.15	840 / 33.07	1025 / 40.35	1025 / 40.35	1255 / 49.41	1485 / 58.46		
b	650 / 25.59	650 / 25.59	700 / 27.56	800 / 31.50	900 / 35.43	1100 / 43.31	1250 / 49.21	1500 / 59.06	1500 / 59.06	1700 / 66.93	2000 / 78.74		
c	300 / 11.81	300 / 11.81	330 / 12.99	380 / 14.96	490 / 19.29	540 / 21.26	590 / 23.23	690 / 27.17	690 / 27.17	790 / 31.10	880 / 34.65		

Table 2: Selection of the explosion group			
MESG	Expl. Gr. (IEC/CEN)	Gas Group (NEC)	Special approvals upon request
> 0,90 mm	IIA	D	
≥ 0,65 mm	IIB3	C	

Table 3: Selection of max. operating pressure												
Expl. Gr.	NG	150 6"	150 6"	200 8"	300 12"	400 16"	500 20"	600 24"	700 28"	800 32"	1000 40"	1200 48"
	DN	≤ 50 2"	80 3"	≤ 100 4"	≤ 150 6"	≤ 200 8"	≤ 250 10"	≤ 300 12"	≤ 350 14"	≤ 400 16"	≤ 500 20"	≤ 600 24"
	IIA	P _{max}	1.2 / 17.4	1.2 / 17.4	1.2 / 17.4	1.2 / 17.4	1.2 / 17.4	1.2 / 17.4	1.2 / 17.4	1.2 / 17.4	1.2 / 17.4	1.2 / 17.4
	IIB3	P _{max}	1.6 / 23.2	1.6 / 23.2	1.6 / 23.2	1.6 / 23.2	1.6 / 23.2	1.6 / 23.2	1.6 / 23.2	1.6 / 23.26	1.6 / 23.2	1.6 / 23.2

P_{max} = maximum allowable operating pressure in bar / psi (absolute), higher operating pressure upon request



In-Line Detonation Flame Arrester

for unstable and stable detonations and deflagrations in a straight through design with shock absorber, bidirectional

PROTEGO® DA-CG

Table 4: Specification of max. operating temperature

≤ 60°C / 140°F	Tmaximum allowable operating temperature in °C	higher operating temperatures upon request
-	Designation	

Table 5: Material selection for housing

Design	A	B	Special materials upon request
Housing	Steel	Stainless Steel	
Gasket	PTFE	PTFE	
Flame arrester unit	A	B	

Table 6: Material combinations of the flame arrester unit

Design	A	B	*the FLAMEFILTER® are also available in the materials Tantalum, Inconel, Copper, etc. when the listed housing and cage materials are used.
FLAMEFILTER® cage	Steel	Stainless Steel	
FLAMEFILTER® *	Stainless Steel	Stainless Steel	
Spacer	Stainless Steel	Stainless Steel	

Special materials upon request

Table 7: Flange connection type

EN 1092-1; Form B1	other types upon request
ASME B16.5; 150 lbs RFSF	

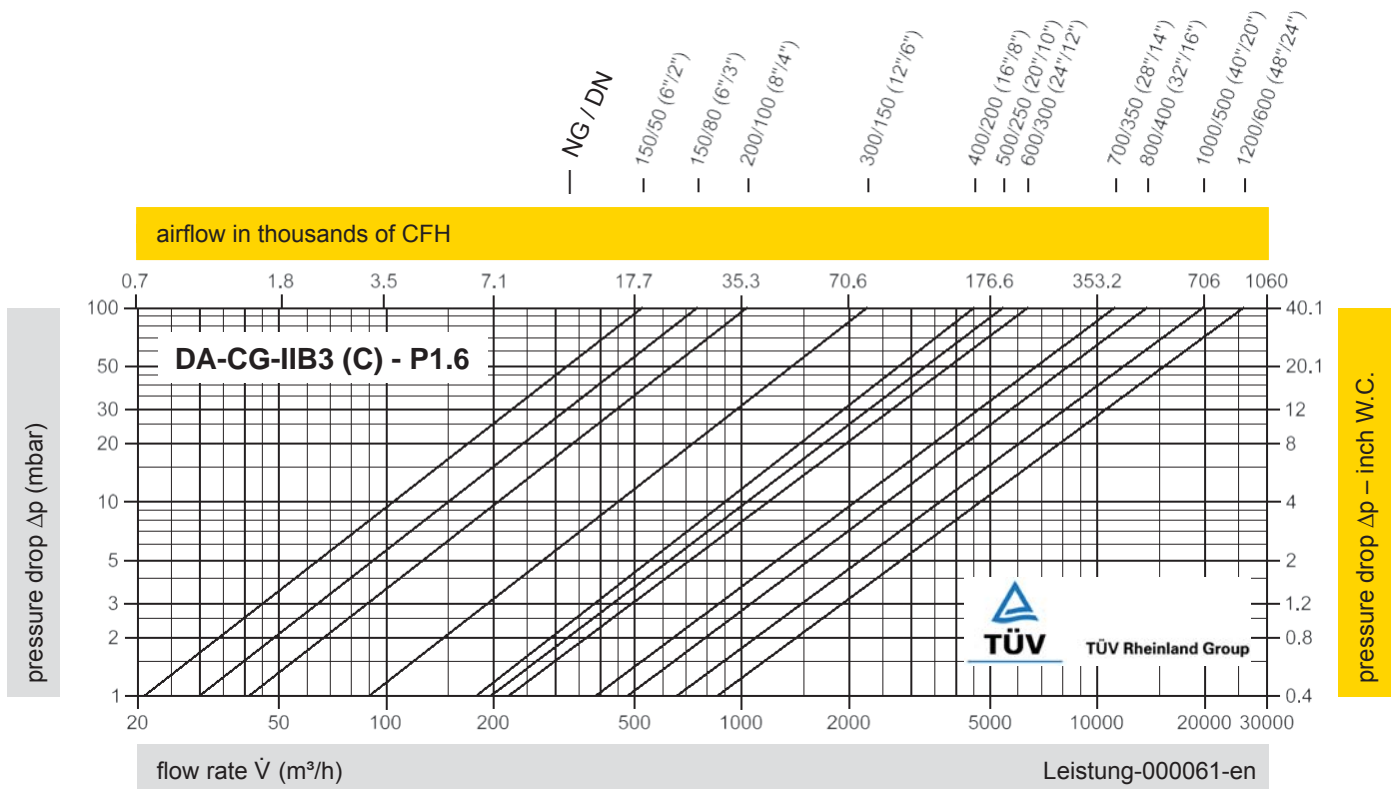
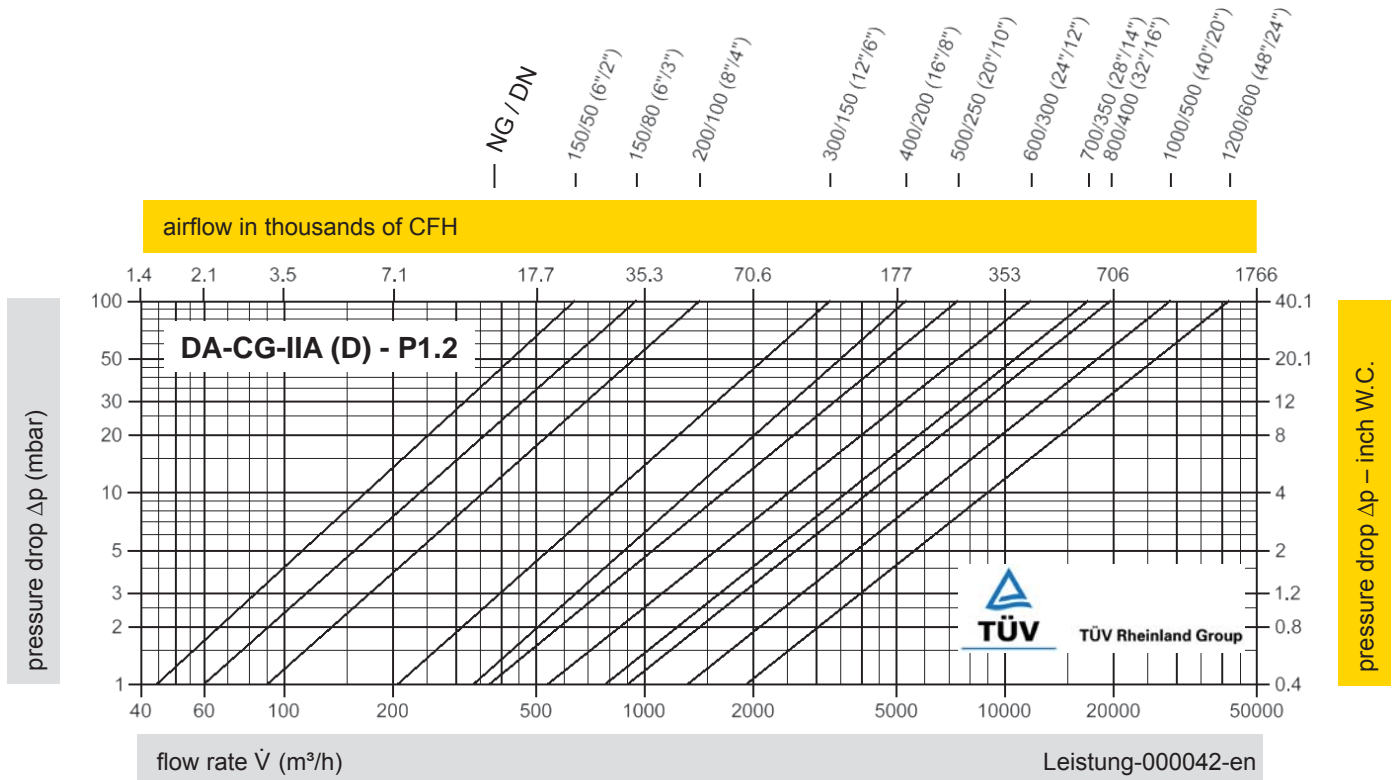

The flow capacity charts have been determined with a calibrated and TÜV certified flow capacity test rig. Volume flow \dot{V} in (m³/h) and CFH refer to the standard reference conditions of air ISO 6358 (20°C, 1bar). Conversion to other densities and temperatures refer to Vol. 1: "Technical Fundamentals".



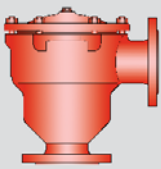

In-Line Detonation Flame Arrester

for unstable and stable detonations and deflagrations in right angle design with a shock absorber, unidirectional

PROTEGO® DR/EU

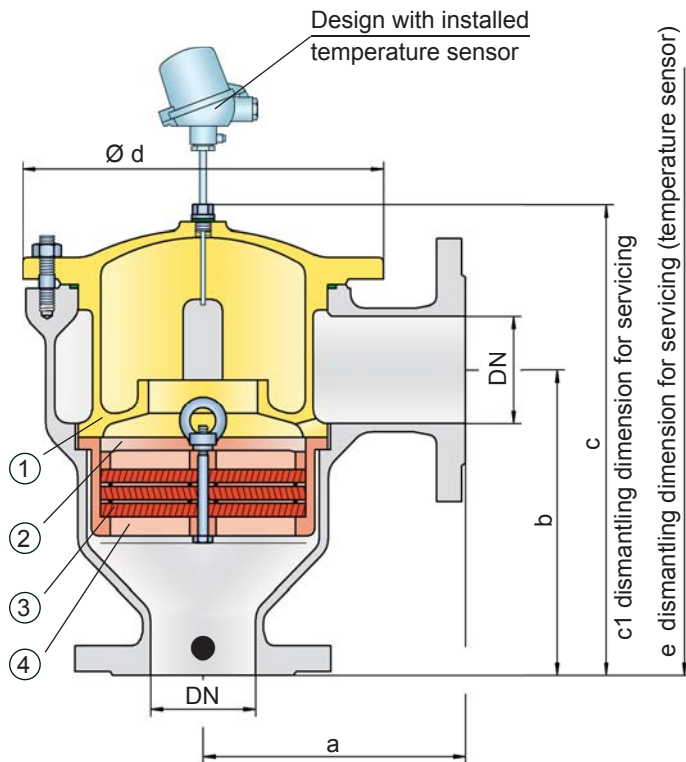

● Connection to the protected side

Function and Description

The PROTEGO® DR/EU series of in-line detonation flame arresters represents a further development of PROTEGO® flame arresters DR/ES used successfully for decades in industry. The device protects against deflagrations, stable and unstable detonations. The classic right angle design offers considerable cost and maintenance advantages in comparison to a straight through design.

Once a detonation enters the flame arrester, energy is absorbed from the detonation shock wave by the integrated shock absorber (1) before the flame is extinguished in the narrow gaps of the FLAMEFILTER® (3).

The PROTEGO® flame arrester unit (2) consists of several FLAMEFILTER® discs and spacers firmly held in the FLAMEFILTER® cage (4). The gap size and number of FLAMEFILTER® discs are determined by the operating data parameters of the mixture flowing in the line (explosion group, pressure, temperature). This device is available explosion groups from IIA to IIB3 (NEC group D to C MESH ≥ 0.65 mm).

The standard design can be used up to an operating temperature of +60°C / 140°F and an absolute operating pressure acc. to table 3. **Numerous special approvals can be obtained for higher temperatures and pressures upon request.**

Type-approved in accordance with the current ATEX Directive and EN ISO 16852 as well as other international standards.

Special Features and Advantages

- minimum number of FLAMEFILTER® discs due to the effective shock absorber
- quick removal and installation of the complete PROTEGO® flame arrester unit and of the FLAMEFILTER® discs in the cage
- modular flame arrester unit enables each individual FLAMEFILTER® discs to be replaced and cleaned
- provides protection from deflagration as well as from stable and unstable detonation
- the right angle design saves pipe elbows
- extended application range for higher operating temperatures and pressures
- minimum pressure loss and hence low operating and lifecycle costs
- cost efficient spare parts

Design Types and Specifications

There are four different designs available:

Basic in-line detonation flame arrester	DR/EU-	<input type="checkbox"/>	<input type="checkbox"/>
In-line detonation flame arrester with integrated temperature sensor* as additional protection against short time burning	DR/EU-	<input type="checkbox"/>	<input type="checkbox"/>
In-line detonation flame arrester with heating jacket	DR/EU-	<input type="checkbox"/>	<input type="checkbox"/>
in-line detonation flame arrester with integrated temperature sensor* and heating jacket	DR/EU-	<input type="checkbox"/>	<input type="checkbox"/>

*Resistance thermometer for device group II, category (1) 2 (GII cat. (1) 2)



Stabilized FLAMEFILTER®
Discs (Flyer pdf)

Table 1: Dimensions

Dimensions in mm / inches

To select the nominal size (DN), please use the flow capacity charts on the following pages

DN	25 / 1"	32 / 1 ¼"	40 / 1 ½"	50 / 2"	65 / 2 ½"	80 / 3"	100 / 4"	125 / 5"	150 / 6"
a	125/4.92	125/4.92	153/6.02	155/6.10	198/7.80	200/7.87	250/9.84	332/13.07	335/13.19
b	140/5.51	140/5.51	183/7.20	185/7.28	223/8.78	225/8.86	290/11.42	357/14.06	360/14.17
c	210/8.27	210/8.27	290/11.42	290/11.42	365/14.37	365/14.37	440/17.32	535/21.06	535/21.06
c1	285/11.22	285/11.22	395/15.55	395/15.55	500/19.69	500/19.69	595/23.43	750/29.53	750/29.53
d	150/5.91	150/5.91	210/8.27	210/8.27	275/10.83	275/10.83	325/12.80	460/18.11	460/18.11
e	495/19.49	495/19.49	600/23.62	600/23.62	705/27.76	705/27.76	795/31.30	950/37.40	950/37.40

Table 2: Selection of the explosion group

MESG	Expl. Gr. (IEC/CEN)	Gas Group (NEC)	Special approvals upon request
> 0,90 mm	IIA	D	
≥ 0,75 mm	IIB2	C	
≥ 0,65 mm	IIB3	C	

Table 3: Selection of max. operating pressure

DN		25 / 1"	32 / 1 ¼"	40 / 1 ½"	50 / 2"	65 / 2 ½"	80 / 3"	100 / 4"	125 / 5"	150 / 6"
Expl. Gr.	IIA P _{max}	1.6 / 23.2	1.6 / 23.2	1.6 / 23.2	1.6 / 23.2	1.6 / 23.2	1.6 / 23.2	1.5 / 21.7	1.2 / 17.4	1.2 / 17.4
	IIB2 P _{max}								1.4 / 20.3	1.4 / 20.3
	IIB3 P _{max}	1.6 / 23.2	1.6 / 23.2	1.6 / 23.2	1.6 / 23.2	1.6 / 23.2	1.6 / 23.2	1.4 / 20.3	1.2 / 17.4*	1.2 / 17.4*

P_{max} = maximum allowable operating pressure in bar / psi (absolute), higher operating pressure upon request

* special flame arrester unit

Table 4: Specification of max. operating temperature

≤ 60°C / 140°F	Tmaximum allowable operating temperature in °C	higher operating temperatures upon request
-	Designation	

Table 5: Material selection for housing

Design	B	C	D	* for devices exposed to elevated temperatures above 150°C / 302°F, gaskets made of PTFE. The housing and cover with the shock absorber can also be delivered in steel with an ECTFE coating.
Housing	Carbon Steel	Stainless Steel	Hastelloy	
Heating jacket (DR/EU-H-(T)-...)	Steel	Stainless Steel	Stainless Steel	
Cover with shock absorber	Steel	Stainless Steel	Hastelloy	
O-Ring	FPM *	PTFE	PTFE	
Flame arrester unit	A	C, D	E	

Special materials upon request

Table 6: Material combinations of the flame arrester unit

Design	A	C	D	E	* the FLAMEFILTER® are also available in the materials Tantalum, Inconel, Copper, etc. when the listed housing and cage materials are used.
FLAMEFILTER® cage	Steel	Stainless Steel	Stainless Steel	Hastelloy	
FLAMEFILTER® *	Stainless Steel	Stainless Steel	Hastelloy	Hastelloy	
Spacer	Stainless Steel	Stainless Steel	Hastelloy	Hastelloy	

Special materials upon request

Table 7: Flange connection type

EN 1092-1; Form B1	other types upon request
ASME B16.5; 150 lbs RFSF	



for safety and environment

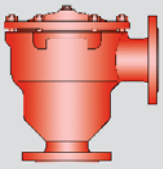

In-Line Detonation Flame Arrester

Flow Capacity Charts

PROTEGO® DR/EU

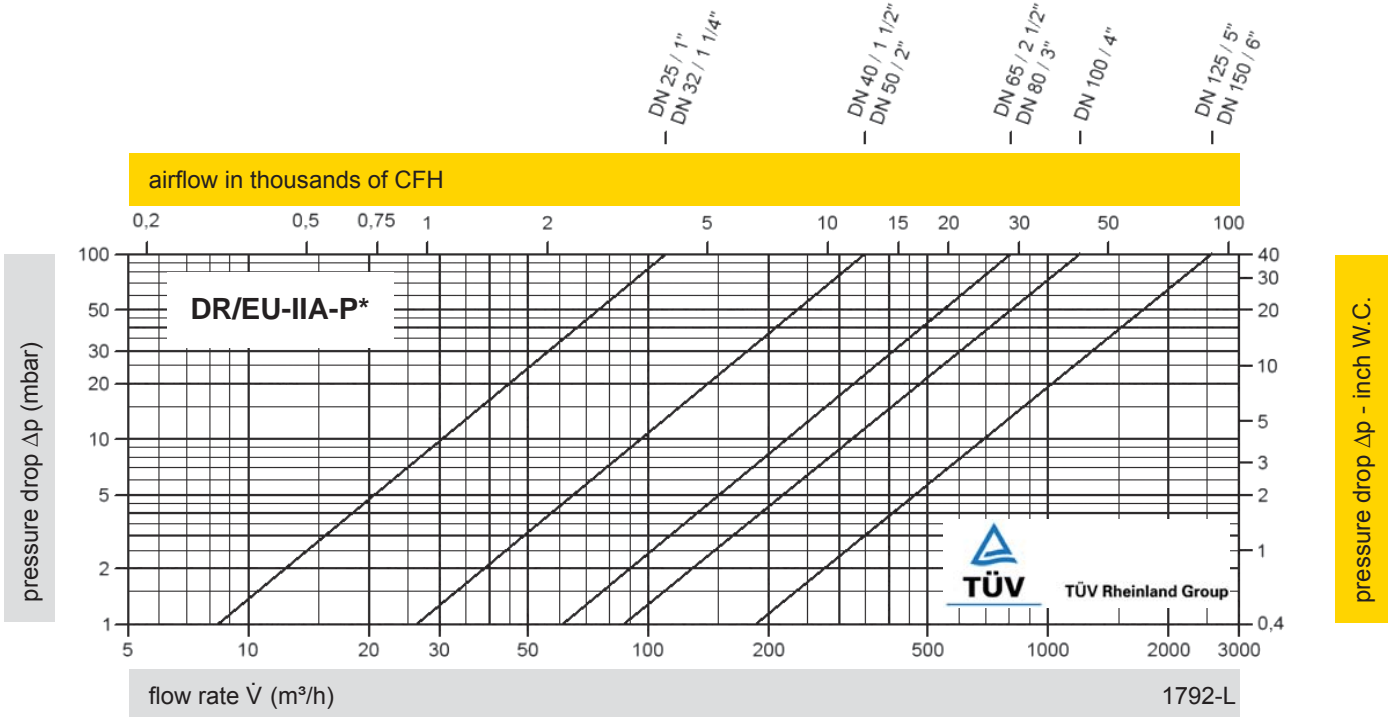

P* see table 3

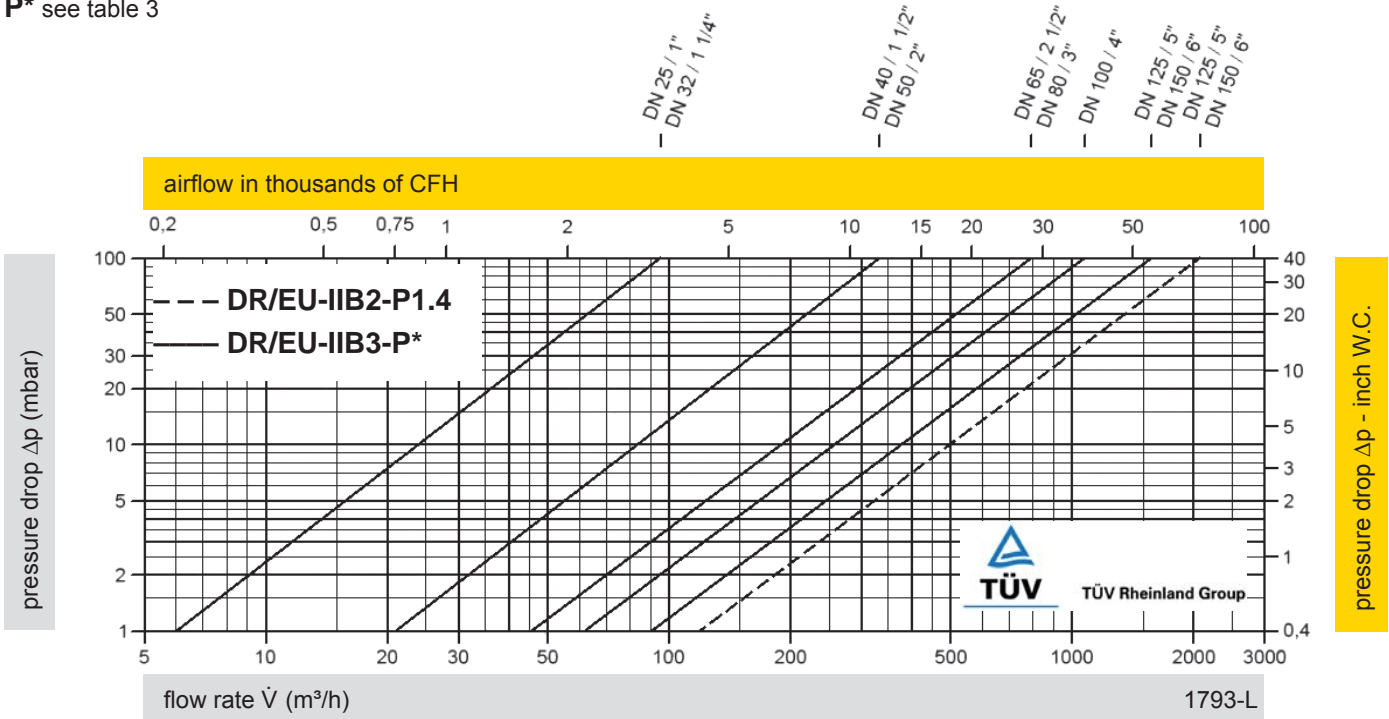

The flow capacity charts have been determined with a calibrated and TÜV certified flow capacity test rig. Volume flow \dot{V} in (m³/h) and CFH refer to the standard reference conditions of air ISO 6358 (20°C, 1bar). Conversion to other densities and temperatures refer to Vol. 1: "Technical Fundamentals".

www.protego.com



for safety and environment

PROTEGO® Pressure/Vacuum Relief Valves

end-of-line



Volume 5

Volume 5



for safety and environment



Function and Description

The function of pressure/vacuum valves for relief and conservation and the corresponding applications is discussed in „Technical Fundamentals“ (→ Vol. 1). In this chapter PROTEGO®'s product line of pressure/vacuum relief valves in end-of-line application is presented.

These are special devices that function as an **end-of-line valve** to protect against pressure and vacuum. The valves may be designed as pipe away version which can be connected to a vent header to process vapors.

Pressure relief valves prevent vapor loss up to the adjusted set pressure and offer reliable protection against excess pressure.

Vacuum relief valves prevent the unallowable entrance of air up to the adjusted set pressure and offer reliable protection against vacuum.

Pressure/vacuum relief valves perform all of the above tasks.

PROTEGO® pressure/vacuum disc relief valves have weight-loaded or spring-loaded valve pallets.

PROTEGO® pressure/vacuum relief valves with a full-lift disc discharge the volumetric flow within 10% overpressure from the set pressure up to full lift. After the response, the valve pallet immediately transitions to a full lift (Figs. 1 and 2).

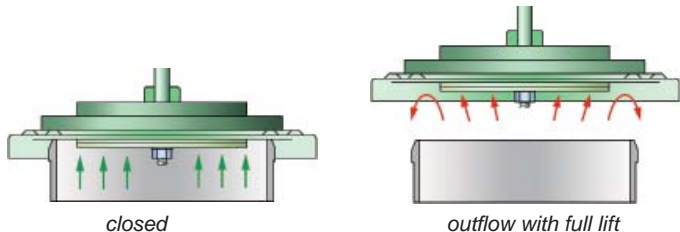

Fig. 1: Outflow with a full-lift disc and air cushion seal

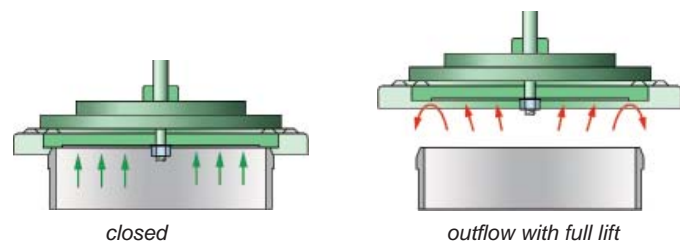

Fig. 2: Outflow with a full-lift disc and metal seal

This is attained by precisely harmonizing the diameter and height of the valve pallet rim with the adapted, lapped valve seat. In addition, a flow-enhancing design reinforces the overall effect on the outflow side. These valve pallets are used in end-of-line valves and in-line valves. The arrangement of valve pallet guidance and seal is combined in the term valve pallet.

Given the right size, the unique **10% technology** of the valves enables a set pressure that is just 10% below the maximum allowable tank pressure. For tanks with emergency relief vents the opening pressure of the relief valve needs to be below the set pressure of the emergency relief vent. The valve immediately opens to a full lift under a full load like a classic safety valve but in response to minimum changes in pressure. The full-lift discs are the result

of years of development. The ingenious engineering enables reliable valve pallet operation at a full load. The highly developed PROTEGO® manufacturing technology has produced a seal that is far superior to the conventional standard. This feature is supported by valve seats made of high-quality stainless steel and individually lapped valve pallets or valve seats with an air cushion seal, among other things.

Diaphragm valves are pressure/vacuum relief valves with a flexible diaphragm. Their special design is to satisfactorily handle problem products, even at extremely low temperatures below freezing, a thousand times over.

Special features and advantages

- Large flows with only a slight pressure drop
- Pressure setting close to the opening pressure (PROTEGO® 10% technology) for optimum retention of pressure in the system
- Seal superior to the normal standard values, which minimizes product loss
- The valve pallet is guided within the housing to protect against the weather

Preferred Applications

PROTEGO® pressure/vacuum relief valves are used as inbreathing and outbreathing valves, pressure relief valves, conservation valves, for simple control, and for venting tanks and equipment when an unallowable vacuum or pressure is exceeded. They are used for low pressures, e.g. in pressure ranges in which classic safety valves cannot be used due to their limited performance characteristics. PROTEGO® valves are available as pressure relief valves, vacuum relief valves, or as combined pressure/vacuum relief valves.

PROTEGO® **diaphragm valves** are used for problem products and low temperatures.

Pilot valves are advantageous for special control responses or when a tight seal is required up to the point at which the valve starts to open (-> Volume 9).

High-velocity-vent valves are used **on tanker ships and for special land uses.**

Installation and servicing

The valves come with detailed installation and servicing instructions.

Shipping braces are installed for safe transportation. Make sure that the transportation locks are removed before installing the valves. Startup checklists help to properly set up the valves for use.

Selection and sizing

To operate the system properly, the right valve is to be selected.

The criteria for selecting the right device are:

Function – a pressure relief valve, a vacuum relief valve, or a combined pressure/vacuum relief valve, with a pipe-away connection if needed.

Design – a combined end-of-line valve or separate pressure relief and vacuum relief valves with a perpendicular connection or horizontal connection. The devices are weight-loaded; therefore the valves are to be installed vertically.

The adjusted set pressure – the standard maximum allowable (tank) pressure minus 10% overpressure; it determines the combination of materials for the disc.

Type of seal – for disc valves according to the pressure level, either with an air cushion seal, or with a metal seal to provide an extremely tight seal.

Special operating conditions – for viscous and adhesive media, for frost-protected operation, or for use with polymerizing products.

The **nominal diameter** of the valve is generally determined by the connecting flange of the pipe, tank, or system part, or by the design specified in the performance diagram. To size a valve, the flow must be known for the overpressure output (outbreathing) and vacuum output (inbreathing). The nominal diameter or number of valves may have to be adjusted. Take into account potential system counterpressure when connecting a pipe.

Sizing

The **valve size** results from the volume flow which has to be vented to avoid an increase above the maximum allowable pressure or vacuum. Certified volume flow diagrams are used for sizing. For correct sizing the operating conditions and the pressure drops of the piping system (including other installed devices) and superimposed backpressures have to be taken into account.

Detailed procedures and examples for sizing are described in "Technical Fundamentals" (see Volume 1).

Example 1

Given: Volume flow \dot{V}_{max} in m³/h / CFH (e.g. for in- or outbreathing of a storage tank this is the sum of the pump capacity and the thermal breathing requirement) and maximum allowable opening pressure (e.g. tank pressure) p_T in mbar / inch W.C.

Requested: Valve size DN

Procedure: The intersection point of \dot{V}_{max} and p_T determines the required valve size. Opening pressure = the maximum allowable tank pressure. The volume flow diagrams show the volume flow as function of the opening pressure for a fully open valve.

The set pressure of the valve has to be determined so that the calculated volume flow can safely be discharged. For a valve

which needs 10% overpressure to reach full lift the set pressure may be chosen 10% below the fully open pressure (e.g. maximum allowable tank pressure). Attention: pressure drop of piping systems and other installed devices have to be considered!

Many conventional valves need 100% overpressure to reach full lift. In these cases the set pressure may be just half of the maximum allowable tank pressure. Consequently these valves open earlier and avoidable product losses occur.

Example 2

Alternatively the valve performance has to be checked if the size and maximum allowable pressure are provided.

Given: Connection nozzle size and maximum allowable opening pressure (e.g. tank pressure) p in mbar / inch W.C.

Required: Volume flow in m³/h / CFH, set pressure p_A in mbar / inch W.C.

Procedure: From the intersection point of the straight line of p and the valve performance curve of the specific valve size the volume flow \dot{V}_{max} is determined. The volume flow of the set pressure p_A may be 10%, (PROTEGO® technology) or 40% or 100% below the opening pressure p_T . Attention: pressure drop of piping systems and other installed devices have to be considered!

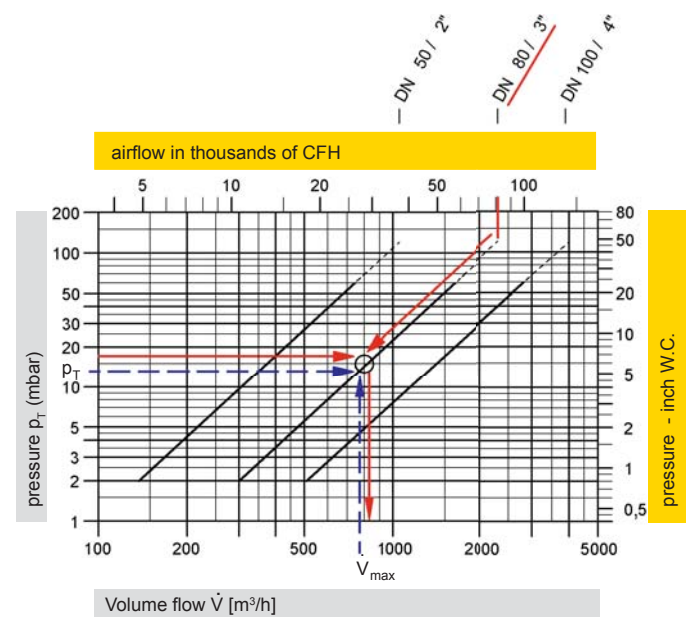

The required set pressure (= start of opening) will be the opening pressure (valve fully open) minus the characteristic overpressure.

For PROTEGO® valves and end of line devices the overpressure characteristic is 10% unless otherwise stated. Within 10% overpressure the valve pallet will reach full lift. A further increase in flow performance will follow the pressure volume flow diagram.







Material selection is based on plant and engineering specifications.



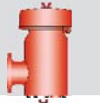

PROTEGO® Pressure/Vacuum-Relief-Valves - end-of-line

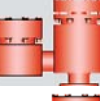
Image	Type	Size	pressure setting		Design O = horizontal connection X = vertical connection	O = soft sealing X = metallic sealing	O = for non-standard operating parameters	O = for critical Medium (Polymerisation, Corrosion, Crystallisation)	O = Heating jacket, Heating coil	Page
			positive setting range mbar / inch W.C.	negative setting range mbar / inch W.C.						
Pressure Relief Valves, weight pallet type										
	P/EL	50 - 80 2" - 3"	+3.5 up to +210/ +1.4 up to +84		X	O / X			O	176 - 177
	P/ELR	80 - 100 3" - 4"	+3.5 up to +210/ +1.4 up to +84		X	O / X			O	178 - 179
	SD/BS-H	80-200 3" - 8"	+5 up to +210/ +2 up to +84		X	X	O		O	180 - 181
	D/SVL	50-300 2" - 12"	+2.0 up to +60/ +0.8 up to +24		X	O / X				182 - 183
	ER-V-LP	200-700 8" - 28"	+3.4 up to +15/ +1.36 up to +6		X	O			O	184 - 185
	ER/V	200-700 8" - 28"	DN 200-350: +5 up to +40/ +2 up to +16 DN 400-700: +5 up to +25/ +2 up to +10		X	O			O	
	ER/VH	200-700 8" - 28"	DN 200-350: >+40 up to +60/ >+16 up to +24 DN 400-700: >+25 up to +60/ >+10 up to +24		X	O				186 - 187
	ER/V-F	200-700 8" - 28"	>+60 up to +500/ >+24 up to +200		X	O				188 - 189
	D/KSM	50-200 2" - 8"	+5.0 up to +100/ +2.0 up to +40		X	O	O	O		190 - 191
Vacuum Relief Valves, weight pallet type										
	SV/E-1-0	50 - 300 2" - 12"		-2.0 up to -60 / -0.8 up to -24	O	O / X			O	192 - 193
	SV/T-0-H	80 - 250 3" - 10"		-7.0 up to -50 / -2.8 up to -20	X	X	O		O	194 - 196
	V/KSM	50-200 2" - 8"		-5.0 up to -100 / -2.0 up to -40	O	O	O	O		198 - 199
	V/SV	40 - 300 1½" - 12"		-2.0 up to -60 / -0.8 up to -24	X	O / X			O	NEW

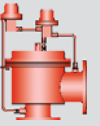
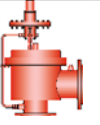
	Type	Size	pressure setting		Design O = horizontal connection X = vertical connection	O = soft sealing X = metallic sealing	O = for non-standard operating parameters	O = for critical Medium (Polymerisation, Corrosion, Crystallisation)	O = Heating jacket, Heating coil	Page
			positive setting range mbar / inch W.C.	negative setting range mbar / inch W.C.						
Pressure and Vacuum Relief Valves, weight pallet type										
	PV/EL	50 - 80 2" - 3"	+2.0 up to +210/ +0.8 up to +84	-3.5 up to -35 / -1.4 up to -14	O	O / X			O	200 - 202
	PV/ELR	80 - 100 3" - 4"	+2.0 up to +210/ +0.8 up to +84	-3.5 up to -50 / -1.4 up to -20	O	O / X			O	204 - 206
	VD/SV	40 - 300 1½" - 12"	+2.0 up to +60 / +0.8 up to +24	-2.0 up to -60 / -0.8 up to -24	X	O / X			O	208 - 210
	VD/SV-PA(L)	50 - 300 2" - 12"	+2.0 up to +60 / +0.8 up to +24	-2.0 up to -60 / -0.8 up to -24	X	O / X			O	212 - 215
	VD/KSM	50 - 200 2" - 8"	+5.0 up to +100 / +2.0 up to +40	-5.0 up to -100 / -2.0 up to -40	X	O	O	O		216 - 218
	VD/KSM-PA	50 - 200 2" - 8"	+5.0 up to +100 / +2.0 up to +40	-5.0 up to -100 / -2.0 up to -40	X	O	O	O		220 - 222
Pressure and Vacuum Relief Valves, pilot-operated										
	PM(D)S		→ Volume 9	NEW						408 - 411
	PM-HF		→ Volume 9	NEW						412 - 415

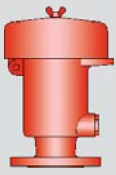

Pressure Relief Valve



PROTEGO® P/EL

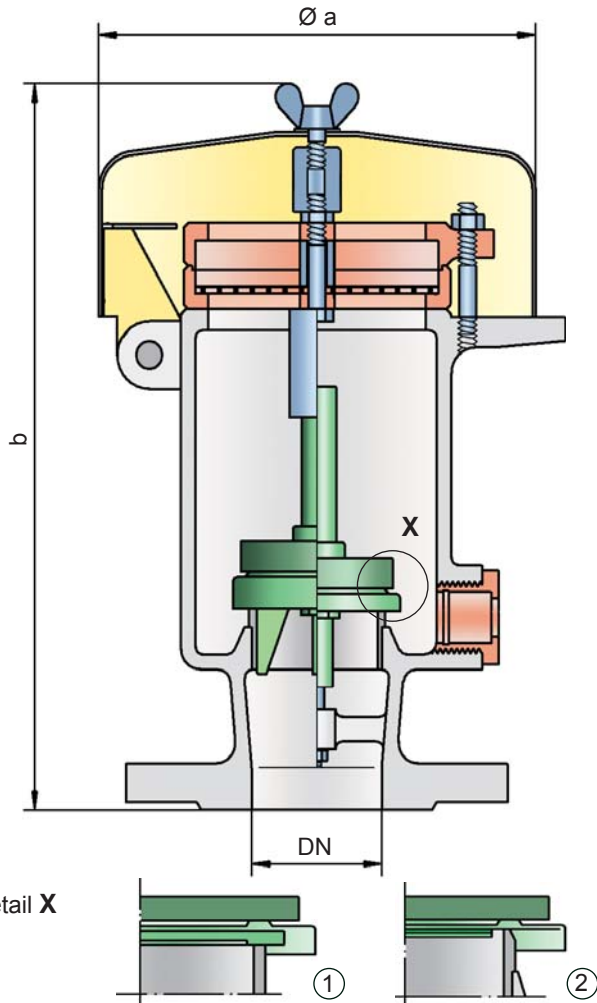

lowed PROTEGO® to develop a low pressure valve which has the same opening characteristic as a high pressure safety relief valve. This “full lift type” technology allows the valve to be set just 10% below the maximum allowable working pressure of the tank and still safely vent the required mass flow.

Due to our highly developed manufacturing technology the tank pressure is maintained up to set pressure, with a tightness that is far superior to the conventional standard. This feature is achieved by valve seats made of high quality stainless steel and with precisely lapped valve pallets (1) or with an air cushion seal (2) in conjunction with high quality FEP diaphragm. The valve pallets are also available with a PTFE seal to prevent the valve pallets from sticking when sticky products are used, and they enable the use of corrosive media. After the excess pressure is discharged, the valve reseats and provides a tight seal.

The optimized fluid dynamic design of the valve body and valve pallet is a result of many years of research work, which allow a stable operation of the valve pallet and optimized performance resulting in reduction of product losses.

Special Features and Advantages

- “full lift type” technology valve utilizes only 10% overpressure to reach full lift
- extreme tightness and hence least possible product losses and reduced environmental pollution
- the set pressure is close to the opening pressure which results in best possible pressure management of the system
- high flow capacity
- the valve pallet is guided within the housing to protect against harsh weather conditions
- can be used in areas subject to an explosion hazard
- self-actuated condensate drain

Design Types and Specifications

The valve pallet is weight-loaded. At set pressures greater than 80 mbar (32.1 inch W.C.), an elongated construction is used.

There are two different designs:

Pressure valve in basic design P/EL -

Pressure valve with heating jacket P/EL -

Additional special devices available upon request

Pressure settings:

+3.5 mbar up to +210 mbar
 +1.4 inch W.C. up to +84 inch W.C.
 Higher pressure settings upon request.

Function and Description

The P/EL type PROTEGO® valve is a highly developed pressure relief valve. It is primarily used as a safety device for relieving pressure in tanks, containers and process engineering equipment. The valve protect against unallowable overpressure and prevents the unacceptable loss of product vapors close to the set pressure.

The device will start to open as soon as the set pressure is reached and only requires 10% overpressure to full lift. Continuous investments into research and development have al-



Vents - 10% Technology
(Flyer pdf)



Leak Rate/10% Technology
(Flyer pdf)



The optimised valve pallet
(Flyer pdf)

Table 1: Dimensions

Dimensions in mm / inches

To select the nominal size (DN), use the flow capacity chart on the following page

DN	50 / 2"	50 / 2"	80 / 3"	80 / 3"
Set pressure	≤ +80 mbar ≤ +32.1 inch W.C.	> +80 mbar > +32.1 inch W.C.	≤ +80 mbar ≤ +32.1 inch W.C.	> +80 mbar > +32.1 inch W.C.
a	218 / 8.58	218 / 8.58	218 / 8.58	218 / 8.58
b	287 / 11.30	452 / 17.80	289 / 11.38	454 / 17.87

Dimensions for pressure valves with heating jacket upon request

Table 2: Material selection for housing

Design	B	C	Special materials upon request
Housing	Steel	Stainless Steel	
Heating jacket (P/EL-H-...)	Steel	Stainless Steel	
Valve seat	Stainless Steel	Stainless Steel	
Weather hood	Steel	Stainless Steel	
Protective mesh screen	Stainless Steel	Stainless Steel	

Table 3: Material selection for pressure valve pallet

Design	A	B	C	D	Special materials (Aluminum-coated, Titanium, Hastelloy) and higher pressure settings upon request
Pressure range (mbar)	+3.5 up to +5.0	>+5.0 up to +14	>+14 up to +210	>+14 up to +210	
(inch W.C.)	+1.4 up to +2.0	>+1.4 up to +5.6	>+5.6 up to +84	>+5.6 up to +84	
Valve pallet	Aluminium	Stainless Steel	Stainless Steel	Stainless Steel	
Sealing	FEP	FEP	Metal to Metal	PTFE	

Table 4: Flange connection type

EN 1092-1; Form B1	other types upon request
ASME B16.5; 150 lbs RFSF	

Flow Capacity Chart

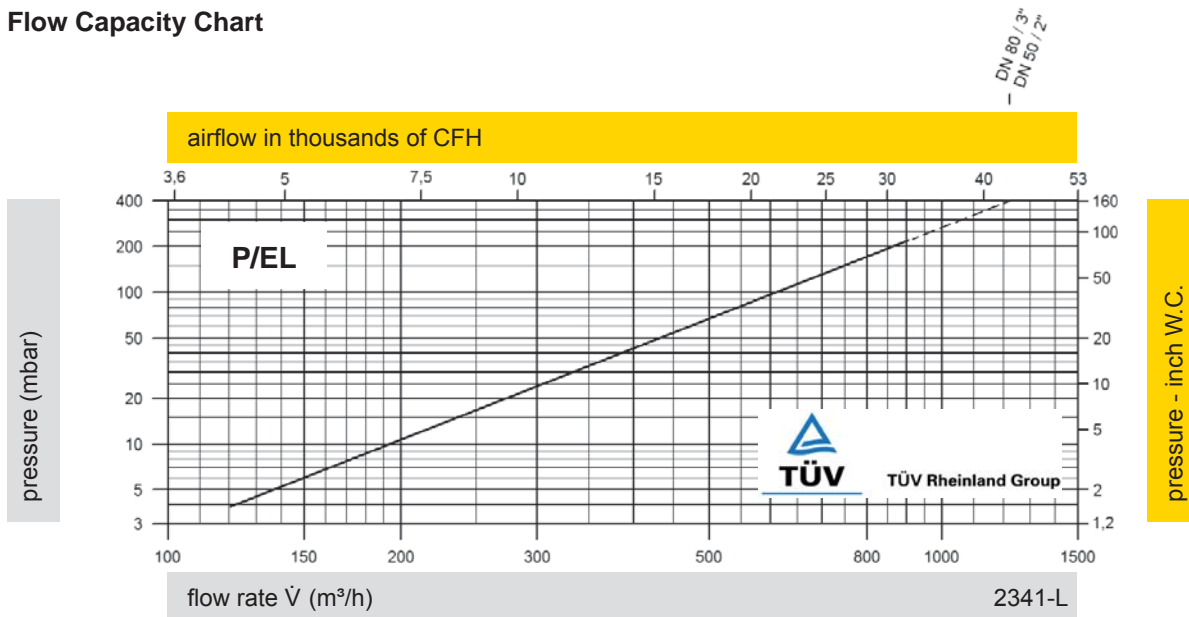

The flow capacity curve has been determined with a calibrated and TÜV certified flow capacity test rig. Volume flow \dot{V} in (m³/h) and CFH refer to the standard reference conditions of air ISO 6358 (20°C, 1bar). Conversion to other densities and temperatures refer to Vol. 1: "Technical Fundamentals".



Pressure Relief Valve



PROTEGO® P/ELR

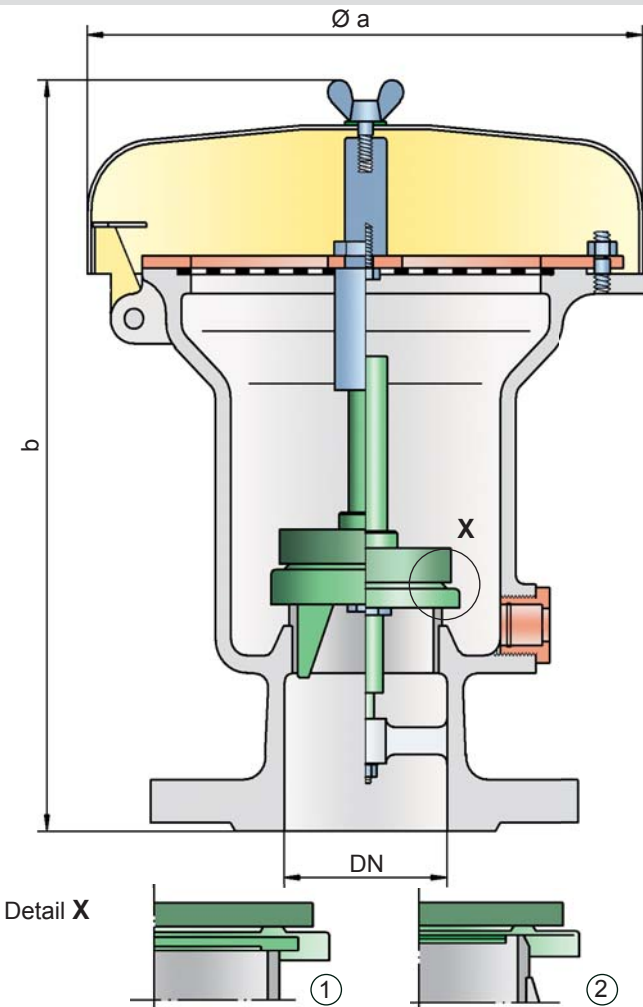

lowed PROTEGO® to develop a low pressure valve which has the same opening characteristic as a high pressure safety relief valve. This “full lift type” technology allows the valve to be set just 10% below the maximum allowable working pressure of the tank and still safely vent the required mass flow.

Due to our highly developed manufacturing technology the tank pressure is maintained up to set pressure with a tightness that is far superior to the conventional standard. This feature is achieved by valve seats made of high quality stainless steel and with precisely lapped valve pallets (1) or with an air cushion seal (2) in conjunction with high quality FEP diaphragm. The valve pallets are also available with a PTFE seal to prevent the valve pallets from sticking when sticky products are used and to enable the use of corrosive fluids. After the excess pressure is discharged, the valve reseats and provides a tight seal.

The optimized fluid dynamic design of the valve body and valve pallet is a result of many years of research work, which allow a stable operation of the valve pallet and optimized performance resulting in reduction of product losses.

Special Features and Advantages

- “full lift type” technology valve utilizes only 10% overpressure to reach full lift
- extreme tightness and hence least possible product losses and reduced environmental pollution
- the set pressure is close to the opening pressure which results in best possible pressure management of the system
- high flow capacity
- the valve pallet is guided within the housing to protect against harsh weather conditions
- Can be used in areas subject to an explosion hazard
- self-actuated condensate drain

Design Types and Specifications

The valve pallet is weight-loaded. At set pressures greater than 80 mbar (32.1 inch W.C.), an elongated construction is used.

There are two different designs:

Pressure valve in basic design

P/ELR -

Pressure valve with heating jacket

P/ELR - H

Additional special devices available upon request

Pressure settings:

+3.5 mbar up to +210 mbar
 +1.4 inch W.C. up to +84 inch W.C.
 Higher pressure settings upon request.

Function and Description

The P/ELR type PROTEGO® valve is a highly developed pressure relief valve with excellent flow performance. It is primarily used as a safety device for relieving pressure in tanks, containers, and process engineering equipment. The valve offers reliable protection against overpressure and prevents the unacceptable loss of product vapors close to the set pressure.

The device will start to open as soon as the set pressure is reached and only requires 10% overpressure to full lift. Continuous investments into research and development have al-



Vents - 10% Technology
(Flyer pdf)



Leak Rate/10% Technology
(Flyer pdf)



The optimised valve pallet
(Flyer pdf)

Table 1: Dimensions

Dimensions in mm / inches

To select the nominal size (DN), use the flow capacity chart on the following page

DN	80 / 3"	80 / 3"	100 / 4"	100 / 4"
Set pressure	≤ +80 mbar ≤ +32.1 inch W.C.	> +80 mbar > +32.1 inch W.C.	≤ +80 mbar ≤ +32.1 inch W.C.	> +80 mbar > +32.1 inch W.C.
a	353 / 13.90	353 / 13.90	353 / 13.90	353 / 13.90
b	345 / 13.58	505 / 19.88	345 / 13.58	505 / 19.88

Dimensions for pressure valves with heating jacket upon request

Table 2: Material selection for housing

Design	B	C	Special materials upon request
Housing	Steel	Stainless Steel	
Heating jacket (P/ELR-H-...)	Steel	Stainless Steel	
Valve seat	Stainless Steel	Stainless Steel	
Weather hood	Steel	Stainless Steel	
Protective mesh screen	Stainless Steel	Stainless Steel	

Table 3: Material selection for pressure valve pallet

Design	A	B	C	D	Special materials (Aluminum-coated, Titanium, Hastelloy) and higher pressure settings upon request
Pressure range (mbar) (inch W.C.)	+3.5 up to +5.0 +1.4 up to +2.0	>+5.0 up to +14 >+1.4 up to +5.6	>+14 up to +210 >+5.6 up to +84	>+14 up to +210 >+5.6 up to +84	
Valve pallet	Aluminium	Stainless steel	Stainless steel	Stainless steel	
Sealing	FEP	FEP	Metal to Metal	PTFE	

Table 4: Flange connection type

EN 1092-1; Form B1	other types upon request
ASME B16.5; 150 lbs RFSF	

Flow Capacity Chart

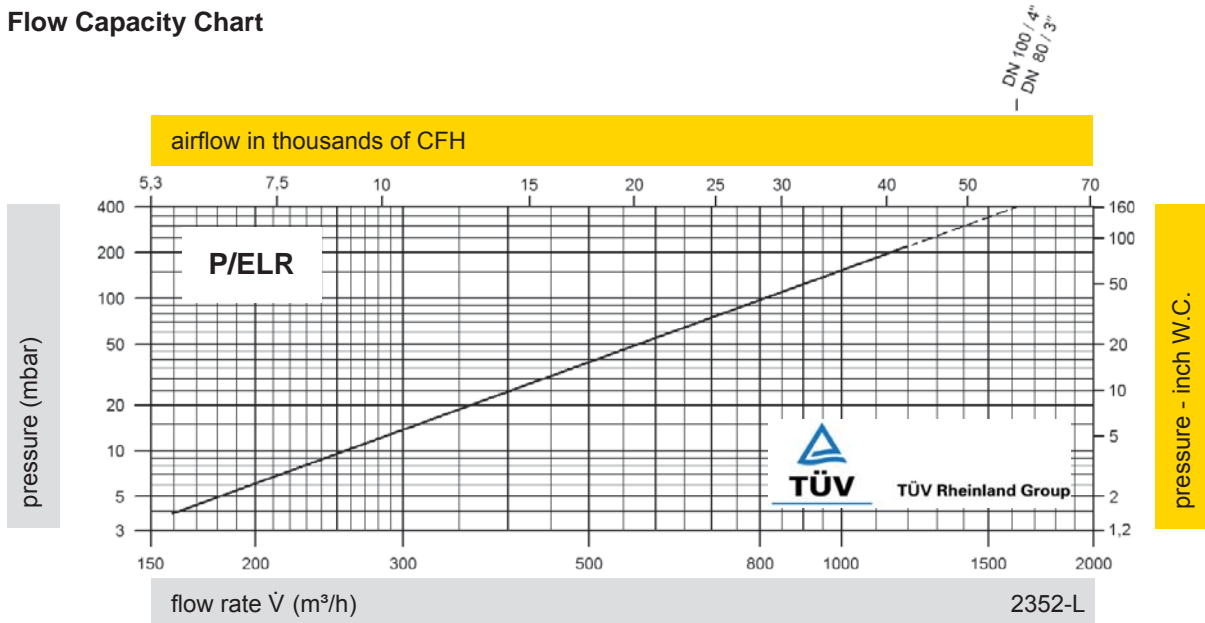

The flow capacity chart has been determined with a calibrated and TÜV certified flow capacity test rig. Volume flow \dot{V} in (m^3/h) and CFH refer to the standard reference conditions of air ISO 6358 (20°C, 1bar). Conversion to other densities and temperatures refer to Vol. 1: "Technical Fundamentals".

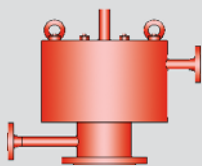

Pressure Relief Valve in heat jacketed design

PROTEGO® SD/BS-H

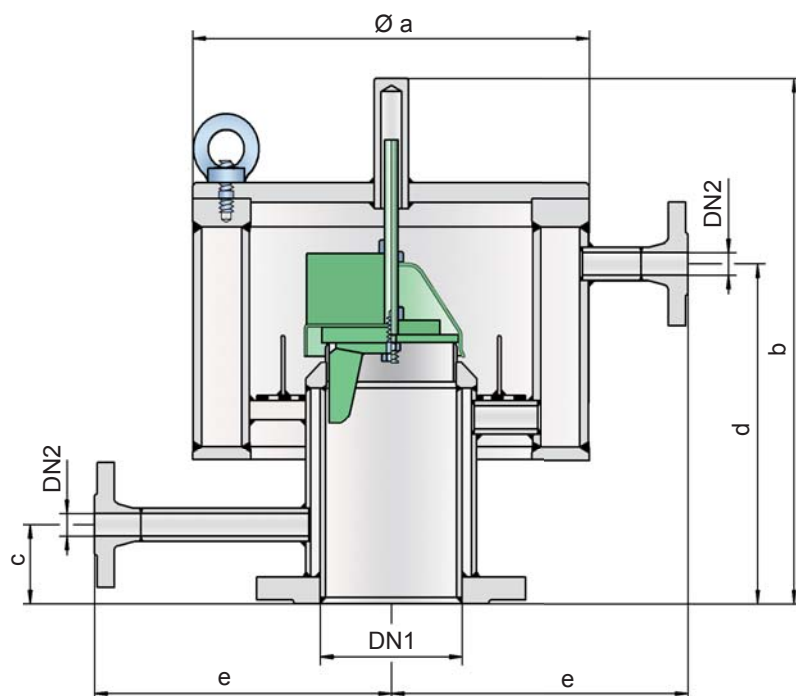

Pressure Settings:

+5.0 mbar up to +210 mbar
 +2.0 inch W.C. up to +84 inch W.C.
 Higher pressure settings upon request.

Function and Description

The SD/BS-H type PROTEGO® valve is a highly developed pressure relief valve with a heating jacket down to the flange. It is primarily used as pressure relief device for vessels and process engineering equipment under difficult operating conditions. This includes extreme weather conditions or products that tend to form polymers at certain temperatures, adhere, or form deposits that negatively influence function (such as bitumen, tar, dust). The valve offers reliable protection against overpressure and prevents the unacceptable loss of product vapors close to the set pressure.

The device will start to open as soon as the set pressure is reached and only requires 10% overpressure to full lift. Continuous investments into research and development have allowed PROTEGO® to develop a low pressure valve which has the same opening characteristic as a high pressure safety relief valve. This "full lift type" technology allows the valve to be set just 10% below the maximum allowable working pressure of the tank and still safely vent the required mass flow.

Due to our highly developed manufacturing technology the tank pressure is maintained up to set pressure, with a tightness that is far superior to the conventional standard. This feature is achieved by valve seats made of high-grade stainless steel with precisely lapped valve pallets and a reinforced housing design. After the excess pressure is discharged, the valve reseats and provides a tight seal again.

Special Features and Advantages

- "full lift type" technology valve utilizes only 10% overpressure to reach full lift
- extreme tightness and hence least possible product losses and reduced environmental pollution
- set pressure is close to the opening pressure which results in best possible pressure management of the system
- high flow capacity
- the valve pallet is guided within the housing to protect against harsh weather conditions
- can be used in areas subject to an explosion hazard
- heating jacketed design down to the flange to avoid cold bridges
- maximum permissible heating medium temperature of 320°C / 608°F (at 6 bar / 87 psi)
- a special design with a heatable valve cover is available
- at low pressure settings, an optimized valve pallet cover prevents the set pressure from being distorted by dust or condensate
- reinforced housing design
- a special design with a mechanical vent pallet lift device is available

Design Types and Specifications

The valve pallet is weight-loaded. Starting at a set pressure of 30 mbar, a vane guide is also used.

Pressure valve in basic design with heating jacket **SD/BS - H**

Additional special devices available upon request

Table 1: Dimensions

Dimensions in mm / inches

To select the nominal size (DN), use the flow capacity chart on the following page

DN1	DN2	a	b		c	d		e
			≤ 30 mbar ≤ 12 inch W.C.	> 30 mbar > 12 inch W.C.		≤ 30 mbar ≤ 12 inch W.C.	> 30 mbar > 12 inch W.C.	
80 / 3" *	15 / ½"	325 / 12.80	400 / 15.75	515 / 20.28	70 / 2.76	250 / 9.84	390 / 15.35	250 / 9.84
100 / 4"	15 / ½"	325 / 12.80	400 / 15.75	505 / 19.88	60 / 2.36	250 / 9.84	380 / 14.96	250 / 9.84
150 / 6"	15 / ½"	405 / 15.94	460 / 18.11	595 / 23.43	60 / 2.36	315 / 12.40	470 / 18.50	290 / 11.42
200 / 8"	15 / ½"	510 / 20.08	470 / 18.50	575 / 22.64	65 / 2.56	305 / 12.01	445 / 17.52	340 / 13.39

* also available with special flange DN 50 / 2"



Vents - 10% Technology
(Flyer pdf)



Leak Rate/10% Technology
(Flyer pdf)

Table 2: Material selection for housing

Design	A	B	Special materials upon request
Housing	Steel	Stainless Steel	
Heating Jacket	Steel	Stainless Steel	
Valve Seat	Stainless Steel	Stainless Steel	

Table 3: Material selection for pressure valve pallet

Design	A	B	C	Special materials and higher pressure settings upon request
Pressure range (mbar) (inch W.C.)	+5 up to +25 +2 up to +10	>+10 up to +30 >+4 up to +12	>+30 up to +210 >+12 up to +84	
Valve pallet	Aluminium	Stainless Steel	Stainless Steel	
Valve pallet hood	Stainless Steel	Stainless Steel	-	
Sealing	Metal to Metal	Metal to Metal	Metal to Metal	

Table 4: Flange connection type

EN 1092-1; Form B1	other types upon request
ASME B16.5; 150 lbs RFSF	

Flow Capacity Chart

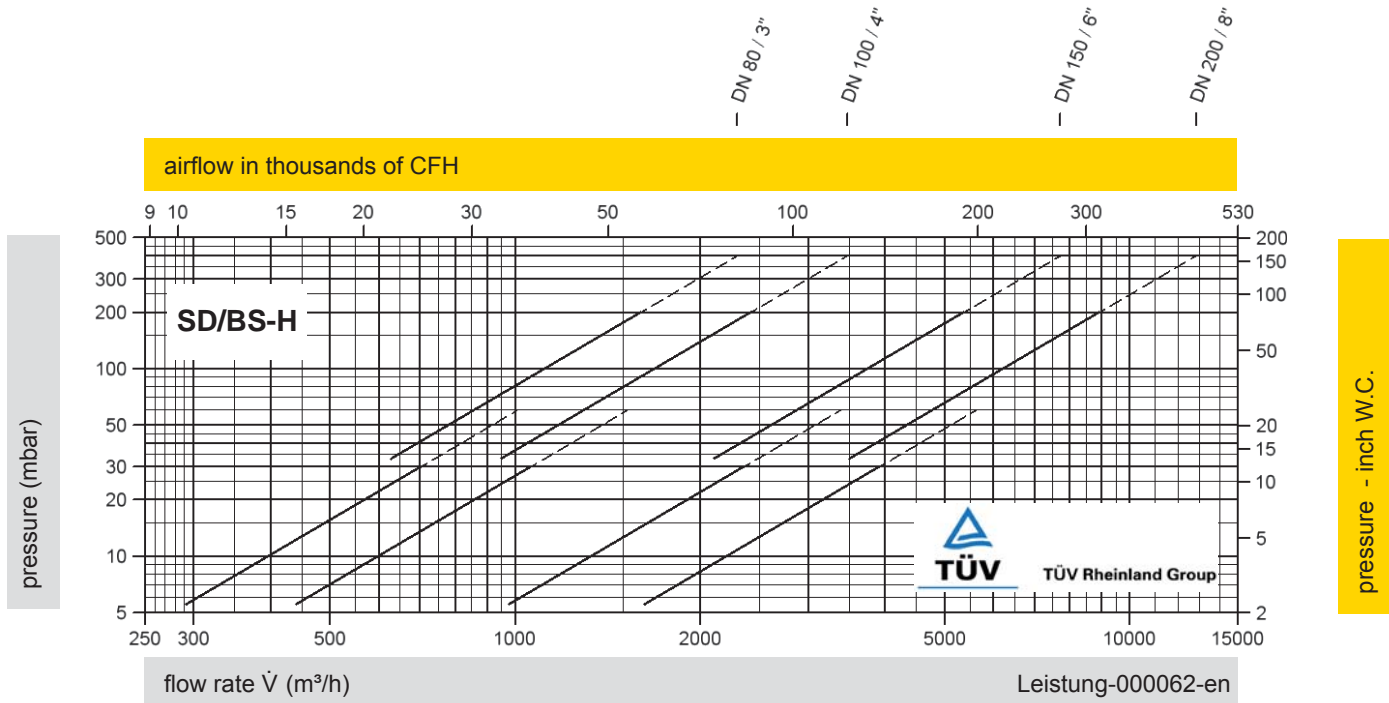

The flow capacity chart has been determined with a calibrated and TÜV certified flow capacity test rig. Volume flow \dot{V} in (m^3/h) and CFH refer to the standard reference conditions of air ISO 6358 (20°C, 1bar). Conversion to other densities and temperatures refer to Vol. 1: "Technical Fundamentals".



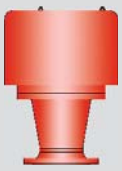

Pressure Relief Valve



PROTEGO® D/SVL

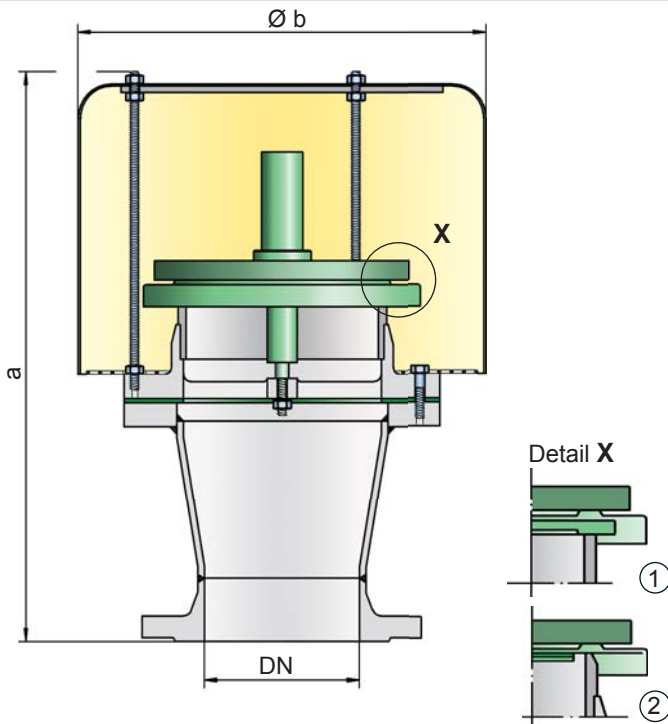

the same opening characteristic as a high pressure safety relief valve. This “full lift type” technology allows the valve to be set just 10% below the maximum allowable working pressure of the tank and still safely vent the required mass flow.

Due to the highly developed manufacturing technology, the tank pressure is maintained up to the set pressure, with a tightness that is far superior to the conventional standard. This feature is achieved by valve seats made of high quality stainless steel and with precisely lapped valve pallets (1) or with an air cushion seal (2) in conjunction with high quality FEP diaphragm. The valve pallets are also available with a PTFE seal to prevent the valve pallet from sticking when sticky products are used, and they enable the use of corrosive media. After the excess pressure is discharged, the valve reseats and provides a tight seal again.

The optimized fluid dynamic design of the valve body and valve pallet is a result of many years of research work, which allow a stable operation of the valve pallet and optimized performance resulting in reduction of product losses.

Special Features and Advantages

- “full lift type” technology valve utilizes only 10% overpressure to reach full lift
- extreme tightness and hence least possible product losses and reduced environmental pollution
- the set pressure is close to the opening pressure which results in best possible pressure management of the system
- extremely high flow capacity
- the valve pallet is guided within the housing to protect against harsh weather conditions
- can be used in areas subject to an explosion hazard

Design Types and Specifications

The valve pallet is weight-loaded. Higher pressures can be achieved upon request with a special spring-loaded design.

Pressure valve in basic design

D/SVL -

Additional special devices available upon request

Pressure settings:

+2.0 mbar up to +60 mbar
 +0.8 inch W.C. up to +24 inch W.C.
 Higher pressure settings upon request.

Function and Description

The D/SVL type PROTEGO® valve is a high performance pressure relief valve. It is primarily used as a safety device for relieving pressure in tanks, containers, and process engineering equipment. The valve offers reliable protection against overpressure and prevents the unacceptable loss of product vapors close to the set pressure.

The device will start to open as soon as the set pressure is reached and only requires 10% overpressure to full lift. Continuous investments into research and development have allowed PROTEGO® to develop a low pressure valve which has

Table 1: Dimensions

Dimensions in mm / inches

To select the nominal size (DN), use the flow capacity chart on the following page

DN	50 / 2"	80 / 3"	100 / 4"	150 / 6"	200 / 8"	250 / 10"	300 / 12"
a	336 / 13.23	412 / 16.22	444 / 17.48	564 / 22.20	664 / 26.20	687 / 27.05	687 / 27.05
b	200 / 7.87	295 / 11.61	295 / 11.61	465 / 18.31	550 / 21.65	650 / 25.59	650 / 25.59



Vents - 10% Technology
(Flyer pdf)



Leak Rate/10% Technology
(Flyer pdf)



The optimised valve pallet
(Flyer pdf)

Table 2: Material selection for housing

Design	A	B	Special Materials upon request
Housing	Steel	Stainless Steel	
Valve seat	Stainless Steel	Stainless Steel	
Sealing	PTFE	PTFE	
Weather hood	Stainless Steel	Stainless Steel	

Table 3: Material selection for pressure valve pallet

Design	A	B	C	D	E	F
Pressure (mbar)	+2.0 up to +3.5	>+3.5 up to +14	>+14 up to +35	>+35 up to +60	>+14 up to +35	>+35 up to +60
range (inch W.C.)	+0.8 up to +1.4	>+1.4 up to +5.6	>+5.6 up to +14	>+14 up to +24	>+5.6 up to +14	>+14 up to +24
Valve	Aluminium	Stainless steel	Stainless steel	Stainless steel	Stainless steel	Stainless steel
Sealing	FEP	FEP	Metal to Metal	Metal to Metal	PTFE	PTFE

Special Materials and higher pressure settings upon request

Table 4: Flange connection type

EN 1092-1; Form B1	other types upon request
ASME B16.5; 150 lbs RF5F	

Flow Capacity Chart

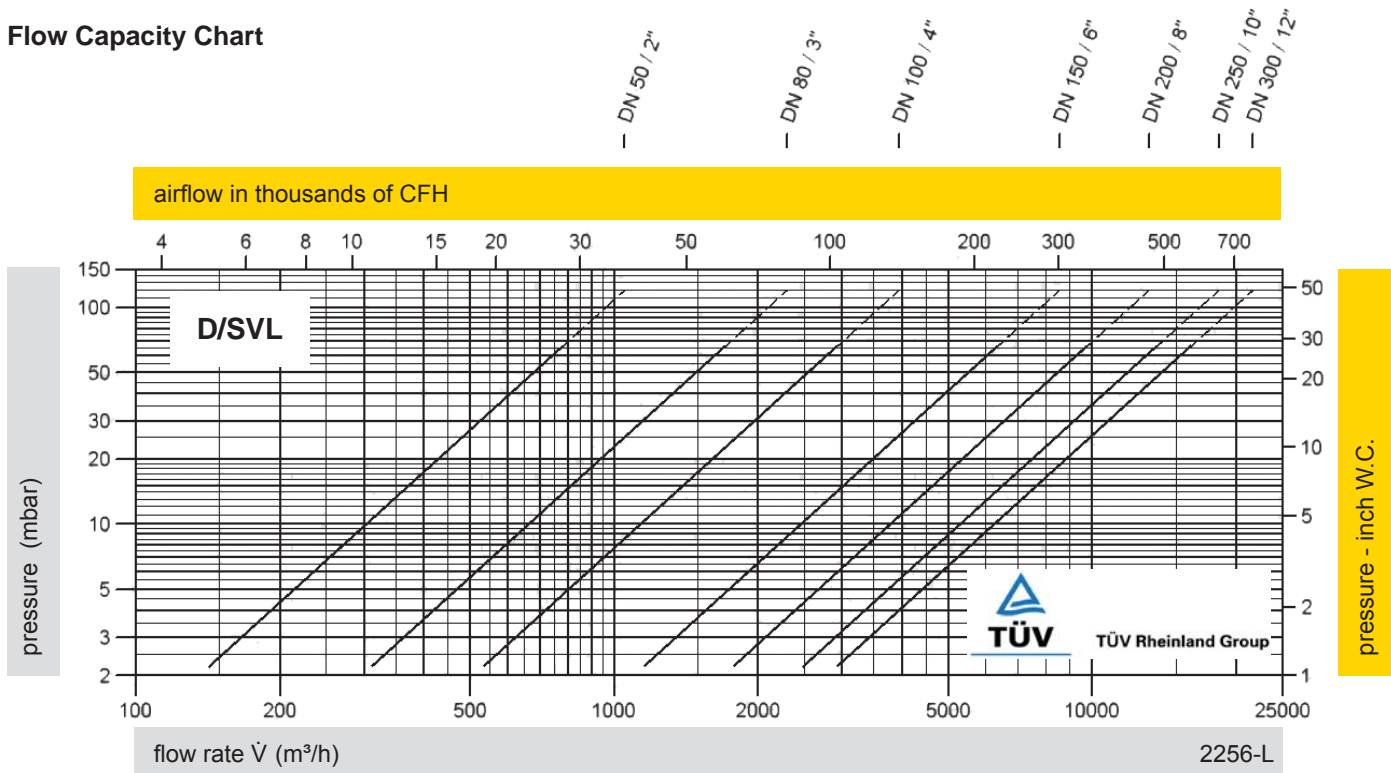

The flow capacity chart has been determined with a calibrated and TÜV certified flow capacity test rig. Volume flow \dot{V} in (m³/h) and CFH refer to the standard reference conditions of air ISO 6358 (20°C, 1bar). Conversion to other densities and temperatures refer to Vol. 1: "Technical Fundamentals".



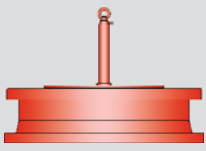

Emergency pressure relief valve

PROTEGO® ER-V-LP

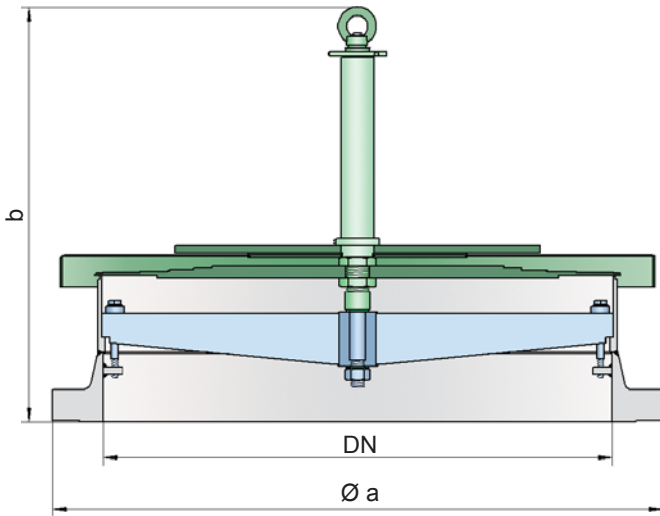

Pressure Settings:

+3.4 mbar up to +15 mbar
+1.4 inch W.C. up to +6 inch W.C.

For higher pressure settings, see types ER/V, ER/VH and ER/V-F.

Function and Description

The PROTEGO® Type ER-V-LP valve is a sophisticated pressure relief valve for applications in which a high flow efficiency is of the essence. It is primarily used as an emergency pressure relief valve on storage tanks, vessels, silos, and process engineering equipment; it offers reliable protection against excessive overpressure and prevents excessive product loss at pressures as high as close to the set-to-operate pressure. It is designed to relieve particularly large quantities to prevent the vessel rupturing in an emergency case.

The valve will start to open as soon as the set-to-operate pressure is reached and only requires a 10% pressure increase or opening pressure differential until full lift. Dedicated R & D investments have enabled PROTEGO® to develop a new *valve pallet technology* for which a patent has been granted. This patented *valve pallet technology* allows the area characteristic typical of safety valves to be also applied to lower-pressure applications, while ensuring that minimum leakage-rate requirements are met.

Adopting this new patented *valve pallet technology* permits the valve to be set to just 10% below the maximum allowable working pressure of the tank and still vent the required mass flow.

Due to the sophisticated manufacturing technology, the tank pressure is maintained up to the set-to-operate pressure, with seal-tight requirements far above common standards being met. Once the excess pressure is relieved, the valve reseats and seals tight again.

Special Features and Advantages

- patented *valve pallet technology* guarantees that minimum leakage-rate requirements can be met and, hence, least possible product losses and reduced impact on the environment are ensured
- 10% Technology for minimum pressure increase until full lift
- set-to-operate pressure close to the opening pressure; hence, best possible pressure management of the system
- high flow efficiency
- valve pallet is guided within a closed system and, thus, protected from atmospheric influence
- suited for use in hazardous areas
- rugged body design
- movable components are secured
- best technology for API tanks

Design Types and Specifications

The valve pallet is weight-loaded. Higher set-to-operate pressures are achieved with Types ER/V and ER/VH (lever-operated) valves or Type ER/V-F (spring-loaded) valves.

Pressure valve in basic design

ER-V-LP

Additional special devices available upon request



Emergency Relief Valve
(Flyer pdf)



Vents - 10% Technology
(Flyer pdf)

Table 1: Dimensions

Dimensions in mm / inches

To select the nominal size (DN), use the flow capacity chart on the following page

DN	200 / 8"	250 / 10"	300 / 12"	350 / 14"	400 / 16"	450 / 18"	500 / 20"	600 / 24"	700 / 28"
a	343 / 13.50	406 / 15.98	483 / 19.02	533 / 20.98	597 / 23.50	635 / 25.00	699 / 27.52	813 / 32.01	837 / 32.95
b	378 / 14.88	399 / 15.71	409 / 16.10	440 / 17.32	455 / 17.91	464 / 18.27	481 / 18.94	556 / 21.89	571 / 22.48

Table 2: Material selection

Design	A	B	Special Materials upon request
Housing	Steel	Stainless Steel	
Valve seat	Stainless Steel	Stainless Steel	
Valve pallet	Stainless Steel	Stainless Steel	
Sealing	Stainless Steel	Stainless Steel	

Table 3: Flange connection type

EN 1092-1; Form B1	other types upon request
ASME B16.5; 150 lbs RFSF	

Flow Capacity Chart

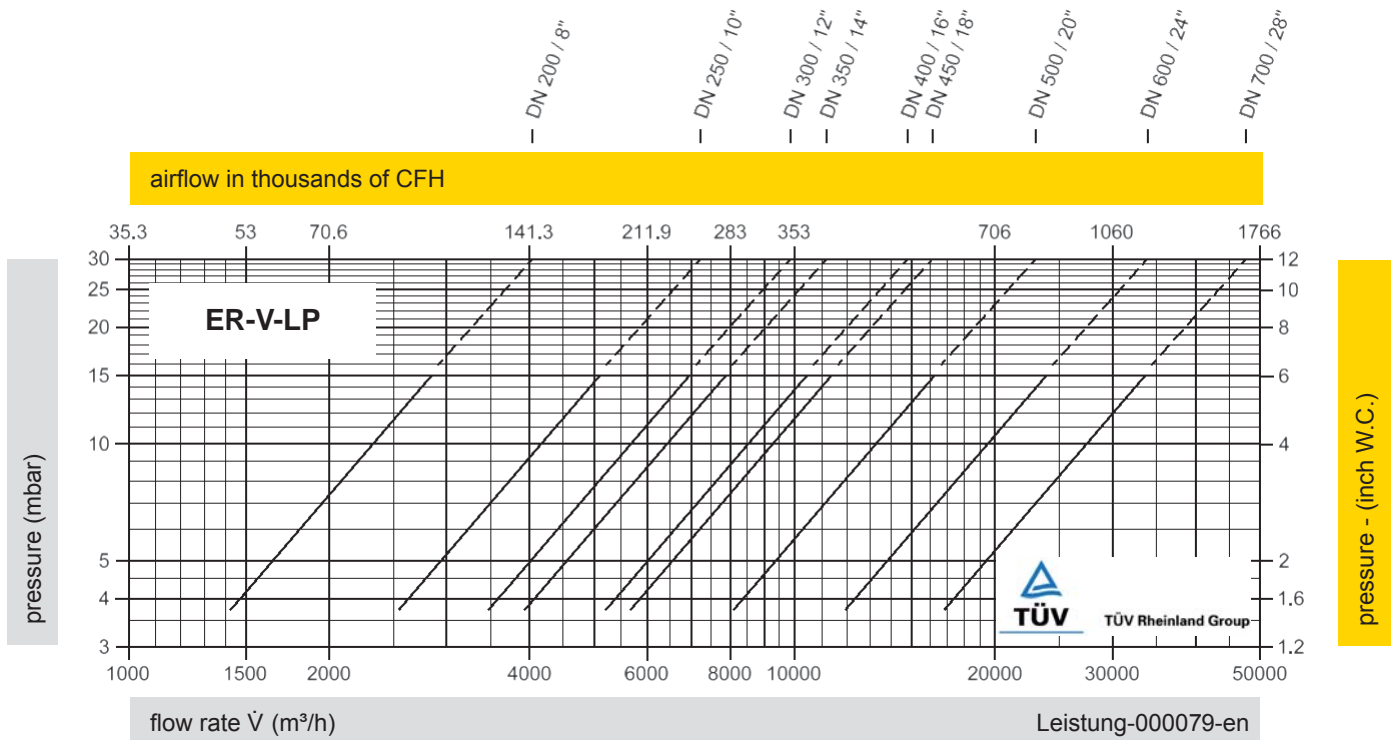

The flow capacity chart has been determined with a calibrated and TÜV certified flow capacity test rig. Volume flow \dot{V} in (m³/h) and CFH refer to the standard reference conditions of air ISO 6358 (20°C, 1bar). Conversion to other densities and temperatures refer to Vol. 1: "Technical Fundamentals".



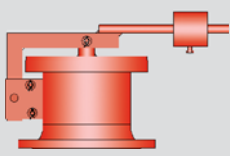

Pressure Relief Valve

PROTEGO® ER/VH

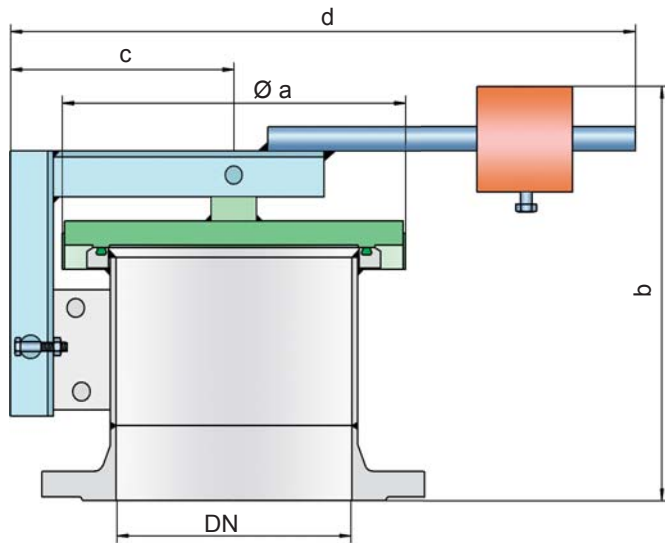

Pressure settings:

DN 200 to DN 350: >+40 mbar up to +60 mbar
>+16 inch W.C. up to +24 inch W.C.
DN 400 to DN 700: >+25 mbar up to +60 mbar
>+10 inch W.C. up to +24 inch W.C.

Higher and lower pressure settings, upon request.

Function and Description

The ER/VH type PROTEGO® valve is a highly developed emergency pressure relief valve with high flow capacity. It is primarily used as a safety device for emergency pressure relief for storage tanks, containers, silos, and process engineering equipment; it offers reliable protection against overpressure and prevents impermissible product vapor loss close to the set pressure. It is designed to discharge particularly large amounts to prevent the vessel from rupturing in an emergency case. Higher set pressures are achieved by a lever with lockable weight loading. The position of the weight is factory-marked. Starting at DN 500, the devices can also be used as manhole covers.

When the set pressure is reached, the valve starts to open and is fully open within 10% overpressure. This unique 10% "full lift type technology" enables a pressure setting that is only 10% below the maximum allowable working pressure or design pres-

sure of the tank. Even in the low pressure range the vent has the opening characteristic comparable to a typical high pressure safety relief valve. The full lift type pallets are a result of many years of development. The valve pallet is mounted on one side.

Due to the highly developed manufacturing technology, the tank pressure is maintained up to the set pressure, with a tightness that is far superior to the conventional standard. This feature is achieved by valve seats made of stainless steel with an inserted O-ring seal, a precisely lapped valve pallet, as well as a reinforced housing design. After the excess pressure is discharged, the valve reseats and provides a tight seal again.

Special Features and Advantages

- "full lift type" technology valve utilizes only 10% overpressure to reach full lift
- excellent tightness and hence least possible product losses and reduced environmental pollution
- the set pressure is close to the opening pressure which results in best possible pressure management of the system
- high flow capacity
- can be used in areas subject to explosion hazards
- reinforced housing design
- safely secured housing cover
- best technology for API-tanks

Design Types and Specifications

The valve pallet is weight-loaded. Lower pressures are generally achieved without a lever design (see ER-V-LP, ER/V), and higher pressures are realized with spring-loading (see ER/V-F).

Pressure valve in basic design

ER/VH

Additional special devices available upon request



Table 1: Dimensions Dimensions in mm / inches

To select the nominal size (DN), use the flow capacity chart on the following page

DN	200 / 8"	250 / 10"	300 / 12"	350 / 14"	400 / 16"	450 / 18"	500 / 20"	600 / 24"	700 / 28"
a	305 / 12.01	375 / 14.76	425 / 16.73	445 / 17.52	495 / 19.49	545 / 21.46	615 / 24.21	715 / 28.15	795 / 31.30
b	350 / 13.78	365 / 14.37	385 / 15.16	390 / 15.35	390 / 15.35	415 / 16.34	430 / 16.93	450 / 17.72	465 / 18.31
c	200 / 7.87	240 / 9.45	265 / 10.43	285 / 11.22	310 / 12.20	330 / 12.99	360 / 14.17	410 / 16.14	450 / 17.72
d	590 / 23.23	735 / 28.94	780 / 30.71	845 / 33.27	890 / 35.04	1070 / 42.13	1090 / 42.91	1140 / 44.88	1380 / 54.33

Table 2: Material selection

Design	A	B
Housing	Steel	Stainless Steel
Valve seat	Stainless Steel	Stainless Steel
Valve pallet	Stainless Steel or Steel-Stainless Steel	Stainless Steel
Sealing	FPM	FPM
Weight	Steel	Stainless Steel

Special materials upon request

Table 3: Flange connection type

EN 1092-1; Form B1	other types upon request
ASME B16.5; 150 lbs RFSF	

Flow Capacity Chart

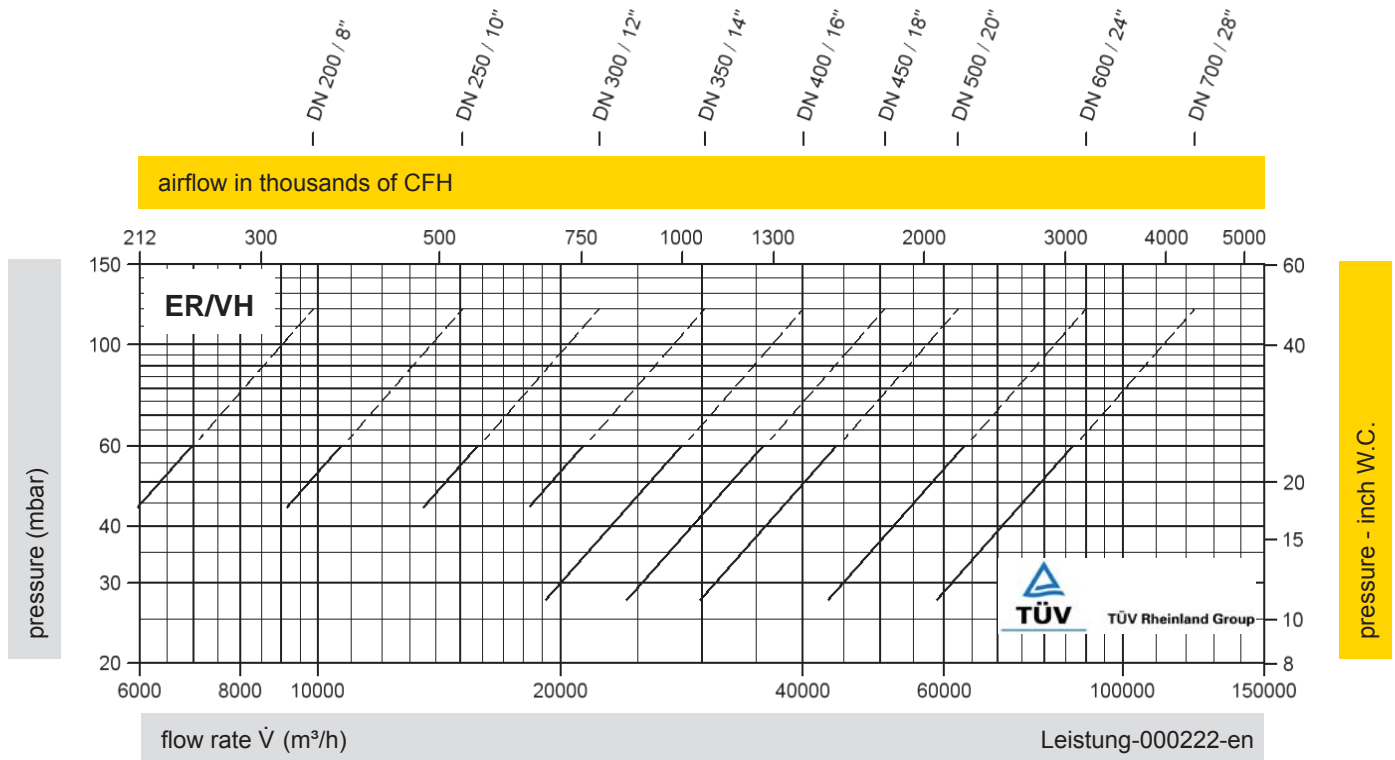

The flow capacity chart has been determined with a calibrated and TÜV certified flow capacity test rig. Volume flow \dot{V} in (m³/h) and CFH refer to the standard reference conditions of air ISO 6358 (20°C, 1bar). Conversion to other densities and temperatures refer to Vol. 1: "Technical Fundamentals".





Pressure Relief Valve

PROTEGO® ER/V-F

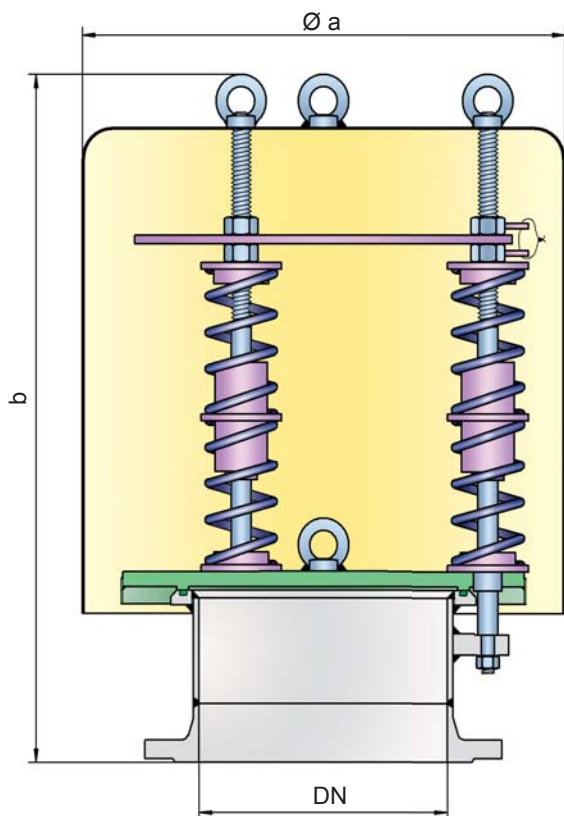

Pressure settings:

>+60 mbar up to +500 mbar

>+24 inch W.C. up to +200 inch W.C.

Higher pressure settings, upon request.

Lower pressure settings, see types ER-V-LP, ER/V and ER/VH.

Function and Description

The ER/V-F type PROTEGO® valve is a highly developed emergency pressure relief valve with high flow capacity. It is primarily used as a safety device for emergency pressure relief for storage tanks, containers, silos, and process engineering equipment; it offers reliable protection against overpressure and prevents impermissible product vapor loss close to the set pressure. It is designed to discharge particularly large amounts to prevent the vessel from rupturing in an emergency case. The spring-loading allows for higher set pressures than those with the ER-V-LP, ER/V or ER/VH.

The device will start to open as soon as the set pressure is reached and only requires 10% overpressure to full lift. Continuous investments into research and development have allowed PROTEGO® to develop a low pressure valve which has the same opening characteristic as a high pressure safety relief valve. This “full lift type” technology allows the valve to be set just 10% below the maximum allowable working pressure of the tank and still safely vent the required mass flow.

Due to the highly developed manufacturing technology, the tank pressure is maintained up to the set pressure, with a tightness that is far superior to the conventional standard. This feature is achieved by valve seats made of high-grade steel with an inserted O-ring seal, a precisely lapped valve pallet, as well as a reinforced housing design. After the excess pressure is relieved, the valve reseats and provides a tight seal again.

Special Features and Advantages

- “full lift type” technology valve utilizes only 10% overpressure to reach full lift
- excellent tightness and hence least possible product losses and reduced environmental pollution
- the set pressure is close to the opening pressure which results in best possible pressure management of the system
- high flow capacity
- the valve pallet is guided within the housing to protect against harsh weather conditions
- can be used in areas subject to explosion hazards
- reinforced housing design
- spring-loading for high set pressures
- best technology for API-tanks

Design Types and Specifications

The valve pallet is spring-loaded. Lower pressures are achieved with the ER-V-LP, ER/V and ER/VH designs.

Pressure valve in basic design

ER/V-F

Additional special devices available upon request



Table 1: Dimensions

Dimensions in mm / inches

To select the nominal size (DN), use the flow capacity chart on the following page

DN	200 / 8"	250 / 10"	300 / 12"	350 / 14"	400 / 16"	450 / 18"	500 / 20"	600 / 24"	700 / 28"
a	465 / 18.31	550 / 21.65	650 / 25.59	650 / 25.59	800 / 31.50	800 / 31.50	1000 / 39.37	1000 / 39.37	1200 / 47.24
b	860 / 33.86 (≤370 mbar ≤148 inchW.C.)	860 / 33.86 (≤240 mbar ≤96 inchW.C.)	1170 / 46.06 (≤240 mbar ≤96 inchW.C.)	1170 / 46.06 (≤270 mbar ≤108 inchW.C.)	1150 / 45.28 (≤220 mbar ≤88 inchW.C.)	1175 / 46.26 (≤170 mbar ≤68 inchW.C.)	1430 / 56.30 (≤130 mbar ≤52 inchW.C.)	1425 / 56.10 (≤140 mbar ≤56 inchW.C.)	1690 / 66.54 (≤140 mbar ≤56 inchW.C.)
b	980 / 38.58 (>370 mbar >148 inchW.C.)	980 / 38.58 (>240 mbar >96 inchW.C.)	1490 / 58.66 (>240 mbar >96 inchW.C.)	1490 / 58.66 (>270 mbar ≤108 inchW.C.)	1490 / 58.66 (>220 mbar ≤88 inchW.C.)	1515 / 59.65 (>170 mbar >68 inchW.C.)	1660 / 65.35 (>130 mbar >52 inchW.C.)	1655 / 65.16 (>140 mbar >56 inchW.C.)	1910 / 75.20 (>140 mbar >56 inchW.C.)

Table 2: Material selection

Design	A	B
Housing	Steel	Stainless Steel
Valve seat	Stainless Steel	Stainless Steel
Valve pallet	Stainless Steel or Steel-Stainless Steel	Stainless Steel
Sealing	FPM	FPM
Pressure spring	Stainless Steel	Stainless Steel
Weather hood	Steel	Stainless Steel

Table 3: Flange connection type

EN 1092-1; Form B1	other types upon request
ASME B16.5; 150 lbs RFSF	

Special materials upon request

Flow Capacity Chart

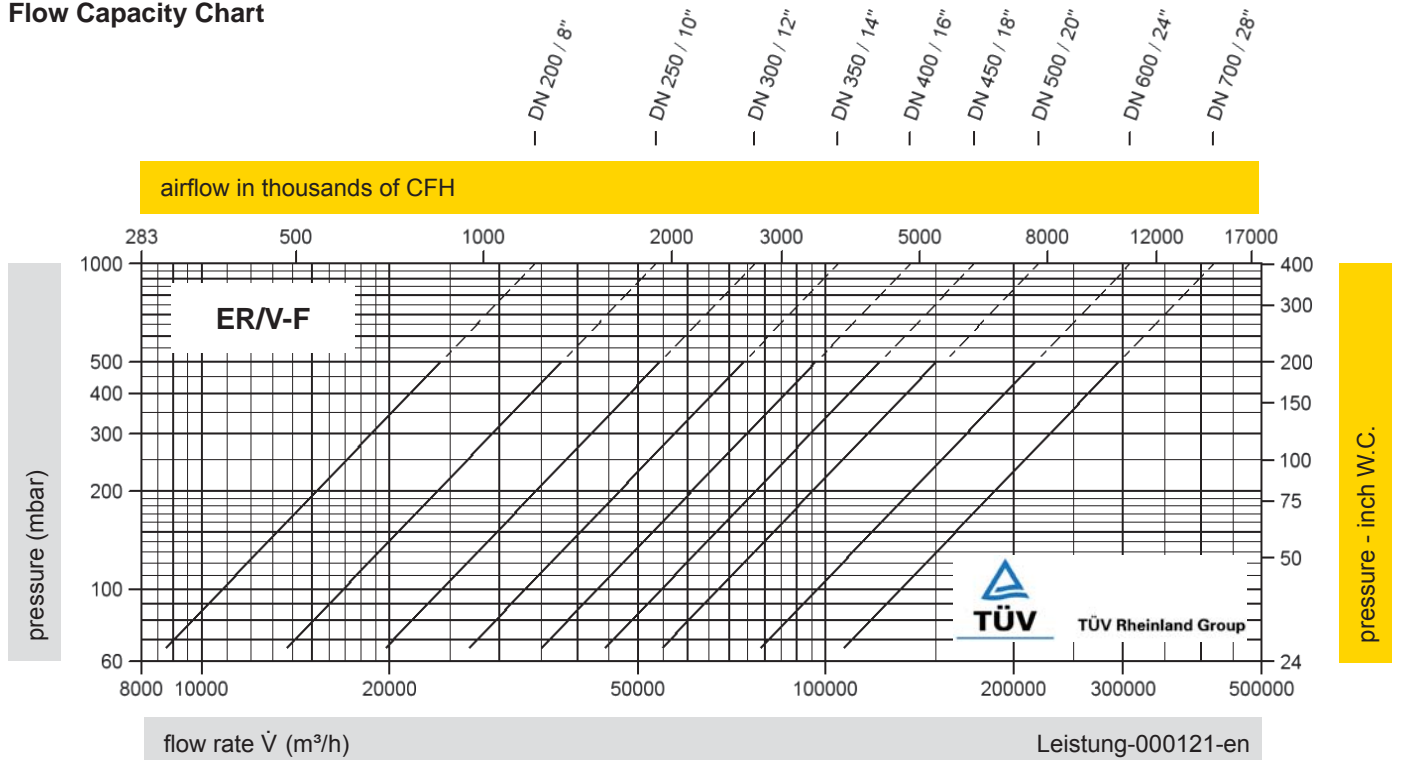

The flow capacity chart has been determined with a calibrated and TÜV certified flow capacity test rig.
Volume flow \dot{V} in (m³/h) and CFH refer to the standard reference conditions of air ISO 6358 (20°C, 1bar).
Conversion to other densities and temperatures refer to Vol. 1: "Technical Fundamentals".



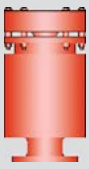

Pressure Relief Valve

made of plastic

PROTEGO® D/KSM

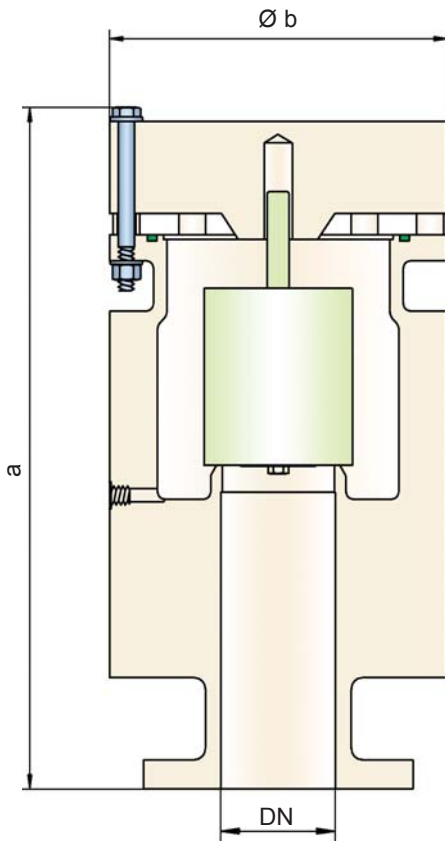

Pressure settings:

- +6.0 mbar up to +100 mbar (DN 50/2")
- +2.4 inch W.C. up to +40 inch W.C.
- +4.0 mbar up to +100 mbar (DN 80/3")
- +1.6 inch W.C. up to +40 inch W.C.
- +4.5 mbar up to +100 mbar (DN 100/4" - DN 200/8")
- +1.8 inch W.C. up to +40 inch W.C.

Higher pressure settings upon request.

Function and Description

The PROTEGO® valve D/KSM is a state-of-the-art pressure relief valve with excellent flow performance made out of highgrade synthetic material. It is primarily used as a safety fitting for relieving pressure in tanks, containers, and process engineering equipment. The valve prevents emission losses almost up to the set pressure. The valve is a perfect solution for corrosive, polymerizing or sticky media.

The device will start to open as soon as the set pressure is reached and only requires 10% overpressure to full lift. Con-

tinuous investments into research and development have allowed PROTEGO® to develop a low pressure valve which has the same opening characteristic as a high pressure safety relief valve. This "full lift type" technology allows the valve to be set just 10% below the maximum allowable working pressure (MAWP) of the tank and still safely vent the required mass flow.

Due to our highly developed manufacturing technology, the tank pressure is maintained up to the set pressure, with a tightness that is far superior to the conventional standard. This feature is facilitated by special valve seats made of high quality synthetic material or PTFE. After the excess pressure is discharged, the valve reseats and provides a tight seal.

The optimized fluid dynamic design of the valve body and valve pallet is a result of many years of research work, which allow a stable operation of the valve pallet and optimized performance resulting in reduction of product losses.

Special Features and Advantages

- "full lift type" technology valve utilizes only 10% overpressure to reach full lift
- extreme tightness and hence least possible product losses and reduced environmental pollution
- the set pressure is close to the opening pressure which results in best possible pressure management of the system
- the valve pallet is guided within the housing to protect against harsh weather conditions
- corrosion resistant valve
- perfect solution for corrosive, polymerizing and sticky media
- weight reduction in comparison to steel/stainless steel
- smooth surface
- condensate drain
- different plastics can be combined
- maintenance friendly design

Design Types and Specifications

The valve pallet is weight-loaded, and the highest pressure levels are only attained with metal disks.

Pressure valve in basic design **D/KSM-**

Additional special devices available upon request

Table 1: Dimensions

Dimensions in mm / inches

To select the nominal size (DN) use the flow capacity charts on the following pages

DN	50 / 2"	80 / 3"	100 / 4"	150 / 6"	200 / 8"
a	376 / 14.80	521 / 20.51	563 / 22.17 (543 / 21.38)*	687 / 27.05 (681 / 26.81)*	952 / 37.48
b	180 / 7.09	250 / 9.84	300 / 11.81	350 / 13.78 (405 / 15.94)*	560 / 22.05 (500 / 19.68)*

* Dimensions in brackets only for PVDF



Vents for corrosive vapor service
(Flyer pdf)



Vents - 10% Technology
(Flyer pdf)



Leak Rate/10% Technology
(Flyer pdf)

Tabelle 2: Material selection for housing

Design	A	B	C
Housing	PE	PP	PVDF
Valve seats	PE	PP	PVDF
Sealing	FPM	FPM	FPM
Valve pallet	A, C, D	B, C, D	C, D

Special materials upon request

Table 3: Material selection for pressure valve pallet

Design	A	B	C	D
Pressure range (mbar) (inch W.C.)	+6.0 up to +16 +2.4 up to +6.4	+5.5 up to +16 +2.2 up to +6.4	+9.5 up to +30 +3.8 up to +12	+30 up to +100 +12 up to +40
Valve pallet	PE	PP	PVDF	Hastelloy
Sealing	PTFE	PTFE	PTFE	PTFE
Spindle guide	PE	PP	PVDF	Hastelloy
Weights	PE	PP	PVDF	Hastelloy

Special materials and other pressure settings are available upon request

Table 4: Flange connection type

EN 1092-1, Form A	other types upon request
ASME B16.5; 150 lbs FF5F	

Flow Capacity Chart

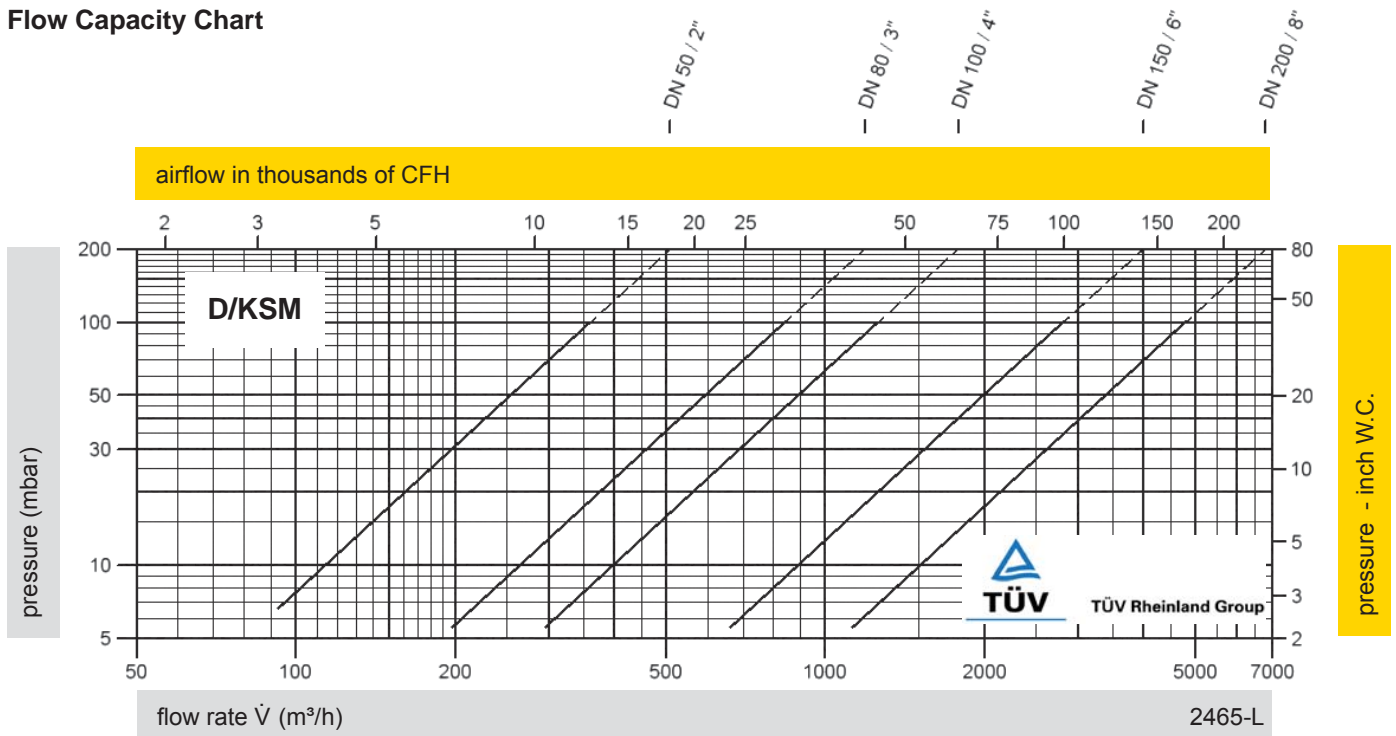

The flow capacity chart has been determined with a calibrated and TÜV certified flow capacity test rig. Volume flow \dot{V} in (m³/h) and CFH refer to the standard reference conditions of air ISO 6358 (20°C, 1bar). Conversion to other densities and temperatures refer to Vol. 1: "Technical Fundamentals".



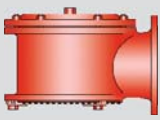

Vacuum Relief Valve



PROTEGO® SV/E-1-0

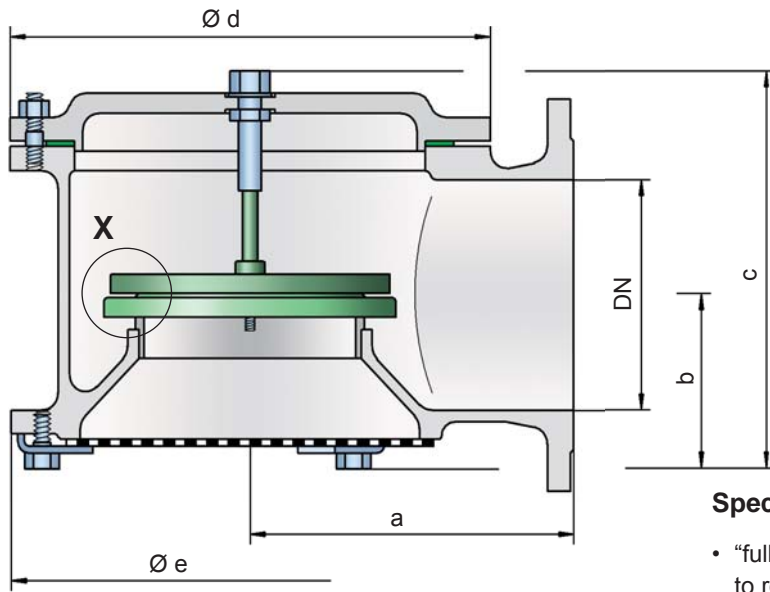

Detail X

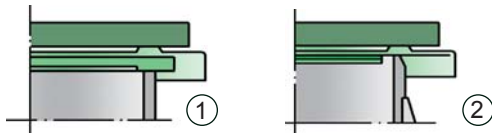

just 10% below the maximum allowable working pressure of the tank and still safely vent the required mass flow.

Due to our highly developed manufacturing technology the tank pressure is maintained up to set pressure, with a tightness that is far superior to the conventional standard. This feature is achieved by valve seats made of high quality stainless steel and with precisely lapped valve pallets (1) or with an air cushion seal (2) in conjunction with high quality FEP diaphragm. The valve pallets are also available with a PTFE seal to prevent the valve pallets from sticking when sticky products are used, and they enable the use of corrosive media. After the vacuum is relieved, the valve reseats and provides a tight seal again.

Special Features and Advantages

- “full lift type” technology valve utilizes only 10% overpressure to reach full lift
- extreme tightness and hence least possible product losses and reduced environmental pollution
- the set pressure is close to the opening pressure which results in best possible pressure management of the system
- high flow capacity
- the valve pallet is guided within the housing to protect against harsh weather conditions
- can be used in areas subject to an explosion hazard
- self-actuated condensate drain
- best technology for API-tanks

Vacuum settings:

-2.0 mbar up to -60 mbar
 -0.8 inch W.C. up to -24 inch W.C.
 Higher vacuum settings upon request.

Function and Description

The SV/E-1-0 type PROTEGO® valve is a highly developed vacuum relief valve with excellent flow performance. It is primarily used as a safety device for relieving vacuum in tanks, containers and process engineering equipment. The valve offers reliable protection against vacuum, and prevents inbreathing of air close to the set pressure.

The device will start to open as soon as the set pressure is reached and only requires 10% overpressure to full lift. Continuous investments into research and development have allowed PROTEGO® to develop a low pressure valve which has the same opening characteristic as a high pressure safety relief valve. This “full lift type” technology allows the valve to be set

Design Types and Specifications

The valve pallet is weight-loaded. Higher vacuum can be achieved upon request with a special spring-loaded design.

There are two different designs:

Vacuum valve in basic design SV/E-1-0 -

Vacuum valve with heating jacket SV/E-1-0 -

Additional special devices available upon request.

Table 1: Dimensions

Dimensions in mm / inches

To select the nominal size (DN) use the flow capacity chart on the following page

DN	50 / 2"	80 / 3"	100 / 4"	150 / 6"	200 / 8"	250 / 10"	300 / 12"
a	140 / 5.51	170 / 6.69	190 / 7.48	230 / 9.06	300 / 11.81	325 / 12.80	425 / 16.73
b	75 / 2.95	85 / 3.35	95 / 3.74	120 / 4.72	140 / 5.51	165 / 6.50	205 / 8.07
c	205 / 8.07	205 / 8.07	285 / 11.22	360 / 14.17	405 / 15.94	460 / 18.11	500 / 19.69
d	170 / 6.69	235 / 9.25	280 / 11.02	335 / 13.19	445 / 17.52	505 / 19.88	505 / 19.88
e	215 / 8.46	215 / 8.46	255 / 10.04	335 / 13.19	425 / 16.73	460 / 18.11	625 / 24.61

Dimensions for vacuum relief valve with heating jacket upon request



Vents - 10% Technology
(Flyer pdf)



Leak Rate/10% Technology
(Flyer pdf)



The optimised valve pallet
(Flyer pdf)

Table 2: Material selection for housing

Design	B	C	D*	
Housing	Steel	Stainless Steel	Aluminium	The housings is also available with an ECTFE-Coating
Heating jacket (SV/E-1-0-H-...)	Steel	Stainless Steel	–	
Valve seat	Stainless Steel	Stainless Steel	Stainless Steel	Special materials upon request
Sealing	PTFE	PTFE	PTFE	

*Design D upon request

Table 3: Material selection for vacuum valve pallet

Design	A	B	C	D	E	F
vacuum range (mbar)	-2.0 up to -3.5	<-3.5 up to -14	<-14 up to -35	<-35 up to -60	<-14 up to -35	<-35 up to -60
(inch W.C.)	-0.8 up to -1.4	<-1.4 up to 5.6	<-5.6 up to -14	<-14 up to -24	<-5.6 up to -14	<-14 up to -24
Valve pallet	Aluminium	Stainless Steel	Stainless Steel	Stainless Steel	Stainless Steel	Stainless Steel
Sealing	FEP	FEP	Metal to Metal	Metal to Metal	PTFE	PTFE

Special materials (Alu-coated, Titanium, Hastelloy) and higher vacuum settings are available upon request

Table 4: Flange connection type

EN 1092-1; Form B1	other types upon request
ASME B16.5; 150 lbs RF5F	

Flow Capacity Chart

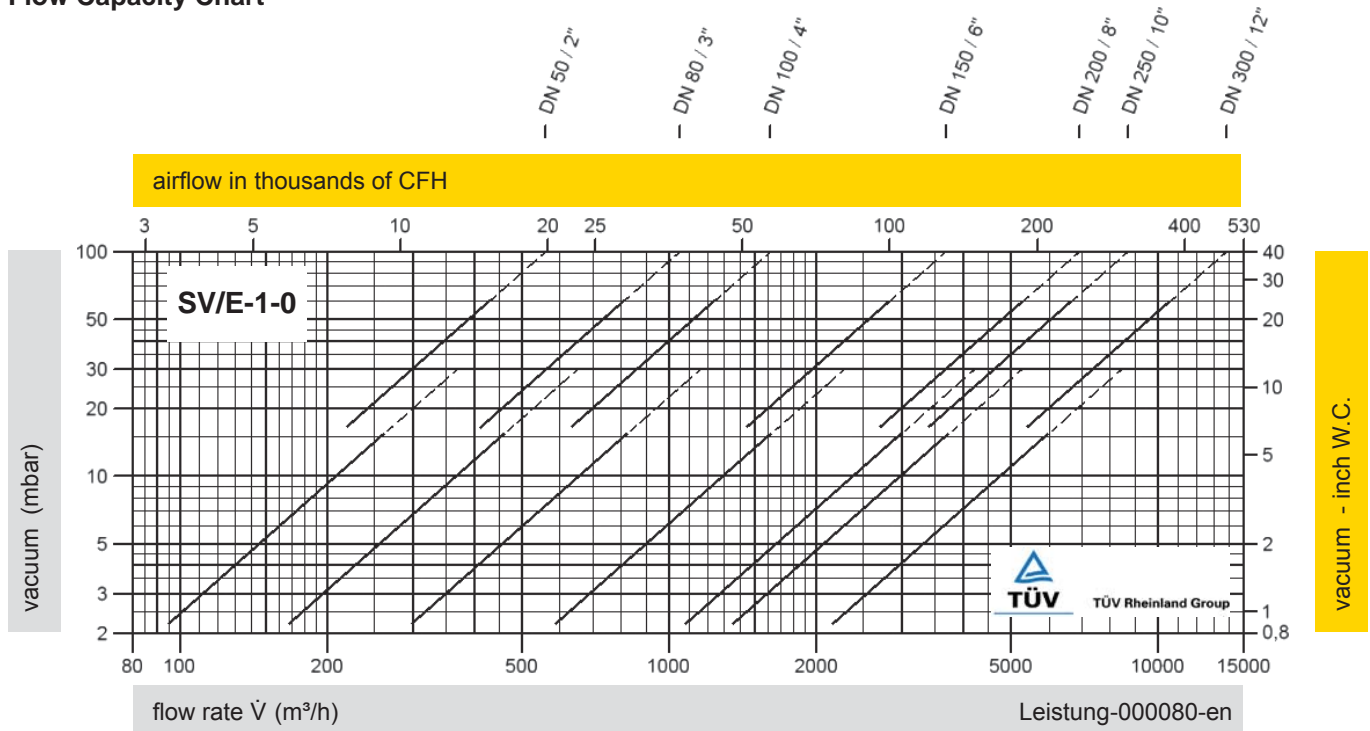

The flow capacity chart has been determined with a calibrated and TÜV certified flow capacity test rig.

Volume flow \dot{V} in (m³/h) and CFH refer to the standard reference conditions of air ISO 6358 (20°C, 1bar).

Conversion to other densities and temperatures refer to Vol. 1: "Technical Fundamentals".



for safety and environment

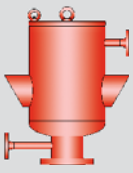

Vacuum Relief Valve in a special heat jacketed design

PROTEGO® SV/T-0-H

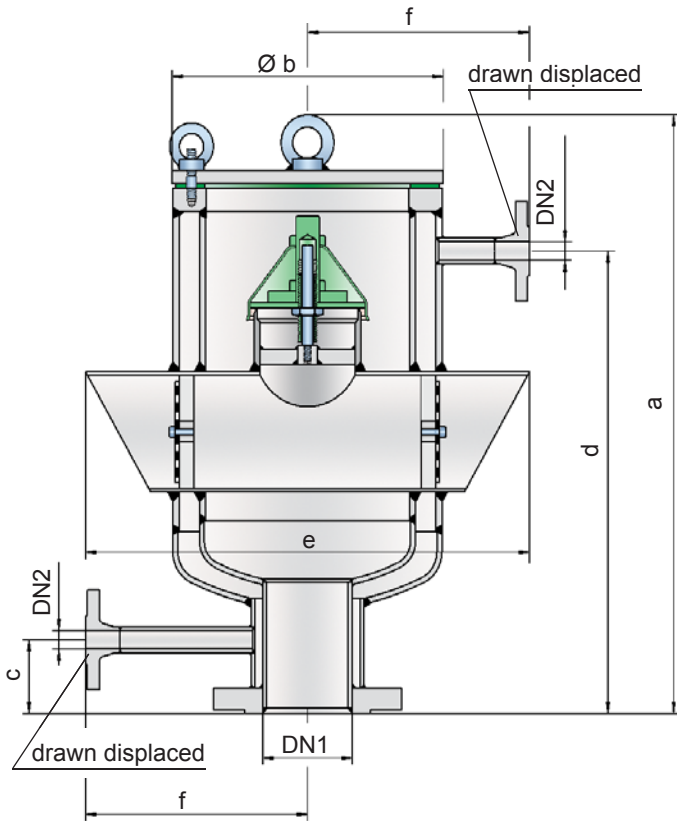

Vacuum settings:

-7 mbar up to -50 mbar
-2.8 inch W.C. up to -20 inch W.C.
Higher and lower vacuum settings upon request.

Function and Description

The SV/T-0-H type PROTEGO® valve is a highly developed vacuum relief valve with a valve housing that comes with a heating jacket down to the flange. It is primarily used as a safety device for inbreathing to tanks, containers, and process engineering equipment under difficult operating conditions. This includes extreme weather conditions or products that tend to form polymers at certain temperatures, adhere, or form deposits that negatively influence function (such as bitumen, tar, dust). The valve offers reliable protection against vacuum and prevents the intake of air close to the set vacuum.

When the set vacuum is reached, the valve starts to open and reaches full lift within a 40% vacuum increase. Up to the set vacuum, the tank vacuum is maintained with a seal that is far superior to the conventional standard due to the highly developed manufacturing technology. This feature is achieved by valve seats made of high quality stainless steel with precisely lapped valve pallets and a reinforced housing design. After the vacuum is relieved, the valve reseats and again provides a tight seal.

Special Features and Advantages

- excellent tightness and hence least possible product losses and reduced environmental pollution
- high flow capacity
- the valve pallet is guided within the housing to protect against harsh weather conditions
- can be used in areas subject to an explosion hazard
- complete heat jacketed design down to the flange to avoid cold bridges
- maximum permissible heating medium temperature of 320°C / 608°F (at 6 bar / 87 psi)
- a special design that preheats incoming air is also available
- a special design with a heatable valve cover is also available
- the valve pallet cover prevents the set pressure from being distorted by dust or condensate
- reinforced housing design
- a special design with a mechanical vent pallet lift device is available

Design Types and Specifications

The valve pallet is weight-loaded.

Vacuum valve in basic design with heating jacket

SV/T - 0 - H

Additional special devices available upon request.

Table 1: Dimensions

Dimensions in mm / inches

To select the nominal size (DN) use the capacity chart on the following page

DN1	80 / 3" *	100 / 4"	150 / 6"	200 / 8"	250 / 10"
DN2	15 / ½"	15 / ½"	15 / ½"	15 / ½"	15 / ½"
a	570 / 22.44	570 / 22.44	720 / 28.35	920 / 36.22	1050 / 41.34
b	275 / 10.83	275 / 10.83	355 / 13.98	405 / 15.94	508 / 20.00
c	70 / 2.76	70 / 2.76	60 / 2.36	70 / 2.76	70 / 2.76
d	440 / 17.32	440 / 17.32	590 / 23.23	790 / 31.10	920 / 36.22
e	450 / 17.72	450 / 17.72	650 / 25.59	750 / 29.53	950 / 37.40
f	225 / 8.86	225 / 8.86	260 / 10.24	300 / 11.91	350 / 13.78

* also available with special flange DN 50 / 2"

Table 2: Material selection for housing

Design	A	B	
Housing	Steel	Stainless Steel	Special materials upon request
Heating jacket	Steel	Stainless Steel	
Valve seat	Stainless Steel	Stainless Steel	
Sealing	PTFE	PTFE	

Table 3: Material selection for vacuum valve pallet

Design	A	B	C	
Vacuum range (mbar) (inch W.C.)	-7.0 up to -25 -2.8 up to -10	-10 up to -30 -4.0 up to -12	-30 up to -50 -12 up to -20	Special materials and other vacuum settings are available upon request
Valve pallet	Aluminium	Stainless Steel	Stainless Steel	
Valve pallet hood	Stainless Steel	Stainless Steel	Stainless Steel	
Sealing	Metal to Metal	Metal to Metal	Metal to Metal	

Table 4: Flange connection type

EN 1092-1; Form B1	other types upon request
ASME B16.5; 150 lbs RF5F	



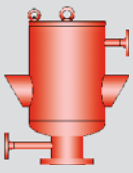

Vacuum Relief Valve

Flow Capacity Chart

PROTEGO® SV/T-0-H

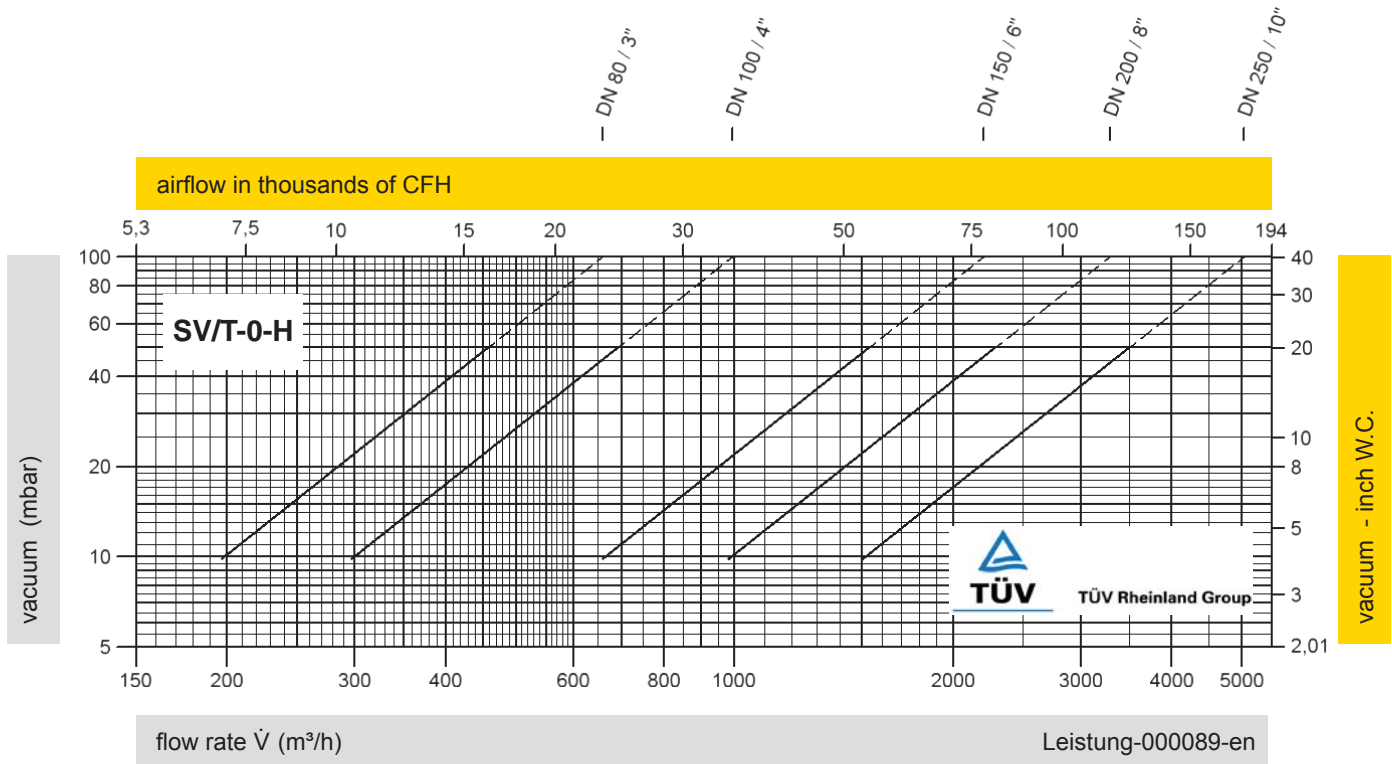

Remark

$$\text{set pressure} = \frac{\text{opening pressure resp. tank design pressure}}{1.4}$$

Set pressure = the valve starts to open

Opening pressure = set pressure plus overpressure

Overpressure = pressure increase over the set pressure

The flow capacity chart has been determined with a calibrated and TÜV certified flow capacity test rig.

Volume flow \dot{V} in (m³/h) and CFH refer to the standard reference conditions of air ISO 6358 (20°C, 1bar).

Conversion to other densities and temperatures refer to Vol. 1: "Technical Fundamentals".

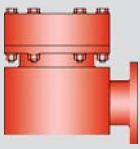

Vacuum Relief Valve

made of plastic

PROTEGO® V/KSM

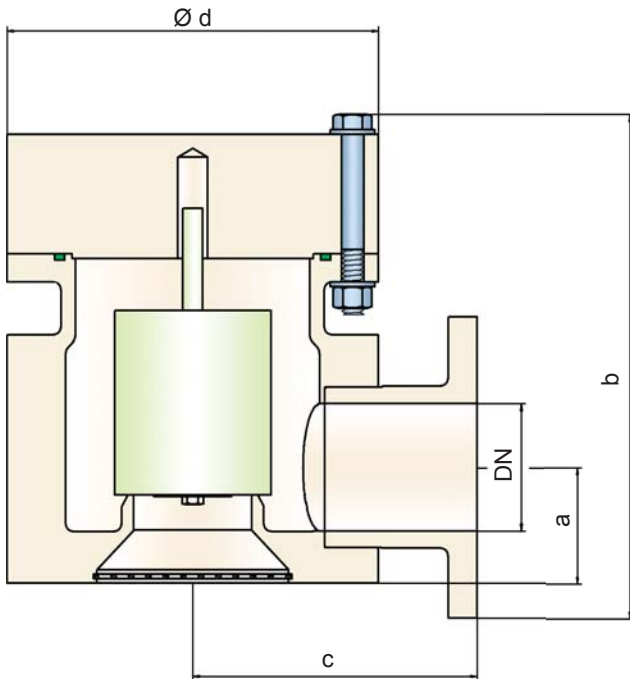

Vacuum settings:

- 6.0 mbar up to -100 mbar (DN 50/2")
- 2.4 inch W.C. up to -40 inch W.C.
- 4.0 mbar up to -100 mbar (DN 80/3")
- 1.6 inch W.C. up to -40 inch W.C.
- 4.5 mbar up to -100 mbar (DN 100/4" - DN 200/8")
- 1.8 inch W.C. up to -40 inch W.C.

Higher pressure settings upon request.

Function and Description

The PROTEGO® valve V/KSM is a state-of-the-art vacuum relief valve with excellent flow performance made of highgrade synthetic material. It is used as a safety device to relieve vacuum in tanks, containers, and process engineering equipment; it prevents the inbreathing of air until reaching the set vacuum. The valve is a perfect solution for corrosive, polymerizing or sticky media.

The device will start to open as soon as the set vacuum is reached and is fully open within 10% vacuum increase. Continuous investments into research and development have

allowed PROTEGO® to develop a low pressure valve which has the same opening characteristic as a high pressure safety relief valve. This "full lift type" technology allows the valve to be set just 10% below the maximum allowable working vacuum (MAWV) of the tank and still safely vent the required mass flow.

Due to our highly developed manufacturing technology, the tank pressure is maintained up to the set vacuum, with a seal that is far superior to the conventional standard. This feature is achieved by valve seats made of high-performance plastics and a high grade PTFE seal. After the vacuum is compensated, the valve reseats and provides a tight seal.

The optimized fluid dynamic design of the valve body and valve pallet is a result of many years of research work, which allow a stable operation of the valve pallet and optimized performance resulting in reduction of product losses.

Special Features and Advantages

- "full lift type" technology valve utilizes only 10% overpressure to reach full lift
- extreme tightness and hence least possible product losses and reduced environmental pollution
- the set pressure is close to the opening pressure which results in best possible pressure management of the system
- the valve pallet is guided within the housing to protect against harsh weather conditions
- corrosion resistant valve
- perfect solution for corrosive, polymerizing and sticky media
- weight reduction in comparison to steel/stainless steel
- smooth surface
- automatic condensate drain
- different plastics can be combined
- maintenance friendly design

Design Types and Specifications

The valve pallet is weight-loaded, and the highest pressure levels are only attained with metal discs.

Vacuum valve in basic design

V/KSM-

Additional special devices available upon request.

Table 1: Dimensions

Dimensions in mm / inches

To select the nominal size (DN), use the flow capacity chart on the following page

DN	50 / 2"	80 / 3"	100 / 4"	150 / 6"	200 / 8"
a	57 / 2.24	77 / 3.03	87 / 3.43 (115 / 4.53)*	126 / 4.96 (146 / 5.75)*	180 / 7.09 (175 / 6.89)*
b	259 / 10.20	376 / 14.80	373 / 14.69 (338 / 13.31)*	460 / 18.11 (427 / 16.81)*	469 / 18.46 (437 / 17.20)*
c	150 / 5.91	200 / 7.87	225 / 8.86	280 / 11.02	350 / 13.78
d	180 / 7.09	250 / 9.84	300 / 11.81	350 / 13.78 (405 / 15.94)*	560 / 22.05 (500 / 19.68)*

* Dimensions in brackets only for PVDF



Vents for corrosive vapor service
(Flyer pdf)



Vents - 10% Technology
(Flyer pdf)



Leak Rate/10% Technology
(Flyer pdf)

Table 2: Material selection for housing

Design	A	B	C
Housing	PE	PP	PVDF
Valve seat	PE	PP	PVDF
Sealing	FPM	FPM	FPM
Valve pallet	A, C, D	B, C, D	C, D

Special Materials upon request

Table 3: Material selection for vacuum valve pallet

Design	A	B	C	D
Vacuum range (mbar) (inch W.C.)	-6.0 up to -16 -2.4 up to -6.4	-5.5 up to -16 -2.2 up to -6.4	-9.5 up to -30 -3.8 up to -12	-30 up to -100 -12 up to -40
Valve pallet	PE	PP	PVDF	Hastelloy
Sealing	PTFE	PTFE	PTFE	PTFE
Spindle guide	PE	PP	PVDF	Hastelloy
Weight	PE	PP	PVDF	Hastelloy

Special materials and other vacuum settings are available upon request

Table 4: Flange connection type

EN 1092-1; Form A	other types upon request
ASME B16.5; 150 lbs FFSF	

Flow Capacity Chart

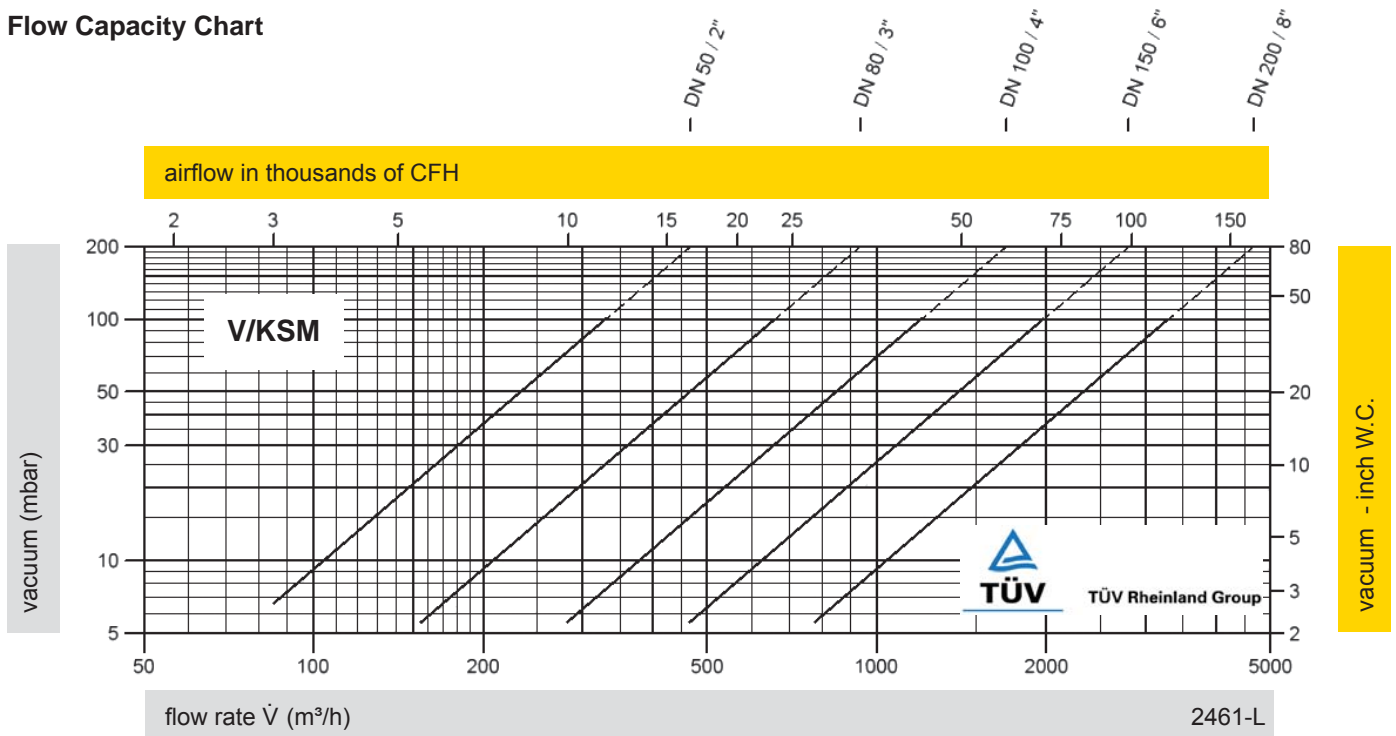

The flow capacity chart has been determined with a calibrated and TÜV certified flow capacity test rig. Volume flow \dot{V} in m^3/h and CFH refer to the standard reference conditions of air ISO 6358 (20°C, 1bar). Conversion to other densities and temperatures refer to Vol. 1: "Technical Fundamentals".



for safety and environment

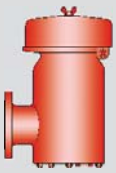

Pressure and Vacuum Relief Valve



PROTEGO® PV/EL

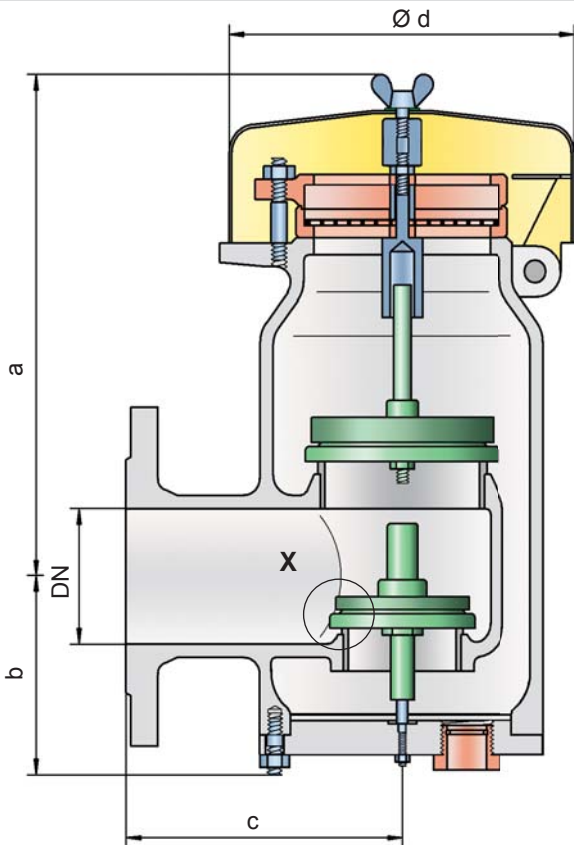

Detail X

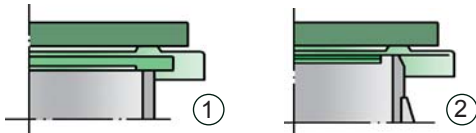

Settings:

Pressure: +2.0 mbar up to +210 mbar
 +0.8 inch W.C. up to +84 inch W.C.

Vacuum: -14 mbar up to -35 mbar
 -5.6 inch W.C. up to -14 inch W.C.

vacuum: -3.5 mbar up to -14 mbar
 -1.4 inch W.C. up to -5.6 inch W.C.

for pressure up to max. + 150 mbar / 60.2 inch W.C.
 Higher and lower settings upon request.

Function and Description

The PV/EL type PROTEGO® valve is a highly developed combined pressure and vacuum relief valve. It is primarily used as a safety device for relieving pressure and vacuum in tanks, containers and process engineering equipment. The valve offers reliable protection against overpressure and excessive vacuum. It prevents also the impermissible loss of product vapors close to the set pressure as well as the intake of air on the vacuum side close to set vacuum.

The device will start to open as soon as the set pressure is reached and only requires 10% overpressure to full lift. Continuous investments into research and development have

allowed PROTEGO® to develop a low pressure valve which has the same opening characteristic as a high pressure safety relief valve. This “full lift type” technology allows the valve to be set just 10% below the maximum allowable working pressure or vacuum (MAWP or MAWV) of the tank and still safely vent the required mass flow. The opening characteristic is the same for pressure and vacuum relief.

Due to the highly developed manufacturing technology, the tank pressure is maintained up to the set pressure, with a tightness that is far superior to the conventional standard. This feature is achieved by valve seats made of high quality stainless steel and with precisely lapped valve pallets (1) or with an air cushion seal (2) in conjunction with high quality FEP diaphragm. The valve pallets are also available with a PTFE seal to prevent the valve pallet from sticking when sticky products are used, and they enable the use of corrosive media. After the excess pressure is discharged or the vacuum is compensated, the valve reseats and provides a tight seal.

The optimized fluid dynamic design of the valve body and valve pallet is a result of many years of research work, which allow a stable operation of the valve pallet and optimized performance resulting in reduction of product losses.

Special Features and Advantages

- “full lift type” technology valve utilizes only 10% overpressure to reach full lift
- extreme tightness and hence least possible product losses and reduced environmental pollution
- the set pressure is close to the opening pressure which results in best possible pressure management of the system
- high flow capacity
- the valve pallet is guided within the housing to protect against freezing in cold weather
- can be used in areas subject to an explosion hazard
- self-actuated condensate drain
- special design with lifting gear can be purchased

Design Types and Specifications

The valve pallets are weight-loaded. At set pressures greater than 60 mbar (24.1 inch W.C.), an elongated construction is used.

There are two different designs

Pressure/vacuum relief valve in basic design **PV/EL - []**

Pressure/vacuum relief valve with heating jacket **PV/EL - [H]**

Additional special devices available upon request.

Any combination of vacuum and pressure levels can be set for the valve. When the difference between the pressure and vacuum exceeds 150 mbar / 60.2 inch W.C., special valve pallets are used.



Vents - 10% Technology
(Flyer pdf)



Leak Rate/10% Technology
(Flyer pdf)



The optimised valve pallet
(Flyer pdf)

Table 1: Dimensions

Dimensions in mm / inches

To select the nominal size (DN), please use the flow capacity charts on the following pages

DN	50 / 2"	50 / 2"	80 / 3"	80 / 3"
Set pressure	≤ +60 mbar ≤ +24.1 inch W.C.	> +60 mbar > +24.1 inch W.C.	≤ +60 mbar ≤ +24.1 inch W.C.	> +60 mbar > +24.1 inch W.C.
a	308 / 12.13	443 / 17.44	308 / 12.13	443 / 17.44
b	108 / 4.25	108 / 4.25	108 / 4.25	108 / 4.25
c	165 / 6.50	165 / 6.50	167 / 6.57	167 / 6.57
d	218 / 8.58	218 / 8.58	218 / 8.58	218 / 8.58

Dimensions for pressure/
vacuum relief valve with
heating jacket upon request

Table 2: Material selection for housing

Design	B	C
Housing	Steel	Stainless Steel
Heating jacket (PV/EL-H-...)	Steel	Stainless Steel
Valve seat	Stainless Steel	Stainless Steel
Weather hood	Steel	Stainless Steel
Protective mesh screen	Stainless Steel	Stainless Steel

Special materials upon request

Table 3: Material selection for pressure valve pallet

Design	A	B	C	D
Pressure range (mbar) (inch W.C.)	+2.0 up to +3.5 +0.8 up to +1.4	>+3.5 up to +14 >+1.4 up to +5.6	>+14 up to +210 >+5.6 up to +84	>+14 up to +210 >+5.6 up to +84
Valve pallet	Aluminium	Stainless Steel	Stainless Steel	Stainless Steel
Sealing	FEP	FEP	Metal to Metal	PTFE

Special material as well as
higher set pressure upon
request

Table 4: Material selection for vacuum valve pallet

Design	A	B	C	D
Vacuum range (mbar) (inch W.C.)	-3.5 up to -5.0 -1.4 up to -2.0	<-5.0 up to -14 <-2.0 up to -5.6	<-14 up to -35 <-5.6 up to -14	<-14 up to -35 <-5.6 up to -14
Valve pallet	Aluminium	Stainless Steel	Stainless Steel	Stainless Steel
Sealing	FEP	FEP	Metal to Metal	PTFE

Special material as well as
higher set vacuum upon
request

Table 5: Flange connection type

EN 1092-1; Form B1	other types upon request
ASME B16.5; 150 lbs RFSF	



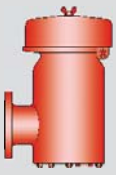

Pressure and Vacuum Relief Valve

Flow Capacity Charts

PROTEGO® PV/EL

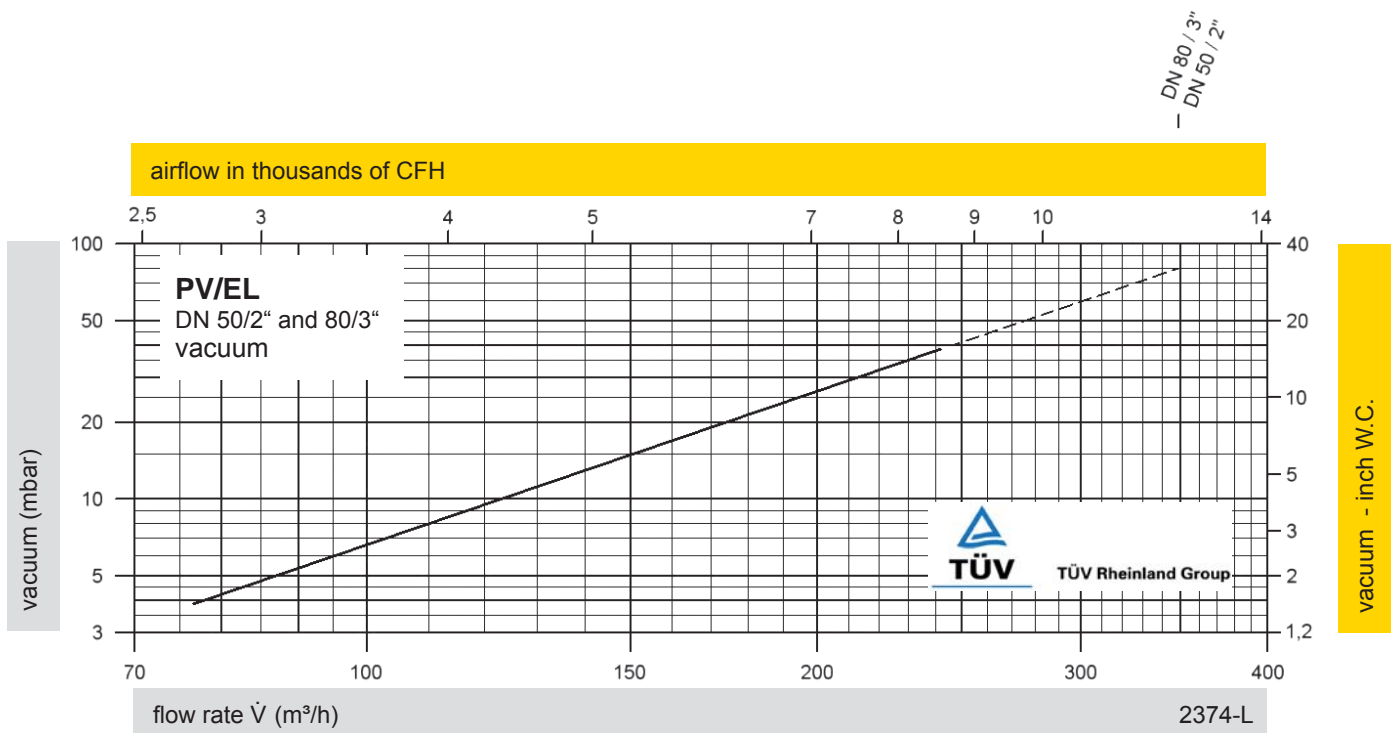
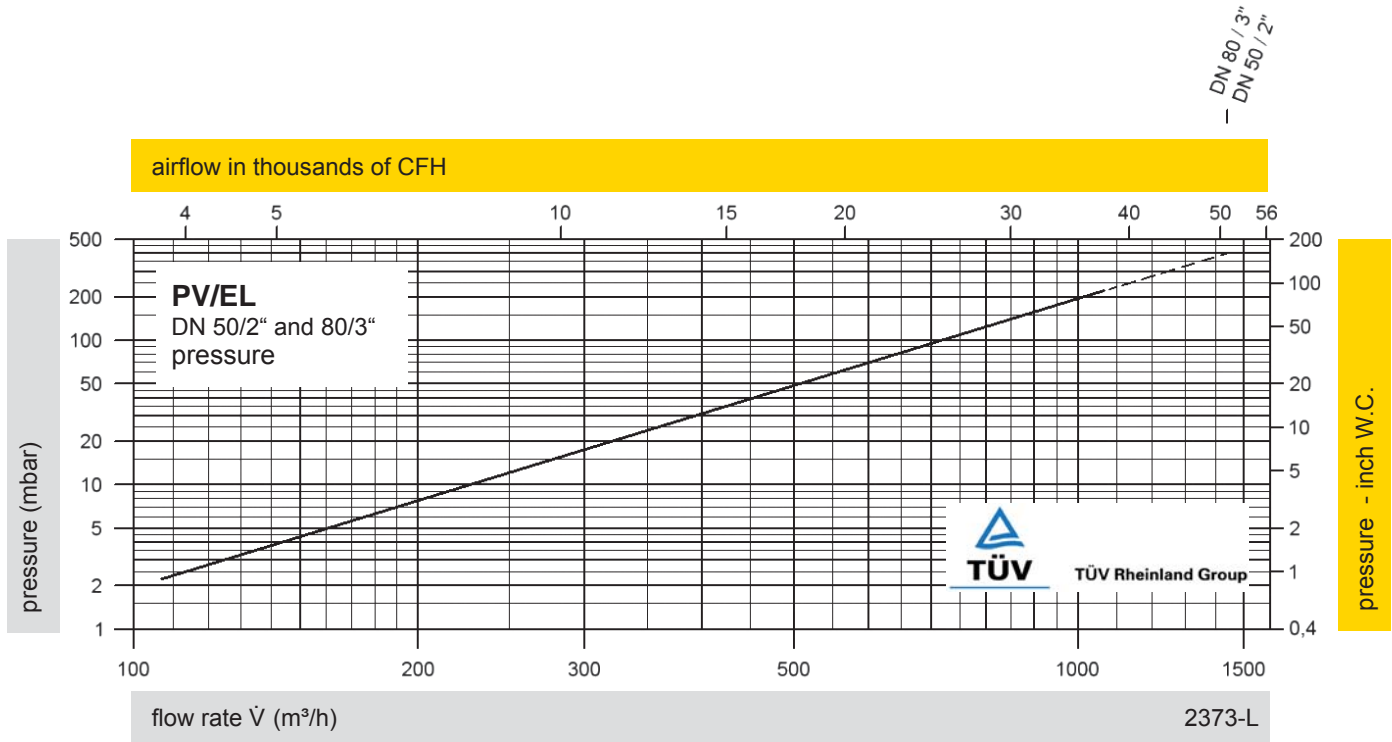

The flow capacity charts have been determined with a calibrated and TÜV certified flow capacity test rig. Volume flow \dot{V} in (m³/h) and CFH refer to the standard reference conditions of air ISO 6358 (20°C, 1bar). Conversion to other densities and temperatures refer to Vol. 1: "Technical Fundamentals".

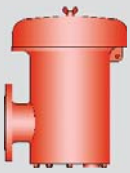

Pressure and Vacuum Relief Valve



PROTEGO® PV/ELR

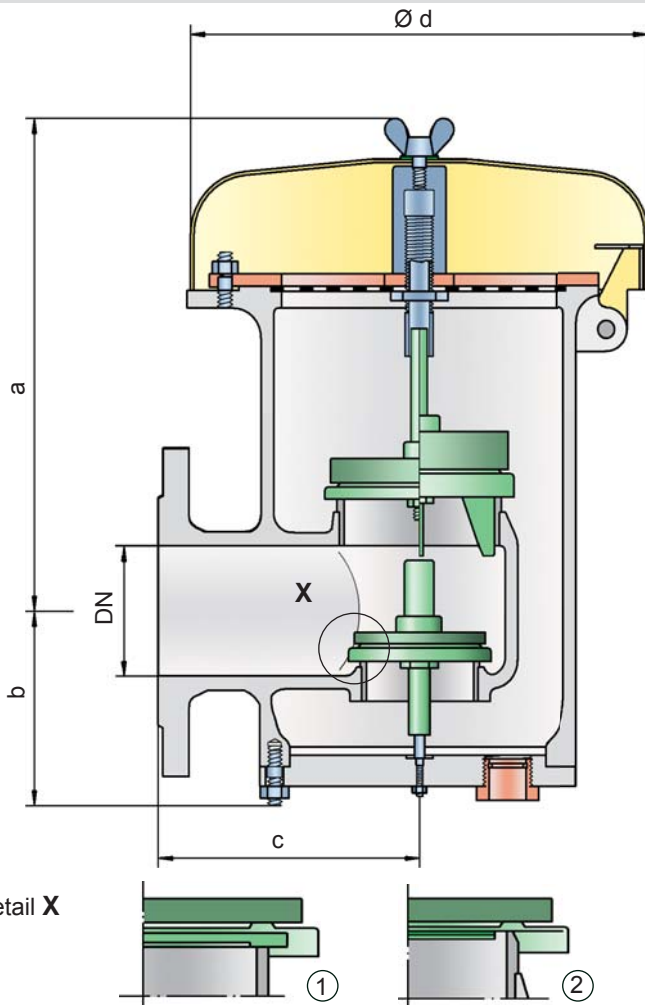

set just 10% below the maximum allowable working pressure or vacuum (MAWP or MAWV) of the tank and still safely vent the required mass flow. The opening characteristic is the same for pressure and vacuum relief.

Due to the highly developed manufacturing technology, the tank pressure is maintained up to the set pressure, with a tightness that is far superior to the conventional standard. This feature is achieved by valve seats made of high quality stainless steel and with precisely lapped valve pallets (1) or with an air cushion seal (2) in conjunction with high quality FEP diaphragm. The valve pallets are also available with a PTFE seal to prevent the valve pallet from sticking when sticky products are used, and they enable the use of corrosive media. After the excess pressure is discharged or the vacuum is compensated, the valve reseats and provides a tight seal.

The optimized fluid dynamic design of the valve body and valve pallet is a result of many years of research work, which allow a stable operation of the valve pallet and optimized performance resulting in reduction of product losses.

Special Features and Advantages

- “full lift type” technology valve utilizes only 10% overpressure to reach full lift
- extreme tightness and hence least possible product losses and reduced environmental pollution
- the set pressure is close to the opening pressure which results in best possible pressure management of the system
- high flow capacity
- the valve pallet is guided within the housing to protect against freezing in cold weather
- can be installed in explosion hazardous areas
- self-actuated condensate drain
- compact design saves space
- special design with lifting gear can be purchased
- maintenance friendly design

Design Types and Specifications

The valve pallets are weight-loaded. At set pressures greater than 35 mbar (14 inch W.C.), an elongated construction is used.

There are two different designs:

Pressure/vacuum relief valve in basic design **PV/ELR** -

Pressure/vacuum relief valve with heating jacket **PV/ELR** - H

Additional special devices available upon request.

Any combination of vacuum and pressure levels can be set for the valve. When the difference between the pressure and vacuum exceeds 150 mbar/60.2 inch W.C., special valve pallets are used.

Settings:

Pressure: +2.0 mbar up to +210 mbar
+0.8 inch W.C. up to +84 inch W.C.

Vacuum: -14 mbar up to -50 mbar
-5.6 inch W.C. up to -20 inch W.C.

vacuum: -3.5 mbar up to -14 mbar
-1.4 inch W.C. up to -5.6 inch W.C.

for pressure up to max. + 150 mbar / 60.2 inch W.C.

Higher and lower settings upon request

Function and Description

The PV/ELR type PROTEGO® valve is a highly developed combined pressure and vacuum relief valve with excellent flow performance. Typically the valve is installed in the in- and outbreathing lines of tanks, vessels and process apparatus to protect against unallowable high and low pressure. The valve prevents emission losses almost up to the set pressure and prevents air intake almost up to set vacuum.

The device will start to open as soon as the set pressure is reached and only requires 10% overpressure to full lift. Continuous investments into research and development have allowed PROTEGO® to develop a low pressure valve which has the same opening characteristic as a high pressure safety relief valve. This “full lift type” technology allows the valve to be



Vents - 10% Technology
(Flyer pdf)



Leak Rate/10% Technology
(Flyer pdf)



The optimised valve pallet
(Flyer pdf)

Table 1: Dimensions

Dimensions in mm / inches

To select the nominal size (DN), please use the flow capacity charts on the following pages

DN	80 / 3"	80 / 3"	100 / 4"	100 / 4"
Set pressure	≤ +35 mbar ≤ +14 inch W.C.	> +35 mbar > +14 inch W.C.	≤ +35 mbar ≤ +14 inch W.C.	> +35 mbar > +14 inch W.C.
a	345 / 13.58	475 / 18.70	345 / 13.58	475 / 18.70
b	146 / 5.75	146 / 5.75	146 / 5.75	146 / 5.75
c	218 / 8.58	218 / 8.58	218 / 8.58	218 / 8.58
d	353 / 13.90	353 / 13.90	353 / 13.90	353 / 13.90

Dimensions for pressure/
vacuum relief valve with
heating jacket upon request

Table 2: Material selection for housing

Design	B	C
Housing	Steel	Stainless Steel
Heating jacket (PV/ELR-H-...)	Steel	Stainless Steel
Valve seat	Stainless Steel	Stainless Steel
Weather hood	Steel	Stainless Steel
Protective mesh screen	Stainless Steel	Stainless Steel

Special materials upon request

Table 3: Material selection for pressure valve pallet

Design	A	B	C	D
Pressure range (mbar) (inch W.C.)	+2.0 up to +3.5 +0.8 up to +1.4	>+3.5 up to +14 >+1.4 up to +5.6	>+14 up to +210 >+5.6 up to +84	>+14 up to +210 >+5.6 up to +84
Valve pallet	Aluminium	Stainless Steel	Stainless Steel	Stainless Steel
Sealing	FEP	FEP	Metal to Metal	PTFE

Special material as well as
higher set pressure upon
request

Table 4: Material selection for vacuum valve pallet

Design	A	B	C	D
Vacuum range (mbar) (inch W.C.)	-3.5 up to -5.0 -1.4 up to -2.0	<-3.5 up to -14 <-2.0 up to -5.6	<-14 up to -50 <-5.6 up to -20	<-14 up to -50 <-5.6 up to -20
Valve pallet	Aluminium	Stainless Steel	Stainless Steel	Stainless Steel
Sealing	FEP	FEP	Metal to Metal	PTFE

Special material as well as
higher set vacuum upon
request

Table 5: Flange connection type

EN 1092-1; Form B1	other types upon request
ASME B16.5; 150 lbs RFSF	



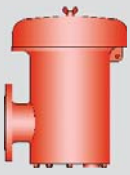

Pressure and Vacuum Relief Valve

Flow Capacity Charts

PROTEGO® PV/ELR

DN 100 / 4"
-
DN 80 / 3"

airflow in thousands of CFH

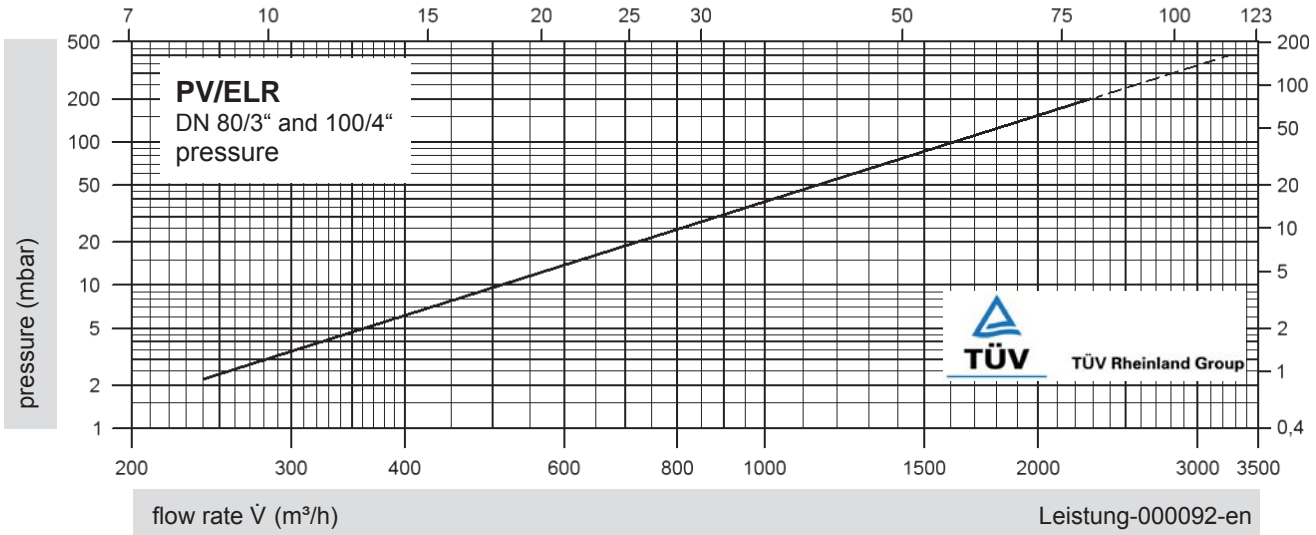

DN 100 / 4"
-
DN 80 / 3"

airflow in thousands of CFH

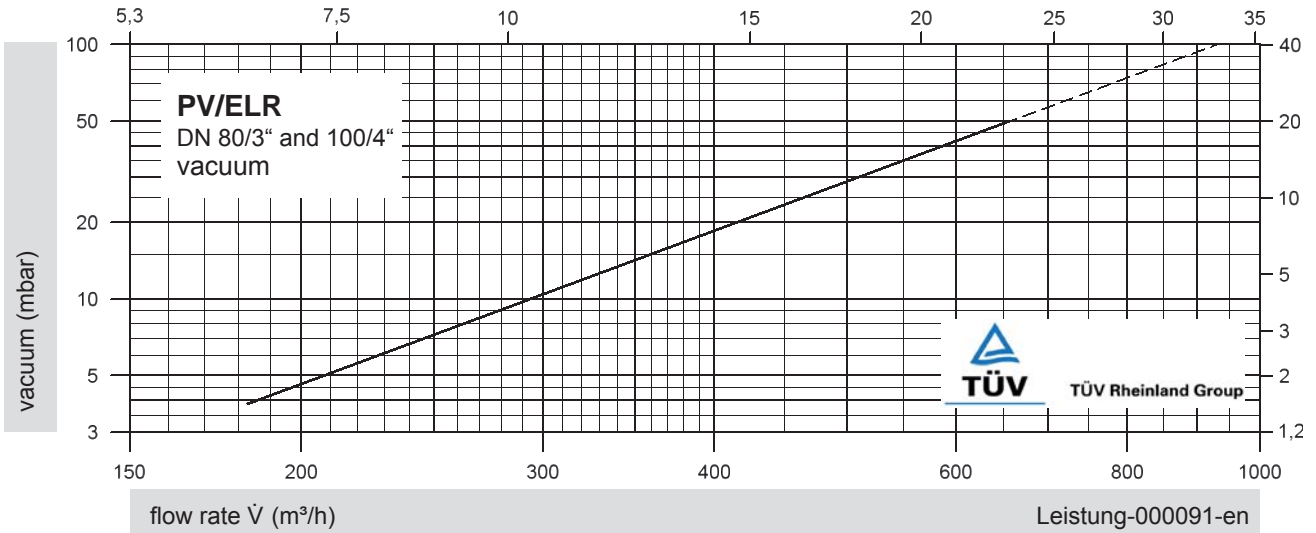

The flow capacity charts have been determined with a calibrated and TÜV certified flow capacity test rig.
Volume flow \dot{V} in (m³/h) and CFH refer to the standard reference conditions of air ISO 6358 (20°C, 1bar).
Conversion to other densities and temperatures refer to Vol. 1: "Technical Fundamentals".



Pressure and Vacuum Relief Valve



PROTEGO® VD/SV

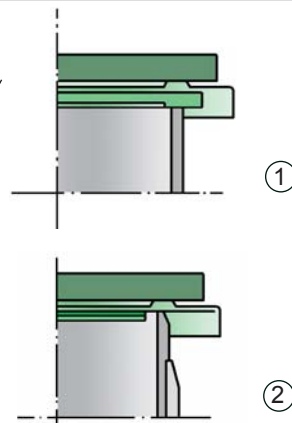
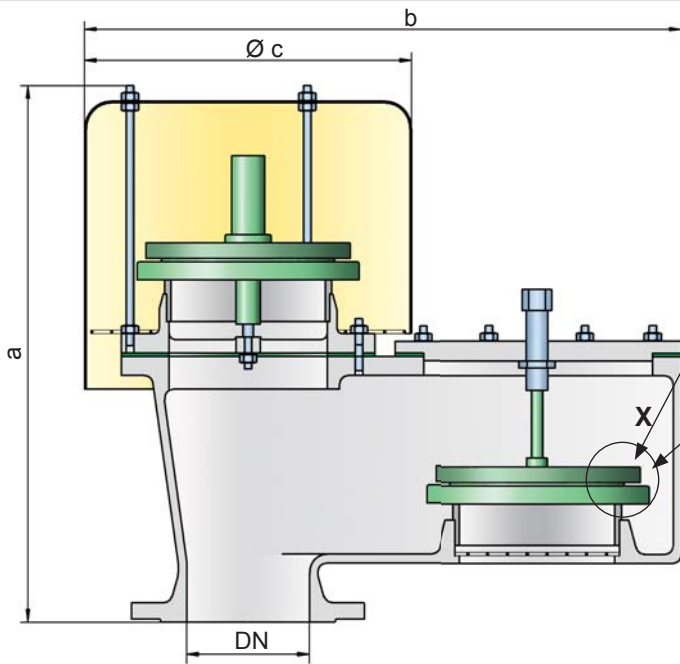

Settings:

Pressure: +2.0 mbar up to +60 mbar
+0.8 inch W.C. up to +24 inch W.C.

Vacuum: -2.0 mbar up to -60 mbar
-0.8 inch W.C. up to -24 inch W.C.

Higher or lower settings upon request.

Function and Description

The VD/SV type PROTEGO® valve is a highly developed pressure and vacuum relief valve with excellent flow performance. Typically the valve is installed in the in- and outbreathing lines of tanks, vessels and process apparatus to protect against unallowable high and low pressure. The valve prevents emission losses almost up to the set pressure and prevents air intake almost up to set vacuum.

The device will start to open as soon as the set pressure is reached and only requires 10% overpressure to full lift. Continuous investments into research and development have allowed PROTEGO® to develop a low pressure valve which has the same opening characteristic as a high pressure safety relief valve. This “full lift type” technology allows the valve to be set just 10% below the maximum allowable working pressure or vacuum (MAWP or MAWV) of the tank and still safely vent the required mass flow. The opening characteristic is the same for pressure and vacuum relief.

Due to our highly developed manufacturing technology the tank pressure is maintained up to set pressure with a tightness that is far superior to the conventional standard. This feature is achieved by valve seats made of high quality stainless steel and with precisely lapped valve pallets (1) or with an air cushion seal (2) in conjunction with high quality FEP diaphragm. The valve pallets are also available with a PTFE seal to prevent the valve pallets from sticking when sticky products are used and to enable the use of corrosive fluids. After the excess pressure is discharged or the vacuum is compensated, the valve reseats and provides a tight seal.

The optimized fluid dynamic design of the valve body and valve pallet is a result of many years of research work, which allow a stable operation of the valve pallet and optimized performance resulting in reduction of product losses.

Special Features and Advantages

- “full lift type” technology valve utilizes only 10% overpressure to reach full lift
- extreme tightness and hence least possible product losses and reduced environmental pollution
- the set pressure is close to the opening pressure which results in best possible pressure management of the system
- very high flow capacity
- the valve pallet is guided within the housing to protect against harsh weather conditions
- can be used in areas subject to explosion hazards
- self draining
- maintenance friendly design
- best technology for API-tanks

Design Types and Specifications

The valve pallets are weight-loaded. Higher pressures can be achieved upon request with a special spring-loaded design.

There are two different designs:

Pressure/vacuum valve in basic design **VD/SV-□**

Pressure/vacuum relief valve with heating jacket **VD/SV-H**

Additional special devices available upon request.

Any combination of vacuum and pressure levels can be set for the valve. When the difference between the pressure and vacuum exceeds 150 mbar / 60.2 inch W.C., special valve pallets are used.



Vents - 10% Technology
(Flyer pdf)



Leak Rate/10% Technology
(Flyer pdf)



Coated Devices
(Flyer pdf)



The optimised valve pallet
(Flyer pdf)

Table 1: Dimensions

Dimensions in mm / inches

To select the nominal size (DN), use the flow capacity chart on the following page

DN	40 / 1 ½"	50 / 2"	80 / 3"	100 / 4"	150 / 6"	200 / 8"	250 / 10"	300 / 12"
a	396 / 15.59	396 / 15.59	497 / 19.57	519 / 20.43	654 / 25.75	757 / 29.80	802 / 31.57	802 / 31.57
b	355 / 13.98	355 / 13.98	448 / 17.64	548 / 21.57	788 / 31.02	900 / 35.43	1030 / 40.55	1030 / 40.55
c	200 / 7.87	200 / 7.87	295 / 11.61	295 / 11.61	465 / 18.31	550 / 21.65	650 / 25.59	650 / 25.59

Dimensions of pressure and vacuum relief valves with heating jacket upon request

Table 2: Material selection for housing

Design	A	B	C	
Housing	Aluminium	Steel	Stainless Steel	Option: Housing ECTFE-coated
Heating jacket (VD/SV-H-...)	–	Steel	Stainless Steel	
Valve seat	Stainless Steel	Stainless Steel	Stainless Steel	Special materials upon request
Sealing	PTFE	PTFE	PTFE	
Weather hood	Stainless Steel	Stainless Steel	Stainless Steel	

Table 3: Material selection for pressure valve pallet

Design	A	B	C	D	E	F
Pressure range (mbar)	+2.0 up to +3.5	>+3.5 up to +14	>+14 up to +35	>+35 up to +60	>+14 up to +35	>+35 up to +60
(inch W.C.)	+0.8 up to +1.4	>+1.4 up to +5.6	>+5.6 up to +14	>+14 up to +24	>+5.6 up to +14	>+14 up to +24
Valve pallet	Aluminium	Stainless Steel	Stainless Steel	Stainless Steel	Stainless Steel	Stainless Steel
Sealing	FEP	FEP	Metal to metal	Metal to metal	PTFE	PTFE

Special material as well as higher set pressure upon request

Table 4: Material selection for vacuum valve pallet

Design	A	B	C	D	E	F
Vacuum range (mbar)	-2.0 up to -3.5	<-3.5 up to -14	<-14 up to -35	<-14 up to -35	<-35 up to -60	<-35 up to -60
(inch W.C.)	-0.8 up to -1.4	<-1.4 up to -5.6	<-5.6 up to -14	<-5.6 up to -14	<-14 up to -24	<-14 up to -24
Valve pallet	Aluminium	Stainless Steel	Stainless Steel	Stainless Steel	Stainless Steel	Stainless Steel
Sealing	FEP	FEP	Metal to Metal	PTFE	Metal to Metal	PTFE

Special material as well as higher vacuum upon request

Table 5: Flange connection type

EN 1092-1; Form B1	other types upon request
ASME B16.5; 150 lbs RFSF	



Pressure and Vacuum Relief Valve

Flow Capacity Charts

PROTEGO® VD/SV

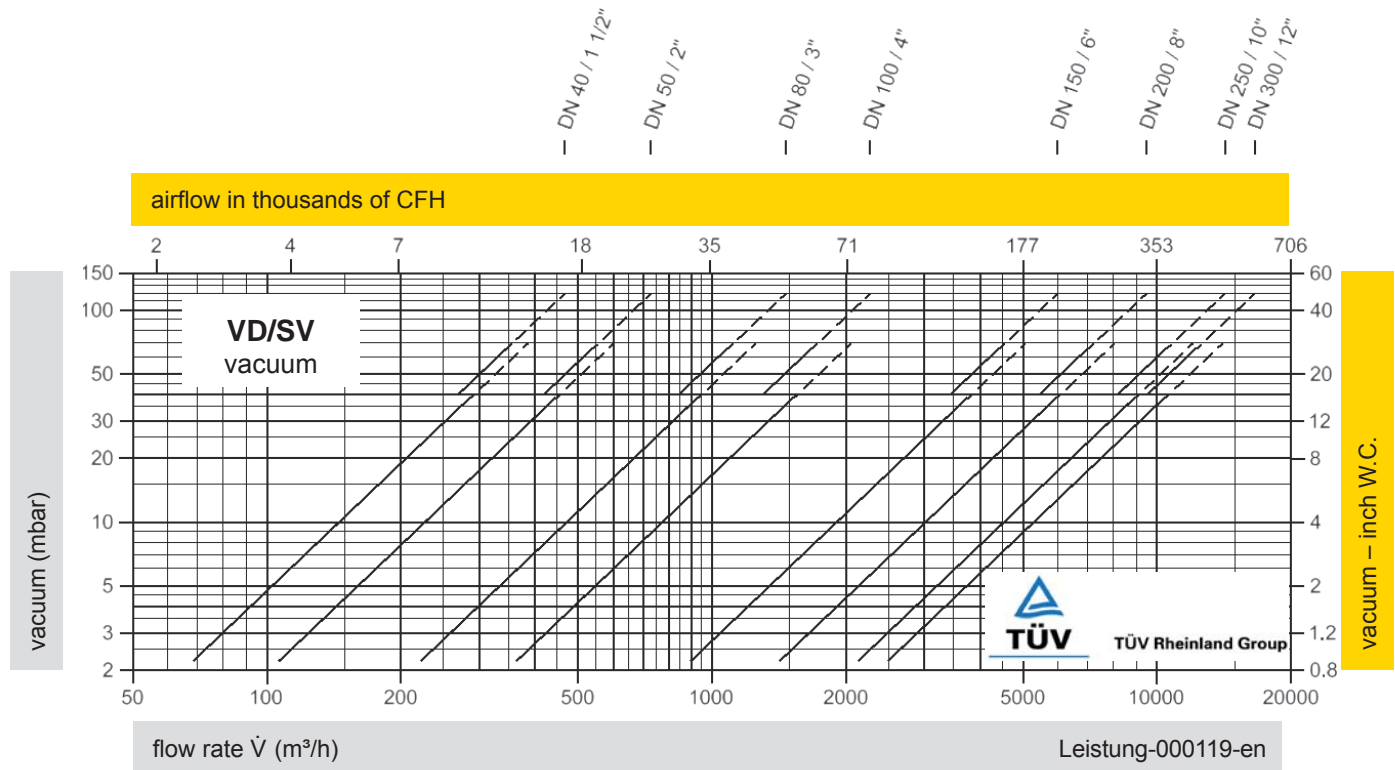
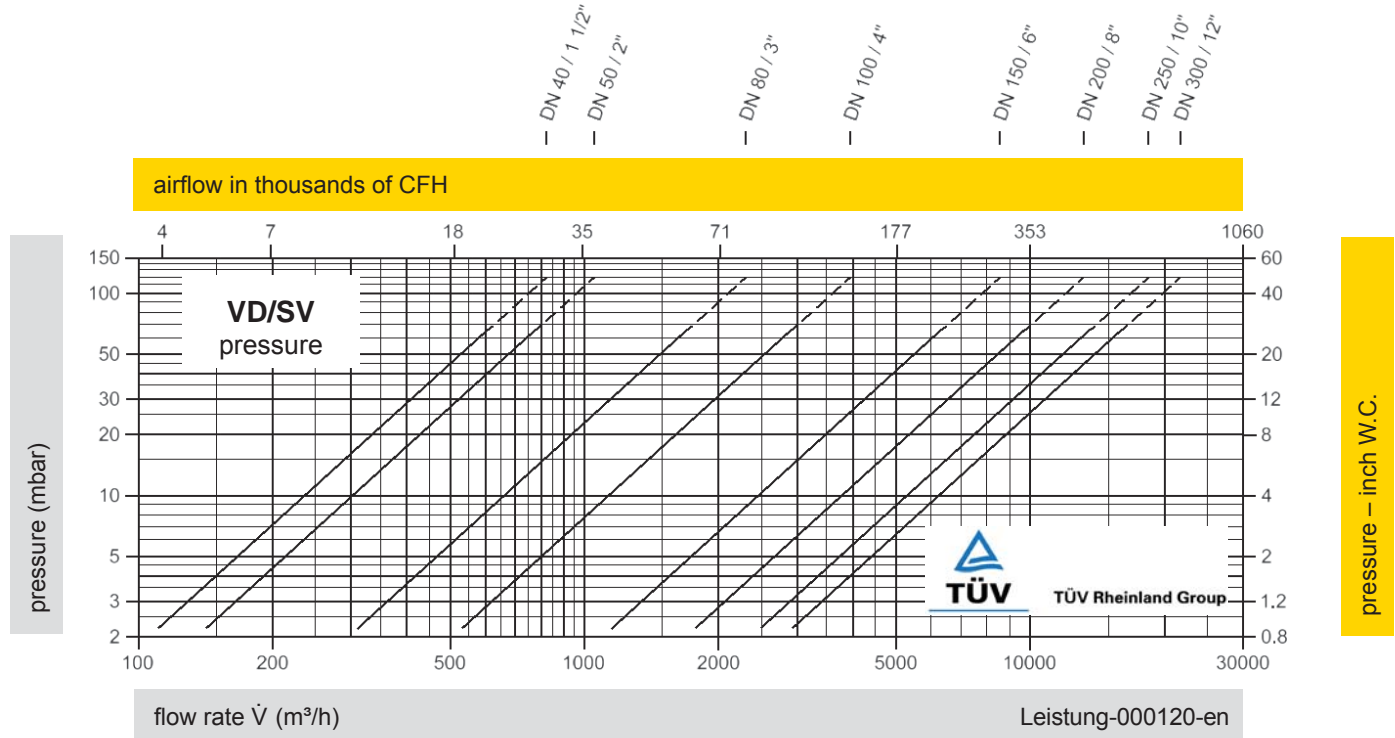

The flow capacity charts have been determined with a calibrated and TÜV certified flow capacity test rig. Volume flow \dot{V} in (m³/h) and CFH refer to the standard reference conditions of air ISO 6358 (20°C, 1bar). Conversion to other densities and temperatures refer to Vol. 1: "Technical Fundamentals".

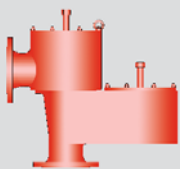

Pressure and Vacuum Relief Valve with pipe-away connection

PROTEGO® VD/SV-PA(L)

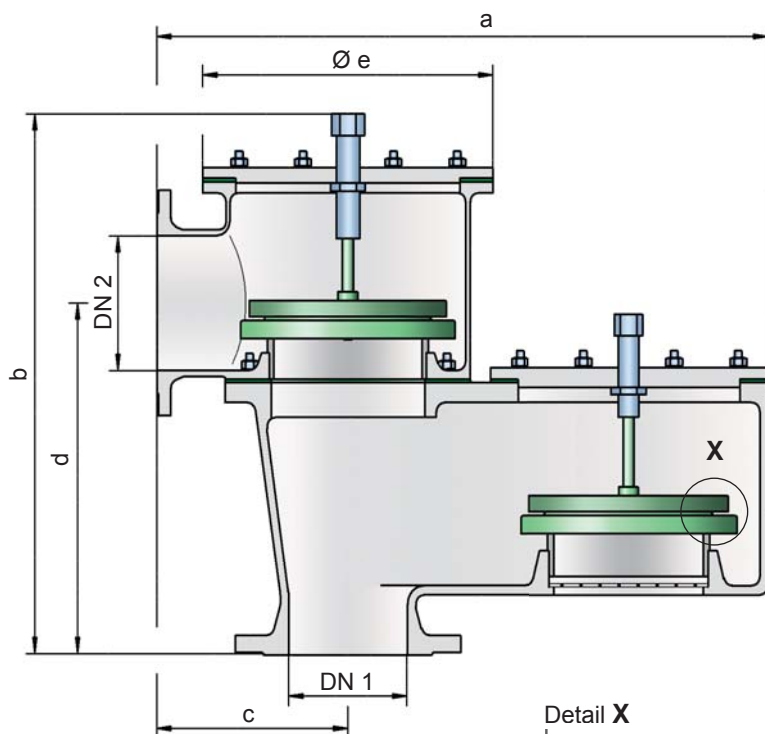

Settings:

Pressure: +2.0 mbar up to +60 mbar
+0.8 inch W.C. up to +24 inch W.C.

Vacuum: -2.0 mbar up to -60 mbar
-0.8 inch W.C. up to -24 inch W.C.

Higher or lower settings upon request.

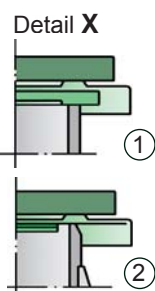

Function and Description

The VD/SV-PA(L) type PROTEGO® valve is a highly developed pressure and vacuum relief valve with excellent flow performance. Typically the valve is installed in the in- and outbreathing lines of tanks, vessels and process apparatus to protect against unallowable high and low pressure. The valve prevents emission losses almost up to the set pressure and prevents air intake almost up to set vacuum. The product vapors can be discharged through a collective line connected to the line flange on the pressure side.

The device will start to open as soon as the set pressure is reached and only requires 10% overpressure to full lift. Continuous investments into research and development have allowed PROTEGO® to develop a low pressure valve which has the same opening characteristic as a high pressure safety relief valve. This “full lift type” technology allows the valve to be set just 10% below the maximum allowable working pressure or vacuum (MAWP or MAWV) of the tank and still safely vent the required mass flow. The opening characteristic is the same for pressure and vacuum relief.

Due to our highly developed manufacturing technology the tank pressure is maintained up to set pressure with a tightness that is far superior to the conventional standard. This feature is achieved by

valve seats made of high quality stainless steel and with precisely lapped valve pallets (1) or with an air cushion seal (2) in conjunction with high quality FEP diaphragm. The valve pallets are also available with a PTFE seal to prevent the valve pallets from sticking when sticky products are used and to enable the use of corrosive fluids. After the excess pressure is discharged or the vacuum is compensated, the valve reseats and provides a tight seal.

The optimized fluid dynamic design of the valve body and valve pallet is a result of many years of research work, which allow a stable operation of the valve pallet and optimized performance resulting in reduction of product losses.

Special Features and Advantages

- “full lift type” technology valve utilizes only 10% overpressure to reach full lift
- extreme tightness and hence least possible product losses and reduced environmental pollution
- set pressure is close to the opening pressure which results in best possible pressure management of the system
- very high flow capacity
- can be used in areas subject to explosion hazards
- self draining
- maintenance friendly design
- best technology for API-tanks

Design Types and Specifications

The valve pallets are weight-loaded. Higher pressures can be achieved upon request with a special spring-loaded design. Choose the model (L) if the discharge nozzle has a nominal diameter that is greater than the nominal diameter of the tank filler neck.

There are four different designs:

- Pressure/vacuum valve in basic design **VD/SV-PA -**
- Pressure/vacuum valve with heating jacket **VD/SV-PA - H**
- Pressure/vacuum relief valve with DN2 > DN1 **VD/SV-PAL -**
- Pressure/vacuum relief valve with DN2 > DN1 with heating jacket **VD/SV-PAL - H**

Additional special devices available upon request.

Any combination of vacuum and pressure setting can be achieved for the valve. When the difference between the pressure and vacuum exceeds 150 mbar (60.2 inch W.C.), special valve pallets are used.



Vents - 10% Technology
(Flyer pdf)



Leak Rate/10% Technology
(Flyer pdf)



Coated Devices
(Flyer pdf)



The optimised valve pallet
(Flyer pdf)

Table 1: Dimensions

Dimensions in mm / inches

To select the nominal size (DN), use the flow capacity charts on the following pages

VD/SV-PA

DN 1	50 / 2"	80 / 3"	100 / 4"	150 / 6"	200 / 8"	250 / 10"	300 / 12"
DN 2	50 / 2"	80 / 3"	100 / 4"	150 / 6"	200 / 8"	250 / 10"	300 / 12"
a	405 / 15.95	480 / 18.90	600 / 23.62	805 / 31.69	925 / 36.42	1010 / 39.76	1010 / 39.76
b	390 / 15.35	485 / 19.09	550 / 21.65	660 / 25.98	780 / 30.71	875 / 34.45	875 / 34.45
c	150 / 5.91	180 / 7.09	200 / 7.87	250 / 9.84	300 / 11.81	305 / 12.01	305 / 12.01
d	240 / 9.45	300 / 11.81	330 / 12.99	390 / 15.35	480 / 18.90	555 / 21.85	582 / 22.91
e	165 / 6.50	192 / 7.56	240 / 9.45	350 / 13.78	390 / 15.35	460 / 18.11	460 / 18.11

VD/SV-PAL

DN 1	50 / 2"	80 / 3"	100 / 4"	150 / 6"	200 / 8"	250 / 10"	300 / 12"
DN 2	80 / 3"	100 / 4"	150 / 6"	200 / 8"	250 / 10"	300 / 12"	350 / 14"
a	395 / 15.55	445 / 17.52	565 / 22.24	770 / 30.31	895 / 35.24	1010 / 39.76	1010 / 39.76
b	400 / 15.74	485 / 19.09	550 / 21.65	655 / 25.79	775 / 30.51	875 / 34.45	885 / 34.45
c	140 / 5.51	143 / 5.63	165 / 6.50	216 / 8.50	267 / 10.51	305 / 12.01	305 / 12.01
d	255 / 10.04	308 / 12.13	355 / 13.98	417 / 16.42	505 / 19.88	582 / 22.91	603 / 23.74
e	165 / 6.50	192 / 7.56	240 / 9.45	350 / 13.78	390 / 15.35	460 / 18.11	460 / 18.11

Dimensions of pressure and vacuum relief valves with heating jacket upon request

Table 2: Material selection for housing

Desing	A	B	C	
Housing	Aluminium	Steel	Stainless Steel	Option: Housing with ECTFE-lining
Heating jacket (VD/SV-PA(L)-H-...)	-	Steel	Stainless Steel	
Valve seat	Stainless Steel	Stainless Steel	Stainless Steel	Special materials upon request
Sealing	PTFE	PTFE	PTFE	

Table 3: Material selection for pressure valve pallet

Design	A	B	C	D	E	F
Pressure range (mbar) (inch W.C.)	+2.0 up to +3.5 +0.8 up to +1.4	>+3.5 up to +14 >+1.4 up to +5.6	>+14 up to +35 >+5.6 up to +14	>+35 up to +60 >+14 up to +24	>+14 up to +35 >+5.6 up to +14	>+35 up to +60 >+14 up to +24
Valve pallet	Aluminium	Stainless Steel	Stainless Steel	Stainless Steel	Stainless Steel	Stainless Steel
Sealing	FEP	FEP	Metal to Metal	Metal to Metal	PTFE	PTFE

Special material (alu-coated, titan, hastelloy) as well as higher set pressure upon request

Table 4: Material selection for vacuum valve pallet

Design	A	B	C	D	E	F
Vacuum range (mbar) (inch W.C.)	-2.0 up to -3.5 -0.8 up to -1.4	<-3.5 up to -14 <-1.4 up to -5.6	<-14 up to -35 <-5.6 up to -14	<-35 up to -60 <-14 up to -24	<-14 up to +35 <-5.6 up to +14	<-35 up to -60 <-14 up to -24
Valve pallet	Aluminium	Stainless Steel	Stainless Steel	Stainless Steel	Stainless Steel	Stainless Steel
Sealing	FEP	FEP	Metal to Metal	Metal to Metal	PTFE	PTFE

Special material (alu-coated, titan, hastelloy) as well as higher set vacuum upon request

Table 5: Flange connection type

EN 1092-1; Form B1	other types upon request
ASME B16.5; 150 lbs RF5F	



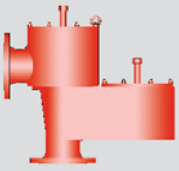

Pressure and Vacuum Relief Valve

Flow Capacity Charts

PROTEGO® VD/SV-PA(L)

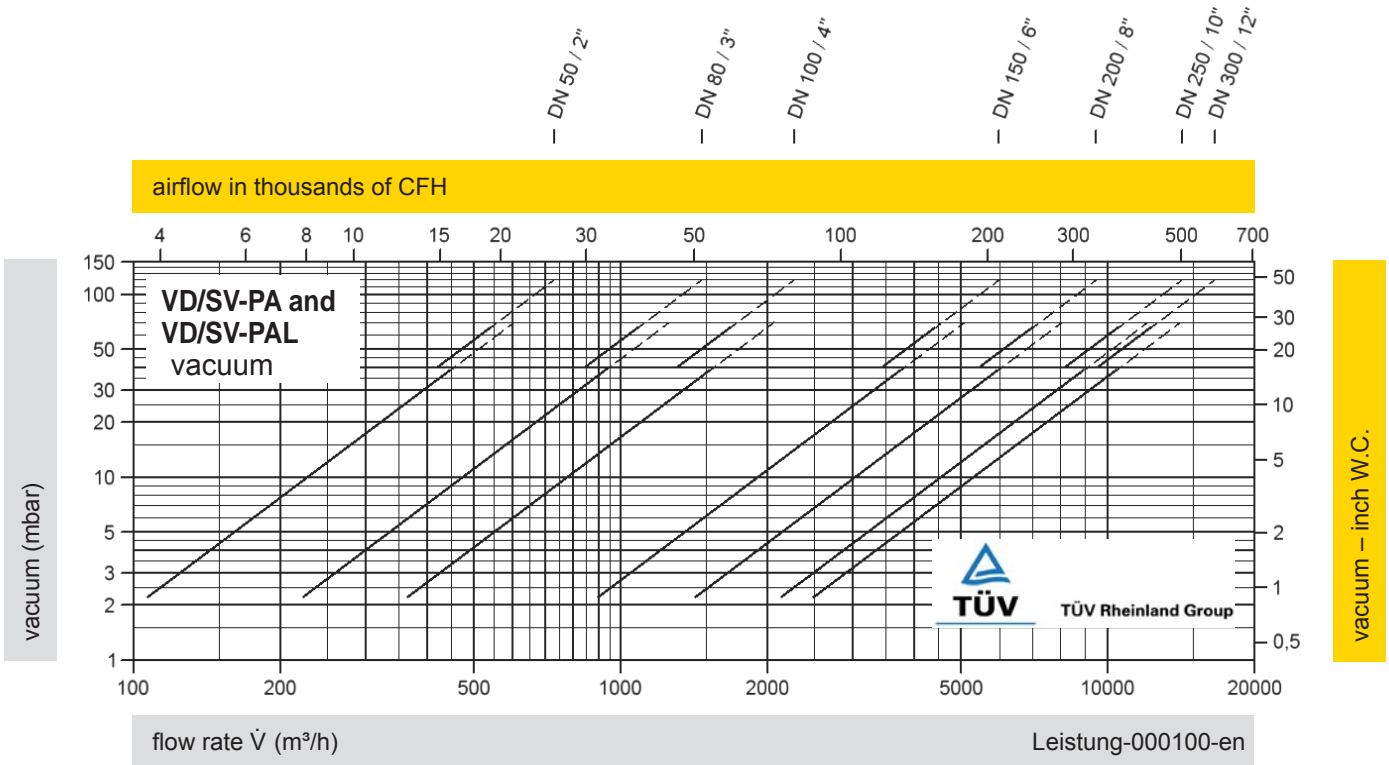

The flow capacity charts have been determined with a calibrated and TÜV certified flow capacity test rig. Volume flow \dot{V} in (m^3/h) and CFH refer to the standard reference conditions of air ISO 6358 (20°C, 1bar). Conversion to other densities and temperatures refer to Vol. 1: "Technical Fundamentals".

PROTEGO® VD/SV-PA(L)

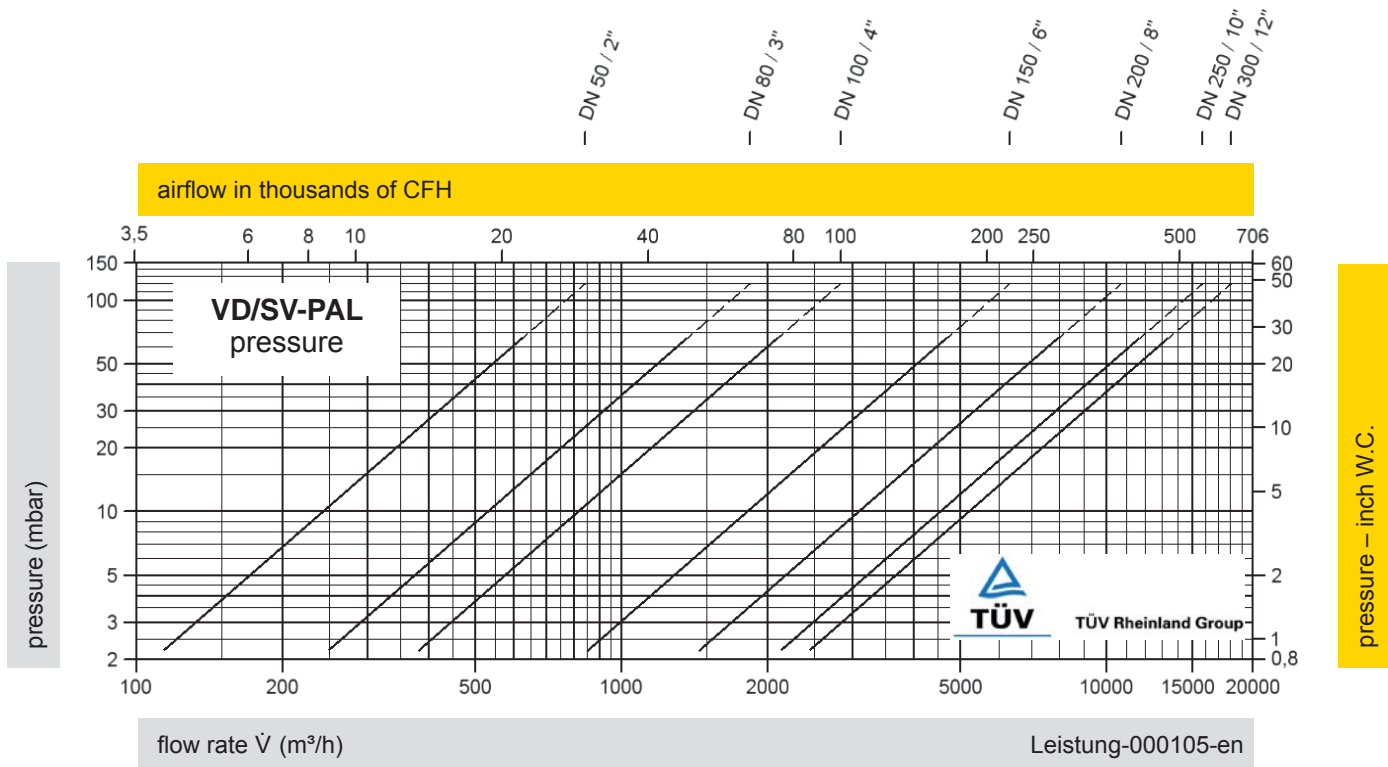
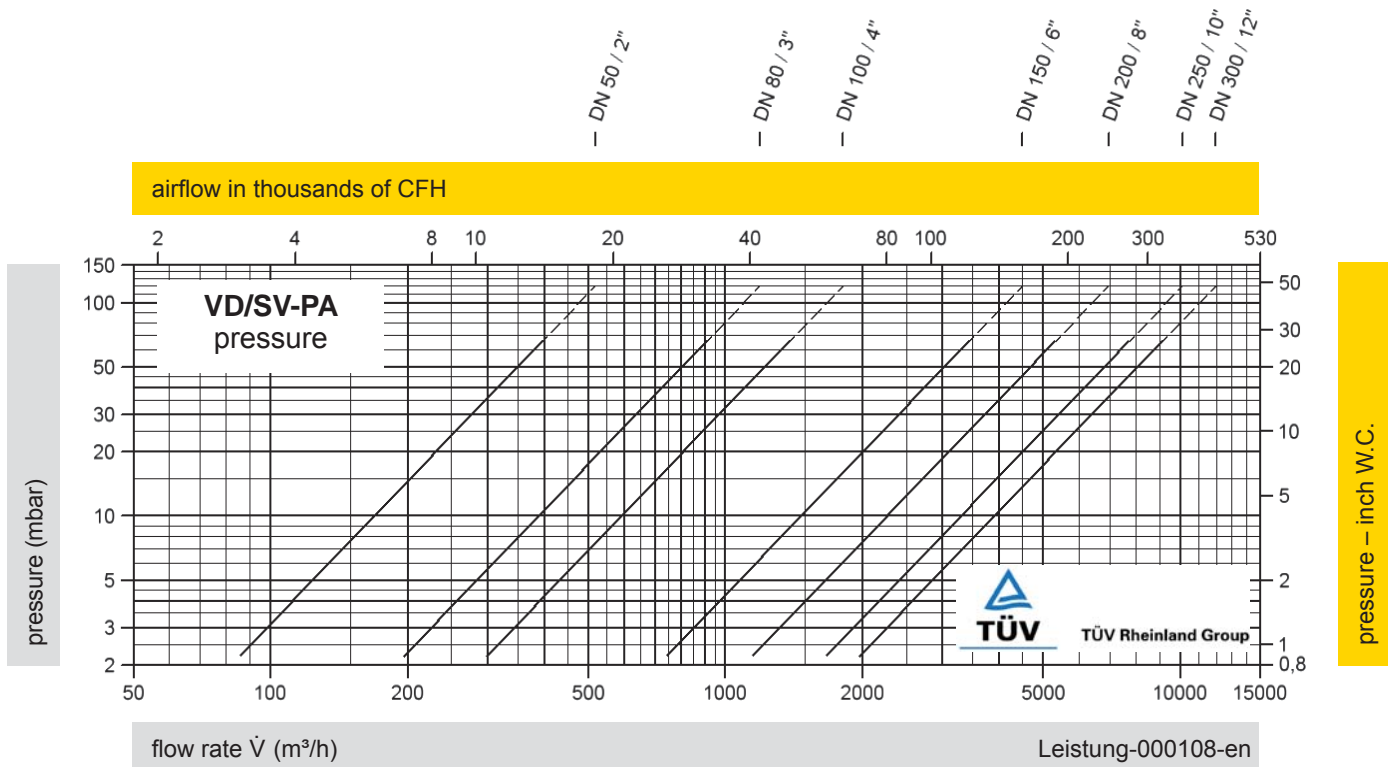

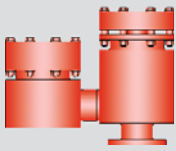

Pressure and Vacuum Relief Valve

made of plastic

PROTEGO® VD/KSM

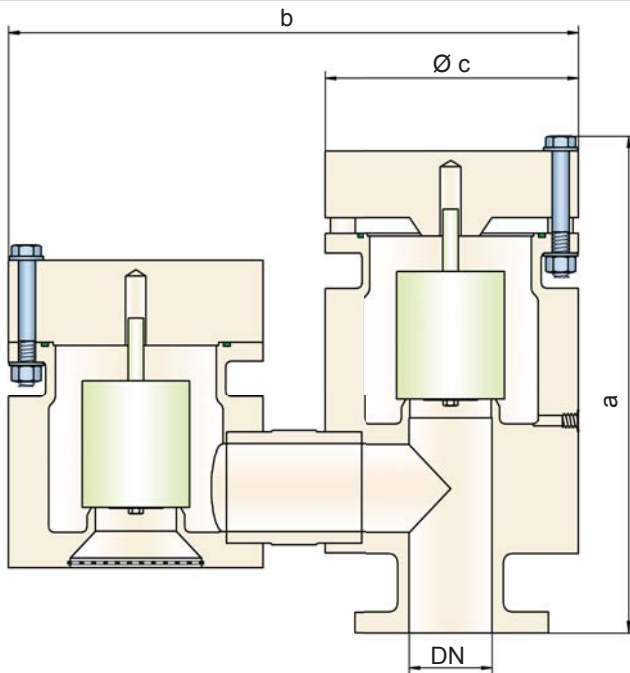

Settings:

Pressure:

+6.0 mbar	up to	+100 mbar (DN 50/2")
+2.4 inch W.C.	up to	+40 inch W.C.
+4.0 mbar	up to	+100 mbar (DN 80/3")
+1.6 inch W.C.	up to	+40 inch W.C.
+4.5 mbar	up to	+100 mbar (DN 100/4" - DN 200/8")
+1.8 inch W.C.	up to	+40 inch W.C.

Vacuum:

-6.0 mbar	up to	-100 mbar (DN 50/2")
-2.4 inch W.C.	up to	-40 inch W.C.
-4.0 mbar	up to	-100 mbar (DN 80/3")
-1.6 inch W.C.	up to	-40 inch W.C.
-4.5 mbar	up to	-100 mbar (DN 100/4" - DN 200/8")
-1.8 inch W.C.	up to	-40 inch W.C.

Higher and lower settings upon request

Function and Description

The PROTEGO® valve VD/KSM is a state-of-the-art pressure and vacuum relief valve with excellent flow performance made of highgrade synthetic material. Typically the valve is installed in the in- and out-breathing lines of tanks, vessels and process apparatus to protect against unallowable high or low pressure. The valve prevents emission losses almost up to the set pressure. The valve is a perfect solution for corrosive, polymerizing or sticky media.

The device will start to open as soon as the set pressure is reached and only requires 10% overpressure to full lift. Continuous investments into research and development have allowed PROTEGO® to develop a low pressure valve which has the same opening characteristic as a high pressure safety relief valve. This "full lift type" technology allows the valve to be set just 10% below the maximum allowable working pressure and vacuum (MAWP and MAWV) of the tank and still safely vent the required mass flow. The opening characteristic for pressure and vacuum side is the same.

Due to our highly developed manufacturing technology the tank pressure is maintained up to set pressure with a tightness that is far superior to the conventional standard. This feature is achieved by special valve seats made of high quality synthetic material or PTFE. After the excess pressure is discharged or vacuum is compensated, the valve reseats and provides a tight seal.

The optimized fluid dynamic design of the valve body and valve pallet is a result of many years of research work, which allow a stable operation of the valve pallet and optimized performance resulting in reduction of product losses.

Special Features and Advantages

- "full lift type" technology valve utilizes only 10% overpressure to reach full lift
- extreme tightness and hence least possible product losses and reduced environmental pollution
- the set pressure is close to the opening pressure which results in best possible pressure management of the system
- the valve pallet is guided within the housing to protect against harsh weather conditions
- corrosion resistant valve
- perfect solution for corrosive, polymerizing and sticky media
- weight reduction in comparison to steel/stainless steel
- vacuum side self draining and pressure side condensate drain
- smooth surface
- different plastics can be combined
- maintenance friendly design

Design Types and Specifications

The valve pallets are weight-loaded, and the highest pressure levels are only attained with metal discs.

Pressure/vacuum valve in basic design **VD/KSM-**

Additional special devices available upon request.



Vents for corrosive vapor service
(Flyer pdf)



Vents - 10% Technology
(Flyer pdf)



Leak Rate/10% Technology
(Flyer pdf)

Table 1: Dimensions

Dimensions in mm / inches

To select the nominal size (DN), use the flow capacity chart on the following page

DN	50 / 2"	80 / 3"	100 / 4"	150 / 6"	200 / 8"
a	376 / 14.80	521 / 20.51	563 / 22.17 (542 / 21.34)*	670 / 26.38 (681 / 26.81)*	917 / 36.10 (952 / 37.48)*
b	430 / 16.93	575 / 22.64	700 / 27.56 (675 / 26.57)*	825 / 32.48 (880 / 34.65)*	1190 / 46.85 (1100 / 43.31)*
c	180 / 7.09	250 / 9.84	300 / 11.81	350 / 13.78 (405 / 15.94)*	560 / 22.05 (500 / 19.68)*

* Dimensions in brackets only for PVDF

Table 2: Material selection for the housing

Design	A	B	C	
Housing	PE	PP	PVDF	Special Materials upon request
Valve seat	PE	PP	PVDF	
Sealing	FPM	FPM	FPM	
Pressure valve pallet	A, C, D	B, C, D	C, D	
Vacuum valve pallet	A, C, D	B, C, D	C, D	

Table 3: Material selection for pressure valve pallet

Design	A	B	C	D
Pressure range (mbar) (inch W.C.)	+6.0 up to +16 +2.4 up to +6.4	+5.5 up to +16 +2.2 up to +6.4	+9.5 up to +30 +3.8 up to +12	+30 up to +100 +12 up to +40
Valve pallet	PE	PP	PVDF	Hastelloy
Sealing	PTFE	PTFE	PTFE	PTFE
Spindle guide	PE	PP	PVDF	Hastelloy
Weight	PE	PP	PVDF	Hastelloy

Special materials and other pressure settings are available upon request

Table 4: Material selection for vacuum valve pallet

Design	A	B	C	D
Vacuum range (mbar) (inch W.C.)	-6.0 up to -16 -2.4 up to -6.4	-5.5 up to -16 -2.2 up to -6.4	-9.5 up to -30 -3.8 up to -12	-30 up to -100 -12 up to -40
Valve pallet	PE	PP	PVDF	Hastelloy
Sealing	PTFE	PTFE	PTFE	PTFE
Spindle guide	PE	PP	PVDF	Hastelloy
Weight	PE	PP	PVDF	Hastelloy

Special materials and other vacuum settings are available upon request

Table 5: Flange connection type

EN 1092-1; Form A	other types upon request
ASME B16.5; 150 lbs FF5F	



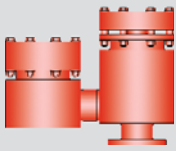

Pressure and Vacuum Relief Valve

Flow Capacity Charts

PROTEGO® VD/KSM

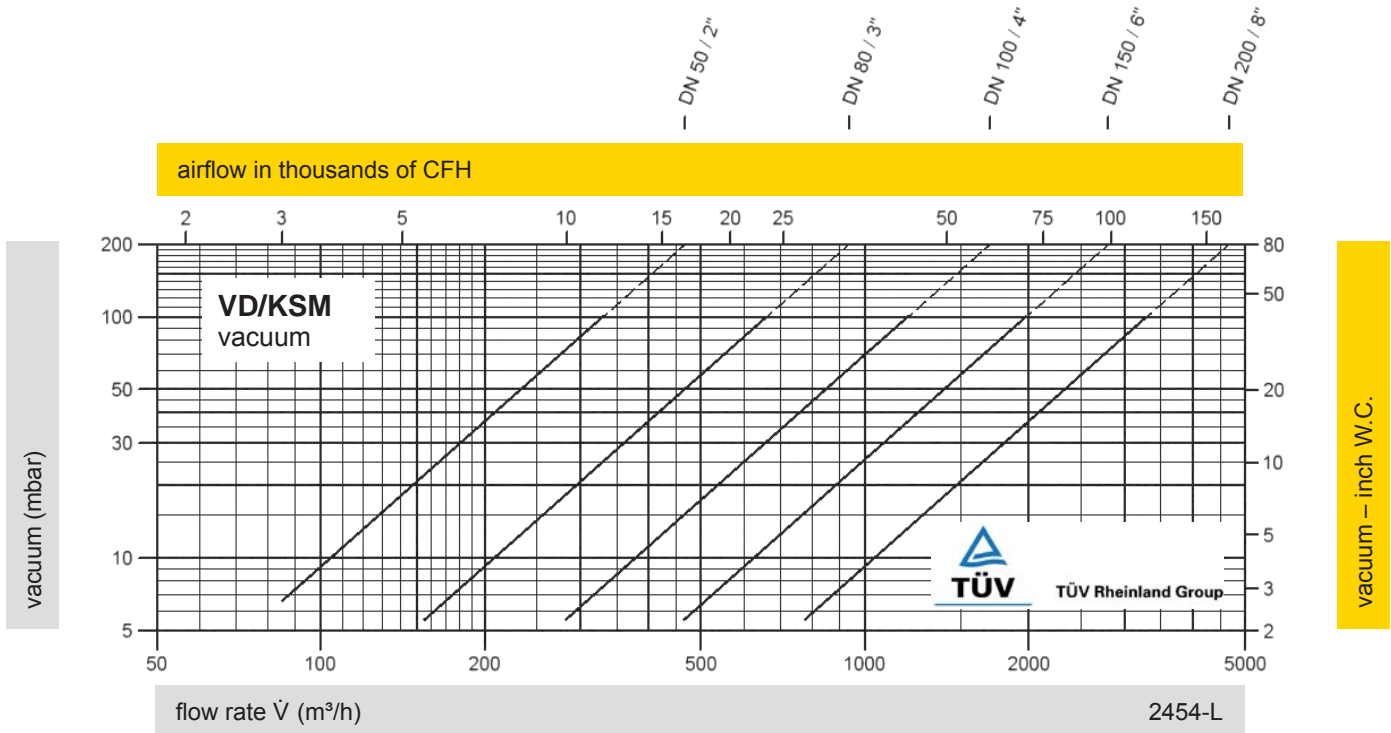
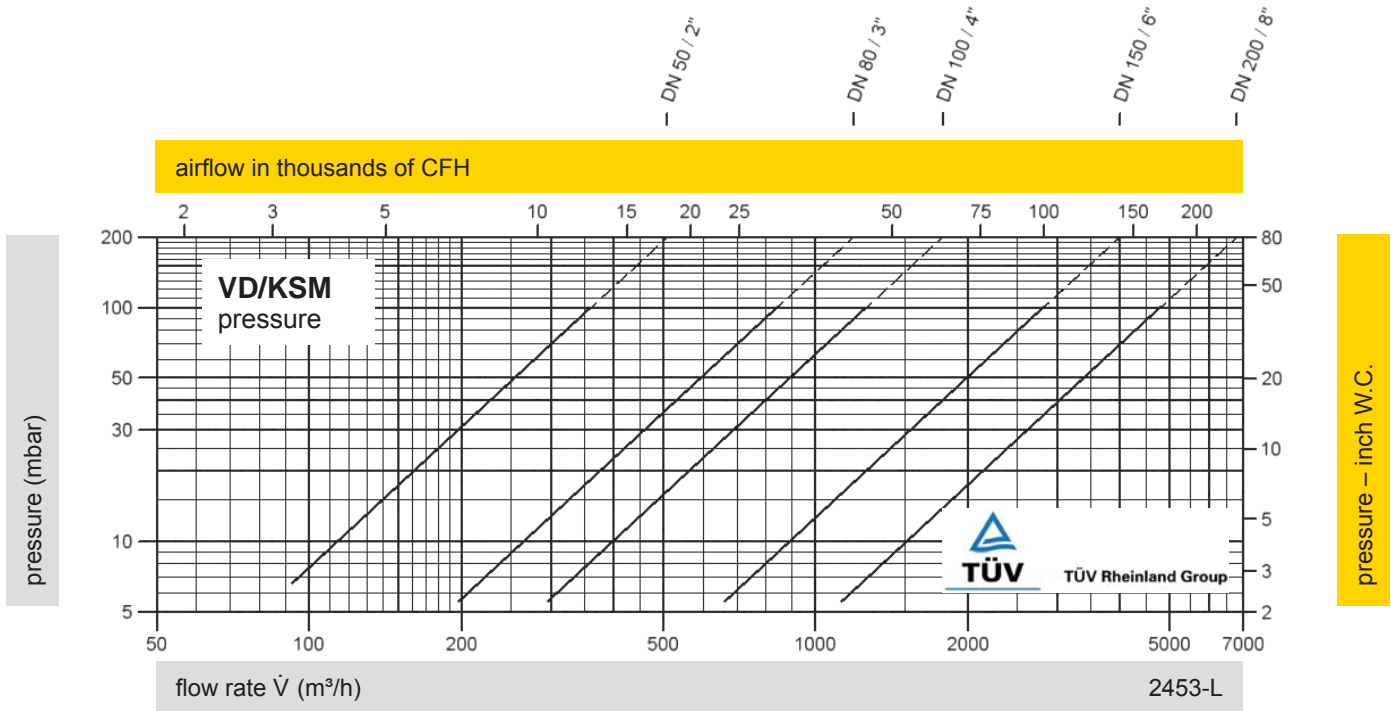

The flow capacity charts have been determined with a calibrated and TÜV certified flow capacity test rig. Volume flow \dot{V} in (m³/h) and CFH refer to the standard reference conditions of air ISO 6358 (20°C, 1bar). Conversion to other densities and temperatures refer to Vol. 1: "Technical Fundamentals".

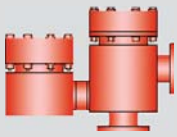

Pressure and Vacuum Relief Valve

made of plastic

PROTEGO® VD/KSM-PA

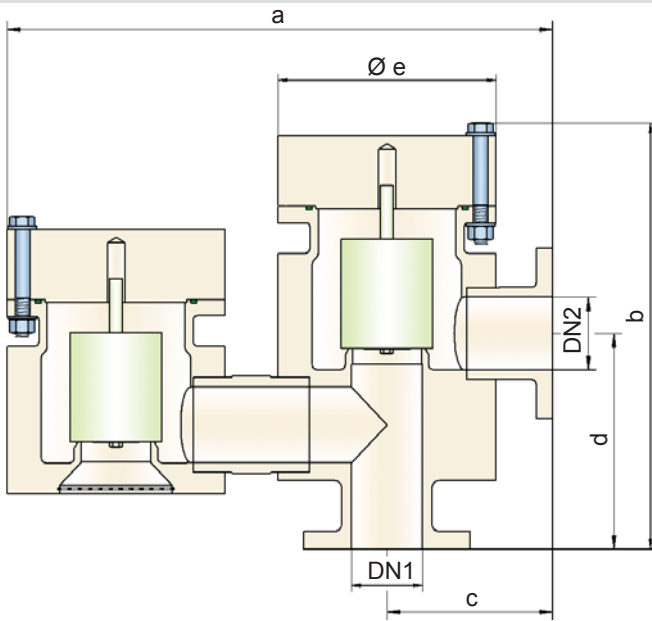

Settings:

Pressure:

+6.0 mbar	up to	+100 mbar (DN 50/2")
+2.4 inch W.C.	up to	+40 inch W.C.
+4.0 mbar	up to	+100 mbar (DN 80/3")
+1.6 inch W.C.	up to	+40 inch W.C.
+4.5 mbar	up to	+100 mbar (DN 100/4" - DN 200/8")
+1.8 inch W.C.	up to	+40 inch W.C.

Vacuum:

-6.0 mbar	up to	-100 mbar (DN 50/2")
-2.4 inch W.C.	up to	-40 inch W.C.
-4.0 mbar	up to	-100 mbar (DN 80/3")
-1.6 inch W.C.	up to	-40 inch W.C.
-4.5 mbar	up to	-100 mbar (DN 100/4" - DN 200/8")
-1.8 inch W.C.	up to	-40 inch W.C.

Higher and lower settings upon request

Function and Description

The PROTEGO® valve VD/KSM-PA is a state-of-the-art pressure and vacuum relief valve with excellent flow performance made of highgrade synthetic material. Typically the valve is installed in the in- and out-breathing lines of tanks, vessels and process apparatus to protect against unallowable high or low pressure. The valve prevents emission losses almost up to the set pressure. The valve is a perfect solution for corrosive, polymerizing or sticky media.

The device will start to open as soon as the set pressure is reached and only requires 10% overpressure to full lift. Continuous investments into research and development have allowed PROTEGO® to develop a low pressure valve which has the same opening characteristic as a high pressure safety relief valve. This "full lift type" technology allows the valve to be set just 10% below the maximum allowable working pressure and vacuum (MAWP and MAWV) of the tank and still safely vent the required mass flow. The opening characteristic for pressure and vacuum side is the same.

Due to our highly developed manufacturing technology the tank pressure is maintained up to set pressure with a tightness that is far superior to the conventional standard. This feature is achieved by special valve seats made of high quality synthetic material or PTFE. After the excess pressure is discharged or vacuum is compensated, the valve reseats and provides a tight seal.

The optimized fluid dynamic design of the valve body and valve pallet is a result of many years of research work, which allow a stable operation of the valve pallet and optimized performance resulting in reduction of product losses.

Special Features and Advantages

- "full lift type" technology valve utilizes only 10% overpressure to reach full lift
- extreme tightness and hence least possible product losses and reduced environmental pollution
- the set pressure is close to the opening pressure which results in best possible pressure management of the system
- the valve pallet is guided within the housing to protect against harsh weather conditions
- corrosion resistant valve
- perfect solution for corrosive, polymerizing and sticky media
- weight reduction in comparison to steel/stainless steel
- vacuum side self draining and pressure side condensate drain
- smooth surface
- different plastics can be combined
- maintenance friendly design

Design Types and Specifications

The valve pallets are weight-loaded, and the highest pressure levels are only attained with metal discs.

Pressure/vacuum valve in basic design **VD/KSM-PA-**

Additional special devices available upon request.



Vents for corrosive vapor service
(Flyer pdf)



Vents - 10% Technology
(Flyer pdf)



Leak Rate/10% Technology
(Flyer pdf)

Table 1: Dimensions

Dimensions in mm / inches

To select the nominal size (DN), use the flow capacity chart on the following page

DN1	50 / 2"	80 / 3"	100 / 4"	150 / 6"	200 / 8"
DN2	50 / 2"	80 / 3"	100 / 4"	150 / 6"	200 / 8"
a	490 / 19.29	650 / 25.59	775 / 30.51 (750 / 29.53)*	930 / 36.61 (958 / 37.72)*	1260 / 49.61 (1200 / 47.24)*
b	376 / 14.80	521 / 20.51	563 / 22.17 (523 / 20.59)*	670 / 26.38 (651 / 25.63)*	879 / 34.61 (912 / 35.91)*
c	150 / 5.91	200 / 7.87	225 / 8.86	280 / 11.02	350 / 13.78
d	200 / 7.87	245 / 9.65	300 / 11.81	370 / 14.57	590 / 23.23 (650 / 25.59)*
e	180 / 7.09	250 / 9.84	300 / 11.81	350 / 13.78 (405 / 15.94)*	560 / 22.05 (500 / 19.68)*

* Dimensions in brackets only for PVDF

Table 2: Material selection for the housing

Design	A	B	C	
Housing	PE	PP	PVDF	Special Materials upon request
Valve seat	PE	PP	PVDF	
Sealing	FPM	FPM	FPM	
Pressure valve pallet	A, C, D	B, C, D	C, D	
Vacuum valve pallet	A, C, D	B, C, D	C, D	

Table 3: Material selection for pressure valve pallet

Design	A	B	C	D
Pressure range (mbar) (inch W.C.)	+6.0 up to +16 +2.4 up to +6.4	+5.5 up to +16 +2.2 up to +6.4	+9.5 up to +30 +3.8 up to +12	+30 up to +100 +12 up to +40
Valve pallet	PE	PP	PVDF	Hastelloy
Sealing	PTFE	PTFE	PTFE	PTFE
Spindle guide	PE	PP	PVDF	Hastelloy
Weight	PE	PP	PVDF	Hastelloy

Special materials and other pressure settings are available upon request

Table 4: Material selection for vacuum valve pallet

Design	A	B	C	D
Vacuum range (mbar) (inch W.C.)	-6.0 up to -16 -2.4 up to -6.4	-5.5 up to -16 -2.2 up to -6.4	-9.5 up to -30 -3.8 up to -12	-30 up to -100 -12 up to -40
Valve pallet	PE	PP	PVDF	Hastelloy
Sealing	PTFE	PTFE	PTFE	PTFE
Spindle guide	PE	PP	PVDF	Hastelloy
Weight	PE	PP	PVDF	Hastelloy

Special materials and other vacuum settings are available upon request

Table 5: Flange connection type

EN 1092-1; Form A	other types upon request
ASME B16.5; 150 lbs FFSF	

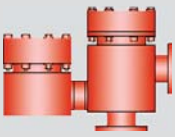

Pressure and Vacuum Relief Valve

Flow Capacity Charts

PROTEGO® VD/KSM-PA

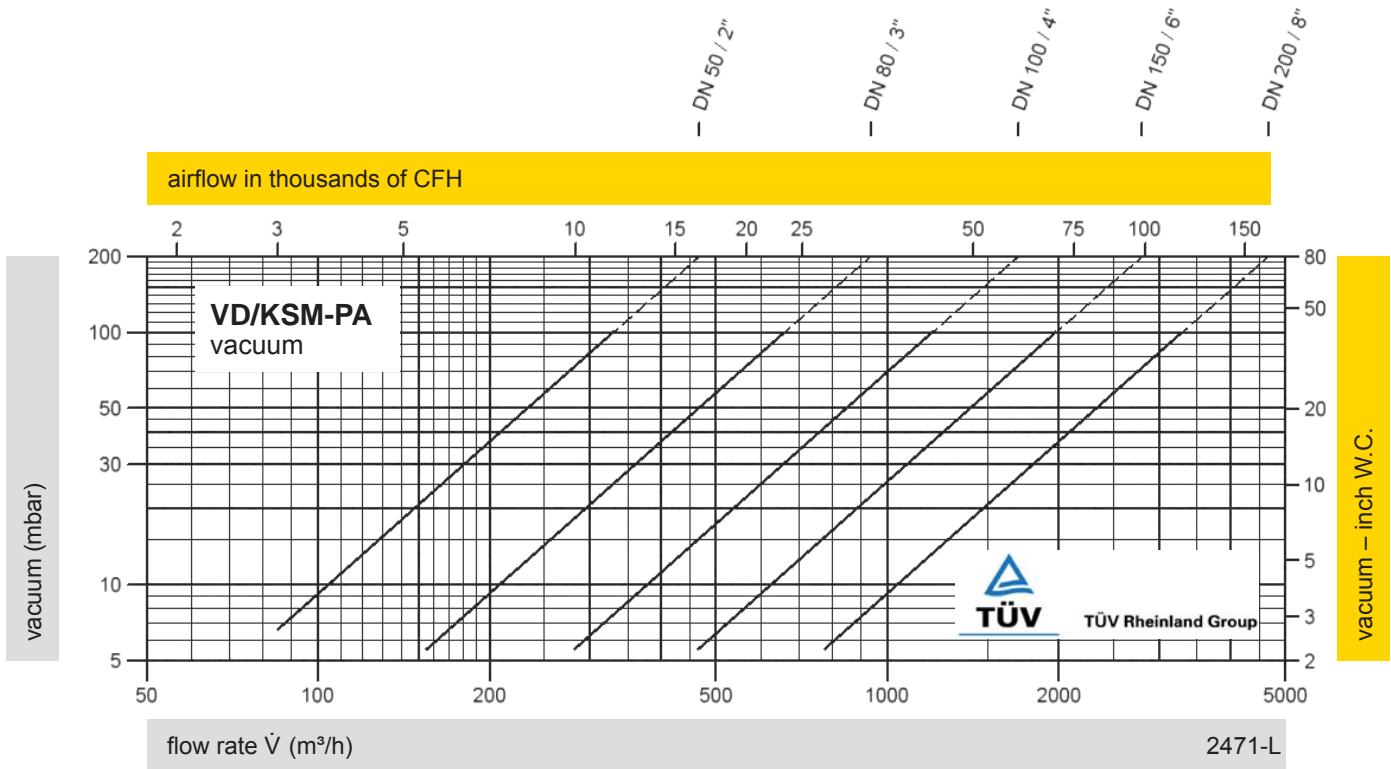
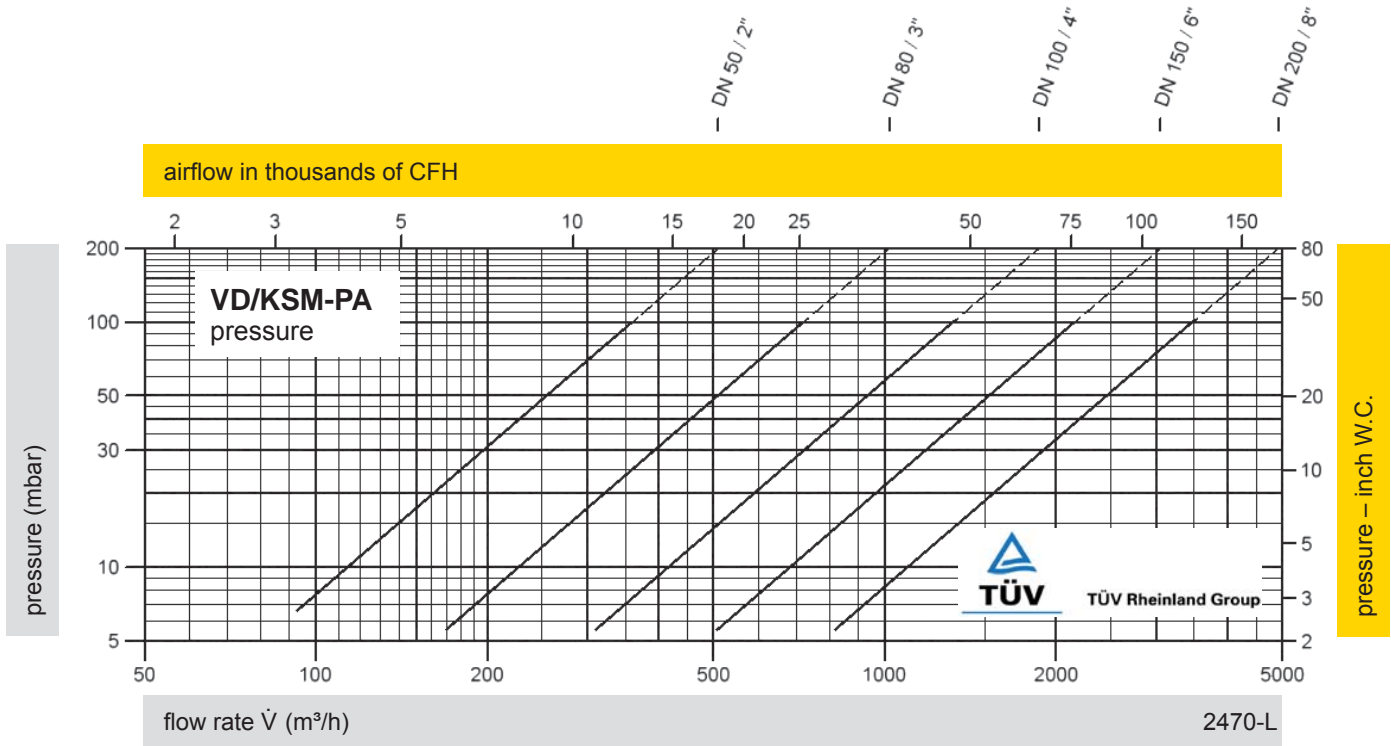

The flow capacity charts have been determined with a calibrated and TÜV certified flow capacity test rig. Volume flow \dot{V} in (m³/h) and CFH refer to the standard reference conditions of air ISO 6358 (20°C, 1bar). Conversion to other densities and temperatures refer to Vol. 1: "Technical Fundamentals".

www.protego.com



for safety and environment

PROTEGO® Pressure and Vacuum Relief Valves

in-line

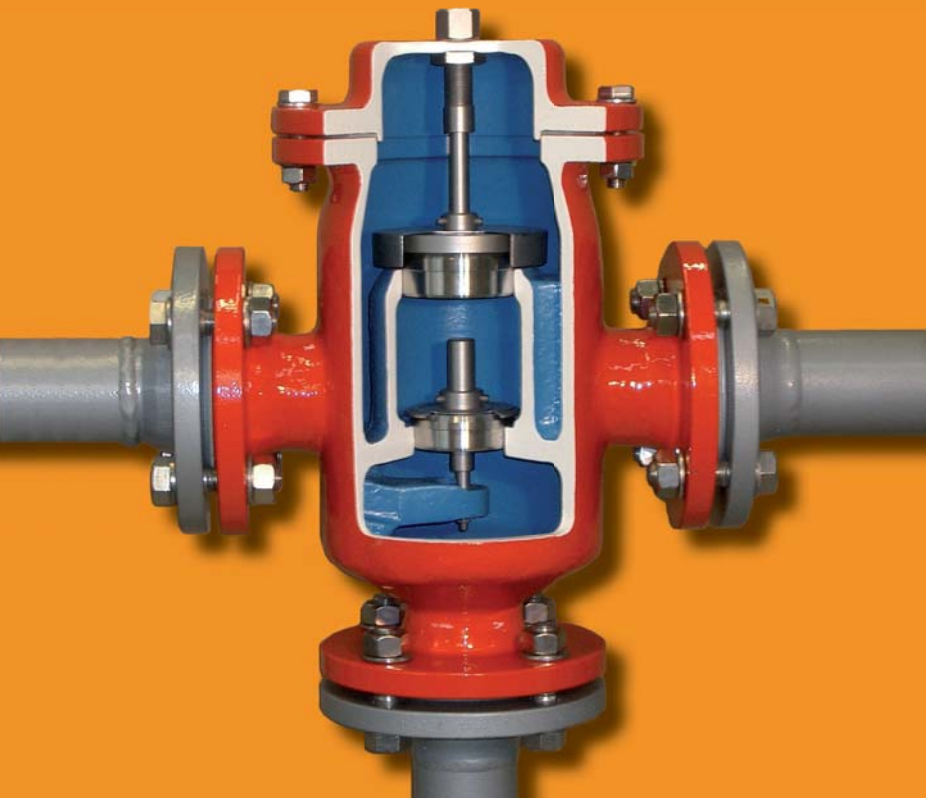

Volume 6

Volume 6



for safety and environment



The working principle and application of pressure and vacuum relief valves on tanks and process equipment is discussed in “Technical Fundamentals” (Volume 1). In this chapter we introduce in-line pressure and vacuum relief valves which can act in a pressure containing, relief or back flow protection function if installed on a tank or other process equipment.

Function and Description

These devices are direct acting weight or spring loaded in-line valves, pallet type, used to protect plant equipment (tanks, vessels, process technical apparatus, piping etc.) against unallowable operational high pressure or vacuum. In-line valves may also be installed as end-of-line valves. In end-of-line applications the open area to atmosphere has to be protected against weather impact, dirt particles or animals (Figure 1).

Figure 1:
Pressure and Vacuum Relief Valve
PROTEGO® DV/ZT

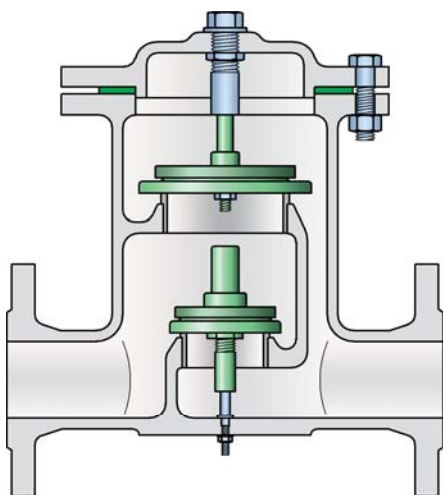

PROTEGO® pressure relief valves provide protection against unallowable high pressure and prevent emission losses almost up to set pressure.

PROTEGO® vacuum relief valves provide safety against unallowable low vacuum and prevent intake of air almost up to set vacuum.

Combined PROTEGO® pressure and vacuum relief valves fulfill both of these functions.

The design of the **PROTEGO®** valve pallets allows full lift to be reached at a maximum of 10% overpressure. This full lift type technology allows the valve to be set just 10% below the allowable fully open pressure (consider MAWP and possible pressure drop of piping and other devices) and still safely discharge the required mass flow. Typical overpressure for conventional valves is 40% to 100% (API 2000). These valves open earlier and reseal later which will result in undesirable product losses.

Special features and advantages

Continuous investment in research and development has allowed PROTEGO® to design valve pallets with the following advantages:

- 10% full lift type technology results in product saving (reduction of breathing losses can be more than 30%)
- PROTEGO® valves open later and reseal earlier, thus providing optimized pressure management and additional saving of inert/blanketing gases
- high flow performance allows cost reduction as smaller sized valves can be installed
- tightness superior to the required national and international standards
- the valve pallet is guided within the housing to protect against harsh weather conditions, e.g. preventing freezing of pallet in cold weather conditions
- can be installed in explosion hazardous areas
- maintenance friendly design

To reduce leak rates to a minimum and fulfill the highest expectation of the industry the valve seats and valve pallets are manufactured from high quality stainless steel and lapped in a highly developed manufacturing process. For low pressure settings valve pallets are equipped with high quality FEP-diaphragm.

Preferred applications

- as pressure containment valve e.g. for blanketing systems
- as pressure reducing valve e.g. to connect to nitrogen blanketing systems
- for controlled venting of plant or storage tanks into a vapour header system
- as back flow protection device in exhaust or inerting systems

Installation and servicing

All PROTEGO® devices are delivered with detailed installation and maintenance manuals. Please take notice of the instructions for the removal of the transport protection, if applicable. The special check lists should be followed to ensure the correct installation of the PROTEGO® devices.

Selection

For safely operating and protecting the plant the correct selection and sizing of the PROTEGO® device is necessary. The valves are mainly characterized by the following criteria:

Function: Pressure relief, vacuum relief or combined pressure and vacuum relief

Working principle: Weight or spring loaded valve pallet, depending on set pressure

Design type: Right angle or straight through design, horizontal or vertical connection to the protected object. The devices are spring or weight loaded and therefore have to be installed with the valve pallets in horizontal position. The maximum and minimum pressure settings depend on the specific design.

Sealing: Depending on the set pressures either metal sealing or soft sealing provide an extremely tight seal.

Operating conditions and critical medium: Polymerisation problems, condensation problems, operating temperature, operating pressure, volume flow are the main criteria for choosing the correct devices.

Depending on the application, it may be important to select a device with a **heating jacket**, but please note that not all devices are available with this feature. Electrical trace heating may be an alternative.

Sizing

The **valve size** results from the volume flow which has to be vented to avoid an increase above the maximum allowable pressure or vacuum. Certified volume flow diagrams are used for sizing. For correct sizing the operating conditions and the pressure drops of the piping system (including other installed devices) and superimposed backpressures have to be taken into account.

Detailed procedures and examples for sizing are described in "Technical Fundamentals" (see Volume 1).

Example 1

Given: Volume flow \dot{V}_{max} in m³/h / CFH (e.g. for in- or out breathing of a storage tank this is the sum of the pump capacity and the thermal breathing requirement) and maximum allowable opening pressure (e.g. tank pressure) p in mbar / inch W.C.

Required: Valve size DN

Procedure: The intersection point of \dot{V}_{max} and p_T determines the required valve size. Opening pressure = the maximum allowable tank pressure. The volume flow diagrams show the volume flow as function of the opening pressure for a fully open valve.

The set pressure of the valve has to be determined so that the calculated volume flow can safely be discharged. For a valve which needs 10% overpressure to reach full lift the set pressure may be chosen 10% below the fully open pressure (e.g. maximum allowable tank pressure). Attention: pressure drop of piping systems and other installed devices have to be considered!

Many conventional valves need 100% overpressure to reach full lift. In these cases the set pressure may be just half of the maximum allowable tank pressure. Consequently these valves open earlier and avoidable product losses occur.

Example 2

Alternatively the valve performance has to be checked if the size and maximum allowable pressure are provided.

Given: Connection nozzle size and maximum allowable opening pressure (e.g. Tank pressure) p in mbar / inch W.C.

Required: Volume flow in m³/h / CFH, set pressure p_A in mbar / inch W.C.

Procedure: From the intersection point of the straight line of p and the valve performance curve of the specific valve size the volume flow \dot{V}_{max} is determined. The volume flow of the set pressure p_A may be 10%, (PROTEGO®-technology) or 40% or 100% below the opening pressure p_T . Attention: pressure drop of piping systems and other installed devices have to be considered!

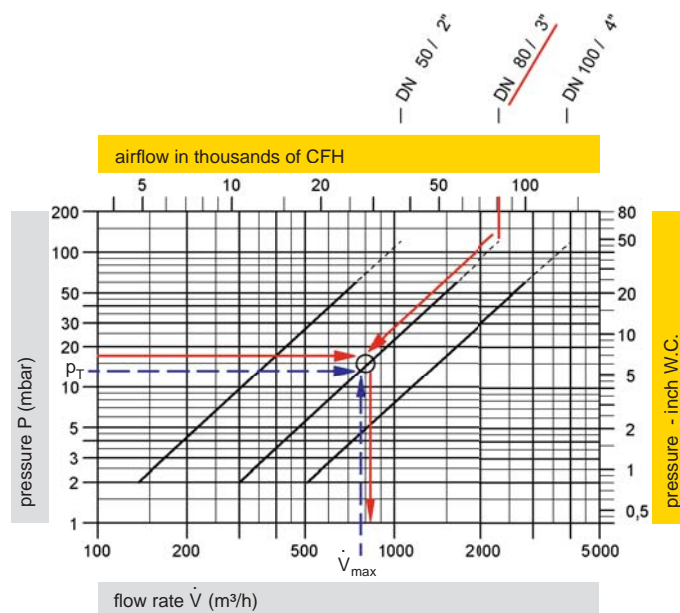

The required set pressure (= start of opening) will be the opening pressure (valve fully open) minus the characteristic overpressure.

For PROTEGO® valves and end of line devices the overpressure characteristic is 10% unless otherwise stated. Within 10% overpressure the valve pallet will reach full lift. A further increase in flow performance will follow the pressure volume flow diagram.

Material selection is based on plant and engineering specifications.

Guidelines for calculating the volume flow and considering the density influence are given in „Technical Fundamentals“ (see Volume 1).







After completing all steps the device can be completely specified and ordered.

To enable us to provide a quotation we recommend completing the data sheet from Vol.1 with the specific process data.

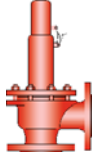

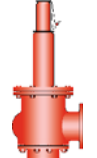

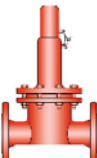
PROTEGO® Pressure and Vacuum Relief Valves – in-line

	Type	Size	Pressure setting positive or negative setting range mbar / inch W.C.	O = weight loaded X = spring loaded	Design O = straight through design X = right angle design	O = soft sealing X = metallic sealing	O = for critical medium (polymerisation, corrosion, crystallisation)	O = heating jacket	Page
Pressure or Vacuum Relief Valves									
	DZ/E	25 - 300 1" - 12"	±2.0 up to ±60 ±0.8 up to ±24	O	X	O / X		O	230 - 232
	DZ/E-F	25 - 300 1" - 12"	±60 up to ±500 ±24 up to ±200	X	X	X		O	234 - 236
	DZ/EA	50 - 150 2" - 6"	±5 up to ±50 ±2 up to ±20	O	X	X	O		238- 239
	DZ/EA-F	50 - 150 2" - 6"	±60 up to ±500 ±24 up to ±200	X	X	X	O		240 - 242
	DZ/T	25 - 300 1" - 12"	±2.0 up to ±60 ±0.8 up to ±24	O	O	O / X		O	244 - 246
	DZ/T-F	25 - 300 1" - 12"	±60 up to ±500 ±24 up to ±200	X	O	X		O	248 - 250
	R/KSM	50 - 200 2" - 8"	±5 up to ±100 ±2 up to ±40	O	X	O			252 - 253

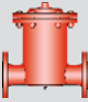
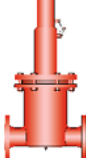
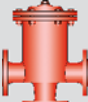
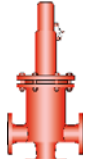
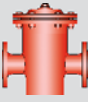
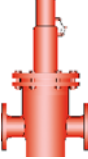
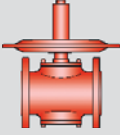
	Type	Size	Pressure setting		O = weight loaded X = spring loaded	Design O = straight through design X = right angle design	O = soft sealing X = metallic sealing	O = for critical medium (polymerisation, corrosion, crystallisation)	O = heating jacket	Page
			positive setting range mbar / inch W.C.	negative setting range mbar / inch W.C.						
Pressure and Vacuum Relief Valves										
	DV/ZT	40 - 150 1½" - 6"	upper valve pallet ±2.0 up to ±60 ±0.8 up to ±24	lower valve pallet ±3.5 up to ±50 ±1.4 up to ±20	O	O	O / X		O	254 - 256
	DV/ZT-F	40 - 150 1½" - 6"	+60 up to +500 +24 up to +200	-3.5 up to -50 -1.4 up to -20	X	O	X		O	258 - 260
	DV/ZU	40 - 150 1½" - 6"	+2.0 up to +60 +0.8 up to +24	-3.5 up to -50 -1.4 up to -20	O	O / X	O / X		O	262 - 264
	DV/ZU-F	40 - 150 1½" - 6"	+60 up to +500 +24 up to +200	-3.5 up to -50 -1.4 up to -20	X	O / X	X		O	266 - 268
	DV/ZW	40 - 150 1½" - 6"	+2.0 up to +60 +0.8 up to +24	-3.5 up to -50 -1.4 up to -20	O	O	O / X		O	270 - 272
	DV/ZW-F	40 - 150 1½" - 6"	+60 up to +500 +24 up to +200	-3.5 up to -50 -1.4 up to -20	X	O	X		O	274 - 276
Blanketing Valve										
	ZM-R	15 - 100 ½" - 4"	up to +500 up to +200	up to -200 up to -80	X	O	O			278 - 283



for safety and environment

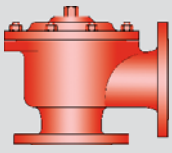

Pressure or Vacuum Relief Valve, In-Line

PROTEGO® DZ/E

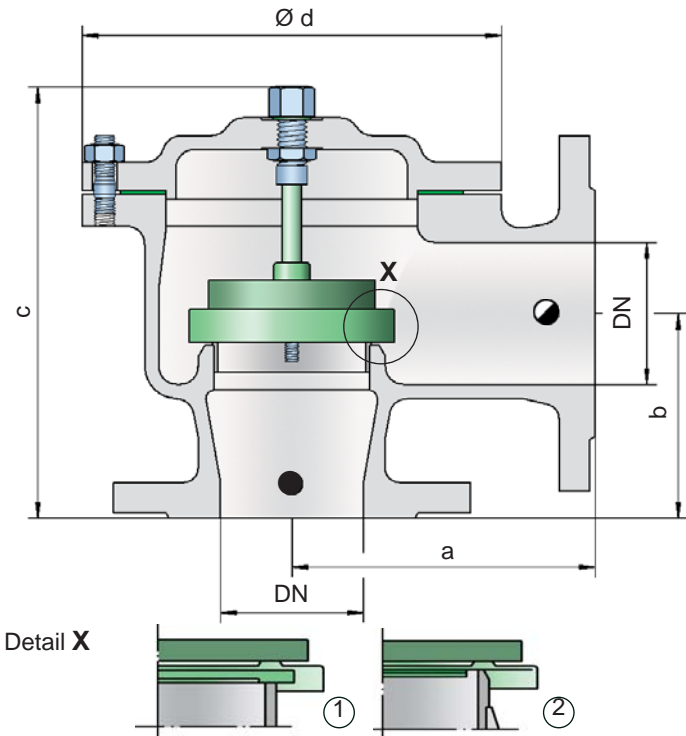

● = Tank connection for pressure relief function

◐ = Tank connection for vacuum relief function

Flow direction marked at the housing by →

Pressure or vacuum settings:

DN 25 and 32	±3.5 mbar	up to ±60 mbar
DN 1" and 1½"	±1.4 inch W.C.	up to ±24 inch W.C.
DN 40	up to 300 ±2.0 mbar	up to ±60 mbar
DN 1½" up to 12"	± 0.8 inch W.C.	up to ±24 inch W.C.

For higher set pressure or vacuum refer to type DZ/E-F

Function and Description

The PROTEGO® in-line valve DZ/E is a state-of-the-art pressure or vacuum relief valve in right angle design. Typically the valve is installed in the in- or outbreathing lines of tanks, vessels and process apparatus to protect against unallowable high or low pressure. The valve prevents emission losses almost up to the set pressure or provides protection from product entry into the system.

The device will start to open as soon as the set pressure is reached and only requires 10% overpressure to full lift. Continuous investments into research and development have allowed PROTEGO® to develop a low pressure valve which has the same opening characteristic as a high pressure safety relief valve. This "full lift type" technology allows the valve to be set just 10% below the maximum allowable working pressure or vacuum (MAWP or MAWV) of the tank and still safely vent the required mass flow. The opening characteristic is the same for pressure and vacuum relief. Due to our highly developed manufacturing technology the tank pressure is maintained up to

set pressure with a tightness that is far superior to the conventional standard. This feature is facilitated by valve seats made of high quality stainless steel and with individually lapped valve pallets (1) or with an air cushion seal (2) in conjunction with high quality FEP diaphragm. The valve pallets are also available with a PTFE seal to prevent the valve pallets from sticking when sticky products are used and to enable the use of corrosive fluids. After the excess pressure is discharged or the vacuum is compensated, the valve reseats and provides a tight seal.

The optimized fluid dynamic design of the valve body and valve pallet is a result of many years of research work, which allow a stable operation of the valve pallet and optimized performance resulting in reduction of product losses.

Special Features and Advantages

- "full lift type" technology valve utilizes only 10% overpressure to reach full lift
- high performance seal reducing product loss below EPA's 500ppm rule preventing environmental pollution
- based on 10% technology the set pressure is close to the opening pressure which results in best possible pressure management of the system compared to conventional 40%- or 100%- technology valves
- optimized flow performance, which reduces capital cost to a minimum as smaller sized valves may be used
- can be used as pressure or vacuum relief valve
- compact right angle design saves space
- can be installed in explosion hazardous areas
- housing designed to 150 psi (PN 10)
- maintenance friendly design

Designs and Specifications

The valve pallet is weight loaded. **Higher set pressures for pressure and vacuum are achieved by using spring loaded type DZ/E-F.**

Two different right angle designs are available:

In-line pressure or vacuum relief valve, standard design

DZ/E -

In-line pressure or vacuum relief valve with heating jacket

DZ/E -

Additional special devices available upon request

Within piping systems the influence of backpressure has to be considered in deciding the set pressure and opening characteristics. For special design solutions (e.g. partial load operation) the valve can be supplied with standard valve pallets (with proportional opening function).



Vents - 10% Technology
(Flyer pdf)



Leak Rate/10% Technology
(Flyer pdf)



Coated Devices
(Flyer pdf)



The optimised valve pallet
(Flyer pdf)

Table 1: Dimensions

Dimensions in mm / inches

To select the nominal size (DN), please use the flow capacity chart on the following page

DN	25 / 1"	32 / 1 ¼"	40 / 1 ½"	50 / 2"	80 / 3"	100 / 4"	150 / 6"	200 / 8"	250 / 10"	300 / 12"
a	110 / 4.33	110 / 4.33	125 / 4.92	125 / 4.92	170 / 6.69	190 / 7.48	230 / 9.06	275 / 10.83	325 / 12.80	350 / 13.78
b	75 / 2.95	75 / 2.95	90 / 3.54	90 / 3.54	115 / 4.53	120 / 4.72	160 / 6.30	225 / 8.86	275 / 10.83	300 / 11.81
c	180 / 7.09	180 / 7.09	230 / 9.06	230 / 9.06	245 / 9.65	260 / 10.24	335 / 13.19	505 / 19.88	575 / 22.64	630 / 24.80
d	150 / 5.91	150 / 5.91	170 / 6.69	170 / 6.69	235 / 9.25	280 / 11.02	335 / 13.19	420 / 16.54	505 / 19.88	565 / 22.24

Dimensions for pressure or vacuum relief valve with heating jacket upon request

Table 2: Material selection for housing

Design	A	B	C
Housing	Steel	Stainless Steel	Hastelloy
Heating jacket (DZ/E-H-...)	Steel	Stainless Steel	Stainless Steel
Valve seat	Stainless Steel	Stainless Steel	Hastelloy
Gasket	PTFE	PTFE	PTFE
Valve pallet DN 40 - 300 / 1 ½" - 12"	A, C, E, F	A, C, E, F	B, D, G
Valve pallet DN 25 - 32 / 1" - 1 ¼"	H, I, J	H, I, J	-

Option: Housing with ECTFE-lining
Special materials upon request

Table 3: Material selection for valve pallet

DN 40 - 300 / 1 ½" - 12"

Design	A	B	C	D	E	F	G
Pressure range (mbar) (inch W.C.)	±2.0 up to ±3.5 ±0.8 up to ±1.4	±2.0 up to ±3.5 ±0.8 up to ±1.4	±3.5 up to ±14 ±1.4 up to ±5.6	±3.5 up to ±14 ±1.4 up to ±5.6	±14 up to ±60 ±5.6 up to ±24	±14 up to ±60 ±5.6 up to ±24	±14 up to ±60 ±5.6 up to ±24
Valve pallet	Aluminium	Titanium	Stainless Steel	Titanium	Stainless Steel	Stainless Steel	Hastelloy
Sealing	FEP	FEP	FEP	FEP	Metal to Metal	PTFE	Metal to Metal

DN 25 - 32 / 1" - 1 ¼"

Design	H	I	J
Pressure range (mbar) (inch W.C.)	±3,5 up to ±15 ±1.4 up to ±6.0	±15 up to ±60 ±6.0 up to ±24	±15 up to ±60 ±6.0 up to ±24
Valve pallet	PTFE	Stainless Steel	Stainless Steel
Sealing	PTFE	Metal to Metal	PTFE

Special materials upon request

For higher set pressure or vacuum refer to type DZ/E-F

Table 4: Flange connection type

EN 1092-1; Form B1
ASME B16.5; 150 lbs RFSF

other types upon request



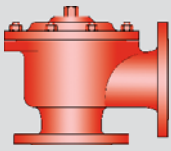

Pressure or Vacuum Relief Valve, In-Line

Flow Capacity Chart

PROTEGO® DZ/E

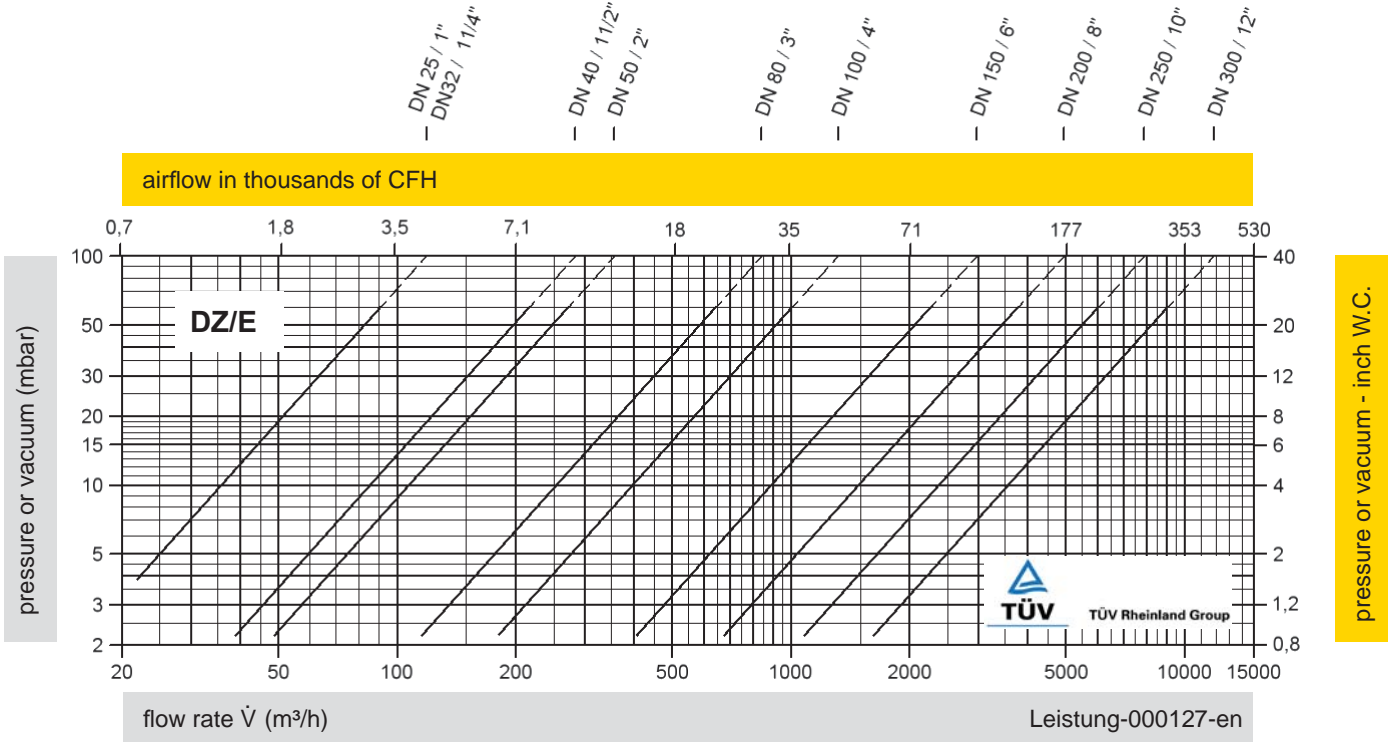

The flow capacity chart has been determined with a calibrated and TÜV certified flow capacity test rig.
 Volume flow \dot{V} in (m³/h) and CFH refer to the standard reference conditions of air ISO 6358 (20°C, 1bar).
 Conversion to other densities and temperatures refer to Technical Fundamentals.

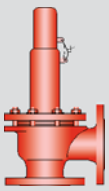

Pressure or Vacuum Relief Valve, In-Line



PROTEGO® DZ/E-F

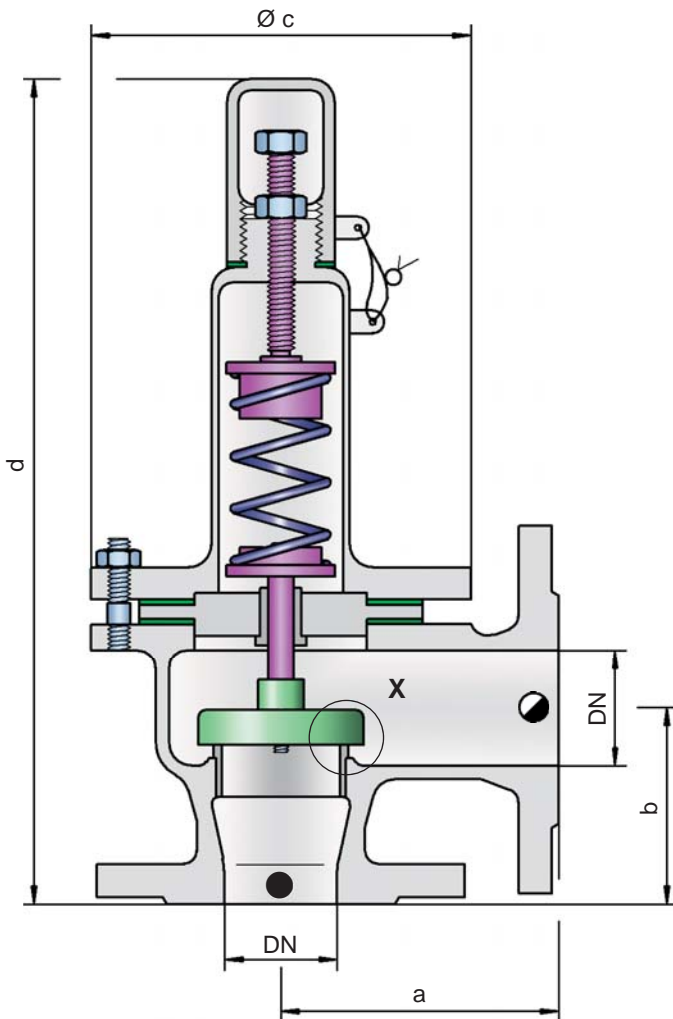

- = Tank connection for pressure relief function
- ◐ = Tank connection for vacuum relief function

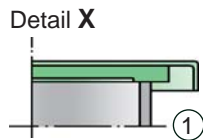

Flow direction marked at the housing by →

Pressure or vacuum settings:

±60 mbar	up to ±500 mbar (DN 25/1" up to 200/8")
±24 inch W.C.	up to ±200 inch W.C.
±60 mbar	up to ±400 mbar (DN 250/10")
±24 inch W.C.	up to ±160 inch W.C.
±60 mbar	up to ±300 mbar (DN 300/12")
±24 inch W.C.	up to ±120 inch W.C.

Devices with higher set pressure or vacuum are available upon request, for lower set pressures or vacuum refer to type DZ/E.

Function and Description

The PROTEGO® in-line valve DZ/E-F is a state-of-the-art pressure or vacuum relief valve in right angle design for higher system pressures. Typically the valve is installed in the in- or outbreathing lines of tanks, vessels and process apparatus to

protect against unallowable high or low pressure. The valve prevents emission losses almost up to the set pressure or provides protection from product entry into the system. As this device is equipped with a spring higher set pressures can be reached compared to the DZ/E.

The device will start to open as soon as the set pressure is reached and only requires 10% overpressure to full lift. Continuous investments into research and development have allowed PROTEGO® to develop a low pressure valve which has the same opening characteristic as a high pressure safety relief valve. This "full lift type" technology allows the valve to be set just 10% below the maximum allowable working pressure or vacuum (MAWP or MAWV) of the tank and still safely vent the required mass flow. The opening characteristic is the same for pressure and vacuum relief. Due to our highly developed manufacturing technology the tank pressure is maintained up to set pressure with a tightness that is far superior to the conventional standard. This feature is facilitated by valve seats made of high quality stainless steel and with individually lapped valve pallets (1) and a rugged valve body. After the excess pressure is discharged or vacuum is compensated, the valve reseats and provides a tight seal.

The optimized fluid dynamic design of the valve body and valve pallet is a result of many years of research work, which allow a stable operation of the valve pallet and optimized performance resulting in reduction of product losses.

Special Features and Advantages

- "full lift type" technology valve utilizes only 10% overpressure to reach full lift
- high performance seal reducing product loss below EPA's 500ppm rule preventing environmental pollution
- based on 10% technology the set pressure is close to the opening pressure which results in best possible pressure management of the system compared to conventional 40%- or 100%- technology valves
- optimized flow performance, which reduces capital cost to a minimum as smaller sized valves may be used
- can be used as pressure or vacuum relief valve
- compact right angle design saves space
- can be installed in explosion hazardous areas
- housing designed to 150 psi (PN 10)
- spring loaded for elevated set pressures
- maintenance friendly design



Vents - 10% Technology
(Flyer pdf)



Leak Rate/10% Technology
(Flyer pdf)



Coated Devices
(Flyer pdf)



The optimised valve pallet
(Flyer pdf)

Designs and Specifications

The valve pallet is spring loaded. Lower set pressures for pressure and vacuum are achieved by using the weight loaded type DZ/E.

Two different right angle designs are available:

In-line pressure or vacuum relief valve, standard design **DZ/E-F - □**

In-line pressure or vacuum relief valve with heating jacket **DZ/E-F - H**

Additional special devices available upon request.

Within piping systems the influence of backpressure has to be considered in deciding the set pressure and opening characteristics. For special design solutions (e.g. partial load operation) the valve can be supplied with standard valve pallets (with proportional opening function).



Spring-loaded PV-Valves
Maintenance-friendly design (Flyer pdf)

Table 1: Dimensions

Dimensions in mm / inches

To select the nominal size (DN), please use the flow capacity charts on the following pages

DN	25 / 1"	32 / 1 ¼"	40 / 1 ½"	50 / 2"	65 / 2 ½" / 80 / 3"	100 / 4"	150 / 6"	200 / 8"	250 / 10"	300 / 12"
a	110 / 4.33	110 / 4.33	125 / 4.92	125 / 4.92	170 / 6.69	190 / 7.48	230 / 9.06	275 / 10.83	325 / 12.80	350* / 13.78
b	75 / 2.95	75 / 2.95	90 / 3.54	90 / 3.54	115 / 4.53	120 / 4.72	160 / 6.30	225 / 8.86	275 / 10.83	300 / 11.81
c	150 / 5.91	150 / 5.91	170 / 6.69	170 / 6.69	235 / 9.25	280 / 11.02	335 / 13.19	420 / 16.54	505 / 19.88	565 / 22.24
d	435 / 17.13	435 / 17.13	445 / 17.52	445 / 17.52	620 / 24.41	700 / 27.56	970 / 38.19	1205 / 47.44	1275 / 52.36	1330 / 52.36

Dimensions for pressure or vacuum relief valve with heating jacket upon request

* for ANSI 12" = 400 mm / 15.75 inches

Table 2: Material selection for housing

Design	A	B	
Housing	Steel	Stainless Steel	Option: Housing with ECTFE-lining
Heating jacket (DZ/E-F-H-...)	Steel	Stainless Steel	
Valve seat	Stainless Steel	Stainless Steel	Special materials upon request
Gasket	PTFE	PTFE	
Valve pallet	A	A	

Table 3: Material of valve pallet

Design	A	
Pressure range (mbar) (inch W.C.)	±60 up to ±500 ±24 up to ±200	Special materials upon request
Valve pallet	Stainless Steel	Devices with higher set pressure or vacuum are available upon request, for lower set pressures or vacuum refer to type DZ/E.
Sealing	Metal to Metal	
Spring	Stainless Steel	

Table 4: Flange connection type

EN 1092-1; Form B1	other types upon request
ASME B16.5; 150 lbs RFSF	



for safety and environment

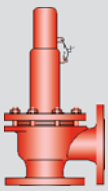

Pressure or Vacuum Relief Valve, In-Line

Flow Capacity Chart

PROTEGO® DZ/E-F

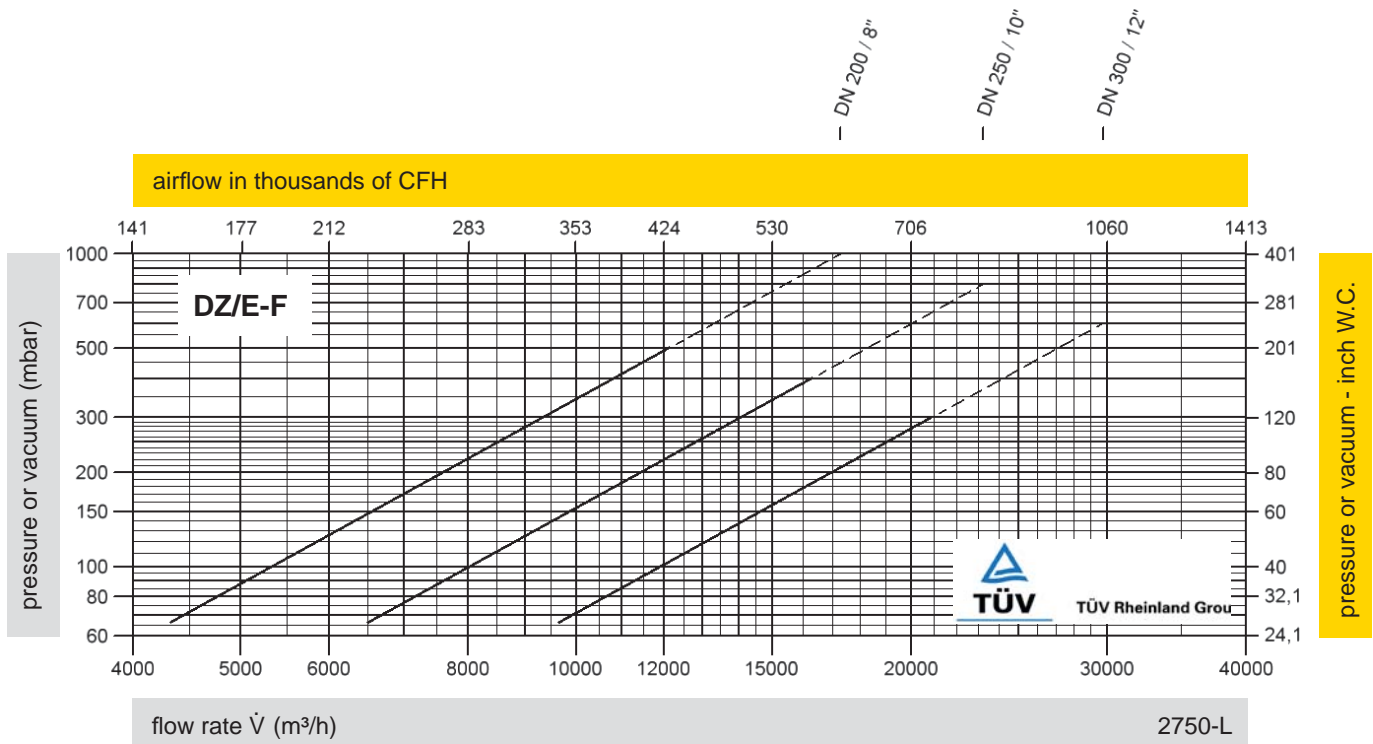
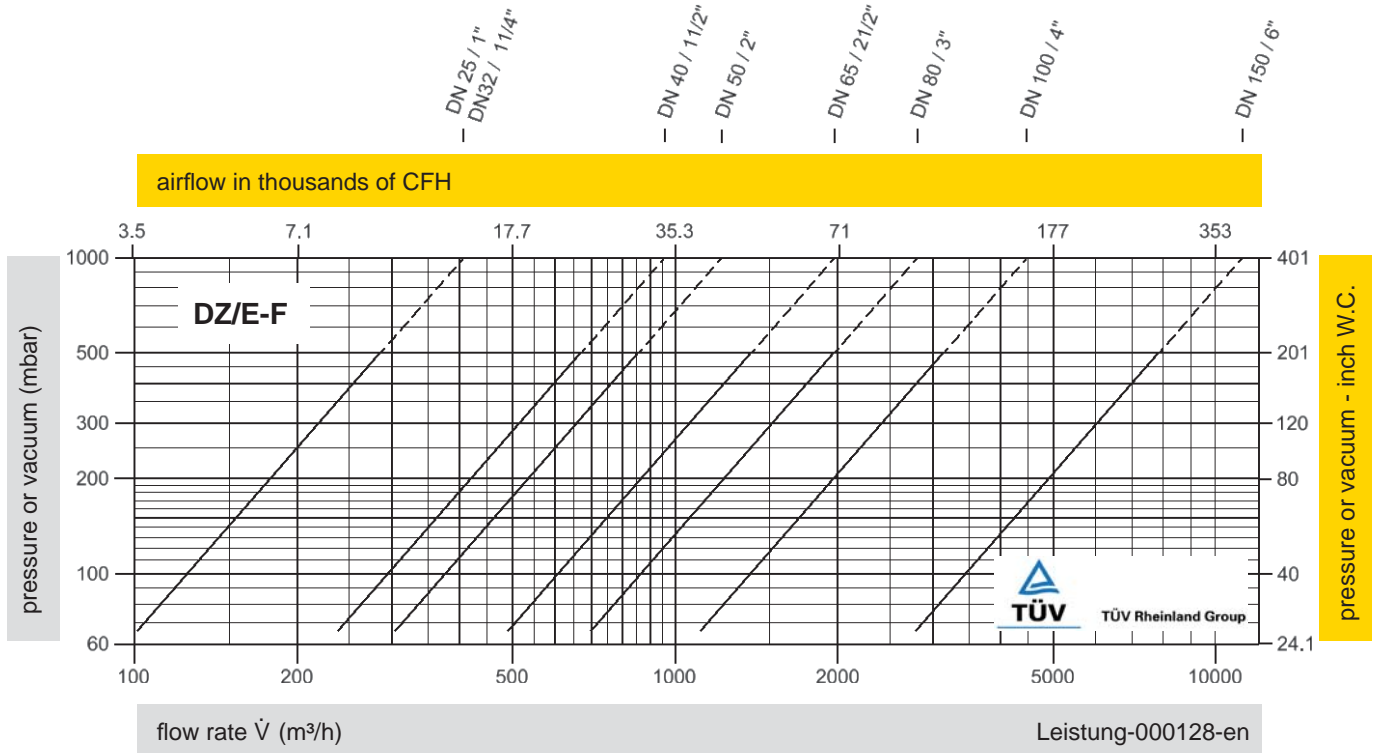

The flow capacity charts have been determined with a calibrated and TÜV certified flow capacity test rig. Volume flow \dot{V} in (m³/h) and CFH refer to the standard reference conditions of air ISO 6358 (20°C, 1bar). Conversion to other densities and temperatures refer to Vol. 1: "Technical Fundamentals".

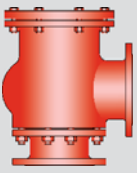

Pressure or Vacuum Relief Valve, In-Line

With ETFE Lining

PROTEGO® DZ/EA

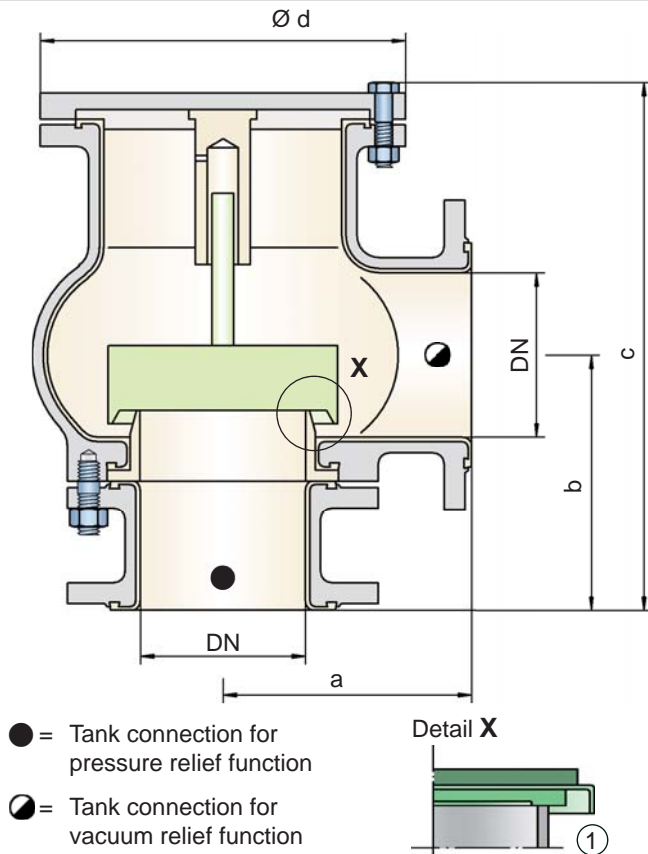

Flow direction marked at the housing by →

Pressure or vacuum settings:

±5.0 mbar up to ±50 mbar
±2.0 inch W.C. up to ±20 inch W.C.

For higher set pressure or vacuum refer to type DZ/EA-F

Function and Description

The lined PROTEGO® in-line valve DZ/EA is a state-of-the-art pressure or vacuum relief valve in right angle design. The lining makes this model a perfect solution for corrosive, polymerizing or sticky media. All internal parts are manufactured from PTFE or other highly corrosion resistant materials. Typically the valve is installed in the in- or out-breathing lines of tanks, vessels and process apparatus to protect against unallowable high or low pressure. The valve prevents emission losses almost up to the set pressure or provides protection from product entry into the system.

The device will start to open as soon as the set pressure is reached and only requires 10% overpressure to full lift. Continuous investments into research and development have allowed PROTEGO® to develop a low pressure valve which has the same opening characteristic as a high pressure safety relief valve. This “full lift type” technology allows the valve to be set just 10% below the maximum allowable working pressure or vacuum (MAWP or MAWV) of the tank and still safely vent the required mass flow. The opening characteristic is the same for pressure

and vacuum relief. Due to our highly developed manufacturing technology the tank pressure is maintained up to set pressure with a tightness that is far superior to the conventional standard. This feature is facilitated by specially finished PTFE valve seats or by use of hastelloy valve seats and with individually lapped valve pallets (1). After the excess pressure is discharged or the vacuum is compensated, the valve reseats and provides a tight seal.

The optimized fluid dynamic design of the valve body and valve pallet is a result of many years of research work, which allow a stable operation of the valve pallet and optimized performance resulting in reduction of product losses.

Special Features and Advantages

- “full lift type” technology valve utilizes only 10% overpressure to reach full lift
- high performance seal reducing product loss below EPA’s 500ppm rule preventing environmental pollution
- based on 10% technology the set pressure is close to the opening pressure which results in best possible pressure management of the system compared to conventional 40%- or 100%- technology valves
- internal lining and correct material selection makes this type the perfect solution for corrosive, polymerizing and sticky media
- optimized flow performance, which reduces capital cost to a minimum as smaller sized valves may be used
- can be used as pressure or vacuum relief valve
- compact right angle design saves space
- housing designed to 150 psi (PN 10)
- maintenance friendly design

Design and Specification

The valve pallet is weight loaded. **Higher set pressures for pressure and vacuum are achieved by using spring loaded type DZ/EA-F.**

In-line pressure or vacuum relief valve,
standard design

DZ/EA

Additional special devices available upon request

Within piping systems the influence of backpressure has to be considered in deciding the set pressure and opening characteristics. For special design solutions (e.g. partial load operation) the valve can be supplied with standard valve pallets (with proportional opening function).



Vents - 10% Technology
(Flyer pdf)



Leak Rate/10% Technology
(Flyer pdf)



Coated Devices
(Flyer pdf)



The optimised valve pallet
(Flyer pdf)

Table 1: Dimensions

Dimensions in mm / inches

To select the nominal size (DN), please use the flow capacity chart on the following page

DN	50 / 2"	80 / 3"	100 / 4"	150 / 6"
a	168 / 6.61	180 / 7.09	200 / 7.87	228 / 8.98
b	167 / 6.57	177 / 6.97	200 / 7.87	232 / 9.13
c	330 / 12.99	390 / 15.35	445 / 17.52	485 / 19.09
d	200 / 7.87	240 / 9.45	280 / 11.02	335 / 13.19

Table 2: Material selection for housing

Design	C	D	
Housing	Steel	Steel	Semi-conductive material and special material (e.g. PFA) upon request Special materials upon request
Lining	ETFE	ETFE	
Cover	Steel	Steel	
Valve seat	PTFE	Hastelloy	
Valve pallet	A	A, B	

Table 3: Material selection for valve pallet

Design	A	B	
Pressure range (mbar) (inch W.C.)	±5 up to ±50 ±2 up to ±20	±5 up to ±50 ±2 up to ±20	Special materials upon request For higher set pressure or vacuum refer to type DZ/EA-F
Valve pallet	PTFE	Hastelloy	
Sealing	PTFE	Metal to Metal	

Table 4: Flange connection type

EN 1092-1; Form B1	other types upon request
ASME B16.5; 150 lbs RFSF	

Flow Capacity Chart

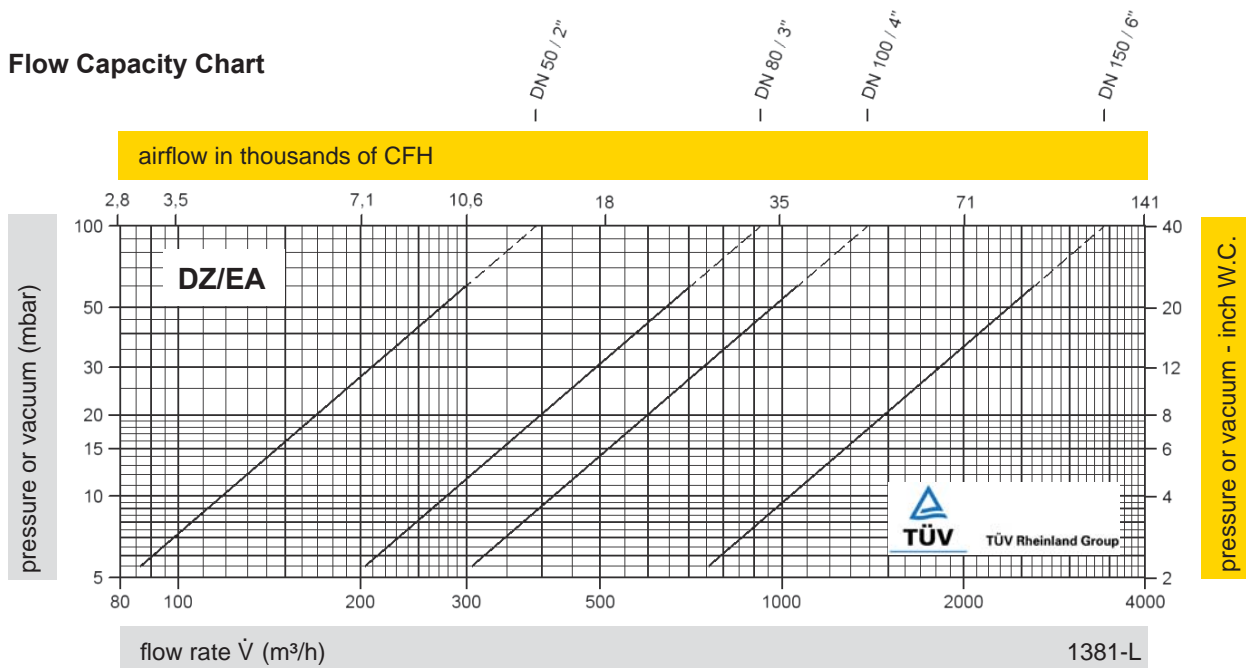

The flow capacity chart has been determined with a calibrated and TÜV certified flow capacity test rig. Volume flow \dot{V} in (m³/h) and CFH refer to the standard reference conditions of air ISO 6358 (20°C, 1bar). Conversion to other densities and temperatures refer to Vol. 1: "Technical Fundamentals".



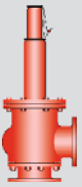

Pressure or Vacuum Relief Valve, In-Line

With ETFE Lining

PROTEGO® DZ/EA-F

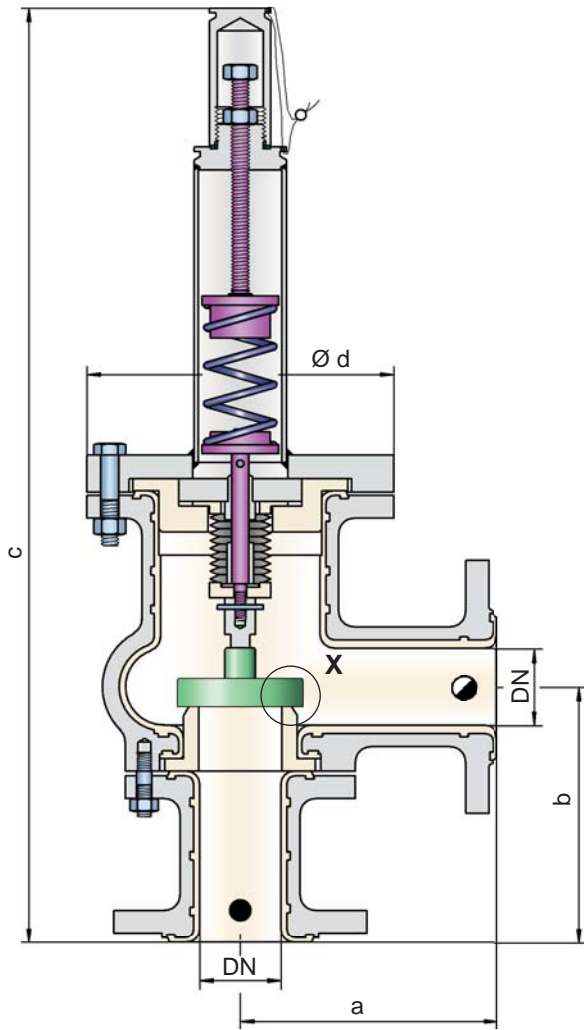

- = Tank connection for pressure relief function
- ◐ = Tank connection for vacuum relief function

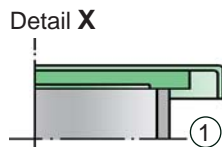

Flow direction marked at the housing by →

Pressure or vacuum settings:

±60 mbar up to ±500 mbar
 ±24 inch W.C. up to ±200 inch W.C.

For lower set pressure or vacuum refer to type DZ/EA

Function and Description

The lined PROTEGO® in-line valve DZ/EA-F is a state-of-the-art pressure or vacuum relief valve in right angle design for higher set pressures. The lining makes this model a perfect solution for corrosive, polymerizing or sticky media. All internal parts are manufactured from PTFE or other highly corrosion resistant materials. Typically the valve is installed in the in- or out-breathing lines of tanks, vessels and process apparatus to protect against unallowable high or low pressure. The valve prevents emission

losses almost up to the set pressure or provides protection from product entry into the system. This spring loaded model allows higher set pressures than the DZ/EA.

The device will start to open as soon as the set pressure is reached and only requires 10% overpressure to full lift. Continuous investments into research and development have allowed PROTEGO® to develop a low pressure valve which has the same opening characteristic as a high pressure safety relief valve. This “full lift type” technology allows the valve to be set just 10% below the maximum allowable working pressure or vacuum (MAWP or MAWV) of the tank and still safely vent the required mass flow. Due to our highly developed manufacturing technology the tank pressure is maintained up to set pressure with a tightness that is far superior to the conventional standard. This feature is facilitated by use of hastelloy valve seats and with individually lapped valve pallets (1). After the excess pressure is discharged or the vacuum is compensated, the valve reseats and provides a tight seal.

The optimized fluid dynamic design of the valve body and valve pallet is a result of many years of research work, which allow a stable operation of the valve pallet and optimized performance resulting in reduction of product losses.

Special Features and Advantages

- “full lift type” technology valve utilizes only 10% overpressure to reach full lift
- high performance seal reducing product loss below EPA’s 500ppm rule preventing environmental pollution
- based on 10% technology the set pressure is close to the opening pressure which results in best possible pressure management of the system compared to conventional 40%- or 100%- technology valves
- internal lining and correct material selection makes this type the perfect solution for corrosive, polymerizing and sticky media
- optimized flow performance, which reduces capital cost to a minimum as smaller sized valves may be used
- can be used as pressure or vacuum relief valve
- compact right angle design saves space
- housing designed to 150 psi (PN 10)
- spring loaded design for higher set pressures
- maintenance friendly design



Vents - 10% Technology
(Flyer pdf)



Leak Rate/10% Technology
(Flyer pdf)



Coated Devices
(Flyer pdf)



The optimised valve pallet
(Flyer pdf)

Designs and Specifications

The vent pallet is spring loaded. Lower set pressures for pressure and vacuum are achieved by using the type DZ/EA.

In-line pressure or vacuum relief valve, **DZ/EA-F**
standard design

Additional special devices available upon request.

Within piping systems the influence of backpressure has to be considered in deciding the set pressure and opening characteristics. For special design solutions (e.g. partial load operation) the valve can be supplied with standard valve pallets (with proportional opening function).

Table 1: Dimensions

Dimensions in mm / inches

To select the nominal size (DN), please use the flow capacity chart on the following page

DN	50 / 2"	80 / 3"	100 / 4"	150 / 6"
a	168 / 6.61	180 / 7.09	200 / 7.87	228 / 8.98
b	167 / 6.57	177 / 6.97	200 / 7.87	232 / 9.13
c	615 / 24.21	785 / 30.91	915 / 36.02	1160 / 45.67
d	200 / 7.87	240 / 9.45	280 / 11.02	335 / 13.19

Table 2: Material for housing

Design	B
Housing	Steel
Lining	ETFE
Cover	Steel
Valve seat	Hastelloy
Guiding disc	PTFE
Valve pallet	A

Semi-conductive material and special material (e.g. PFA) upon request

Table 3: Material for valve pallet

Design	A
Pressure range (mbar) (inch W.C.)	±60 up to ±500 ±24 up to ±200
Valve pallet	Hastelloy
Spindle / Guiding	Hastelloy
Sealing	Metal to Metal

Special materials upon request

Devices with higher set pressure or vacuum are available upon request, for lower set pressures or vacuum refer to type DZ/EA

Table 4: Flange connection type

EN 1092-1; Form B1
ASME B16.5; 150 lbs RFSF

other types upon request



for safety and environment

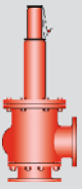

Pressure or Vacuum Relief Valve with ETFE Lining, In-Line

Flow Capacity Chart

PROTEGO® DZ/EA-F

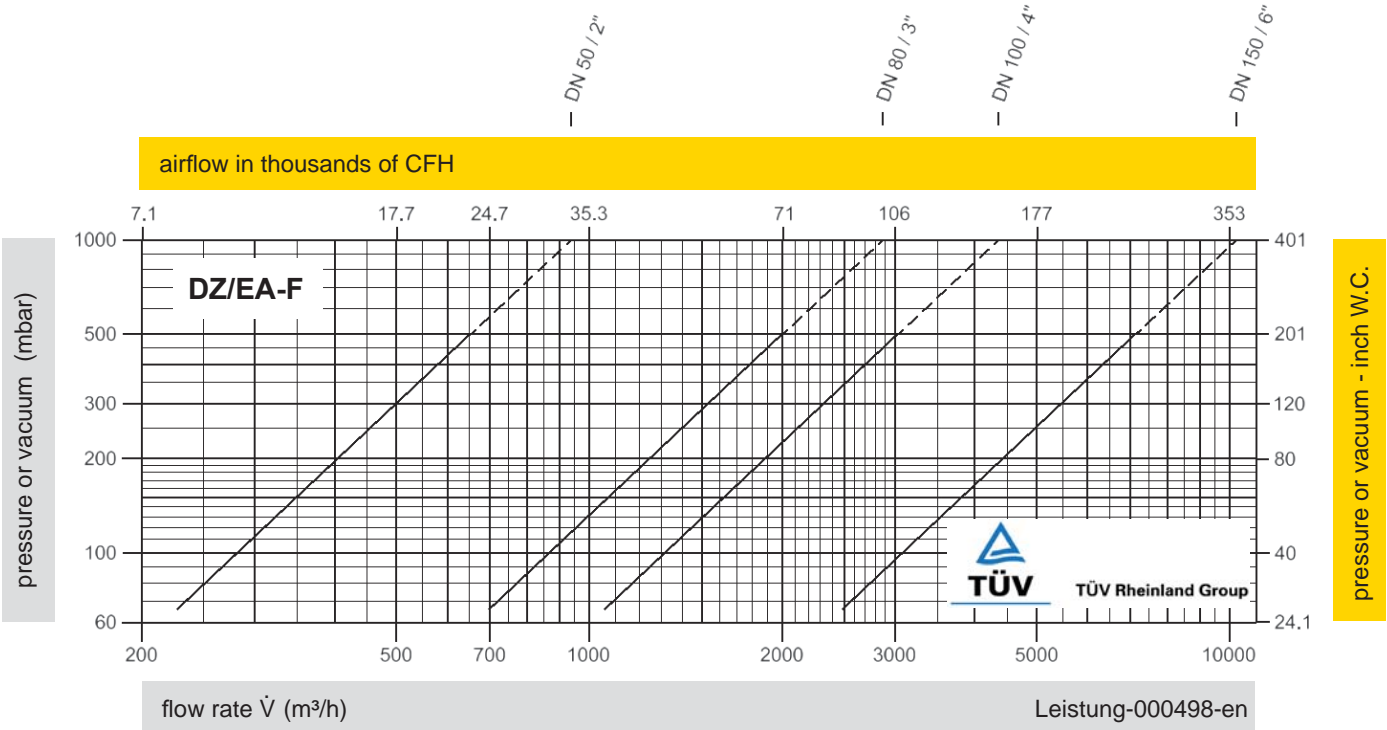

The flow capacity charts have been determined with a calibrated and TÜV certified flow capacity test rig. Volume flow \dot{V} in (m³/h) and CFH refer to the standard reference conditions of air ISO 6358 (20°C, 1bar). Conversion to other densities and temperatures refer to Vol. 1: "Technical Fundamentals".

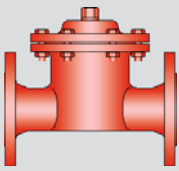

Pressure or Vacuum Relief Valve, In-Line



PROTEGO® DZ/T

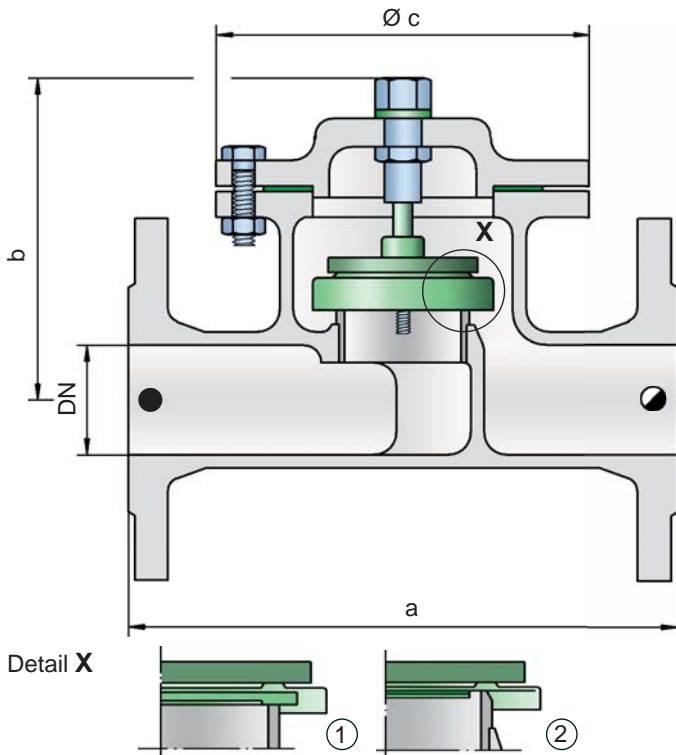

- = Tank connection for pressure relief function
- ◐ = Tank connection for vacuum relief function
- Flow direction marked at the housing by →

Pressure or vacuum settings:

DN 25 and 32	±3.5 mbar	up to ±60 mbar
DN 1" and 1 ¼"	±1.4 inch W.C.	up to ±24 inch W.C.
DN 40 up to 300	±2.0 mbar	up to ±60 mbar
DN 1 ½" up to 12"	±0.8 inch W.C.	up to ±24 inch W.C.

For higher set pressure or vacuum refer to type DZ/T-F

Function and Description

The PROTEGO® in-line valve DZ/T is a state-of-the-art pressure or vacuum relief valve. Typically the valve is installed in the in- or out-breathing lines of tanks, vessels and process apparatus to protect against unallowable high or low pressure. The valve prevents emission losses almost up to the set pressure or provides protection from product entry into the system.

The device will start to open as soon as the set pressure is reached and only requires 10% overpressure to full lift. Continuous investments into research and development have allowed PROTEGO® to develop a low pressure valve which has the same opening characteristic as a high pressure safety relief valve. This "full lift type" technology allows the valve to be set just 10% below the maximum allowable working pressure or vacuum (MAWP or MAWV) of the tank and still safely vent the required mass flow. Due to our highly developed manufacturing technology the tank pressure is maintained up to set pressure

with a tightness that is far superior to the conventional standard. This feature is facilitated by valve seats made of high quality stainless steel and with individually lapped valve pallets (1) or with an air cushion seal (2) in conjunction with high quality FEP diaphragm. The valve pallets are also available with a PTFE seal to prevent the valve pallets from sticking when sticky products are used and to enable the use of corrosive fluids. After the excess pressure is discharged or the vacuum is compensated, the valve reseats and provides a tight seal.

The optimized fluid dynamic design of the valve body and valve pallet is a result of many years of research work, which allow a stable operation of the valve pallet and optimized performance resulting in reduction of product losses.

Special Features and Advantages

- "full lift type" technology valve utilizes only 10% overpressure to reach full lift
- high performance seal reducing product loss below EPA's 500ppm rule preventing environmental pollution
- based on 10% technology the set pressure is close to the opening pressure which results in best possible pressure management of the system compared to conventional 40%- or 100%- technology valves
- optimized flow performance, which reduces capital cost to a minimum as smaller sized valves may be used
- can be used as pressure or vacuum relief valve
- can be installed in explosion hazardous areas
- housing designed to 150 psi (PN 10)
- maintenance friendly design

Designs and Specifications

The valve pallet is weight loaded. **Higher set pressures for pressure and vacuum are achieved by using spring loaded type DZ/T-F.**

Two different designs are available:

In-line pressure or vacuum relief valve, standard design

DZ/T -

In-line pressure or vacuum relief valve with heating jacket

DZ/T -

Additional special devices available upon request

Within piping systems the influence of backpressure has to be considered in deciding the set pressure and opening characteristics. For special design solutions (e.g. partial load operation) the valve can be supplied with standard valve pallets (with proportional opening function).



Vents - 10% Technology
(Flyer pdf)



Leak Rate/10% Technology
(Flyer pdf)



Coated Devices
(Flyer pdf)



The optimised valve pallet
(Flyer pdf)

Table 1: Dimensions

Dimensions in mm / inches

To select the nominal size (DN), please use the flow capacity chart on the following page

DN	25 / 1"	32 / 1 ¼"	40 / 1 ½"	50 / 2"	65 / 2 ½"	80 / 3"	100 / 4"	150 / 6"	200 / 8"	250 / 10"	300 / 12"
a	220/8.66	220/8.66	250/9.84	250/9.84	340/13.39	340/13.39	380/14.96	460/18.11	550/21.65	650/25.59	700/27.56
b	140/5.51	140/5.51	190/7.48	190/7.48	210/8.27	210/8.27	240/9.45	305/12.01	460/18.11	515/20.28	555/21.85
c	150/5.91	150/5.91	170/6.69	170/6.69	235/9.25	235/9.25	280/11.02	335/13.19	420/16.54	505/19.88	565/22.24

Dimensions for pressure or vacuum relief valve with heating jacket upon request

Table 2: Material selection for housing

Design	A	B	C
Housing	Steel	Stainless Steel	Hastelloy
Heating jacket (DZ/T-H...)	Steel	Stainless Steel	Stainless Steel
Valve seat	Stainless Steel	Stainless Steel	Hastelloy
Gasket	PTFE	PTFE	PTFE
Valve pallet DN 40 - 300 / 1 ½" - 12"	A, C, E, F	A, C, E, F	B, D, G
Valve pallet DN 25 - 32 / 1" - 1 ¼"	H, I, J	H, I, J	-

Option: Housing with ECTFE-lining
Special materials upon request

Table 3: Material selection for valve pallet

DN 40 - 300 / 1 ½" - 12"

Design	A	B	C	D	E	F	G
Pressure range (mbar) (inch W.C.)	±2.0 up to ±3.5 ±0.8 up to ±1.4	±2.0 up to ±3.5 ±0.8 up to ±1.4	±3.5 up to ±14 ±1.4 up to ±5.6	±3.5 up to ±14 ±1.4 up to ±5.6	±14 up to ±60 ±5.6 up to ±24	±14 up to ±60 ±5.6 up to ±24	±14 up to ±60 ±5.6 up to ±24
Valve pallet	Aluminium	Titanium	Stainless Steel	Titanium	Stainless Steel	Stainless Steel	Hastelloy
Sealing	FEP	FEP	FEP	FEP	Metal to Metal	PTFE	Metal to Metal

DN 25 - 32 / 1" - 1 ¼"

Design	H	I	J
Pressure range (mbar) (inch W.C.)	±3,5 up to ±15 ±1.4 up to ±6.0	±15 up to ±60 ±6.0 up to ±24	±15 up to ±60 ±6.0 up to ±24
Valve pallet	PTFE	Stainless Steel	Stainless Steel
Sealing	PTFE	Metal to Metal	PTFE

Special materials upon request

For higher set pressure or vacuum refer to type DZ/T-F

Table 3: Flange connection type

EN 1092-1; Form B1	other types upon request
ASME B16.5; 150 lbs RFSF	



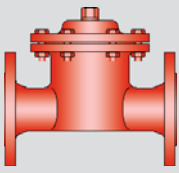

Pressure or Vacuum Relief Valve, In-Line

Flow Capacity Chart

PROTEGO® DZ/T

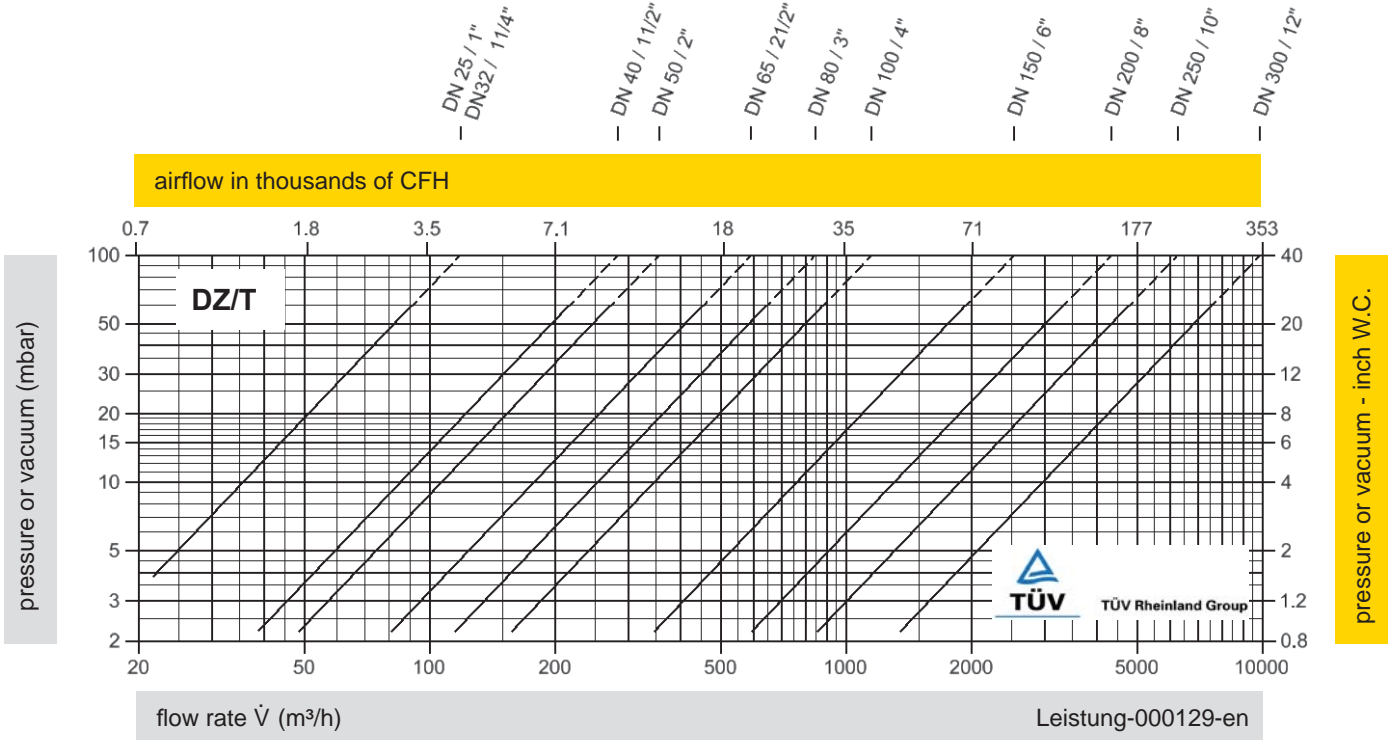

The flow capacity charts have been determined with a calibrated and TÜV certified flow capacity test rig. Volume flow \dot{V} in (m³/h) and CFH refer to the standard reference conditions of air ISO 6358 (20°C, 1bar). Conversion to other densities and temperatures refer to Vol. 1: "Technical Fundamentals".

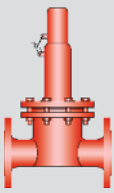

Pressure or Vacuum Relief Valve, In-Line



PROTEGO® DZ/T-F

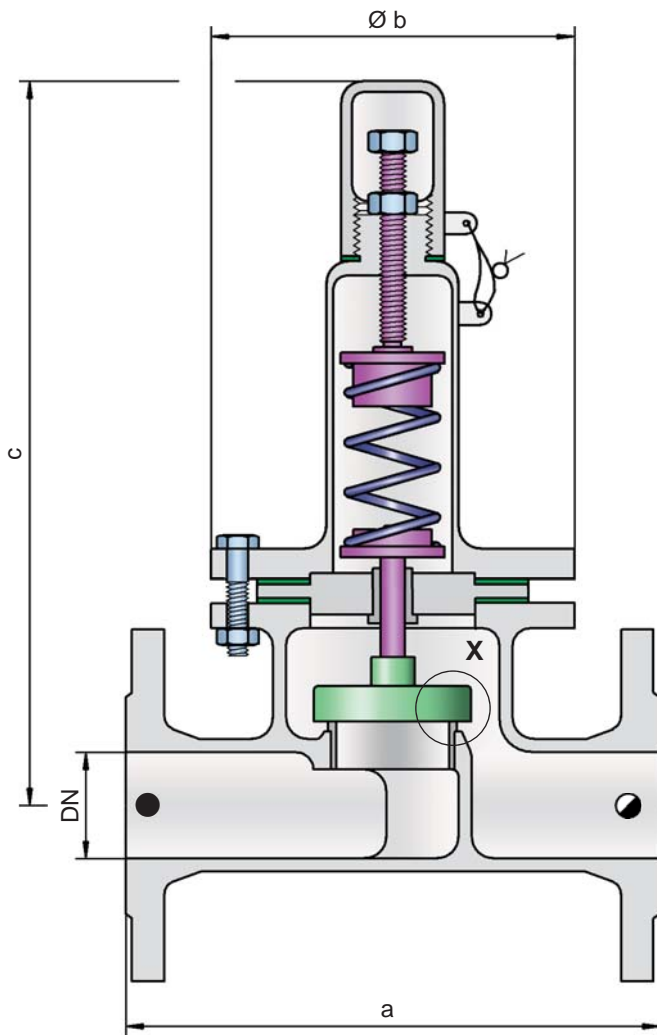

- = Tank connection for pressure relief function
- = Tank connection for vacuum relief function

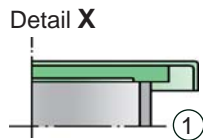

Flow direction marked at the housing by →

Pressure or vacuum settings:

±60 mbar	up to ±500 mbar (DN 25/1" up to 200/8")
±24 inch W.C.	up to ±200 inch W.C.
±60 mbar	up to ±400 mbar (DN 250/10")
±24 inch W.C.	up to ±160 inch W.C.
±60 mbar	up to ±300 mbar (DN 300/12")
±24 inch W.C.	up to ±120 inch W.C.

Devices with higher set pressure or vacuum are available upon request, for lower set pressures or vacuum refer to type DZ/T.

Function and Description

The PROTEGO® in-line valve DZ/T-F is a state-of-the-art pressure or vacuum relief valve for higher system pressures. Typically the valve is installed in the in- or out-breathing lines of Tanks,

Vessels and process apparatus to protect against unallowable high or low pressure. The valve prevents emission losses almost up to the set pressure or provides protection from product entry into the system. As this device is equipped with a spring higher set pressures can be reached compared to the DZ/T.

The device will start to open as soon as the set pressure is reached and only requires 10% overpressure to full lift. Continuous investments into research and development have allowed PROTEGO® to develop a low pressure valve which has the same opening characteristic as a high pressure safety relief valve. This "full lift type" technology allows the valve to be set just 10% below the maximum allowable working pressure or vacuum (MAWP or MAWV) of the tank and still safely vent the required mass flow. The opening characteristic is the same for pressure and vacuum relief. Due to our highly developed manufacturing technology the tank pressure is maintained up to set pressure with a tightness that is far superior to the conventional standard. This feature is facilitated by valve seats made of high quality stainless steel and with individually lapped valve pallets (1) and rugged valve bodies. After the excess pressure is discharged or the vacuum is compensated, the valve reseats and provides a tight seal.

The optimized fluid dynamic design of the valve body and valve pallet is a result of many years of research work, which allow a stable operation of the valve pallet and optimized performance resulting in reduction of product losses.

Special Features and Advantages

- "full lift type" technology valve utilizes only 10% overpressure to reach full lift
- high performance seal reducing product loss below EPA's 500ppm rule preventing environmental pollution
- based on 10% technology the set pressure is close to the opening pressure which results in best possible pressure management of the system compared to conventional 40%- or 100%- technology valves
- optimized flow performance, which reduces capital cost to a minimum as smaller sized valves may be used
- can be used as pressure or vacuum relief valve
- can be installed in explosion hazardous areas
- housing designed to 150 psi (PN 10)
- spring loaded for elevated set pressures
- maintenance friendly design



Vents - 10% Technology
(Flyer pdf)



Leak Rate/10% Technology
(Flyer pdf)



Coated Devices
(Flyer pdf)



The optimised valve pallet
(Flyer pdf)

Designs and Specifications

The valve pallet is spring loaded. Lower set pressures for pressure and vacuum are achieved by using the weight loaded type DZ/T.

Two different designs are available:

In-line pressure or vacuum relief valve, standard design **DZ/T-F** -

In-line pressure or vacuum relief valve with heating jacket **DZ/T-F** -

Additional special devices available upon request

Within piping systems the influence of backpressure has to be considered in deciding the set pressure and opening characteristics. For special design solutions (e.g. partial load operation) the valve can be supplied with standard valve pallets (with proportional opening function).



Spring-loaded PV-Valves
Maintenance-friendly design (Flyer pdf)

Table 1: Dimensions

Dimensions in mm / inches

To select the nominal size (DN), please use the flow capacity charts on the following pages

DN	25 / 1"	32 / 1 ¼"	40 / 1 ½"	50 / 2"	80 / 3"	100 / 4"	125 / 5"	150 / 6"
a	220 / 8.66	220 / 8.66	250 / 9.84	250 / 9.84	340 / 13.39	380 / 14.96	460 / 18.11	460 / 18.11
b	150 / 5.91	150 / 5.91	170 / 6.69	170 / 6.69	235 / 9.25	280 / 11.02	335 / 13.19	335 / 13.19
c	395 / 15.55	395 / 15.55	420 / 16.54	420 / 16.54	570 / 22.44	680 / 26.77	940 / 37.01	940 / 37.01
DN	200 / 8"	250 / 10"	300 / 12"					
a	550 / 21.65	650 / 25.59	700 / 27.56					
b	420 / 16.54	505 / 19.88	565 / 22.24					
c	1160 / 45.67	1215 / 47.83	1255 / 49.41					

Dimensions for pressure or vacuum relief valve with heating jacket upon request

Table 2: Material selection for housing

Design	A	B	
Housing	Steel	Stainless Steel	Option: Housing with ECTFE-lining
Heating jacket (DZ/T-F-H-...)	Steel	Stainless Steel	
Valve seat	Stainless Steel	Stainless Steel	Special materials upon request
Gasket	PTFE	PTFE	
Valve pallet	A	A	

Table 3: Material of valve pallet

Design	A	
Pressure range (mbar) (inch W.C.)	±60 up to ±500 ±24 up to ±200	Special materials upon request
Valve pallet	Stainless Steel	Devices with higher set pressure or vacuum are available upon request, for lower set pressures or vacuum refer to type DZ/T.
Sealing	Metal to Metal	
Pressure spring	Stainless Steel	

Table 4: Flange connection type

EN 1092-1; Form B1	other types upon request
ASME B16.5; 150 lbs RFSF	



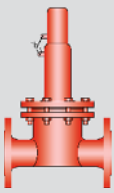

Pressure or Vacuum Relief Valve, In-Line

Flow Capacity Charts

PROTEGO® DZ/T-F

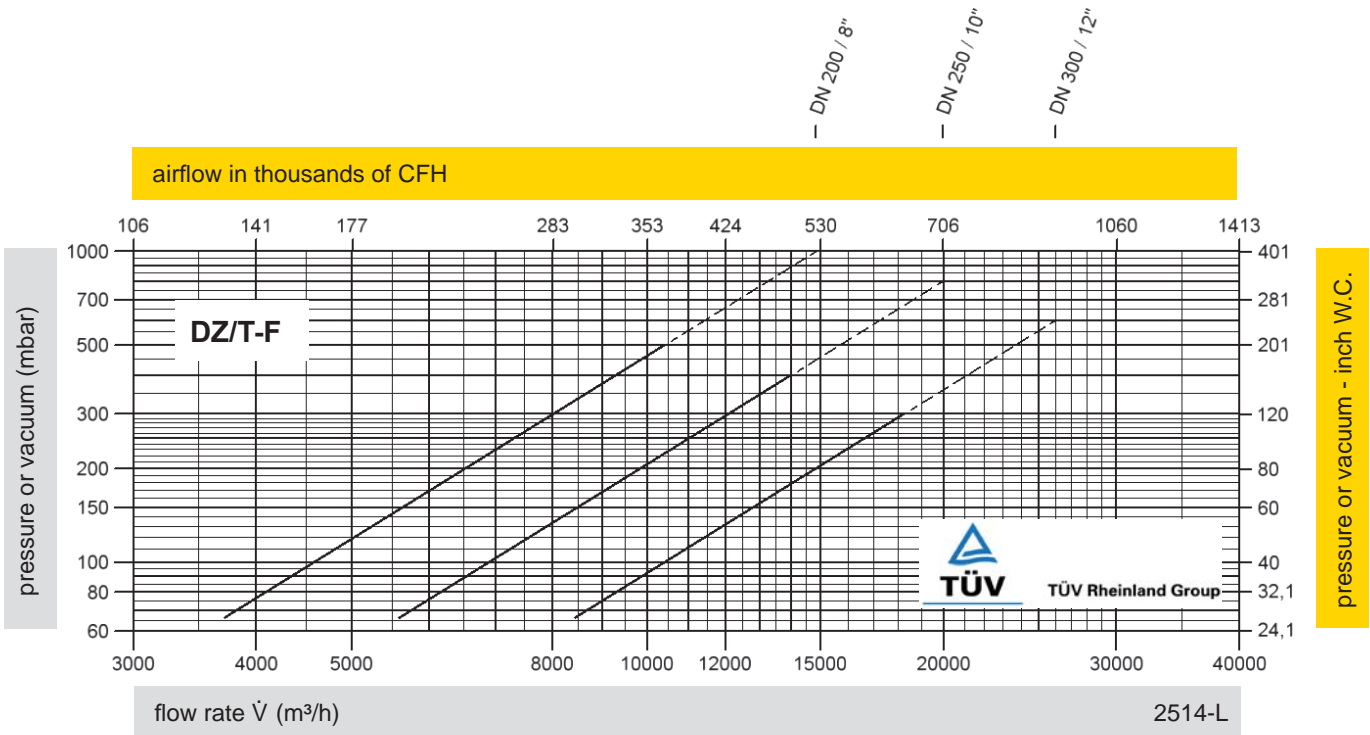
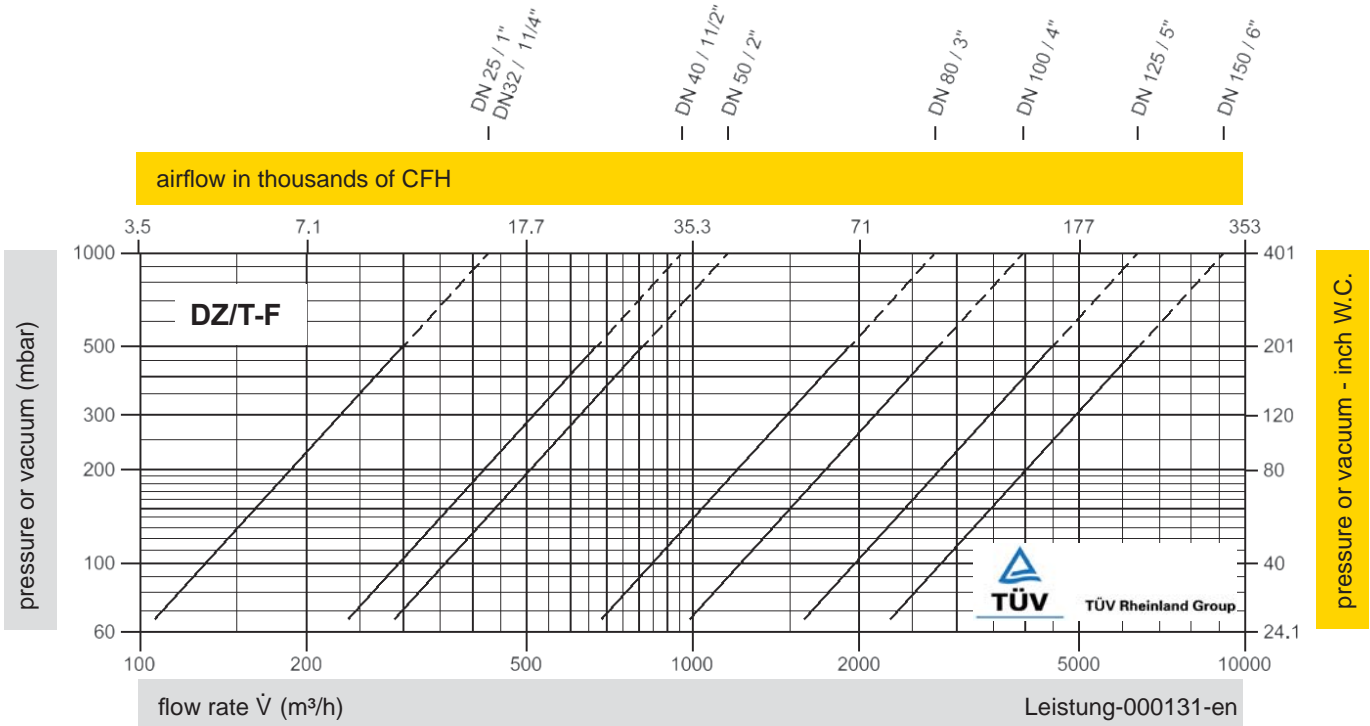

The flow capacity charts have been determined with a calibrated and TÜV certified flow capacity test rig. Volume flow \dot{V} in (m³/h) and CFH refer to the standard reference conditions of air ISO 6358 (20°C, 1bar). Conversion to other densities and temperatures refer to Vol. 1: "Technical Fundamentals".

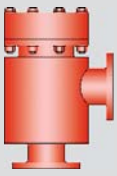

Pressure or Vacuum Relief Valve, In-Line



PROTEGO® R/KSM

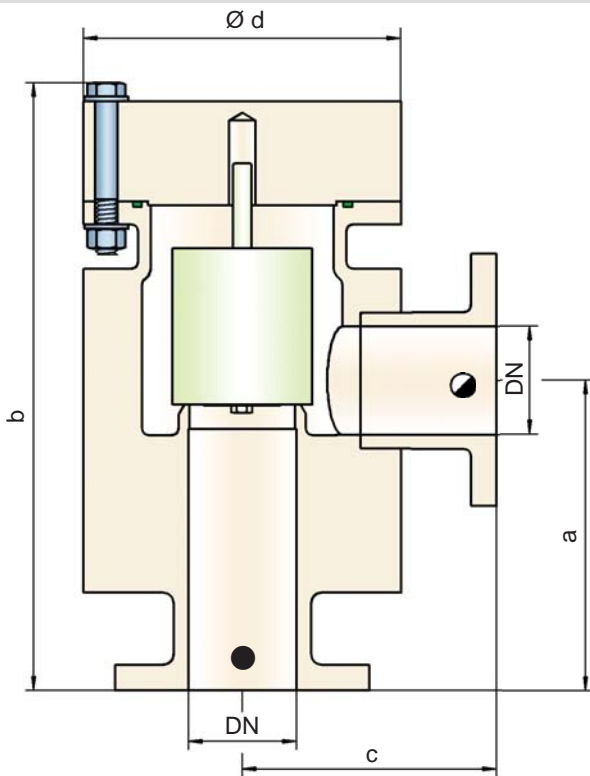

● = Tank connection for pressure relief function

○ = Tank connection for vacuum relief function

Flow direction marked at the housing by →

Pressure or vacuum settings:

±6.0 mbar up to ±100 mbar (DN 50/2")

±2.4 inch W.C. up to ±40 inch W.C.

±4.0 mbar up to ±100 mbar (DN 80/3")

±1.6 inch W.C. up to ±40 inch W.C.

±4.5 mbar up to ±100 mbar (DN 100/4" - DN 200/8")

±1.8 inch W.C. up to ±40 inch W.C.

Function and Description

The PROTEGO® in-line valve R/KSM is a state-of-the-art pressure or vacuum relief valve in right angle design made out of highgrade synthetic material. Typically the valve is installed in the in- or out-breathing lines of tanks, vessels and process apparatus to protect against unallowable high or low pressure. The valve prevents emission losses almost up to the set pressure or provides protection from product entry into the system. The valve is a perfect solution for corrosive, polymerizing or sticky media.

The device will start to open as soon as the set pressure is reached and only requires 10% overpressure to full lift. Continuous investments into research and development have allowed PROTEGO® to develop a low pressure valve which has the same opening characteristic as a high pressure safety relief valve. This "full lift type" technology allows the valve to be set just 10% below the maximum allowable working pressure or vacuum (MAWP or MAWV) of the tank and still safely vent the required mass flow. The opening characteristic for pressure and vacuum side is the same.

Due to our highly developed manufacturing technology, the tank pressure is maintained up to the set pressure, with a tightness that is far superior to the conventional standard. This feature is facilitated by special valve seats made of high quality synthetic material or PTFE. After the excess pressure is discharged or vacuum is compensated, the valve reseats and provides a tight seal.

The optimized fluid dynamic design of the valve body and valve pallet is a result of many years of research work, which allow a stable operation of the valve pallet and optimized performance resulting in reduction of product losses.

Special Features and Advantages

- "full lift type" technology valve utilizes only 10% overpressure to reach full lift
- extreme tightness and hence least possible product losses and reduced environmental pollution
- based on 10% technology the set pressure is close to the opening pressure which results in best possible pressure management of the system compared to conventional 40%- or 100%- technology valves
- can be used as pressure or vacuum relief valve
- compact right angle design saves space
- optimized flow performance, which reduces capital cost to a minimum as smaller sized valves may be used
- corrosion resistant valve
- weight reduction in comparison to steel/stainless steel
- smooth surface
- different plastics can be combined
- maintenance friendly design

Design and Specification

The valve pallet is weight loaded. Highest set pressure range can be reached with metal valve pallets.

In-line pressure or vacuum relief valve, **R/KSM** - standard design

Additional special devices available upon request

Within piping systems the influence of backpressure has to be considered in deciding the set pressure and opening characteristics.



Vents - 10% Technology
(Flyer pdf)



Leak Rate/10% Technology
(Flyer pdf)



Vents for corrosive vapor service
(Flyer pdf)

Table 1: Dimensions

Dimensions in mm / inches

To select the nominal size (DN), please use the flow capacity chart on the following page

DN	50 / 2"	80 / 3"	100 / 4"	150 / 6"	200 / 8"
a	200 / 7.87	245 / 9.65	300 / 11.81	370 / 14.57	625 / 24.61 (650 / 25.59)*
b	376 / 14.80	521 / 20.51	563 / 22.17 (523 / 20.59)*	687 / 27.05 (651 / 25.63)*	914 / 35.98 (912 / 35.91)*
c	150 / 5.91	200 / 7.87	225 / 8.86	280 / 11.02	350 / 13.78
d	180 / 7.09	250 / 9.84	300 / 11.81	350 / 13.78 (405 / 15.94)*	560 / 22.05 (500 / 19.68)*

* Dimensions in brackets only for PVDF

Table 2: Material selection for housing

Design	A	B	C	
Housing	PE	PP	PVDF	Special materials upon request
Valve seat	PE	PP	PVDF	
Gasket	FPM	FPM	FPM	
Valve pallet	A, C, D	B, C, D	C, D	

Table 3: Material selection for valve pallet

Design	A	B	C	D	
Pressure range (mbar) (inch W.C.)	±6.0 up to ±16 ±2.4 up to ±6.4	±5.5 up to ±16 ±2.2 up to ±6.4	±9.5 up to ±30 ±3.8 up to ±12	±30 up to ±100 ±12 up to ± 40	Special materials and devices with higher set pressure or vacuum are available upon request
Valve pallet	PE	PP	PVDF	Hastelloy	
Sealing	PTFE	PTFE	PTFE	PTFE	
Spindle guide	PE	PP	PVDF	Hastelloy	

Table 4: Flange connection type

EN 1092-1; Form A	other types upon request
ASME B16.5; 150 lbs FFSF	

Flow Capacity Chart

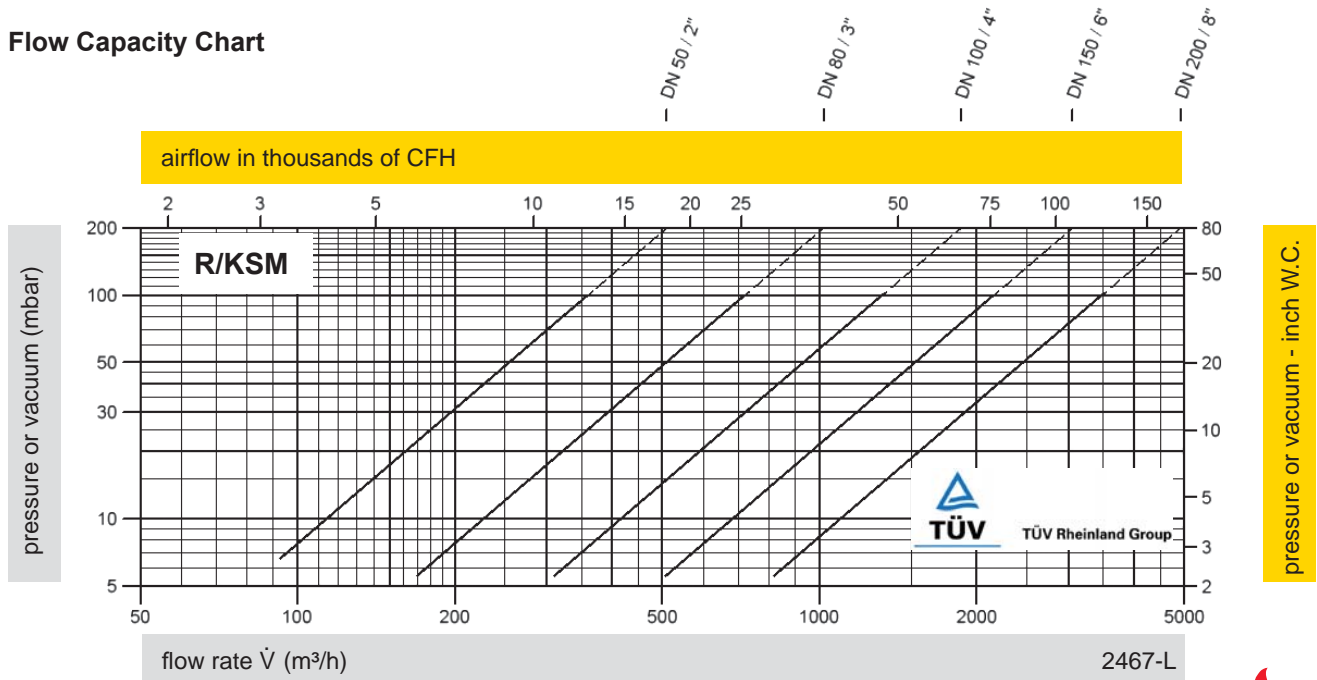

The flow capacity chart has been determined with a calibrated and TÜV certified flow capacity test rig.
Volume flow \dot{V} in (m^3/h) and CFH refer to the standard reference conditions of air ISO 6358 (20°C, 1bar).
Conversion to other densities and temperatures refer to Vol. 1: "Technical Fundamentals".



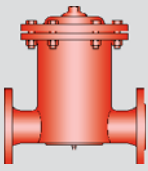

Pressure and Vacuum Relief Valve, In-Line



PROTEGO® DV/ZT

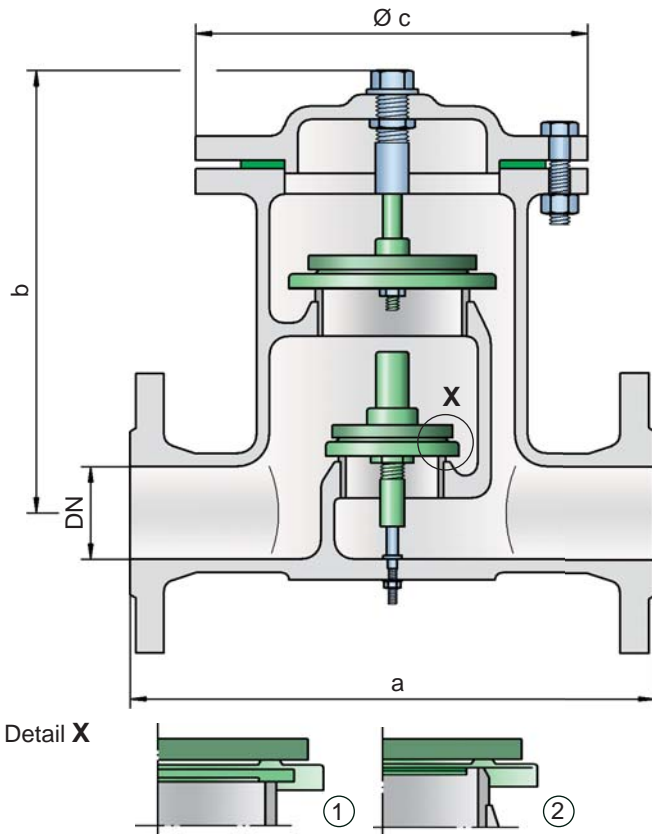

Tank connection depends upon flow capacity, set pressure and set vacuum for in- and outbreathing

Pressure or vacuum settings:

Upper valve pallet: ± 2.0 mbar up to ± 60 mbar
 ± 0.8 inch W.C. up to ± 24 inch W.C.

Lower valve pallet: ± 3.5 mbar up to ± 50 mbar
 ± 1.4 inch W.C. up to ± 20 inch W.C.

For higher set pressure refer to type DV/ZT-F. Lower set vacuum upon request.

Function and Description

The PROTEGO® in-line valve DV/ZT is a state-of-the-art pressure and vacuum relief valve. Typically the valve is installed in the in- and out-breathing lines of tanks, vessels and process apparatus to protect against unallowable high and low pressure. The valve prevents emission losses almost up to the set pressure and provides protection from product entry into the system. Due to its design the lower valve pallet is one size smaller than the upper valve pallet.

The device will start to open as soon as the set pressure is reached and only requires 10% overpressure to full lift. Continuous investments into research and development have allowed PROTEGO® to develop a low pressure valve which has the same opening characteristic as a high pressure safety relief valve. This "full lift type" technology allows the valve to be set just 10% below the maximum allowable working pressure or vacuum (MAWP or MAWV) of the tank and still safely vent the required mass flow. Due to our highly developed manufacturing

technology the tank pressure is maintained up to set pressure with a tightness that is far superior to the conventional standard. This feature is facilitated by valve seats made of high quality stainless steel and with individually lapped valve pallets (1) or with an air cushion seal (2) in conjunction with high quality FEP diaphragm. The valve pallets are also available with a PTFE seal to prevent the valve pallets from sticking when sticky products are used and to enable the use of corrosive fluids. After the excess pressure is discharged or vacuum is balanced, the valve reseats and provides a tight seal.

The optimized fluid dynamic design of the valve body and valve pallet is a result of many years of research work, which allow a stable operation of the valve pallet and optimized performance resulting in reduction of product losses.

Special Features and Advantages

- "full lift type" technology valve utilizes only 10% overpressure to reach full lift
- high performance seal reducing product loss below EPA's 500ppm rule preventing environmental pollution
- based on 10% technology the set pressure is close to the opening pressure which results in best possible pressure management of the system compared to conventional 40%- or 100%- technology valves
- optimized flow performance, which reduces capital cost to a minimum as smaller sized valves may be used
- can be installed in explosion hazardous areas
- housing designed to 150 psi (PN 10)
- maintenance friendly design

Designs and Specifications

The valve pallets are weight loaded. **Higher set pressures are achieved by using spring loaded type DV/ZT-F.**

Two different designs are available:

In-line pressure and vacuum relief valve, standard design **DV/ZT - □**

In-line pressure and vacuum relief valve with heating jacket **DV/ZT - □^H**

Additional special devices available upon request.

Within piping systems the influence of backpressure has to be considered in deciding the set pressure and opening characteristics. For special design solutions (e.g. partial load operation) the valve can be supplied with standard valve pallets (with proportional opening function).



Vents - 10% Technology
(Flyer pdf)



Leak Rate/10% Technology
(Flyer pdf)



Coated Devices
(Flyer pdf)



The optimised valve pallet
(Flyer pdf)

Table 1: Dimensions

Dimensions in mm / inches

To select the nominal size (DN), please use the flow capacity charts on the following page

DN	40 / 1 1/2"	50 / 2"	80 / 3"	100 / 4"	150 / 6"
a	280 / 11.02	280 / 11.02	340 / 13.39	390 / 15.35	520 / 20.47
b	270 / 10.63	270 / 10.63	290 / 11.42	355 / 13.98	425 / 16.73
c	210 / 8.27	210 / 8.27	280 / 11.02	310 / 12.20	390 / 15.35

Larger sizes upon request

Dimensions for pressure and vacuum relief valve with heating jacket upon request

Table 2: Material selection for housing

Design	A	B	
Housing	Steel	Stainless Steel	Option: Housing with ECTFE-lining
Heating jacket (DV/ZT-H-...)	Steel	Stainless Steel	
Valve seat	Stainless Steel	Stainless Steel	Special materials upon request
Gasket	PTFE	PTFE	

Table 3: Material selection for upper valve pallet

Design	A	B	C	D	
Pressure range (mbar) (inch W.C.)	±2.0 up to ±3.5 ±0.8 up to ±1.4	±3.5 up to ±14 ±1.4 up to ±5.6	±14 up to ±60 ±5.6 up to ±24	±14 up to ±60 ±5.6 up to ±24	Special materials upon request For higher set pressures refer to type DV/ZT-F
Valve pallet	Aluminium	Stainless Steel	Stainless Steel	Stainless Steel	
Sealing	FEP	FEP	Metal to Metal	PTFE	

Table 4: Material selection for lower valve pallet

Design	A	B	C	D	E	F
Pressure range (mbar) (inch W.C.)	±3.5 up to ±5.0 ±1.4 up to ±2.0	±5.0 up to ±14 ±2.0 up to ±5.6	±14 up to ±35 ±5.6 up to ±14	±35 up to ±50 ±14 up to ±20	±14 up to ±35 ±5.6 up to ±14	±35 up to ±50 ±14 up to ±20
Valve pallet	Aluminium	Stainless Steel	Stainless Steel	Stainless Steel	Stainless Steel	Stainless Steel
Sealing	FEP	FEP	Metal to Metal	Metal to Metal	PTFE	PTFE

Special materials and lower set vacuum upon request

Table 5: Flange connection type

EN 1092-1; Form B1	other types upon request
ASME B16.5; 150 lbs RFSF	



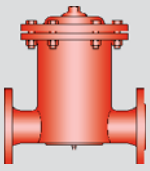

Pressure and Vacuum Relief Valve, In-Line

Flow Capacity Charts

PROTEGO® DV/ZT

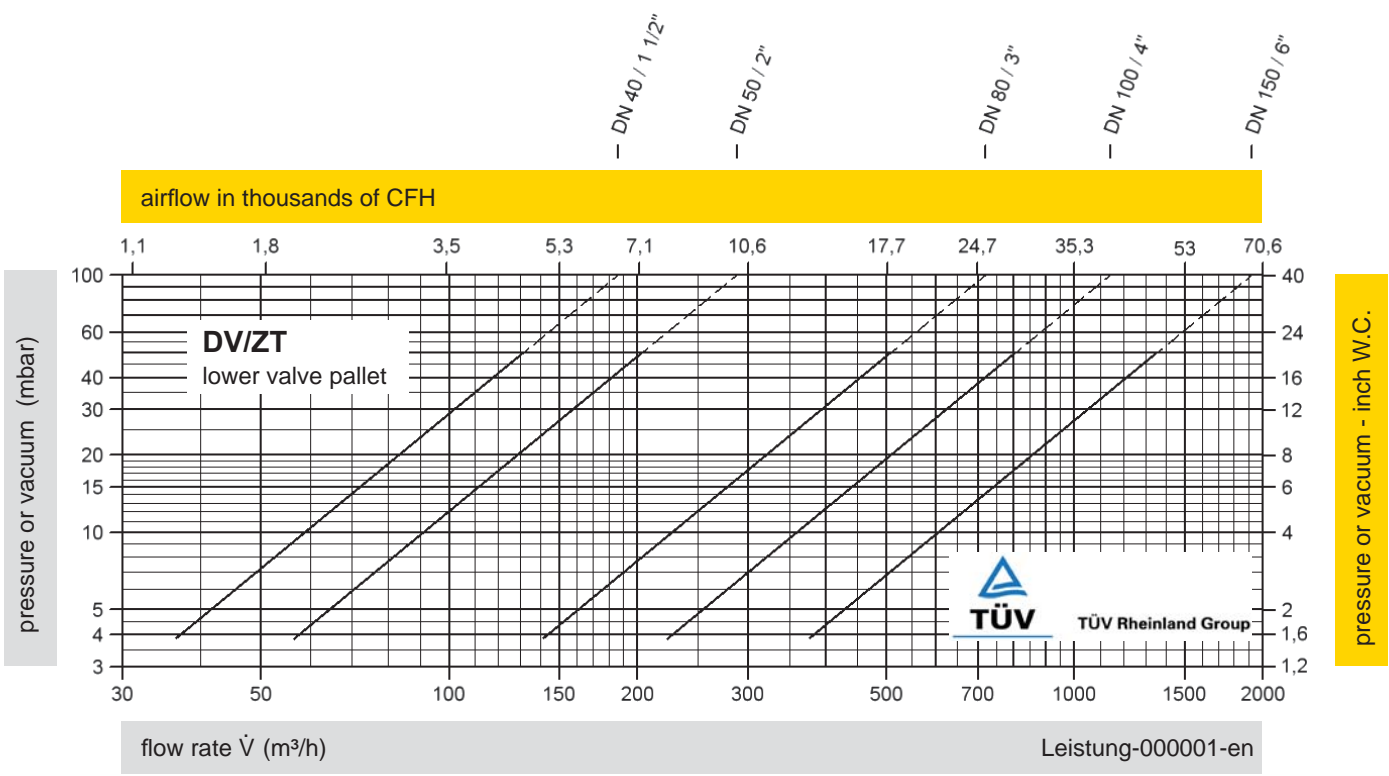
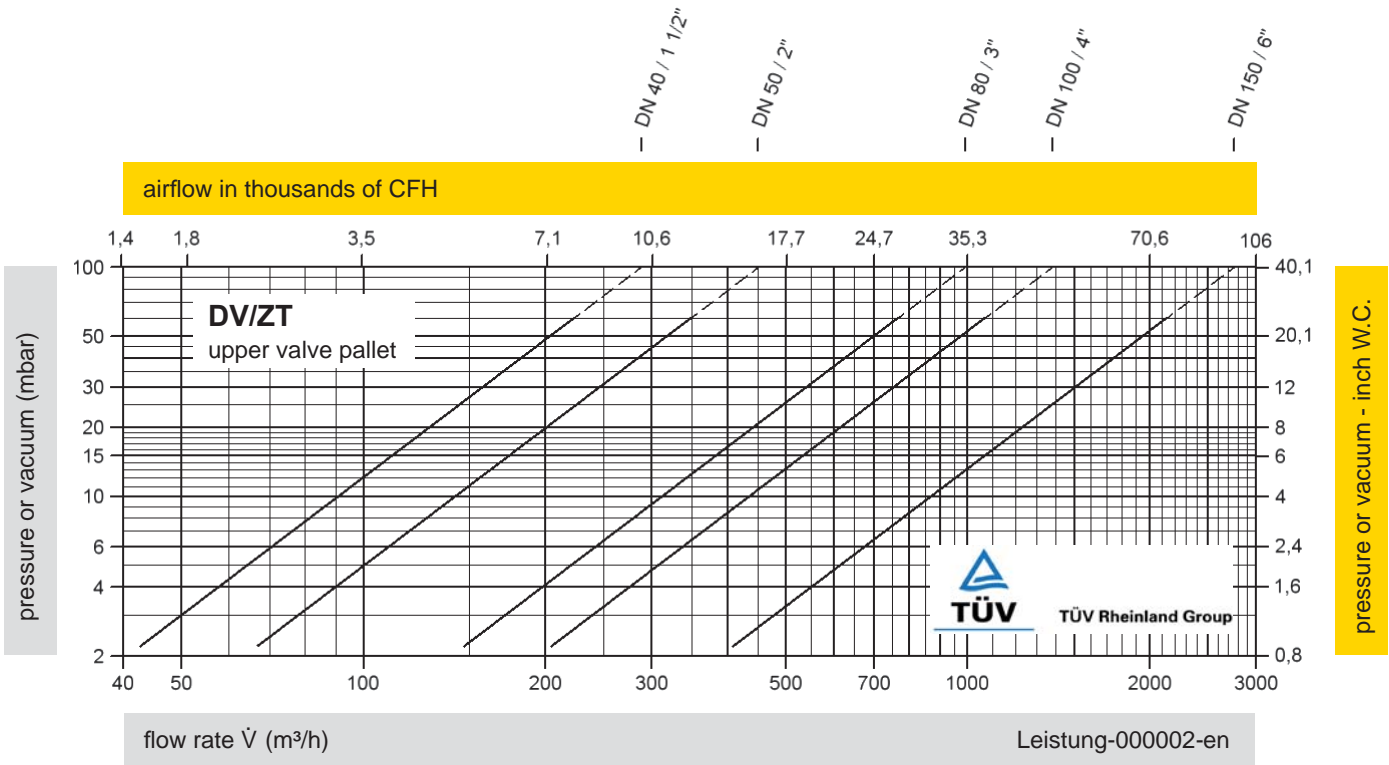

The flow capacity charts have been determined with a calibrated and TÜV certified flow capacity test rig. Volume flow \dot{V} in (m³/h) and CFH refer to the standard reference conditions of air ISO 6358 (20°C, 1bar). Conversion to other densities and temperatures refer to Vol. 1: "Technical Fundamentals".

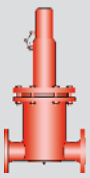

PROTEGO® DV/ZT-F

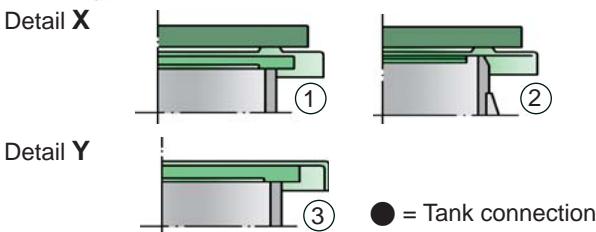
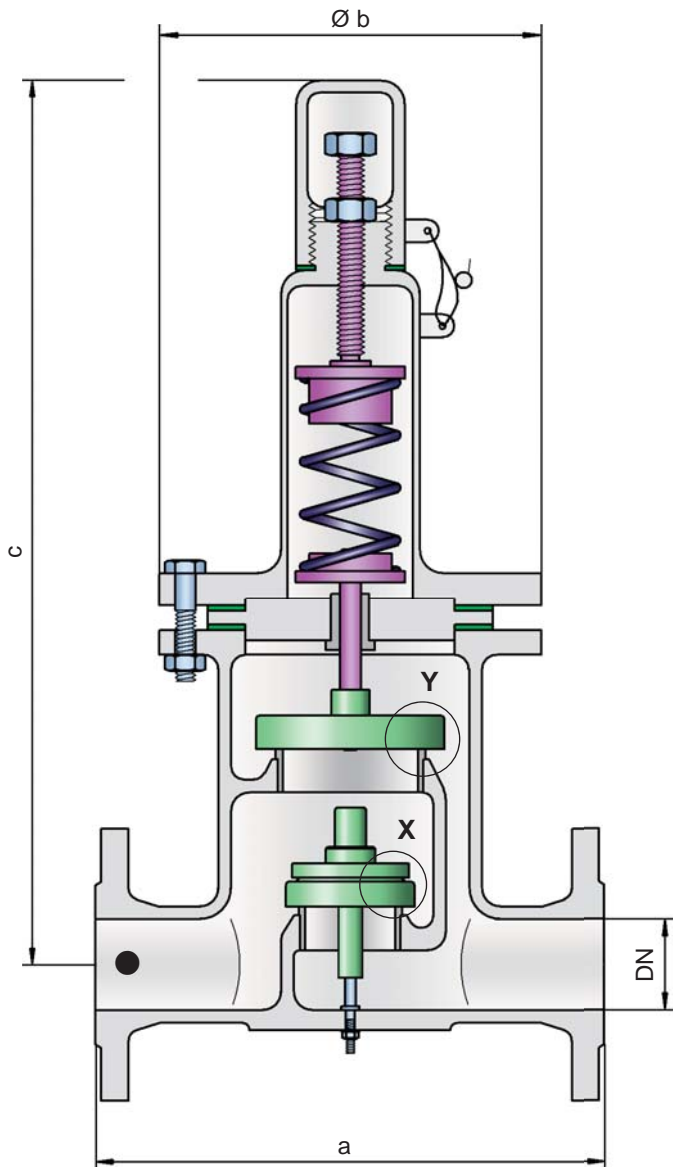

Settings:

Pressure:

+60 mbar up to +500 mbar (DN 40/1 1/2" up to 150/6")
 +24 inch W.C. up to +200 inch W.C.
 >+60 mbar up to +400 mbar (DN200/8";DN 250/10")
 >+24 inch W.C. up to +160 inch W.C.

Vacuum: -14 mbar up to -50 mbar
 -5.6 inch W.C. up to -20 inch W.C.

Vacuum: -3.5 mbar up to -14 mbar
 -1.4 inch W.C. up to -5.6 inch W.C.
 by set pressure up to +150 mbar / +60 inch W.C.

For lower set pressure refer to type DV/ZT.
 Higher set pressure and lower set vacuum upon request.

Function and Description

The PROTEGO® in-line valve DV/ZT-F is a state-of-the-art pressure and vacuum relief valve. Typically the valve is installed in the in- and out-breathing lines of tanks, vessels and process apparatus to protect against unallowable high and low pressure. The valve prevents emission losses almost up to the set pressure and provides protection from product entry into the system. Due to its design the vacuum valve pallet is one size smaller than the pressure valve pallet. Due to the spring loaded design higher set pressures can be achieved.

The device will start to open as soon as the set pressure is reached and only requires 10% overpressure to full lift. Continuous investments into research and development have allowed PROTEGO® to develop a low pressure valve which has the same opening characteristic as a high pressure safety relief valve. This "full lift type" technology allows the valve to be set just 10% below the maximum allowable working pressure or vacuum (MAWP or MAWV) of the tank and still safely vent the required mass flow. Due to our highly developed manufacturing technology the tank pressure is maintained up to set pressure with a tightness that is far superior to the conventional standard. This feature is facilitated by valve seats made of high quality stainless steel and with individually lapped valve pallets (1), (3) or with an air cushion seal (2) in conjunction with high quality FEP diaphragm and a rugged valve body. After the excess pressure is discharged or the vacuum is balanced, the valve reseats and provides a tight seal.

The optimized fluid dynamic design of the valve body and valve pallet is a result of many years of research work, which allow a stable operation of the valve pallet and optimized performance resulting in reduction of product losses.

Special Features and Advantages

- "full lift type" technology valve utilizes only 10% overpressure to reach full lift
- high performance seal reducing product loss below EPA's 500ppm rule preventing environmental pollution
- based on 10% technology the set pressure is close to the opening pressure which results in best possible pressure management of the system compared to conventional 40%- or 100%- technology valves
- optimized flow performance, which reduces capital cost to a minimum as smaller sized valves may be used
- can be installed in explosion hazardous areas
- housing designed to 150 psi (PN 10)
- spring loaded on pressure side to achieve higher set pressures
- maintenance friendly design



Vents - 10% Technology
(Flyer pdf)



Leak Rate/10% Technology
(Flyer pdf)



Coated Devices
(Flyer pdf)



The optimised valve pallet
(Flyer pdf)

Designs and Specifications

The pressure valve pallet is spring loaded, the vacuum valve pallet weight loaded. Lower set pressures for the pressure side are achieved through weight loaded type DV/ZT.

Two different designs are available:

In-line pressure and vacuum relief valve, standard design **DV/ZT-F**

In-line pressure and vacuum relief valve with heating jacket **DV/ZT-F - H**

Additional special devices available upon request

Within piping systems the influence of backpressure has to be considered in deciding the set pressure and opening characteristics. For special design solutions (e.g. partial load operation) the valve can be supplied with standard valve pallets (with proportional opening function).



Spring-loaded PV-Valves
Maintenance-friendly design (Flyer pdf)

Table 1: Dimensions

Dimensions in mm / inches

To select the nominal size (DN), please use the flow capacity charts on the following pages

DN	40 / 1 1/2"	50 / 2"	80 / 3"	100 / 4"	150 / 6"	200 / 8"	250 / 10"
a	280 / 11.02	280 / 11.02	340 / 13.39	390 / 15.35	520 / 20.47	650 / 25.59	750 / 29.53
b	210 / 8.27	210 / 8.27	280 / 11.02	310 / 12.20	390 / 15.35	565 / 22.24	610 / 24.02
c	605 / 23.82	605 / 23.82	730 / 28.74	870 / 34.25	1170 / 46.06	1030 / 40.55	1335 / 52.56

Larger sizes upon request

Dimensions for pressure and vacuum relief valve with heating jacket upon request

Table 2: Material selection for housing

Design	A	B	
Housing	Steel	Stainless Steel	Option: Housing with ECTFE-lining Special materials upon request
Heating jacket (DV/ZT-F-H-...)	Steel	Stainless Steel	
Valve seat	Stainless Steel	Stainless Steel	
Gasket	PTFE	PTFE	

Table 3: Material of pressure valve pallet

Design	A	
Pressure range (mbar) (inch W.C.)	>+60 up to +500 >+24 up to +200	Special materials upon request
Valve pallet	Stainless Steel	For lower set pressure use type DV/ZT. Higher set pressure and lower set vacuum upon request.
Sealing	Metal to Metal	
Pressure spring	Stainless Steel	

Table 4: Material selection for vacuum valve pallet

Design	A*	B*	C	D	
Pressure range (mbar) (inch W.C.)	-3.5 up to -5.0 -1.4 up to -2.0	<-5.0 up to -14 <-2.0 up to -5.6	<-14 up to -35 <-5.6 up to -14	<-35 up to -50 <-14 up to -20	Special materials and lower set vacuum upon request
Valve pallet	Aluminium	Stainless Steel	Stainless Steel	Stainless Steel	
Sealing	FEP	FEP	Metal to Metal	Metal to Metal	

* by set pressure up to +150 mbar / +60 inch W.C.

Table 5: Flange connection type

EN 1092-1; Form B1	other types upon request
ASME B16.5; 150 lbs RFSF	



for safety and environment

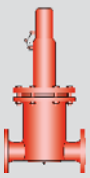

Pressure and Vacuum Relief Valve, In-Line

Flow Capacity Charts

PROTEGO® DV/ZT-F

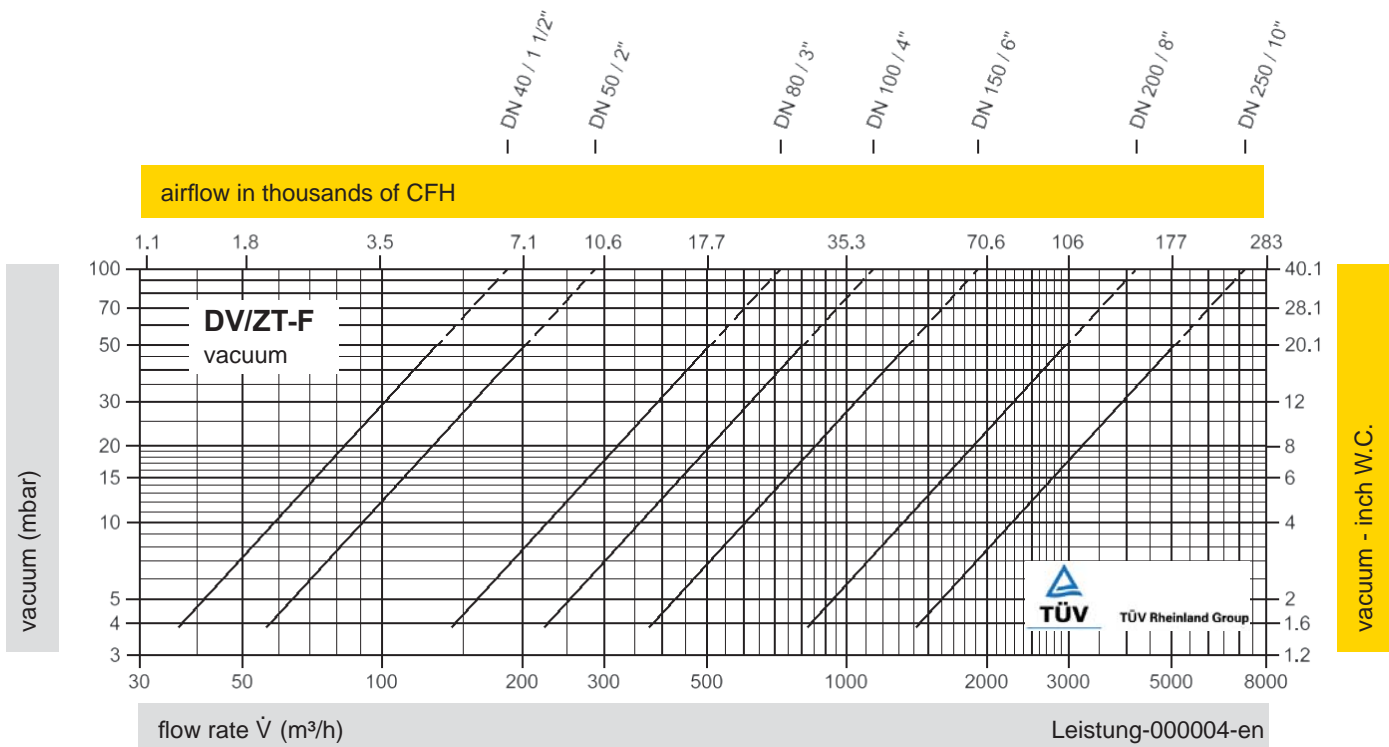
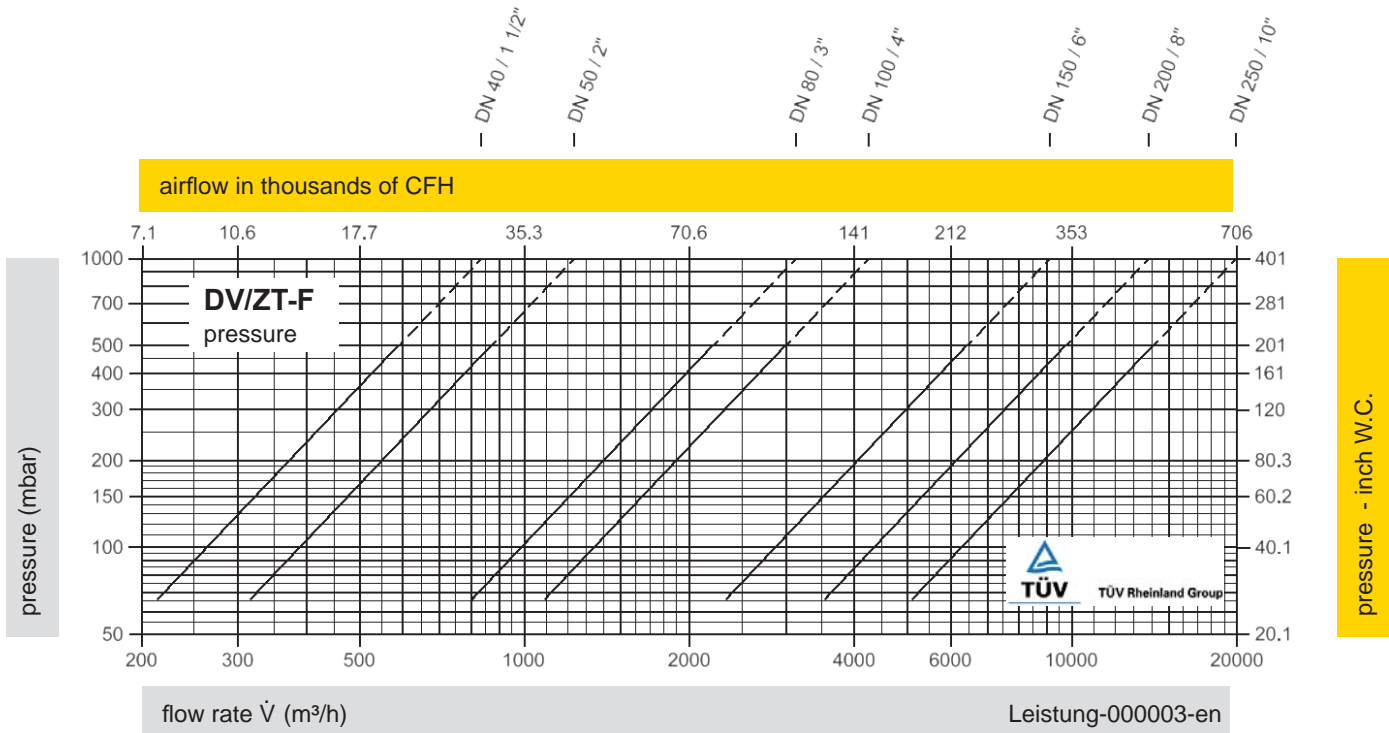

The flow capacity charts have been determined with a calibrated and TÜV certified flow capacity test rig. Volume flow \dot{V} in (m³/h) and CFH refer to the standard reference conditions of air ISO 6358 (20°C, 1bar). Conversion to other densities and temperatures refer to Vol. 1: "Technical Fundamentals".

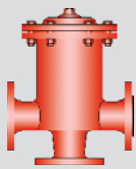

Pressure and Vacuum Relief Valve, In-Line



PROTEGO® DV/ZU

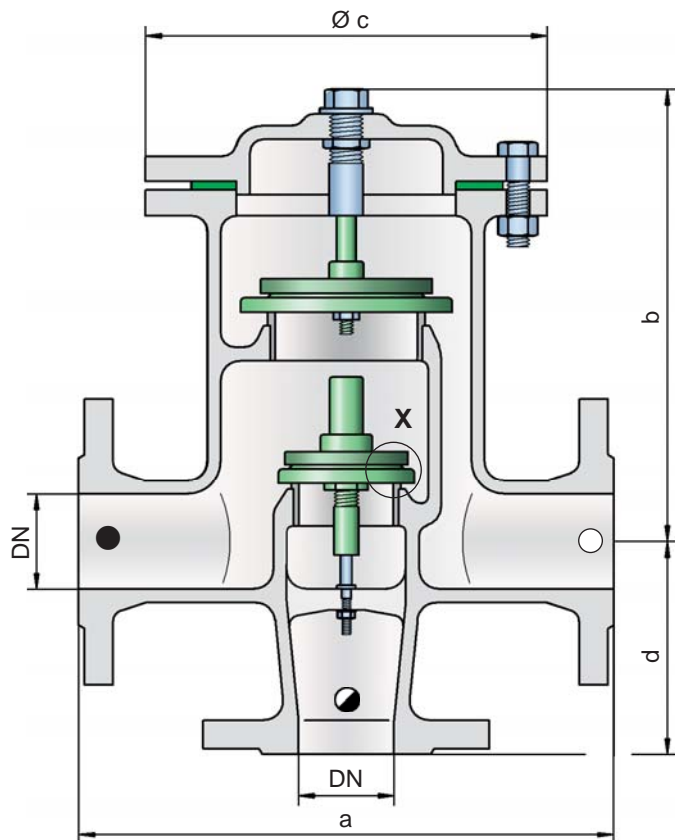

Detail X

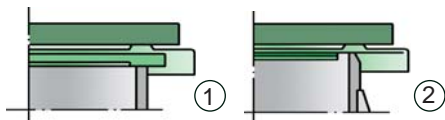

● = Tank connection

◐ = Inbreathing

○ = Outbreathing

Settings:

Pressure: +2.0 mbar up to +60 mbar
+0.8 inch W.C. up to +24 inch W.C.

Vacuum: -3.5 mbar up to -50 mbar
-1.4 inch W.C. up to -20 inch W.C.

For higher set pressure refer to type DV/ZU-F.

Lower set vacuum upon request.

Function and Description

The PROTEGO® in-line valve DV/ZU is a state-of-the-art pressure and vacuum relief valve with separate flange connections for pressure and vacuum breathing. Typically the valve is installed in the in- and outbreathing lines of tanks, vessels and process apparatus to protect against unallowable high and low pressure. The valve prevents emission losses almost up to the set pressure and prevents air intake almost up to set vacuum. The valve is designed so that in cases in which the set pressure is exceeded the vapours are vented into a discharge pipe (e.g.

vent header). When the set vacuum is exceeded atmospheric air is pulled into the system. Due to its design the vacuum valve pallet is one size smaller than the pressure valve pallet.

The device will start to open as soon as the set pressure is reached and only requires 10% overpressure to full lift. Continuous investments into research and development have allowed PROTEGO® to develop a low pressure valve which has the same opening characteristic as a high pressure safety relief valve. This "full lift type" technology allows the valve to be set just 10% below the maximum allowable working pressure or vacuum (MAWP or MAWV) of the tank and still safely vent the required mass flow. The opening characteristic of the pressure and vacuum side is basically the same. However, the inbreathing will start as soon as the differential pressure between the connected inbreathing line and the tank is greater than the set pressure of the vacuum pallet. Due to our highly developed manufacturing technology the tank pressure is maintained up to set pressure with a tightness that is far superior to the conventional standard. This feature is facilitated by valve seats made of high quality stainless steel and with individually lapped valve pallets (1) or with an air cushion seal (2) in conjunction with high quality FEP diaphragm. The valve pallets are also available with a PTFE seal to prevent the valve pallets from sticking when sticky products are used and to enable the use of corrosive fluids. After the excess pressure is discharged or vacuum is balanced, the valve reseats and provides a tight seal.

The optimized fluid dynamic design of the vent body and vent pallet is a result of many years of research work, which allow a stable operation of the valve pallet and optimized performance resulting in reduction of product losses.

Special Features and Advantages

- "full lift type" technology valve utilizes only 10% overpressure to reach full lift
- high performance seal reducing product loss below EPA's 500ppm rule preventing environmental pollution
- based on 10% technology the set pressure is close to the opening pressure which results in best possible pressure management of the system compared to conventional 40%- or 100%- technology valves
- optimized flow performance, which reduces capital cost to a minimum as smaller sized valves may be used
- separate flange connection for in- and out-breathing line
- can be installed in explosion hazardous areas
- housing designed to 150 psi (PN 10)
- maintenance friendly design



Vents - 10% Technology
(Flyer pdf)



Leak Rate/10% Technology
(Flyer pdf)



Coated Devices
(Flyer pdf)



The optimised valve pallet
(Flyer pdf)

Designs and Specifications

The valve pallets are weight loaded. **Higher set pressures are achieved by using spring loaded type DV/ZU-F.**

Two different designs are available:

In-line pressure and vacuum relief valve, standard design **DV/ZU - □**

In-line pressure and vacuum relief valve with heating jacket **DV/ZU - □H**

Additional special devices available upon request

Within piping systems the influence of backpressure has to be considered in deciding the set pressure and opening characteristics. For special design solutions (e.g. partial load operation) the valve can be supplied with standard valve pallets (with proportional opening function).

Table 1: Dimensions

Dimensions in mm / inches

To select the nominal size (DN), please use the flow capacity charts on the following pages

DN	40 / 1 1/2"	50 / 2"	80 / 3"	100 / 4"	150 / 6"
a	280 / 11.02	280 / 11.02	340 / 13.39	390 / 15.35	520 / 20.47
b	230 / 9.06	230 / 9.06	240 / 9.45	290 / 11.42	330 / 12.99
c	210 / 8.27	210 / 8.27	280 / 11.02	310 / 12.20	390 / 15.35
d	165 / 6.50	165 / 6.50	200 / 7.87	240 / 9.45	300 / 11.81

Larger sizes upon request

Dimensions for pressure and vacuum relief valve with heating jacket upon request

Table 2: Material selection for housing

Design	A	B	Option: Housing with ECTFE-lining Special materials upon request
Housing	Steel	Stainless Steel	
Heating jacket (DV/ZU-H-...)	Steel	Stainless Steel	
Valve seat	Stainless Steel	Stainless Steel	
Gasket	PTFE	PTFE	

Table 3: Material selection for pressure valve pallet

Design	A	B	C	D	Special materials upon request For higher set pressures refer to type DV/ZU-F
Pressure range (mbar) (inch W.C.)	+2.0 up to +3.5 +0.8 up to +1.4	>+3.5 up to +14 >+1.4 up to +5.6	>+14 up to +60 >+5.6 up to +24	>+14 up to +60 >+5.6 up to +24	
Valve pallet	Aluminium	Stainless Steel	Stainless Steel	Stainless Steel	
Sealing	FEP	FEP	Metal to Metal	PTFE	

Table 4: Material selection for vacuum valve pallet

Design	A	B	C	D	E	F
Pressure range (mbar) (inch W.C.)	-3.5 up to -5.0 -1.4 up to -2.0	<-5.0 up to -14 <-2.0 up to -5.6	<-14 up to -35 <-5.6 up to -14	<-35 up to -50 <-14 up to -20	<-14 up to -35 <-5.6 up to -14	<-35 up to -50 <-14 up to -20
Valve pallet	Aluminium	Stainless Steel	Stainless Steel	Stainless Steel	Stainless Steel	Stainless Steel
Sealing	FEP	FEP	Metal to Metal	Metal to Metal	PTFE	PTFE

Special materials and lower set vacuum upon request

Table 5: Flange connection type

EN 1092-1; Form B1	other types upon request
ASME B16.5; 150 lbs RFSF	



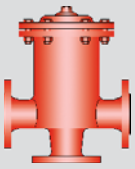

Pressure and Vacuum Relief Valve, In-Line

Flow Capacity Charts

PROTEGO® DV/ZU

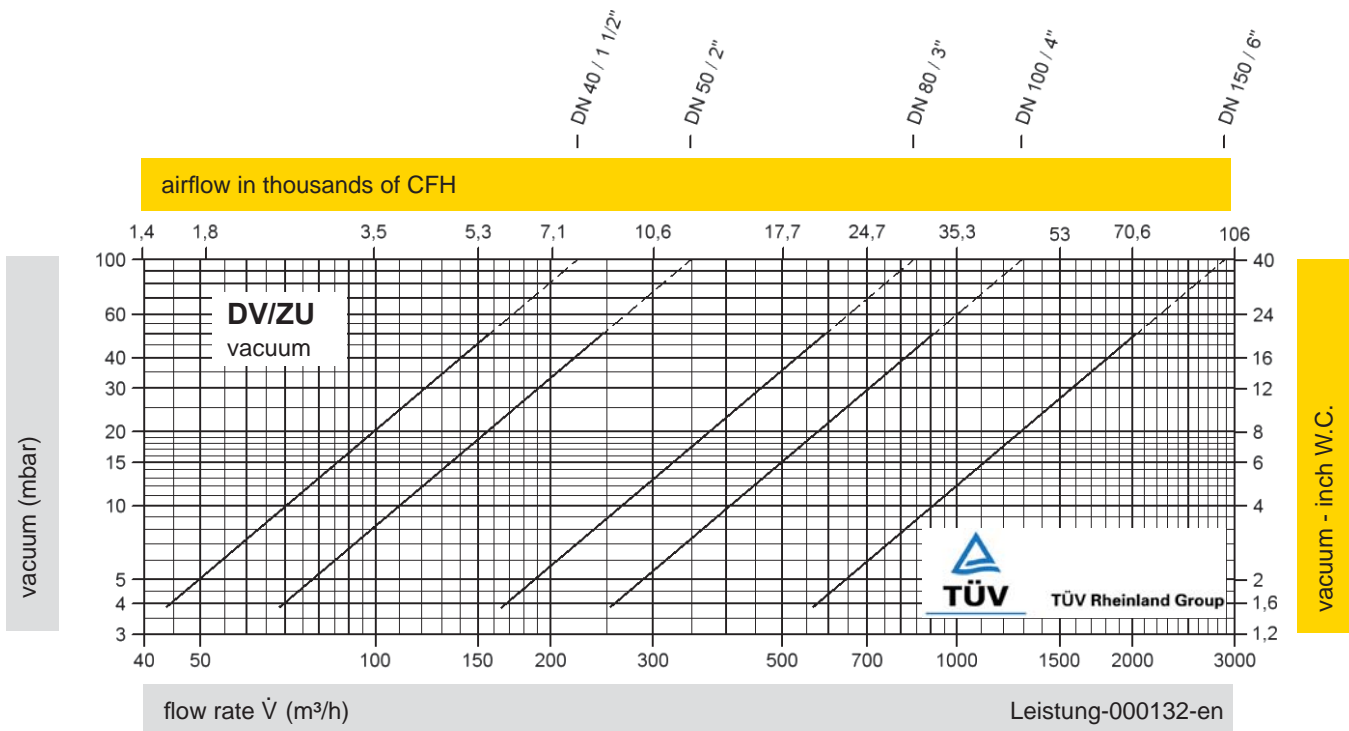
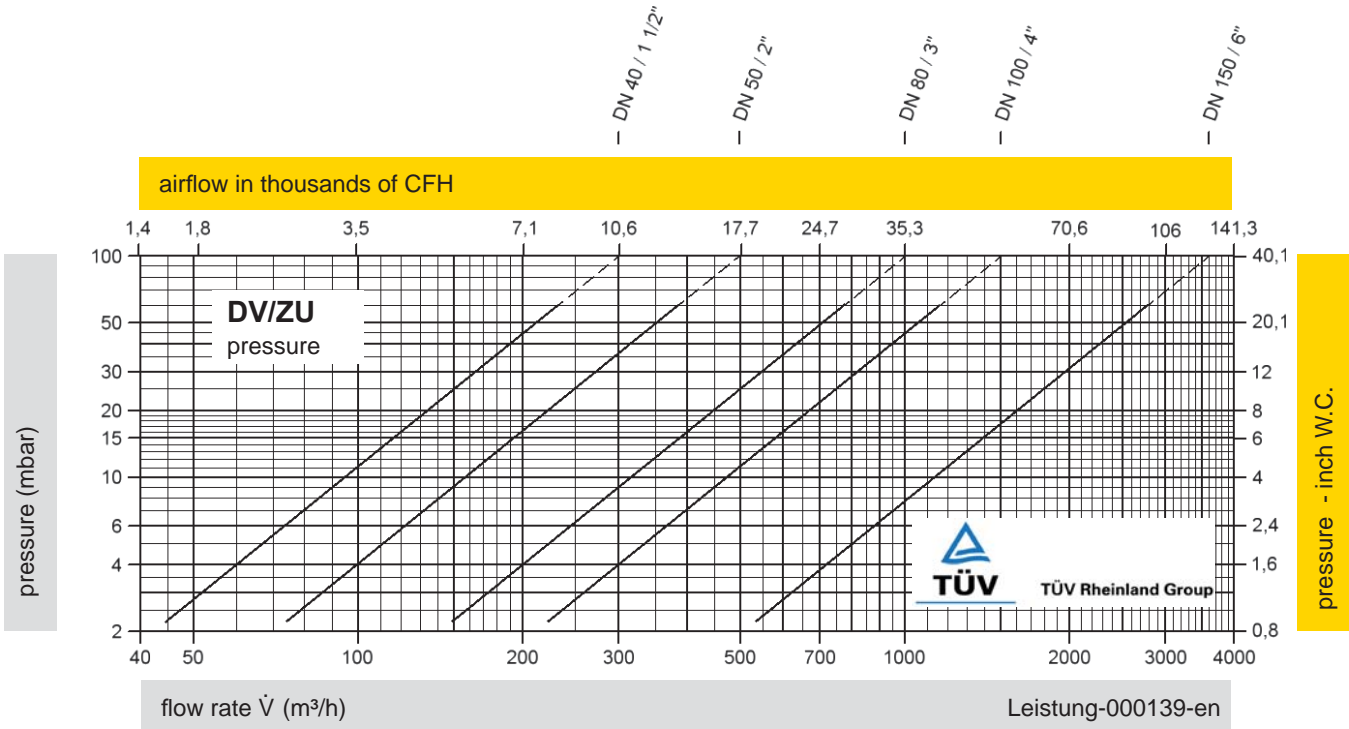

The flow capacity charts have been determined with a calibrated and TÜV certified flow capacity test rig. Volume flow \dot{V} in (m³/h) and CFH refer to the standard reference conditions of air ISO 6358 (20°C, 1bar). Conversion to other densities and temperatures refer to Vol. 1: "Technical Fundamentals".

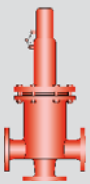

Pressure and Vacuum Relief Valve, In-Line



PROTEGO® DV/ZU-F

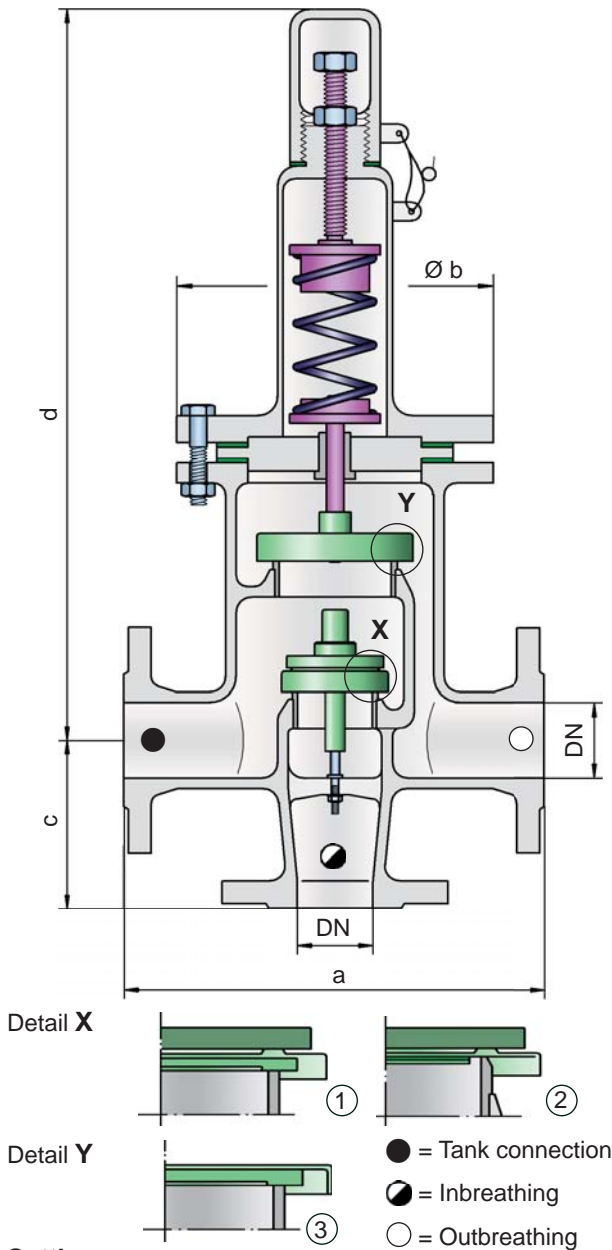

Settings:

Pressure:	+60 mbar	up to +500 mbar
	+24 inch W.C.	up to +200 inch W.C.
Vacuum:	-3.5 mbar	up to -50 mbar
	-1.4 inch W.C.	up to -20 inch W.C.
Vacuum:	-3.5 mbar	up to -14 mbar
	-1.4 inch W.C.	up to -5.6 inch W.C.
	by set pressure up to +150 mbar / +60 inch W.C.	

For lower set pressure refer to type DV/ZU.
Higher set pressure and lower set vacuum upon request.

Function and Description

The PROTEGO® in-line valve DV/ZU is a state-of-the-art pressure and vacuum relief valve with separate flange connections for pressure and vacuum breathing. Typically the valve is installed in the in- and out-breathing lines of tanks, vessels and process apparatus to protect against unallowable high and low pressure. The valve prevents emission losses almost up to the

set pressure and prevents air intake almost up to set vacuum. The valve is designed so that in cases in which the set pressure is exceeded the vapours are vented into a discharge pipe (e.g. vent header). When the set vacuum is exceeded atmospheric air is pulled into the system. Due to its design the vacuum valve pallet is one size smaller than the pressure valve pallet. The spring loaded design of the pressure pallet allows achieving higher set pressures.

The device will start to open as soon as the set pressure is reached and only requires 10% overpressure to full lift. Continuous investments into research and development have allowed PROTEGO® to develop a low pressure valve which has the same opening characteristic as a high pressure safety relief valve. This "full lift type" technology allows the valve to be set just 10% below the maximum allowable working pressure or vacuum (MAWP or MAWV) of the tank and still safely vent the required mass flow. The opening characteristic of the pressure and vacuum side is basically the same. However, the inbreathing will start as soon as the differential pressure between the connected inbreathing line and the tank is greater than the set pressure of the vacuum pallet. Due to our highly developed manufacturing technology the tank pressure is maintained up to set pressure with a tightness that is far superior to the conventional standard. This feature is facilitated by valve seats made of high quality stainless steel and with individually lapped valve pallets (1), (3) or with an air cushion seal (2) in conjunction with high quality FEP diaphragm and a rugged valve body. After the excess pressure is discharged or the vacuum is balanced, the valve reseats and provides a tight seal.

The optimized fluid dynamic design of the valve body and valve pallet is a result of many years of research work, which allow a stable operation of the valve pallet and optimized performance resulting in reduction of product losses.

Special Features and Advantages

- "full lift type" technology valve utilizes only 10% overpressure to reach full lift
- high performance seal reducing product loss below EPA's 500ppm rule preventing environmental pollution
- based on 10% technology the set pressure is close to the opening pressure which results in best possible pressure management of the system compared to conventional 40%- or 100%- technology valves
- optimized flow performance, which reduces capital cost to a minimum as smaller sized valves may be used
- separate flange connection for in- and outbreathing line
- can be installed in explosion hazardous areas
- housing designed to 150 psi (PN 10)
- spring loaded pressure side to achieve higher set pressures
- maintenance friendly design



Vents - 10% Technology
(Flyer pdf)



Leak Rate/10% Technology
(Flyer pdf)



Coated Devices
(Flyer pdf)



The optimised valve pallet
(Flyer pdf)

Designs and Specifications

The pressure valve pallet is spring loaded, the vacuum valve pallet weight loaded. Lower set pressures for the pressure side are achieved through weight loaded type DV/ZU.

Two different designs are available:

In-line pressure and vacuum relief valve,
standard design

DV/ZU-F

In-line pressure and vacuum relief valve with
heating jacket

DV/ZU-F - H

Additional special devices available upon request

Within piping systems the influence of backpressure has to be considered in deciding the set pressure and opening characteristics. For special design solutions (e.g. partial load operation) the valve can be supplied with standard valve pallets (with proportional opening function).



Spring-loaded PV-Valves
Maintenance-friendly design (Flyer pdf)

Table 1: Dimensions

Dimensions in mm / inches

To select the nominal size (DN), please use the flow capacity charts on the following pages

DN	40 / 1 ½"	50 / 2"	80 / 3"	100 / 4"	150 / 6"
a	280 / 11.02	280 / 11.02	340 / 13.39	390 / 15.35	520 / 20.47
b	210 / 8.27	210 / 8.27	280 / 11.02	310 / 12.20	390 / 15.35
c	165 / 6.50	165 / 6.50	200 / 7.87	240 / 9.45	300 / 11.81
d	565 / 22.24	565 / 22.24	675 / 26.57	805 / 31.69	1070 / 42.13

Larger sizes upon request

Dimensions for pressure and vacuum relief valve with heating jacket upon request

Table 2: Material selection for housing

Design	A	B	
Housing	Steel	Stainless Steel	Option: Housing with ECTFE-lining
Heating jacket (DV/ZU-F-H-...)	Steel	Stainless Steel	
Valve seat	Stainless Steel	Stainless Steel	Special materials upon request
Gasket	PTFE	PTFE	

Table 3: Material of pressure valve pallet

Design	A	
Pressure range (mbar) (inch W.C.)	>+60 up to +500 >+24 up to +200	Special materials upon request
Valve pallet	Stainless Steel	For lower set pressure use type DV/ZU
Sealing	Metal to Metal	Higher set pressure and lower set vacuum upon request
Pressure spring	Stainless Steel	

Table 4: Material selection for vacuum valve pallet

Design	A*	B*	C	D	
Pressure range (mbar) (inch W.C.)	-3.5 up to -5.0 -1.4 up to -2.0	<-5.0 up to -14 <-2.0 up to -5.6	<-14 up to -35 <-5.6 up to -14	<-35 up to -50 <-14 up to -20	Special materials and lower set vacuum upon request
Valve pallet	Aluminium	Stainless Steel	Stainless Steel	Stainless Steel	
Sealing	FEP	FEP	Metal to Metal	Metal to Metal	

* by set pressure up to +150 mbar / +60 inch W.C.

Table 5: Flange connection type

EN 1092-1; Form B1	other types upon request
ASME B16.5; 150 lbs RFSF	



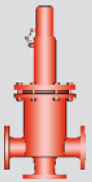

Pressure and Vacuum Relief Valve, In-Line

Flow Capacity Charts

PROTEGO® DV/ZU-F

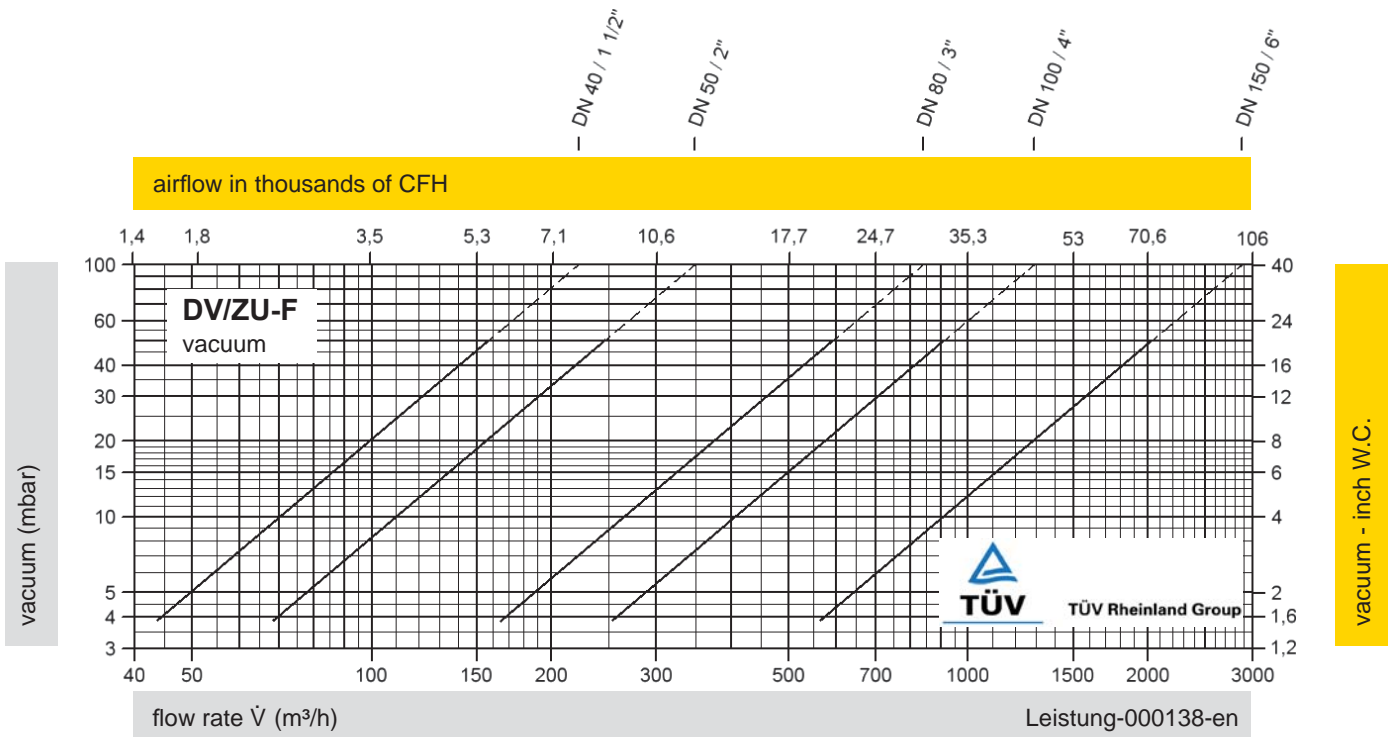
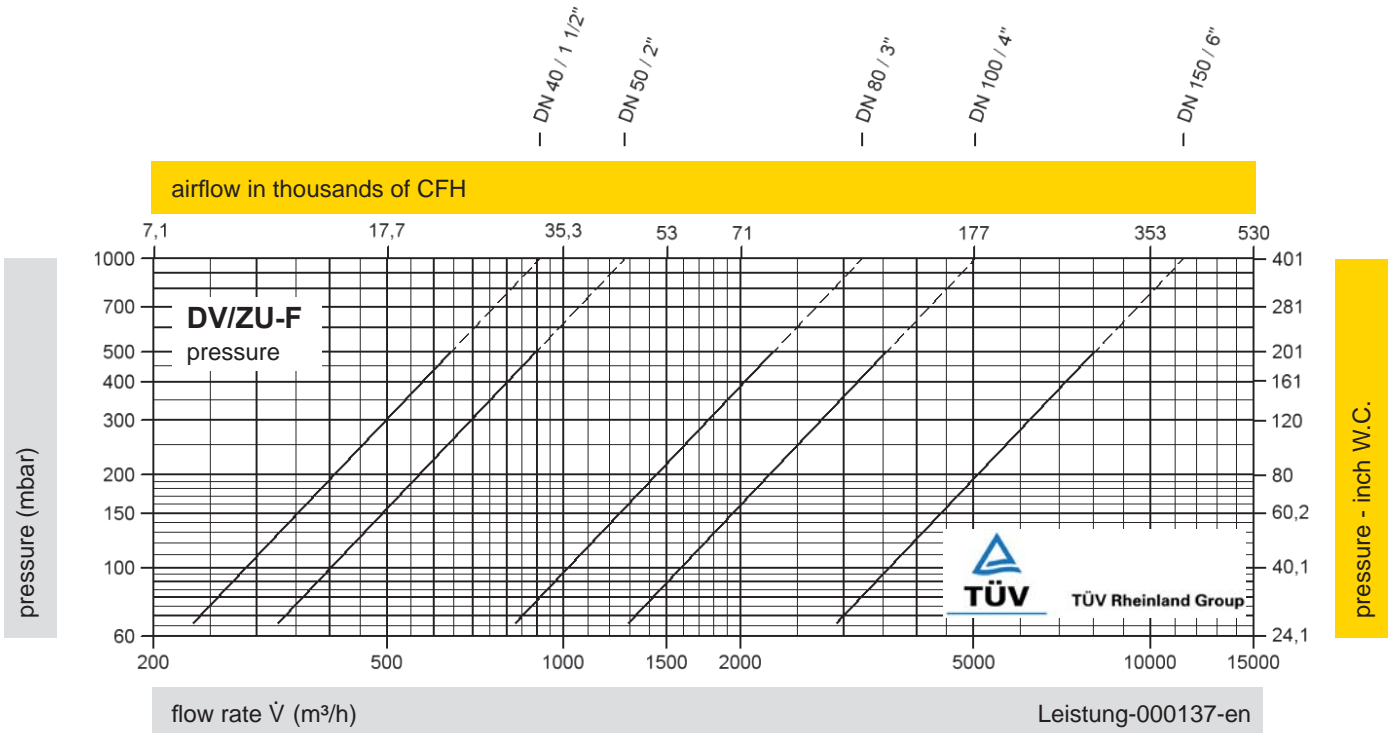

The flow capacity charts have been determined with a calibrated and TÜV certified flow capacity test rig. Volume flow \dot{V} in (m³/h) and CFH refer to the standard reference conditions of air ISO 6358 (20°C, 1bar). Conversion to other densities and temperatures refer to Vol. 1: "Technical Fundamentals".

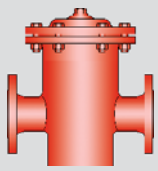

Pressure and Vacuum Relief Valve, In-Line



PROTEGO® DV/ZW

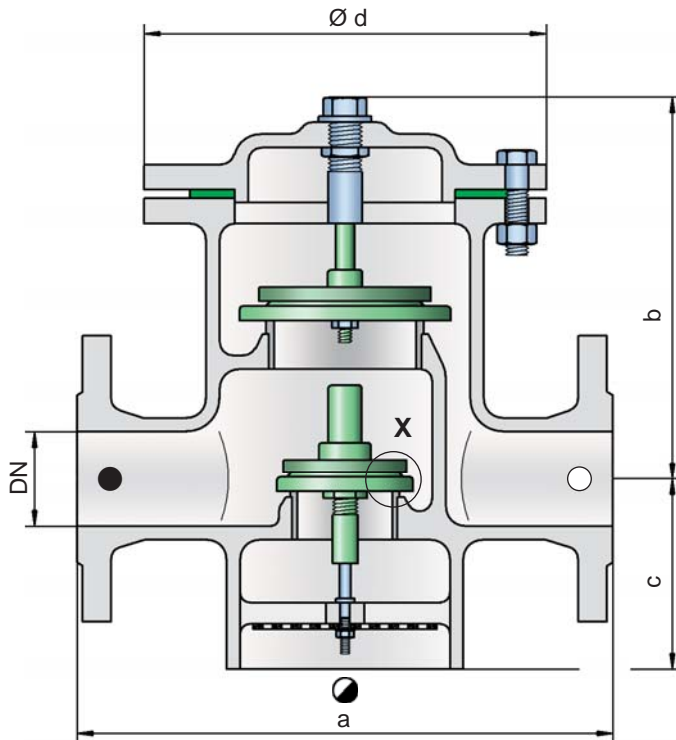

Detail X

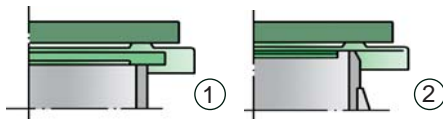

● = Tank connection

◐ = Inbreathing

○ = Outbreathing

Settings:

Pressure: +2.0 mbar up to +60 mbar
+0.8 inch W.C. up to +24 inch W.C.

Vacuum: -3.5 mbar up to -50 mbar
-1.4 inch W.C. up to -20 inch W.C.

For higher set pressure refer to type DV/ZW-F.

Lower set vacuum upon request.

Function and Description

The PROTEGO® in-line valve DV/ZW is a state-of-the-art pressure and vacuum relief valve with separate flange connections for use in a vent line. Typically the valve is installed in the in- and outbreathing lines of tanks, vessels and process apparatus to protect against unallowable high and low pressure. The valve prevents emission losses almost up to the set pressure and prevents air intake almost up to set vacuum. The valve is designed so that in cases in which the set pressure is exceeded the vapours are vented into a discharge pipe (e.g. vent header). When the set vacuum is exceeded atmospheric air is pulled into the system. Due to its design the vacuum valve pallet is one size smaller than the pressure valve pallet.

The device will start to open as soon as the set pressure is reached and only requires 10% overpressure to full lift. Continuous investments into research and development have allowed PROTEGO® to develop a low pressure valve which has the same opening characteristic as a high pressure safety relief valve. This "full lift type" technology allows the valve to be set just 10% below the maximum allowable working pressure or vacuum (MAWP or MAWV) of the tank and still safely vent the required mass flow. The opening characteristic of the pressure and vacuum side is basically the same. However, the inbreathing will start as soon as the differential pressure between the atmospheric pressure and the tank is greater than the set pressure of the vacuum pallet. Due to our highly developed manufacturing technology the tank pressure is maintained up to set pressure with a tightness that is far superior to the conventional standard. This feature is facilitated by valve seats made of high quality stainless steel and with individually lapped valve pallets (1) or with an air cushion seal (2) in conjunction with high quality FEP diaphragm. The valve pallets are also available with a PTFE seal to prevent the valve pallets from sticking when sticky products are used and to enable the use of corrosive fluids. After the excess pressure is discharged or vacuum is balanced, the valve reseats and provides a tight seal.

The optimized fluid dynamic design of the valve body and valve pallet is a result of many years of research work, which allow a stable operation of the valve pallet and optimized performance resulting in reduction of product losses.

Special Features and Advantages

- "full lift type" technology valve utilizes only 10% overpressure to reach full lift
- high performance seal reducing product loss below EPA's 500ppm rule preventing environmental pollution
- based on 10% technology the set pressure is close to the opening pressure which results in best possible pressure management of the system compared to conventional 40%- or 100%- technology valves
- optimized flow performance, which reduces capital cost to a minimum as smaller sized valves may be used
- flange connection for discharge line
- can be installed in explosion hazardous areas
- housing designed to 150 psi (PN 10)
- maintenance friendly design



Vents - 10% Technology
(Flyer pdf)



Leak Rate/10% Technology
(Flyer pdf)



Coated Devices
(Flyer pdf)



The optimised valve pallet
(Flyer pdf)

Designs and Specifications

The valve pallets are weight loaded. **Higher set pressures are achieved by using spring loaded type DV/ZW-F.**

Two different designs are available:

In-line pressure and vacuum relief valve, **DV/ZW - □**
standard design

In-line pressure and vacuum relief valve with **DV/ZW - □H**
heating jacket

Additional special devices available upon request.

Within piping systems the influence of backpressure has to be considered in deciding the set pressure and opening characteristics. For special design solutions (e.g. partial load operation) the valve can be supplied with standard valve pallets (with proportional opening function).

Table 1: Dimensions

Dimensions in mm / inches

To select the nominal size (DN), please use the flow capacity charts on the following pages

DN	40 / 1 1/2"	50 / 2"	80 / 3"	100 / 4"	150 / 6"
a	280 / 11.02	280 / 11.02	340 / 13.39	390 / 15.35	520 / 20.47
b	230 / 9.06	230 / 9.06	240 / 9.45	290 / 11.42	330 / 12.99
c	85 / 3.35	85 / 3.35	125 / 4.92	140 / 5.51	185 / 7.28
d	210 / 8.27	210 / 8.27	280 / 11.02	310 / 12.20	390 / 15.35

Larger sizes upon request

Dimensions for pressure and vacuum relief valve with heating jacket upon request

Table 2: Material selection for housing

Design	A	B	
Housing	Steel	Stainless Steel	Option: Housing with ECTFE-lining Special materials upon request
Heating jacket (DV/ZW-H-...)	Steel	Stainless Steel	
Valve seat	Stainless Steel	Stainless Steel	
Gasket	PTFE	PTFE	

Table 3: Material selection for pressure valve pallet

Design	A	B	C	D	
Pressure range (mbar) [inch W.C.]	+2.0 up to +3.5 +0.8 up to +1.4	>+3.5 up to +14 >+1.4 up to +5.6	>+14 up to +60 >+5.6 up to +24	>+14 up to +60 >+5.6 up to +24	Special materials upon request For higher set pressures refer to type DV/ZW-F
Valve pallet	Aluminium	Stainless Steel	Stainless Steel	Stainless Steel	
Sealing	FEP	FEP	Metal to Metal	PTFE	

Table 4: Material selection for vacuum valve pallet

Design	A	B	C	D	E	F
Pressure range (mbar) (inch W.C.)	-3.5 up to -5.0 -1.4 up to -2.0	<-5.0 up to -14 <-2.0 up to -5.6	<-14 up to -35 <-5.6 up to -14	<-35 up to -50 <-14 up to -20	<-14 up to -35 <-5.6 up to -14	<-35 up to -50 <-14 up to -20
Valve pallet	Aluminium	Stainless Steel	Stainless Steel	Stainless Steel	Stainless Steel	Stainless Steel
Sealing	FEP	FEP	Metal to Metal	Metal to Metal	PTFE	PTFE

Special materials and lower set vacuum upon request

Table 5: Flange connection type

EN 1092-1; Form B1	other types upon request
ASME B16.5; 150 lbs RFSF	



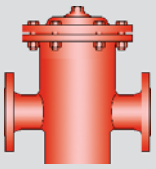

Pressure and Vacuum Relief Valve, In-Line

Flow Capacity Charts

PROTEGO® DV/ZW

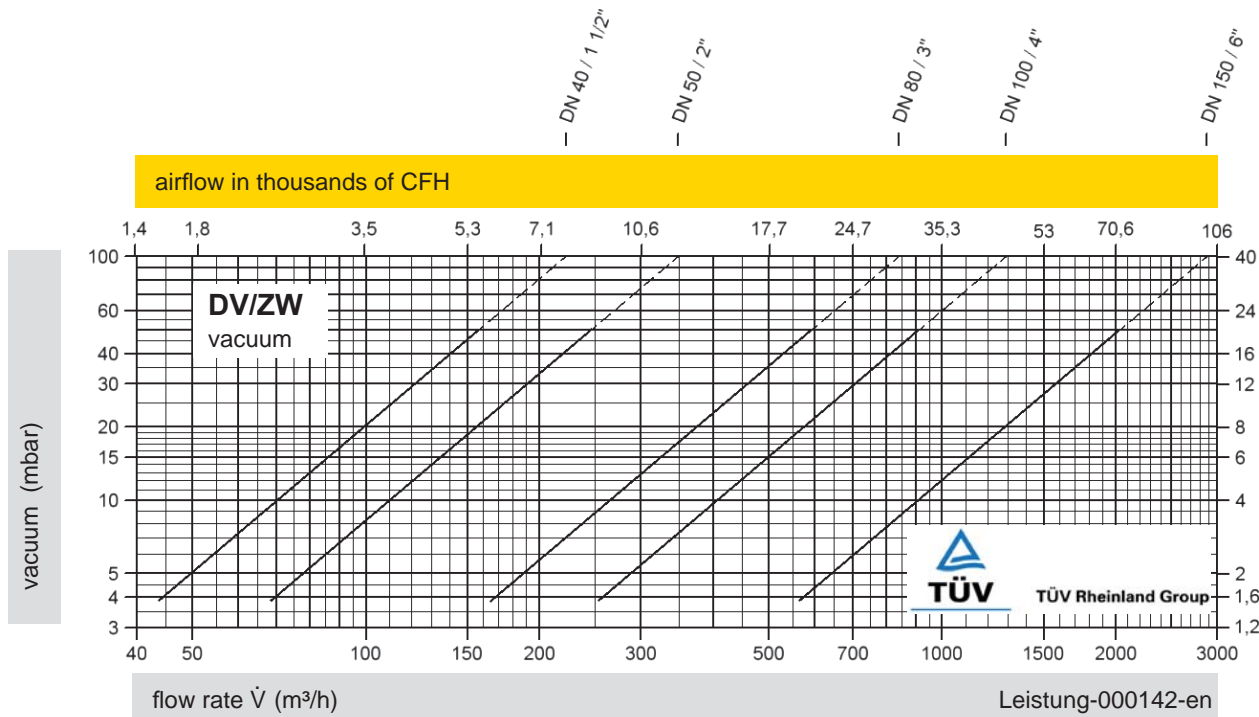
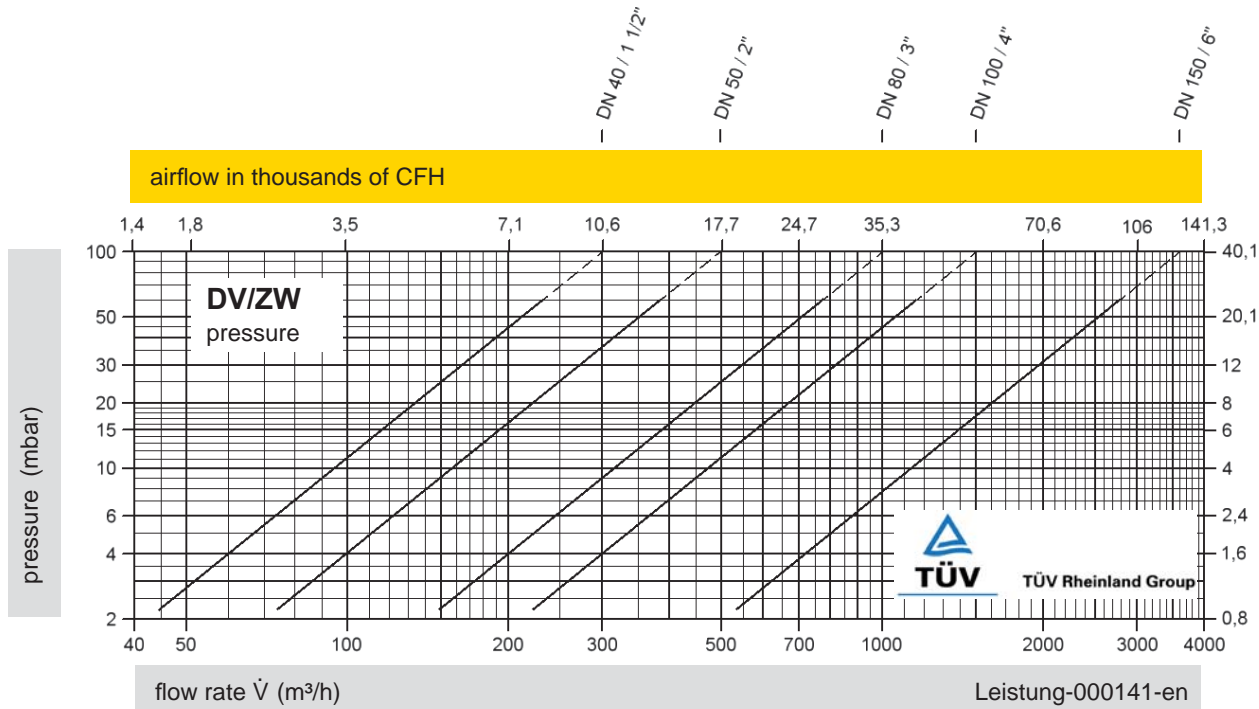

The flow capacity charts have been determined with a calibrated and TÜV certified flow capacity test rig. Volume flow \dot{V} in (m³/h) and CFH refer to the standard reference conditions of air ISO 6358 (20°C, 1bar). Conversion to other densities and temperatures refer to Vol. 1: "Technical Fundamentals".

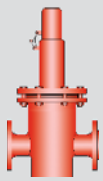

Pressure and Vacuum Relief Valve, In-Line



PROTEGO® DV/ZW-F

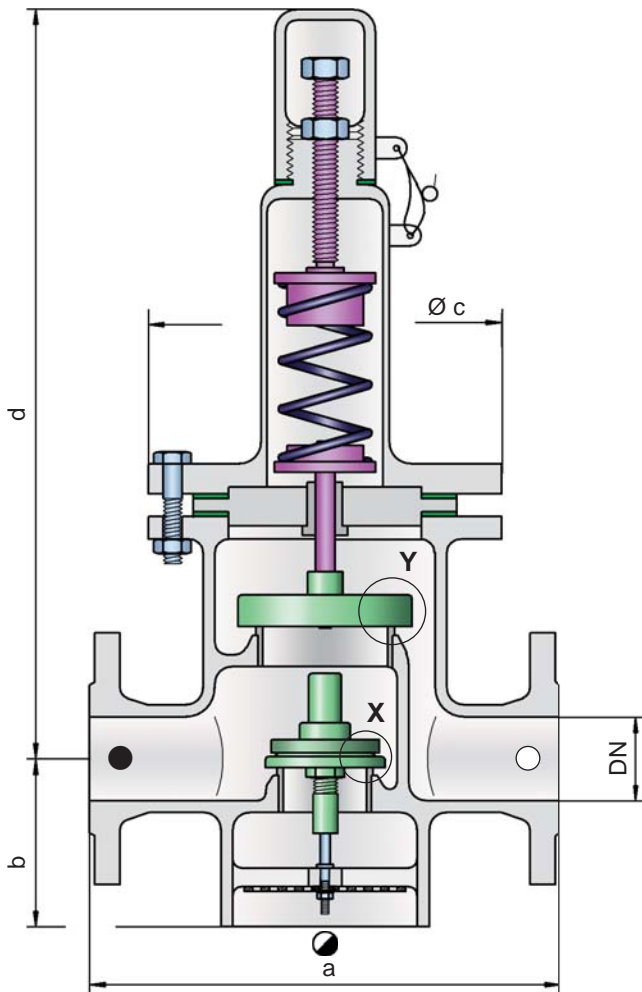

Detail X

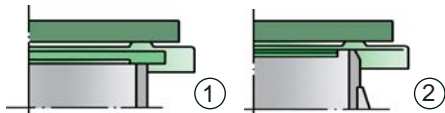

Detail Y

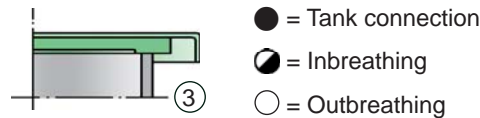

- = Tank connection
- ◐ = Inbreathing
- = Outbreathing

Settings:

- Pressure:** +60 mbar up to +500 mbar
+24 inch W.C. up to +200 inch W.C.
- Vacuum:** -3.5 mbar up to -50 mbar
-1.4 inch W.C. up to -20 inch W.C.
- Vacuum:** -3.5 mbar up to -14 mbar
-1.4 inch W.C. up to -5.6 inch W.C.
by set pressure up to +150 mbar / +60 inch W.C.

For lower set pressure refer to type DV/ZW.
Higher set pressure and lower set vacuum upon request.

Function and Description

The PROTEGO® in-line valve DV/ZW-F is a state-of-the-art pressure and vacuum relief valve with flanged connections for use in a vent line. Typically the valve is installed in the in- and out-breathing lines of tanks, vessels and process apparatus to protect against unallowable high and low pressure. The valve

prevents emission losses almost up to the set pressure and prevents air intake almost up to set vacuum. The valve is designed so that in cases in which the set pressure is exceeded the vapours are vented into a discharge pipe (e.g. vent header). When the set vacuum is exceeded atmospheric air breathes into the system. Due to its design the vacuum valve pallet is one size smaller than the pressure valve pallet. The spring loaded design of the pressure pallet allows higher set pressures than the DV/ZW model does.

The device will start to open as soon as the set pressure is reached and only requires 10% overpressure to full lift. Continuous investments into research and development have allowed PROTEGO® to develop a low pressure valve which has the same opening characteristic as a high pressure safety relief valve. This "full lift type" technology allows the valve to be set just 10% below the maximum allowable working pressure or vacuum (MAWP or MAWV) of the tank and still safely vent the required mass flow. The inbreathing will start as soon as the differential pressure between the atmospheric pressure and the tank is greater than the set pressure of the vacuum pallet. Due to our highly developed manufacturing technology the tank pressure is maintained up to set pressure with a tightness that is far superior to the conventional standard. This feature is facilitated by valve seats made of high quality stainless steel and with individually lapped valve pallets (1), (3) or with an air cushion seal (2) in conjunction with high quality FEP diaphragm and a rugged valve body. After the excess pressure is discharged or the vacuum is balanced, the valve reseats and provides a tight seal.

The optimized fluid dynamic design of the valve body and valve pallet is a result of many years of research work, which allow a stable operation of the valve pallet and optimized performance resulting in reduction of product losses.

Special Features and Advantages

- "full lift type" technology vent utilizes only 10% overpressure to reach full lift
- high performance seal reducing product loss below EPA's 500ppm rule preventing environmental pollution
- based on 10% technology the set pressure is close to the opening pressure which results in best possible pressure management of the system compared to conventional 40%- or 100%- technology valves
- optimized flow performance, which reduces capital cost to a minimum as smaller sized valves may be used
- flange connection for discharge line
- can be installed in explosion hazardous areas
- housing designed to 150 psi (PN 10)
- spring loaded design on pressure side to achieve higher set pressures
- maintenance friendly design



Vents - 10% Technology
(Flyer pdf)



Leak Rate/10% Technology
(Flyer pdf)



Coated Devices
(Flyer pdf)



The optimised valve pallet
(Flyer pdf)

Designs and Specifications

The pressure valve pallet is spring loaded, the vacuum valve pallet weight loaded. Lower set pressures for the pressure side are achieved through weight loaded type DV/ZW.

Two different designs are available:

In-line pressure and vacuum relief valve, standard design **DV/ZW-F**

In-line pressure and vacuum relief valve with heating jacket **DV/ZW-F - H**

Additional special devices available upon request

Within piping systems the influence of backpressure has to be considered in deciding the set pressure and opening characteristics. For special design solutions (e.g. partial load operation) the valve can be supplied with standard valve pallets (with proportional opening function).



Spring-loaded PV-Valves
Maintenance-friendly design (Flyer pdf)

Table 1: Dimensions

Dimensions in mm / inches

To select the nominal size (DN), please use the flow capacity charts on the following pages

DN	40 / 1 1/2"	50 / 2"	80 / 3"	100 / 4"	150 / 6"
a	280 / 11.02	280 / 11.02	340 / 13.39	390 / 15.35	520 / 20.47
b	85 / 3.35	85 / 3.35	125 / 4.92	140 / 5.51	185 / 7.28
c	210 / 8.27	210 / 8.27	280 / 11.02	310 / 12.20	390 / 15.35
d	565 / 22.24	565 / 22.24	675 / 26.57	805 / 31.69	1070 / 42.13

Larger sizes upon request

Dimensions for pressure and vacuum relief valve with heating jacket upon request

Table 2: Material selection for housing

Design	A	B	
Housing	Steel	Stainless Steel	Option: Housing with ECTFE-lining
Heating jacket (DV/ZW-F-H-...)	Steel	Stainless Steel	
Valve seat	Stainless Steel	Stainless Steel	Special materials upon request
Gasket	PTFE	PTFE	

Table 3: Material of pressure valve pallet

Design	A	
Pressure range (mbar) (inch W.C.)	>+60 up to +500 >+24 up to +200	Special materials upon request
Valve pallet	Stainless Steel	For lower set pressure use type DV/ZW
Sealing	Metal to Metal	Higher set pressure and lower set vacuum upon request.
Pressure spring	Stainless Steel	

Table 4: Material selection for vacuum valve pallet

Design	A*	B*	C	D	
Pressure range (mbar) (inch W.C.)	-3.5 up to -5.0 -1.4 up to -2.0	<-5.0 up to -14 <-2.0 up to -5.6	<-14 up to -35 <-5.6 up to -14	<-35 up to -50 <-14 up to -20	Special materials and lower set vacuum upon request
Valve pallet	Aluminium	Stainless Steel	Stainless Steel	Stainless Steel	
Sealing	FEP	FEP	Metal to Metal	Metal to Metal	

* by set pressure up to +150 mbar / +60 inch W.C.

Table 5: Flange connection type

EN 1092-1; Form B1	other types upon request
ASME B16.5; 150 lbs RFSF	



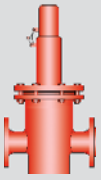

Pressure and Vacuum Relief Valve, In-Line

Flow Capacity Charts

PROTEGO® DV/ZW-F

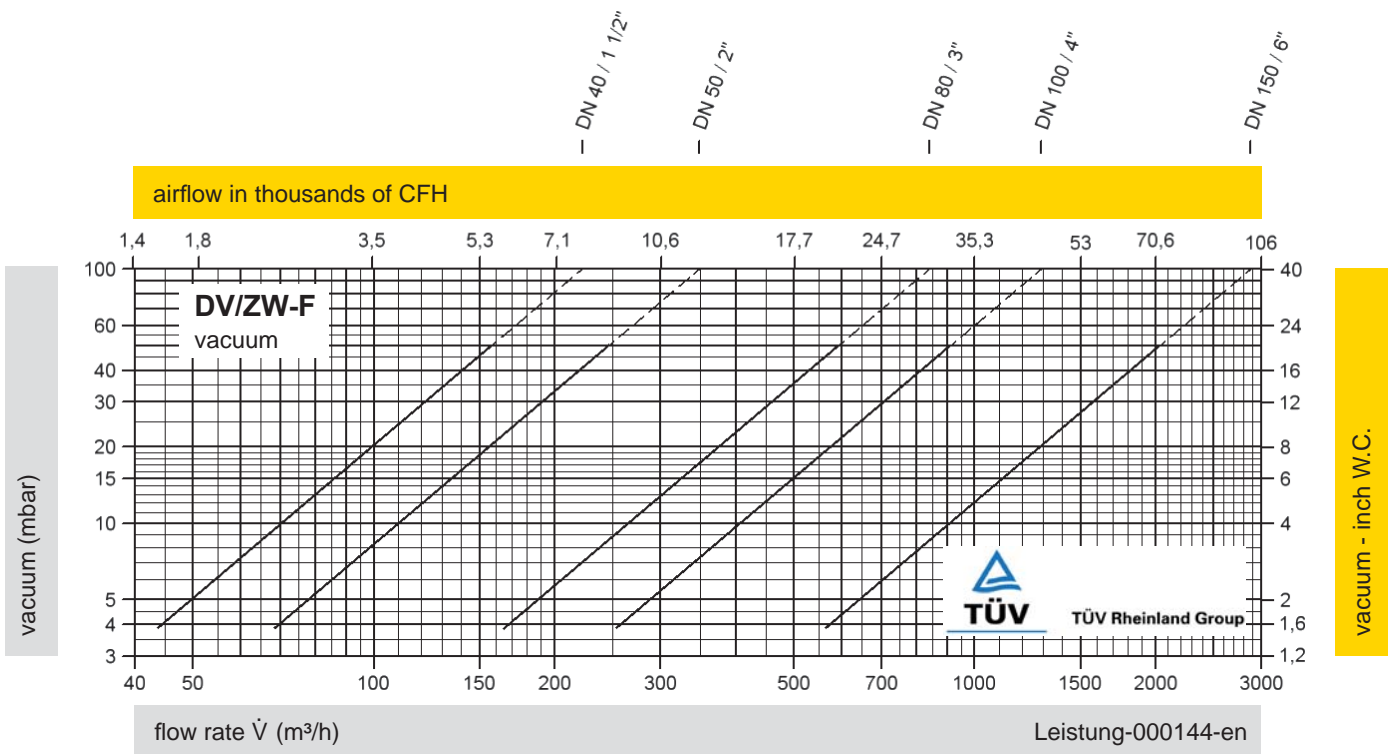
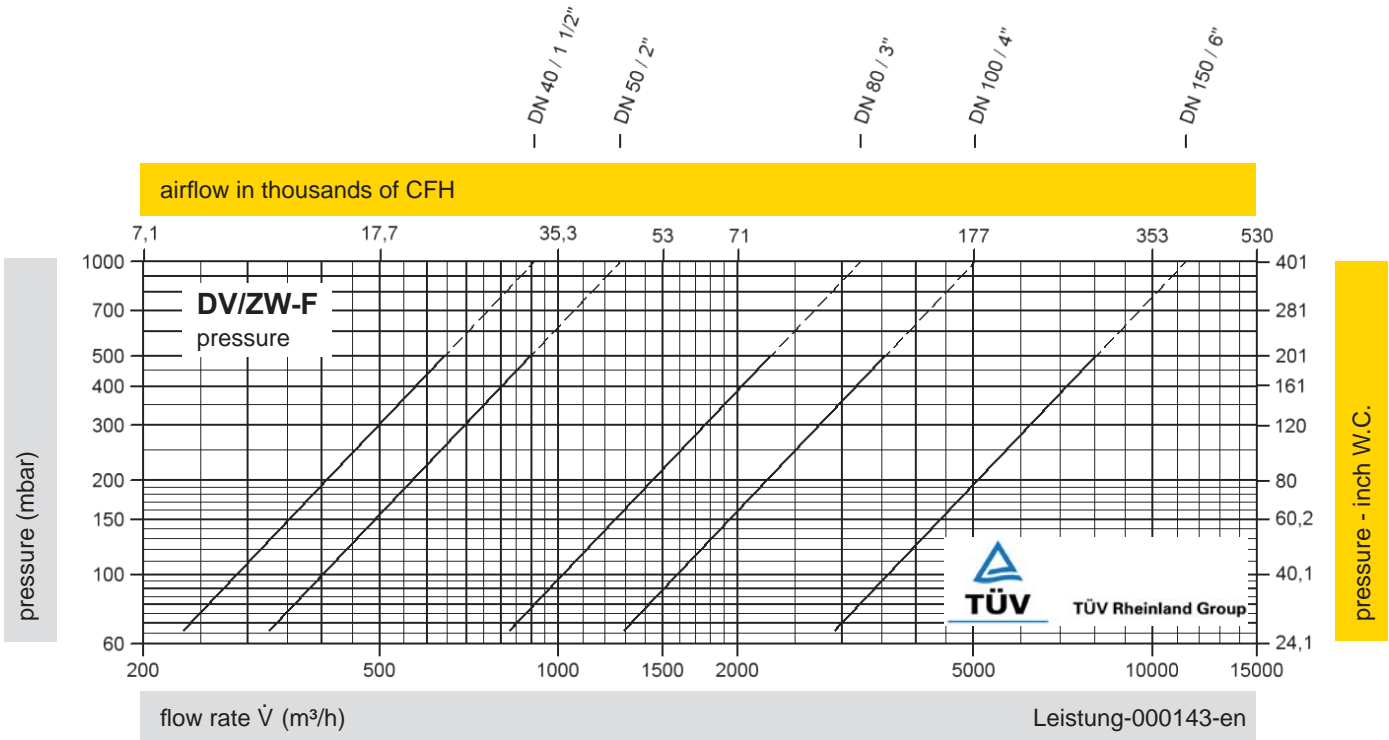

The flow capacity charts have been determined with a calibrated and TÜV certified flow capacity test rig. Volume flow \dot{V} in (m³/h) and CFH refer to the standard reference conditions of air ISO 6358 (20°C, 1bar). Conversion to other densities and temperatures refer to Vol. 1: "Technical Fundamentals".

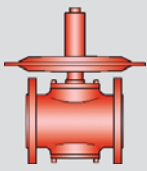

Blanketing Valve

low pressure reducing valve

ZM-R

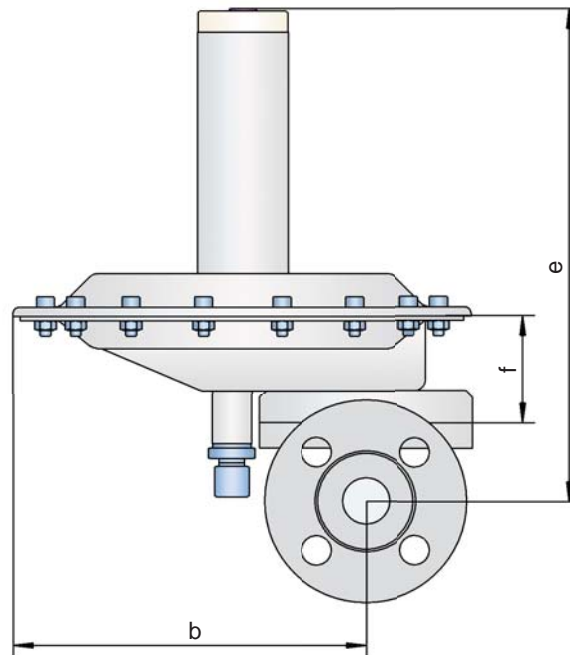
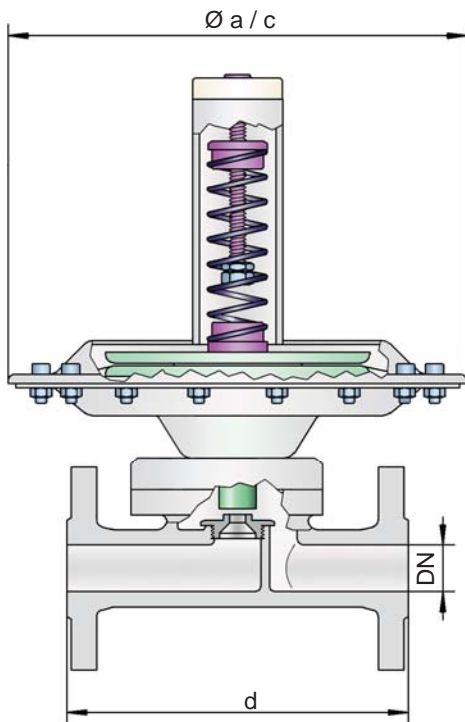

Pressure range:

Supply pressure:
up to +16 bar /
+6424 inch W.C.

Set pressure for
overpressure function:
up to +500 mbar /
+200 inch W.C.

Set pressure for
vacuum function:
up to -200 mbar /
-80 inch W.C.

Function and Description

The blanketing valve type ZM-R is a highly developed low pressure reducing valve. This valve is typically used to inert or blanket tanks, vessels or other process systems with nitrogen or other blanketing gases by controlling the tank pressure to its desired value. High nitrogen or blanketing gas supply pressures up to 16 bar / 232 psi are safely reduced down to only a few mbar / inch W.C..

The ZM-R low pressure reducing valve is a direct acting one stage pressure control device. It is designed as a membrane controlled, spring loaded proportional acting valve. The valve controls the tank pressure by increasing flow as the tank pressure drops. This means that the mass flow through the device depends on the pressure differential of the set pressure to the actual tank pressure. When the actual tank pressure reaches the set pressure the control unit closes and there is no flow.

At the control membrane (which can be made from PTFE or Viton) the tank pressure (P_2) is balanced with the adjustment spring and the supply pressure (P_1).

In a depressurized tank the adjustment spring holds the valve pallet in the fully open position. As the tank pressure increases the valve pallet moves toward the seat and the mass flow is reduced. When the desired tank pressure is reached the device will close.

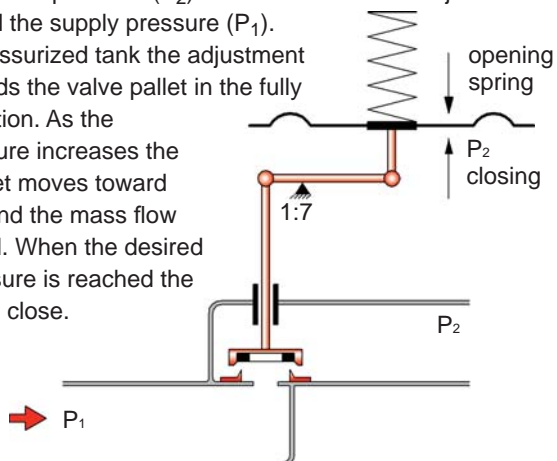

Should the tank pressure decrease the valve will open. If the plant is operated in a vacuum mode pressures down to -200 mbar / -80 inch W.C. relative pressure can be accommodated.

Special features and advantages

- one stage pressure reduction within a relatively high pressure range
- large membrane surface to increase the closing force
- all functional and wetted parts are made of stainless steel (or hastelloy if required)
- easy adjustment of set pressure (within the pressure range of the specific spring)
- vertical or horizontal installation (set pressure has to be adjusted for horizontal installation)
- no external energy supply required
- optimized flow performance, which reduces capital cost to a minimum as smaller sized vents are needed
- the valve pallet is guided within the housing to protect against harsh weather conditions, e.g. preventing freezing of pallet in cold weather conditions
- reducing within the vacuum range is possible
- high accuracy
- can be installed in explosion hazardous areas
- housing designed to 16 bar / 150 psi
- maintenance friendly design

Design and Specification

Two different designs are available:

Blanketing valve for overpressure, standard design **ZM-R**

Blanketing valve for vacuum, standard design **ZM-R** /

Other special devices can be supplied on request

For in-line valves any back pressure, which will influence the set pressure and opening characteristics, has to be taken into account.

Table 1: Dimensions		Dimensions in mm				Dimensions in inches			
To select the nominal size (DN), please use the flow rates on the following pages									
DN	15 / ½"	25 / 1"	50 / 2"	100 / 4"	15 / ½"	25 / 1"	50 / 2"	100 / 4"	
a	214	214	–	–	8.43	8.43	–	–	
b	168	168	–	–	6.61	6.61	–	–	
c*	–	–	214 / 360	360 / 600	–	–	8.43 / 14.17	14.17 / 23.62	
d	EN	150	160	150	250 / 250	5.91	6.3	5.91	9.84 / 9.84
	ASME	180	160	150	250 / 250	7.09	6.3	5.91	9.84 / 9.84
e	214	214	230	275 / 310	8.43	8.43	9.06	10.83 / 12.2	
f	87	87	103	148 / 155	3.43	3.43	4.06	5.83 / 6.10	

* depends upon size of diaphragm

Table 2: Material selection for housing				
Design	S	H	Optional: Inner part of housing electropolished Special materials upon request	
Housing	Stainless Steel	Hastelloy		
Valve seat	Stainless Steel	Hastelloy		
Valve pallet	Stainless Steel	Hastelloy		
Valve seat sealing	FFKM	FFKM		
Gasket	PTFE	PTFE		
Diaphragm P	PTFE	PTFE		Marking P
Alternative: Diaphragm V	Viton	-		Marking V

Table 3: Selection for valve seat (depending on flow rate)			
Size	Seat in mm / inches	Kvs	Number
25 / 1"	2,0 / 0.08	0,15	20
	4,5 / 0.18	0,60	45
	7,5 / 0.30	1,20	75
	10,0 / 0.39	1,70	100
	14,0 / 0.55	2,40	140
50 / 2"	14,0 / 0.55	3,00	140
	18,0 / 0.71	7,00	180
	26,0 / 1.02	15,00	260
100 / 4"	42,0 / 1.65	35,00	420
	55,0 / 2.17	70,00	550

* 1 Kvs = 0.86 Cv; 1 Cv = 1.17 Kvs



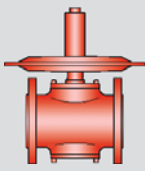

In-Line Pressure Reducing Valve

low pressure reducing valve

ZM-R

Table 4: Connection type

FD	EN 1092-1; Form B1	EN	other types upon request
FA	ASME B16.5; 150 lbs RFSF	ASME	
G	Thread	G or NPT	

Flow rates for P2 pressure range (Europe – metric units)

ZM-R 15 / ZM-R 25: flow rate (air, 0°C) at $\square P = P1 - P2$ and valve full open											
overpressure P1 (bar) P2 (mbar)	0,15	0,25	0,40	0,65	1,00	1,50	2,50	4,00	6,00	10,00	Seat-Ø
	[Nm ³ /h]	[Nm ³ /h]	[Nm ³ /h]	[Nm ³ /h]	[Nm ³ /h]	[Nm ³ /h]	[Nm ³ /h]	[Nm ³ /h]	[Nm ³ /h]	[Nm ³ /h]	[mm]
10	6,2 12,4 17,5 24,8	8,1 16,2 23,0 32,5	10,3 20,7 29,3 41,4	13,2 26,5 37,6 53,1	16,5 33,0 46,7 66,0	20,6 41,2 58,4 82,4	28,8 57,6 81,6 115,2	41,1 82,2 116,5 164,5	57,5 115,0 163,0 230,1	90,3 180,7 256,0 361,4	Ø 4,5 Ø 7,5 Ø 10,0 Ø 14,0
20	6,0 12,0 17,0 24,0	7,9 15,9 22,6 31,9	10,2 20,5 29,1 41,1	13,2 26,4 37,5 52,9	16,5 33,0 46,7 66,0	20,6 41,2 58,4 82,4	28,8 57,6 81,6 115,2	41,1 82,2 116,5 164,5	57,5 115,0 163,0 230,1	90,3 180,7 256,0 361,4	Ø 4,5 Ø 7,5 Ø 10,0 Ø 14,0
100	3,8 7,7 10,9 15,4	6,7 13,4 18,9 26,8	9,4 18,9 26,8 37,9	12,8 25,6 36,3 51,3	16,4 32,8 46,5 65,6	20,6 41,2 58,4 82,4	28,8 57,6 81,6 115,2	41,1 82,2 116,5 164,5	57,5 115,0 163,0 230,1	90,3 180,7 256,0 361,4	Ø 4,5 Ø 7,5 Ø 10,0 Ø 14,0
200	- - - -	4,0 8,0 11,4 16,1	8,0 16,1 22,9 32,3	12,1 24,2 34,3 48,4	16,1 32,3 45,8 64,6	20,6 41,2 58,4 82,4	28,8 57,6 81,6 115,2	41,1 82,2 116,5 164,5	57,5 115,0 163,0 230,1	90,3 180,7 256,0 361,4	Ø 4,5 Ø 7,5 Ø 10,0 Ø 14,0
500	- - - -	- - - -	- - - -	7,8 15,6 22,1 31,2	14,2 28,5 40,4 57,0	20,1 40,3 57,1 80,7	28,8 57,6 81,6 115,2	41,1 82,2 116,5 164,5	57,5 115,0 163,0 230,1	90,3 180,7 256,0 361,4	Ø 4,5 Ø 7,5 Ø 10,0 Ø 14,0

ZM-R 50: flow rate (air, 0°C) at $\Delta P = P1 - P2$ and valve full open											
overpressure P1 (bar) P2 (mbar)	0,15	0,25	0,40	0,65	1,00	1,50	2,50	4,00	6,00	10,00	Seat-Ø
	[Nm ³ /h]	[Nm ³ /h]	[Nm ³ /h]	[Nm ³ /h]	[Nm ³ /h]	[Nm ³ /h]	[Nm ³ /h]	[Nm ³ /h]	[Nm ³ /h]	[Nm ³ /h]	[mm]
10	28,9 70,3 150,0	37,9 92,1 196,5	48,3 117,4 250,4	61,9 150,4 320,8	77,0 187,1 399,1	96,2 233,6 498,3	134,5 326,6 696,5	191,9 466,1 994,0	268,5 652,1 1390	421,6 1024 2183	Ø 14,0 Ø 18,0 Ø 26,0
20	28,0 68,1 145,3	37,3 90,6 193,3	47,9 116,5 248,4	61,7 150,0 319,9	77,0 187,1 399,0	96,2 233,6 498,3	134,5 326,6 696,5	191,9 466,1 994,0	268,5 652,1 1390	421,6 1024 2183	Ø 14,0 Ø 18,0 Ø 26,0
100	18,0 43,8 93,5	31,2 75,9 162,0	44,2 107,4 229,1	59,9 145,5 310,2	76,6 186,1 396,9	96,2 233,6 498,3	134,5 326,6 696,5	191,9 466,1 994,0	268,5 652,1 1390	421,6 1024 2183	Ø 14,0 Ø 18,0 Ø 26,0
200	- - -	18,8 45,8 97,6	37,7 91,6 195,3	56,5 137,4 293,0	75,4 183,2 390,6	96,2 233,6 498,3	134,5 326,6 696,5	191,9 466,1 994,0	268,5 652,1 1390	421,6 1024 2183	Ø 14,0 Ø 18,0 Ø 26,0
500	- - -	- - -	- - -	36,4 88,6 188,9	66,6 161,7 344,9	94,1 228,7 487,8	134,5 326,6 696,5	191,9 466,1 994,0	268,5 652,1 1390	421,6 1024 2183	Ø 14,0 Ø 18,0 Ø 26,0

ZM-R 100: flow rate (air, 0°C) at $\Delta P = P1 - P2$ and valve full open											
overpressure P1 (bar) P2 (mbar)	0,15	0,25	0,40	0,65	1,00	1,50	2,50	4,00	6,00	10,00	Seat-Ø
	[Nm ³ /h]	[Nm ³ /h]	[Nm ³ /h]	[Nm ³ /h]	[Nm ³ /h]	[Nm ³ /h]	[Nm ³ /h]	[Nm ³ /h]	[Nm ³ /h]	[Nm ³ /h]	[mm]
10	346 703	453 921	587 1174	741 1504	922 1871	1151 2336	1609 3266	2296 4661	3212 6512	5045 10241	Ø 42,0 Ø 55,0
20	335 681	446 906	574 1165	739 1500	921 1871	1151 2336	1609 3266	2296 4661	3212 6512	5045 10241	Ø 42,0 Ø 55,0
100	216 438	374 759	529 1074	716 1455	917 1861	1151 2336	1609 3266	2296 4661	3212 6512	5045 10241	Ø 42,0 Ø 55,0
200	- -	225 458	451 916	676 1374	902 1832	1151 2336	1609 3266	2296 4661	3212 6512	5045 10241	Ø 42,0 Ø 55,0
500	- -	- -	- -	436 886	796 1617	1127 2287	1609 3266	2296 4661	3212 6512	5045 10241	Ø 42,0 Ø 55,0

Flow rates for P2 vacuum range (Type ZM-R/N) upon request



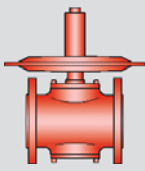

In-Line Pressure Reducing Valve

Flow rates for P2 pressure range (english/american units – non-metric)

ZM-R

ZM-R 15 / ZM-R 25: flow rate (air, 32°F) at □P = P1 - P2 and valve full open											
overpressure P1 (psi) P2 ("wc)	2.18	3.63	5.80	9.43	14.50	21.76	36.26	58.02	87.02	145.04	Seat-Ø
	[SCFH]	[SCFH]	[SCFH]	[SCFH]	[SCFH]	[SCFH]	[SCFH]	[SCFH]	[SCFH]	[SCFH]	[inch]
3.94	219	287	366	469	583	728	1018	1453	2032	3191	Ø 0.18
	439	574	732	938	1166	1456	2036	2905	4064	6382	Ø 0.29
	621	814	1037	1329	1652	2063	2884	4116	5758	9042	Ø 0.39
	877	1149	1464	1876	2333	2913	4072	5810	8128	12764	Ø 0.55
7.87	212	282	363	468	583	728	1018	1453	2032	3191	Ø 0.18
	425	565	726	935	1166	1456	2036	2905	4064	6382	Ø 0.29
	602	800	1029	1325	1652	2063	2884	4116	5758	9042	Ø 0.39
	849	1130	1452	1870	2333	2913	4072	5810	8128	12764	Ø 0.55
39.4	137	237	335	453	580	728	1018	1453	2032	3191	Ø 0.18
	273	474	670	907	1166	1456	2036	2905	4064	6382	Ø 0.29
	387	671	949	1285	1643	2063	2884	4116	5758	9042	Ø 0.39
	547	947	1339	1814	2320	2913	4072	5810	8128	12764	Ø 0.55
78.7	-	143	285	428	571	728	1018	1453	2032	3191	Ø 0.18
	-	285	571	856	1142	1456	2036	2905	4064	6382	Ø 0.29
	-	404	809	1213	1617	2063	2884	4116	5758	9042	Ø 0.39
	-	571	1142	1713	2284	2913	4072	5810	8128	12764	Ø 0.55
196.9	-	-	-	276	504	713	1018	1453	2032	3191	Ø 0.18
	-	-	-	552	1108	1426	2036	2905	4064	6382	Ø 0.29
	-	-	-	782	1428	2020	2884	4116	5758	9042	Ø 0.39
	-	-	-	1104	2016	2851	4072	5810	8128	12764	Ø 0.55

ZM-R 50: flow rate (air, 32°F) at □P = P1 - P2 and valve full open											
overpressure P1 (psi) P2 ("wc)	2.18	3.63	5.80	9.43	14.50	21.76	36.26	58.02	87.02	145.04	Seat-Ø
	[SCFH]	[SCFH]	[SCFH]	[SCFH]	[SCFH]	[SCFH]	[SCFH]	[SCFH]	[SCFH]	[SCFH]	[inch]
3.94	1023	1340	1708	2188	2722	3398	4750	6779	9483	14892	Ø 0.55
	2486	3254	4149	5314	6610	8253	11536	16462	23030	36166	Ø 0.71
	5300	6939	8846	11332	14094	17597	24600	35104	49109	77119	Ø 1.02
7.87	991	1318	1694	2182	2721	3398	4750	6779	9483	14892	Ø 0.55
	2407	3201	4115	5298	6608	8253	11536	16462	23030	36166	Ø 0.71
	5132	6827	8775	11298	14091	17597	24600	35104	49109	77119	Ø 1.02
39.4	638	1105	1563	2116	2707	3398	4750	6779	9483	14892	Ø 0.55
	1549	2684	3795	5139	6573	8253	11536	16462	23030	36166	Ø 0.71
	3304	5722	8093	10958	14017	17597	24600	35104	49109	77119	Ø 1.02
78.7	-	666	1332	1998	2664	3398	4750	6779	9483	14892	Ø 0.55
	-	1617	3235	4852	6470	8253	11536	16462	23030	36166	Ø 0.71
	-	3449	6898	10347	13796	17597	24600	35104	49109	77119	Ø 1.02
196.9	-	-	-	1288	2352	3327	4750	6779	9483	14892	Ø 0.55
	-	-	-	3129	5713	8079	11536	16462	23030	36166	Ø 0.71
	-	-	-	6672	12181	17227	24600	35104	49109	77119	Ø 1.02

ZM-R 100: flow rate (air, 32°F) at $\Delta P = P1 - P2$ and valve full open											
overpressure P1 (psi) P2 ("wc)	2.18	3.63	5.80	9.43	14.50	21.76	36.26	58.02	87.02	145.04	Seat-Ø
	[SCFH]	[SCFH]	[SCFH]	[SCFH]	[SCFH]	[SCFH]	[SCFH]	[SCFH]	[SCFH]	[SCFH]	[inch]
3.94	12245 24856	16033 32544	20438 41485	26181 53144	32562 66097	40656 82525	56834 115365	81101 164624	113458 230303	178171 361660	Ø 1.65 Ø 2.17
7.87	11857 24068	15772 32014	20272 41150	26102 52984	32555 66082	40656 82525	56834 115365	81101 164624	113458 230303	178171 361660	Ø 1.65 Ø 2.17
39.4	7633 15494	13221 26836	18697 37952	25316 51387	32384 65735	40656 82525	56834 115365	81101 164624	113458 230303	178171 361660	Ø 1.65 Ø 2.17
78.7	- -	7968 16175	15937 32350	23905 48525	31874 64699	40656 82525	56834 115365	81101 164624	113458 230303	178171 361660	Ø 1.65 Ø 2.17
196.9	- -	- -	- -	15414 31289	28142 57125	39800 80788	56834 115365	81101 164624	113458 230303	178171 361660	Ø 1.65 Ø 2.17

Flow rates for P2 vacuum range (Type ZM-R/N) upon request



www.protego.com



for safety and environment

PROTEGO® Pressure/Vacuum Relief Valves with Flame Arrester - end-of-line



Volume 7

Volume 7



for safety and environment

The working principle and location of the installation of valves on tanks and apparatus is discussed in „Technical Fundamentals“ (Vol. 1). In this chapter we present end-of-line pressure/vacuum relief valves with integrated flame arrester units.

Function and Description

These valves are used to protect process units and equipment (e.g. tanks, pipelines) from exceeding maximum allowable operating pressures and vacuum. In addition these devices protect against atmospheric deflagration. Some of the devices are also designed to protect against endurance burning (Figure 1).

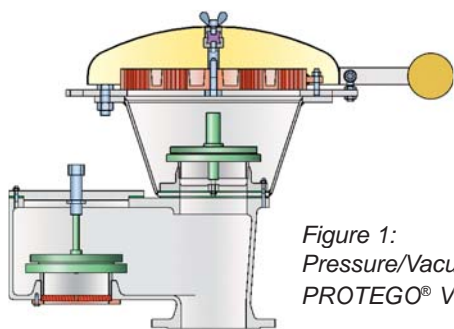

Figure 1:
Pressure/Vacuum Relief Valve
PROTEGO® VD/SV-HRL

PROTEGO® Pressure Relief Valves with an integrated flame arrester unit provide protection against unacceptable overpressure, atmospheric deflagration and endurance burning. In addition the devices reduce emissions almost up to the set pressure.

PROTEGO® Vacuum Relief Valves with an integrated flame arrester unit provide protection against unacceptable vacuum and atmospheric deflagration. In addition they avoid air intake almost up to the set pressure.

PROTEGO® Pressure Vacuum Relief Valves with an integrated flame arrester unit fulfil all the above mentioned functions for pressure and vacuum relief and protect against atmospheric deflagration or against atmospheric deflagration and endurance burning.

The special design of the PROTEGO® valves achieves full lift after 10% overpressure above the set pressure. This “full-lift-type-technology” allows for the use of set pressures just 10% below the maximum allowable working pressure (MAWP or Design Pressure) of the Tank. After just 10% overpressure above set pressure the valve will reach its full capacity to safely relieve the required mass flow. Conventional relief valves for low pressure applications need 80%-100% overpressure (API 2000) for reaching full lift and full relieving capacity. They open later and shut off earlier, which results in unnecessary product losses.

Special features and advantages

Specific investments into research and development allowed PROTEGO® to design a valve for low pressure applications providing you with the following advantages:

- 10% “full-lift-type-technology” reducing product losses (possible reduction of breathing losses greater than 30%)
- PROTEGO® valves open later and shut off earlier than conventional valves, which results in optimized pressure management and reduction of blanketing gas losses

- increased flow performance (result: smaller valves can be installed resulting in capital saving)
- lowest leak rates world wide for low pressure valves
- flame transmission proof for almost any chemical mixture
- valve pallet is guided within the housing to protect against harsh weather conditions
- flame arrester unit is not in contact with product vapour under normal operating conditions, which reduces maintenance intervals
- endurance burning protection against alcohols

To achieve the highest expectations of the industry for the lowest leak rates, our valve pallets and seats are manufactured from high quality stainless steel and are hand lapped in a special process. Air cushion membran technology is utilized for low set pressures.

Valves with integrated flame arrester units are available for substances from explosion groups IIA and IIB3 (NEC D and C) and special approvals are available for alcohols.

Main areas of application: as pressure and vacuum valves, as pressure relief valves, as pressure holding/conservation valves, as simple control valves for storage of flammable liquids

PROTEGO® Diaphragm Valves function as pressure vacuum relief valves. The flexible diaphragm allows them to work as a dynamic flame arrester, which provides endurance burning protection. For additional safety these devices are equipped with a static flame arrester unit. This “one-of-a-kind” diaphragm valve can be used under extreme cold weather conditions below freezing and for problem products, which e.g. tend to polymerize (Styrene, Acrylics). A specially designed valve seat combined with the flexible diaphragm prevents blocking of the valve through freezing product vapours at low temperatures. Ice bridges break and fall off through deformation of the diaphragm if pressure increases.

This device has no guiding elements which are likely to stick and keep the device closed.

Main areas of application: same as above in storage of flammable liquids and specifically for storage of monomers.

PROTEGO® High Velocity Pressure Relief Valves (Jet Valves) open and close almost immediately at set point. This function is achieved by an integrated magnet. Through this the overpressure needed from set point to full lift is practically 0%, which clearly reduces emissions. All PROTEGO® high velocity relief valves are tested for oscillating flow and are equipped with a specially designed valve cone and seat, which produces a vertical upright free jet during pressure relief. This ensures an effective leaning of the discharged vapours and reduces the gas concentration to a minimum in direct proximity (e.g. boat deck) of the valve. The devices function on the working principal of a dynamic flame arrester and are approved for the vapour groups IIA, IIB3 and IIC (NEC D, C and B).

Main areas of application: transport of flammable liquids on tank ships and special on shore applications.

Installation and servicing

All PROTEGO® devices are delivered with detailed installation and maintenance manuals. Please pay special attention to the warnings on how to remove transport protection if this has been installed in the device to prevent damage during transport. Specially developed check lists are available to ensure correct installation and operation of the device.

Selection and sizing

For a safe operation and protection of a plant, the selection and sizing of the correct PROTEGO® device is necessary. The following criteria have to be considered for pre-selection:

Function: Pressure relief, vacuum relief or combined pressure/vacuum relief, protection against atmospheric deflagration, or atmospheric deflagration and endurance burning.

Type of Valve: Weight loaded valve, diaphragm valve, high velocity pressure relief valve or high velocity pressure relief valve with combined vacuum valve.

Design: with horizontal or vertical connection to the protected vessel. These valves are weight loaded, so the pallet has to be installed in an horizontal orientation. The maximum achievable pressure setting will depend on the design of the valve. Metallic sealing or soft sealing are important criteria for low leak rates and have to be chosen based on the intended use.

Explosion group: IIA, IIB3, IIC (NEC D, C, B).

Process of combustion: endurance burning or atmospheric deflagration

Operating conditions: Polymerization, condensation, problems which lead to clogging of the FLAMEFILTER®, operating temperature, operating pressure, oxygen concentration, volume flow.

The **valve size** has to be determined so that the volume flow which has to be discharged does not lead to an increase of internal pressure above the maximum allowable working pressure of the vessel to be protected. For sizing the valves certified pressure/volume flow diagrams are provided. The operating conditions have to be known for correct sizing. Sometimes vessels are already equipped with pre-existing nozzles (e.g. old vessels). In such cases the volume flow may have to be discharge over several valves. For correct sizing superimposed and built-up backpressure must be considered.

Valve sizing:

The valve is sized dependent on the required volume flow, which is calculated (→ Chapter 1), or given.

Given: Volume flow (e.g. in- or outbreathing of a storage tank as sum of the pump rates and thermal breathing) \dot{V}_{max} in m³/h (CFH) and maximum allowable (tank-) pressure p in mbar (inch W.C.).

Desired: Nominal valve size DN

Procedure: The required size of the valve can be taken from the intersection point of \dot{V}_{max} and p valve operating pressure = max. allowable tank pressure. The pressure diagram shows the valves flow performance in relation to the opening pressure and is determined at the full lift position of the pallet.

The set pressure of the valve has to be determined such that the required volume flow can be discharged safely. A valve with 10% overpressure characteristic has to be set 10% below the maximum allowable tank pressure.

Many conventional valves require 100% overpressure to reach full lift. For these valves the set pressure will be 50% below of the maximum allowable tank pressure. These valves open earlier and shut off later allowing avoidable product losses.

Alternatively the valve performance may have to be checked if the required size and maximum allowable tank pressure are provided.

Given: (Tank-) nozzle size DN and maximum allowable (tank-) pressure p in mbar (inch W.C.)

Desired: flow rate of valve in m³/h (CFH) and set pressure p_{set}

Procedure: The intersection point of the straight line through p and the valve performance curve of the (nozzle-) size DN determine the flow rate \dot{V}_{max} . The set pressure p_{set} will be 10% (PROTEGO® - Technology), 40% or 100% below the maximum allowable (tank-) pressure p_T .

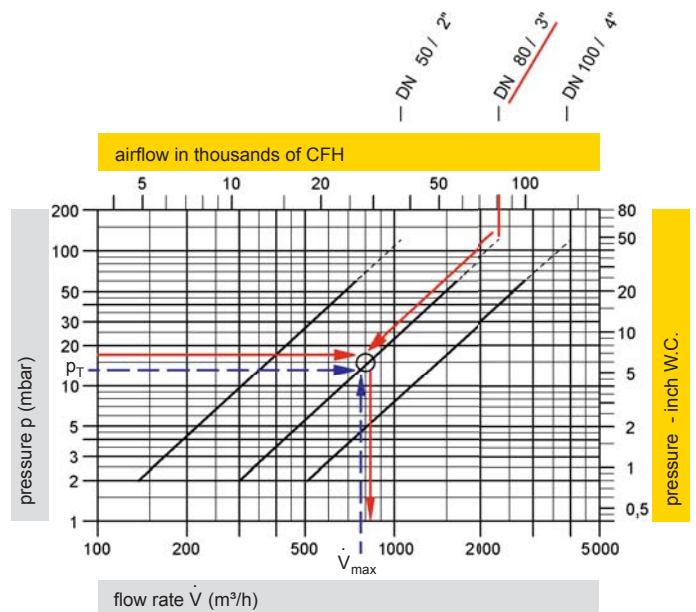

The set pressure of the valve (= valve starts to open) the maximum allowable pressure of the equipment minus the valves characteristic overpressure which is required for the valve to reach full lift.

The overpressure percentage of PROTEGO® valves is 10% (unless supplied otherwise). Within 10% overpressure the device will reach its performance at full lift. A further increase in flow performance will follow the curve in the pressure volume flow diagram.















For choosing the correct material the plant and engineering specifications have to be considered.



PROTEGO® Pressure/Vacuum Relief Valves with Flame Arrester – end-of-line

Catalogue

Type	Size	Pressure setting		= endurance burning proof = prevent flashback in case of atmospheric deflagrations O / X	Explosion group		Approvals	Design O = horizontal connection X = vertical connection	O = soft sealing X = metallic sealing	O = for critical medium (polymerisation, corrosion, crystallisation)	O = Heating jacket, heating coil	Page	
		positive setting range mbar / inch W.C.	negative setting range mbar / inch W.C.		ATEX	NEC							
Pressure Relief Valves, Pallet Type													
	P/EB	50 - 80 2" - 3"	+3.5 up to +210/ +1.4 up to +84	O / X	IIA	D	ATEX	X	O / X		O	290 - 292	
	P/EB-E	50 - 80 2" - 3"	+3.5 up to +210/ +1.4 up to +84	O / X	IIB1	-	ATEX	X	O / X		O	294 - 296	
	P/EBR	80 - 100 3" - 4"	+3.5 up to +210/ +1.4 up to +84	O / X	IIA, IIB3	D, C	ATEX	X	O / X		O	298 - 300	
	P/EBR-E	80 - 100 3" - 4"	+3.5 up to +210/ +1.4 up to +84	O / X	IIB1	-	ATEX	X	O / X		O	302 - 304	
	D-SVL-EB	150 -200 6" - 8"	+2.0 up to +60/ +0.8 up to +24	O / X	IIA	D	ATEX	X	O / X		O	306 - 308	
	BE/HR-D	150 -200 6" - 8"	+2.0 up to +35/ +0.8 up to +14	O / X	IIA	D	ATEX	X	O / X			310 - 312	
Vacuum Relief Valves, Pallet Type													
	SV/E	50 - 300 2" - 12"		-2.0 up to -60/ -0.8 up to -24	X	IIB3, IIB IIC	C, B, B	ATEX IMO	O	O / X		O	314 - 317
Pressure/Vacuum Relief Valves, Pallet Type													
	PV/EB	50 - 80 2" - 3"	+2.0 up to +210/ +0.8 up to +84	-3.5 up to -35/ -1.4 up to -14	O / X	IIA	D	ATEX	O	O / X		O	318 - 320
	PV/EB-E	50 - 80 2" - 3"	+2.0 up to +210/ +0.8 up to +84	-3.5 up to -35/ -1.4 up to -14	O / X	IIB1	-	ATEX	O	O / X		O	322 - 324
	PV/EBR	80 - 100 3" - 4"	+2.0 up to +210/ +0.8 up to +84	-3.5 up to -50/ -1.4 up to -20	O / X	IIA, IIB3	D	ATEX	O	O / X		O	326 - 329
	PV/EBR-E	80 - 100 3" - 4"	+2.0 up to +210/ +0.8 up to +84	-3.5 up to -50/ -1.4 up to -20	O / X	IIB1	-	ATEX	O	O / X		O	330 - 332

Type	Size	Pressure setting		O = endurance burning proof X = prevent flashback in case of atmospheric deflagrations	Explosion group		Approvals	Design O = horizontal connection X = vertical connection	O = soft sealing X = metallic sealing	O = for critical medium (polymerisation, corrosion, crystallisation)	O = Heating jacket, heating coil	Page
		positive setting range mbar / inch W.C.	negative setting range mbar / inch W.C.		ATEX	NEC						
Pressure/Vacuum Relief Valves, Pallet Type (Continuation)												
 VD/SV-AD and VD/SV-ADL	80 - 150 3" - 6"	+3.5 up to +35/ +1.4 up to +14	-2.0 up to -35/ -0.8 up to -14	X	IIB3	C	ATEX	X	O/X			334 - 336
 VD/SV-HR	80 - 100 3" - 4"	+3.5 up to +35/ +1.4 up to +14	-2.0 up to -35/ -0.8 up to -14	O/X	IIA, IIB3	D, C	ATEX	X	O/X			338 - 341
 VD/SV-HRL	100-150 4" - 6"	+3.5 up to +35/ +1.4 up to +14	-2.0 up to -35/ -0.8 up to -14	O/X	IIA	D	ATEX	X	O/X			342 - 344
 VD-SV-EB	200 10"	+2.0 up to +60/ +0.8 up to +24	-2.0 up to -60/ -0.8 up to -24	O/X	IIA	D	ATEX	X	O/X		O	346 - 348
 VD/TS	50 - 300 2" - 12"	+3.5 up to +50/ +1.4 up to +20	-2.0 up to -25/ -0.8 up to -10	X	IIB3	C	ATEX	X	O/X			350 - 353
Pressure/Vacuum Relief Valves, Diaphragm Valves												
 UB/SF	80 - 150 3" - 6"	+3.5 up to +140/ +1.4 up to +56	-3.5 up to -35/ -1.4 up to -16	O/X	IIB3	C	ATEX	X	O	O	O	354 - 361
 UB/DF	80 - 150 3" - 6"	+3.5 up to +140/ +1.4 up to +56		O/X	IIB3	C	ATEX	X	O	O	O	362 - 367
 UB/VF	80 - 150 3" - 6"		-3.5 up to -35/ -1.4 up to -16	X	IIB3	C	ATEX	X	O	O	O	368 - 371
Pressure Relief Valves, High Velocity Valve												
 DE/S	80 - 150 3" - 6"	+100 up to +500/ +40 up to +200		O/X	IIB3, IIB	C, B	ATEX	X	X			 -IIB  -IIB3
 DE/S-MK VI	80 - 150 3" - 6"	+60 up to +350/ +24 up to +140		O/X	IIB3, IIC	C, B	ATEX IMO	X	X			 -IIB3  -IIC



for safety and environment

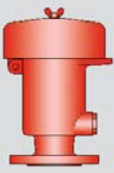

Pressure Relief Valve

deflagration- and endurance burning-proof



PROTEGO® P/EB

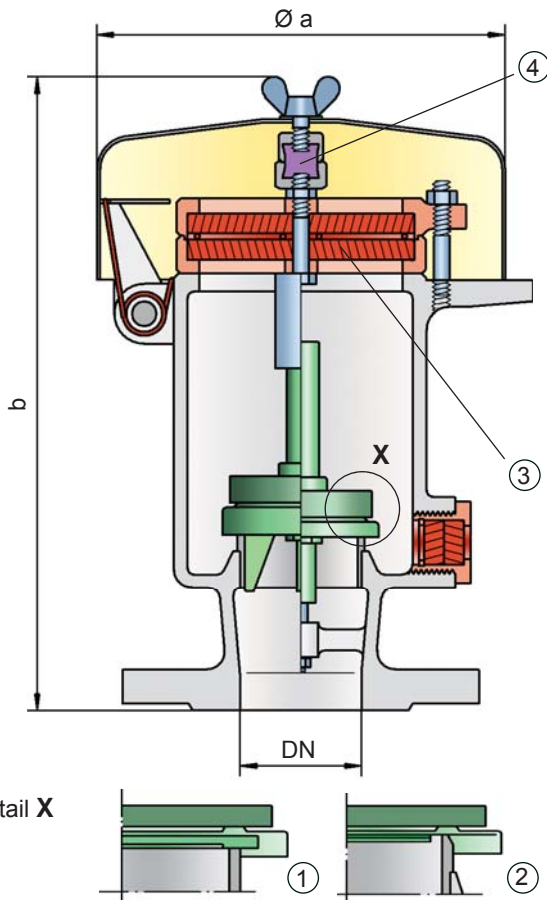

sured by the valve seats made of high quality stainless steel and with individually lapped valve pallets (1) or with an air cushion seal (2) in conjunction with a high quality FEP diaphragm. The valve pallets are also available with a PTFE seal to prevent the valve pallets from sticking when sticky products are used and to enable the use in corrosive fluids. After the excess pressure is discharged, the valve reseats and provides a tight seal.

If the set pressure is exceeded, explosive gas/product-vapour air mixtures are released to the atmosphere. If this mixture ignites, the integrated PROTEGO® flame arrester unit (3) prevents flame transmission into the tank. If additional mixture continues to flow and stabilized burning occurs, the integrated flame arrester unit prevents flashback as a result from endurance burning. The valve is protected and also fulfils its function under this severe service conditions. The spring loaded weather hood opens as soon as the fusible element (4) melts.

The valve can be used up to an operating temperature of +60°C / 140°F and meets the requirements of European tank design standard EN 14015 – Appendix L and ISO 28300 (API 2000).

Type-approved in accordance with the current ATEX Directive and EN 12874 as well as other international standards.

Special Features and Advantages

- requires only 10% overpressure to full lift
- through 10% technology higher set pressures can be used which results in product loss reduction compared to conventional 40% and 100% overpressure technology vents (compare API 2000)
- more design flexibility through higher reseating pressures; vents reseal when conventional vent is still discharging costly product or nitrogen
- high performance seal reducing product loss below EPA's 500ppm rule preventing environmental pollution
- the valve disc is guided within the housing to protect against harsh weather conditions
- can be used as protective system according ATEX in areas subject to explosion hazards
- PROTEGO® flame arrester unit provides protection against atmospheric deflagration and endurance burning
- flame arrester unit integrated into the valve saves space, weight and reduces cost
- flame arrester unit protected from clogging through product vapour
- flame arrester unit has a low pressure drop
- flame transmission proof condensate drain
- maintenance friendly design
- modular design enables individual FLAMEFILTER® and valve pallet to be replaced

Pressure settings:

+3.5 mbar up to +210 mbar
 +1.4 inch W.C. up to +84 inch W.C.
 Higher pressure settings upon request.

Function and Description

The deflagration-proof and endurance burning-proof P/EB type PROTEGO® valve is a highly developed pressure relief valve with an integrated flame arrester unit. It is primarily used as a safety device for flame transmission proof outbreathing on tanks, containers and process engineering apparatus. The valve offers reliable protection against excess pressure and prevents product losses almost up to the set pressure; it also protects against atmospheric deflagration as well as endurance burning if stabilized burning occurs. The PROTEGO® flame arrester unit is designed to achieve minimum pressure drop with maximum safety. The P/EB valve is available for substances of explosion group IIA (NEC group D MESH > 0.90 mm).

When the set pressure is reached, the valve starts to open and reaches full lift within 10% overpressure. This unique 10% technology enables a set pressure that is only 10% below the maximum allowable working pressure (MAWP) of the tank. After years of development, this typical opening characteristic of a safety relief valve is now also available for the low pressure range.

The tank pressure is maintained up to the set pressure with a tightness that is far superior to the conventional standard due to our state of the art manufacturing technology. This feature is en-



Vents - 10% Technology
(Flyer pdf)



Leak Rate/10% Technology
(Flyer pdf)



Demonstration of endurance burning
Video

Design Types and Specifications

The valve disc is weight-loaded. At set pressure >80 mbar (32.1 inch W.C.), an elongated design is used

There are two different designs:

Pressure relief valve, basic design

P/EB -

Pressure relief valve with heating jacket

P/EB -

(max. heating fluid temperature +85°C / 185°F)

Additional special devices available upon request

Table 1: Dimensions

Dimensions in mm / inches

To select the nominal size (DN), please use the flow capacity chart on the following page

DN	50 / 2"	50 / 2"	80 / 3"	80 / 3"
Set pressure	≤ +80 mbar ≤ +32.1 inch W.C.	> +80 mbar > +32.1 inch W.C.	≤ +80 mbar ≤ +32.1 inch W.C.	> +80 mbar > +32.1 inch W.C.
a	218 / 8.58	218 / 8.58	218 / 8.58	218 / 8.58
b	287 / 11.30	452 / 17.80	289 / 11.38	454 / 17.87

Dimensions for Pressure Relief Valve with heating jacket upon request

Table 2: Selection of explosion group

MESG	Expl. Gr. (IEC/CEN)	Gas Group (NEC)	Special approvals upon request
> 0,90 mm	IIA	D	

Table 3: Material selection for housing

Design	B	C	Special materials upon request
Housing	Steel	Stainless Steel	
Heating jacket (P/EB-H-...)	Steel	Stainless Steel	
Valve seat	Stainless Steel	Stainless Steel	
Weather hood	Steel	Stainless Steel	

Table 4: Material combination of flame arrester unit

Design	A	Special materials upon request
FLAMEFILTER® cage	Stainless Steel	
FLAMEFILTER®	Stainless Steel	
Spacer	Stainless Steel	

Table 5: Material selection for valve pallet

Design	A	B	C	D	Special materials and higher pressure settings upon request
Pressure range (mbar)	+3.5 up to +5.0	>+5.0 up to +14	>+14 up to +210	>+14 up to +210	
(inch W.C.)	+1.4 up to +2.0	>+2.0 up to +5.6	>+5.6 up to +84	>+5.6 up to +84	
Valve pallet	Aluminium	Stainless Steel	Stainless Steel	Stainless Steel	
Sealing	FEP	FEP	Metal to Metal	PTFE	

Table 6: Flange connection type

EN 1092-1; Form B1	other types upon request
ASME B16.5; 150 lbs RFSF	



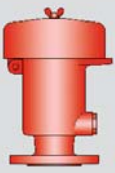

Pressure Relief Valve

Flow Capacity Chart

PROTEGO® P/EB

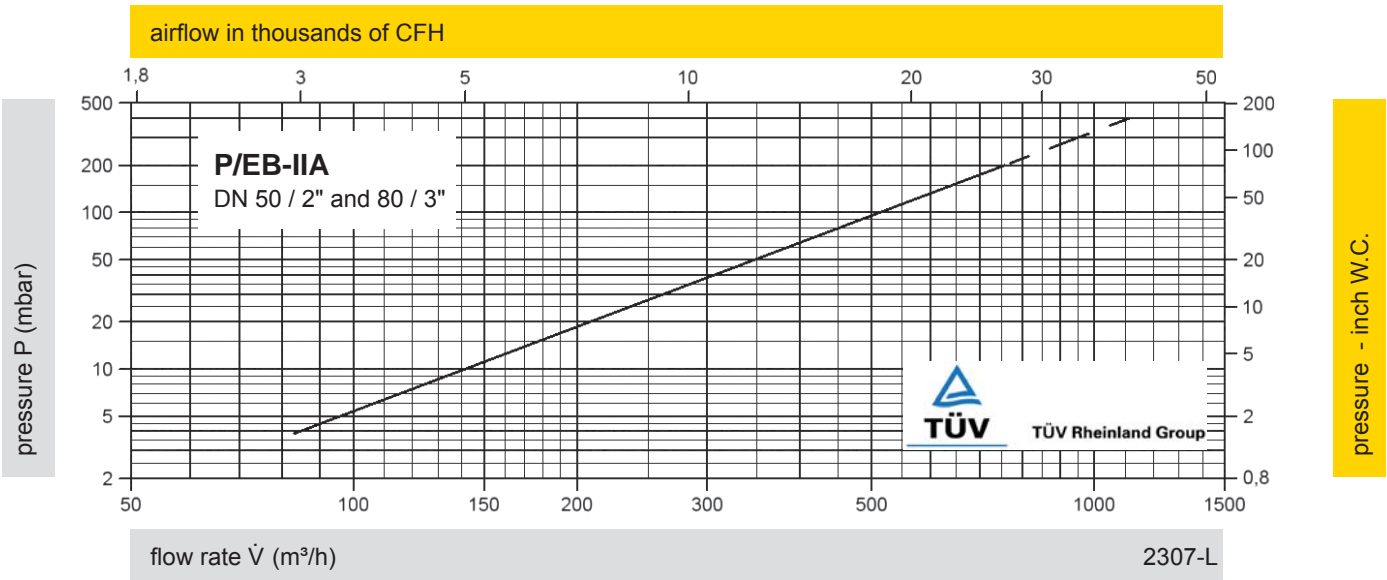

The flow capacity charts have been determined with a calibrated and TÜV certified flow capacity test rig. Volume flow \dot{V} in (m³/h) and CFH refer to the standard reference conditions of air ISO 6358 (20°C, 1bar). Conversion to other densities and temperatures refer to Vol. 1: "Technical Fundamentals".

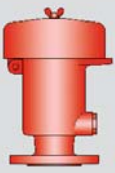

Pressure Relief Valve deflagration- and endurance burning-proof



PROTEGO® P/EB-E

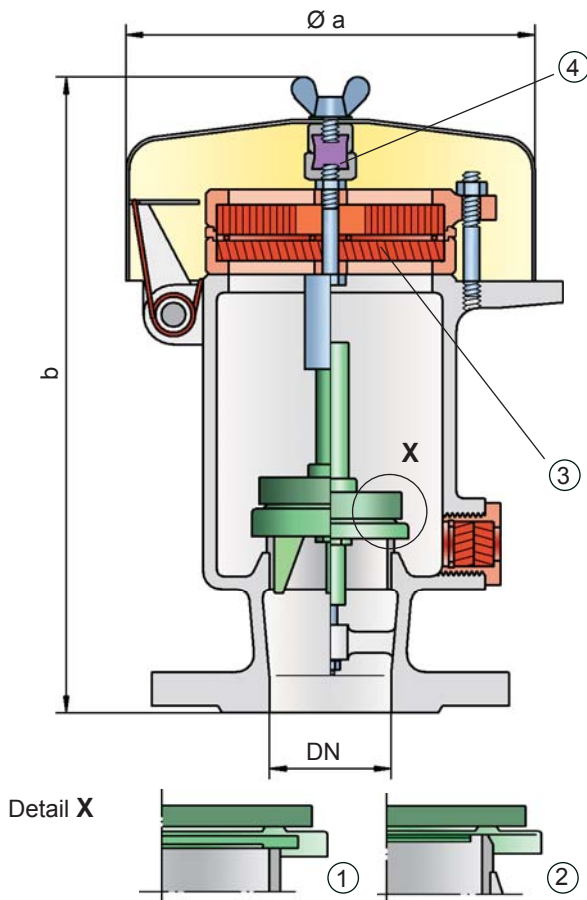

state of the art manufacturing. This feature is ensured by the valve seats made of high quality stainless steel and with individually lapped valve pallets (1) or with an air cushion seal (2) in conjunction with high quality FEP diaphragm. The valve pallets are also available with a PTFE seal to prevent the valve pallets from sticking when sticky products are used and to enable the use of corrosive fluids. After the excess pressure is discharged, the valve reseats and provides a tight seal.

If the set pressure is exceeded, explosive gas/product-vapour air mixtures are released to the atmosphere. If this mixture ignites, the integrated PROTEGO® flame arrester unit (3) prevents flame transmission into the tank. If additional mixture continues to flow and stabilized burning occurs, the integrated flame arrester unit prevents flashback as a result from endurance burning. The valve is protected and also fulfils its function under this severe service conditions. The spring loaded weather hood opens as soon as the fusible element (4) melts.

The valve can be used up to an operating temperature of +60°C / 140°F and meets the requirements of European tank design standard EN 14015 – Appendix L and ISO 28300 (API 2000).

Type-approved in accordance with the current ATEX Directive and EN ISO 16852 as well as other international standards.

Special Features and Advantages

- selecting set pressure close to relieving pressure results in product loss reduction
- more design flexibility through higher reseating pressures; vents reseal when conventional vent is still discharging costly product or nitrogen
- the valve disc is guided within the housing to protect against harsh weather conditions
- high performance seal reducing product loss below EPA's 500ppm rule preventing environmental pollution
- can be used as protective system according to ATEX in areas subject to explosion hazards
- safe against deflagration and endurance burning of alcohol/air mixtures from explosion group IIB1
- high flow capacity through large FLAMEFILTER® cross-section, results in low pressure drop
- PROTEGO® flame arrester unit provides protection against atmospheric deflagration and endurance burning
- flame arrester unit integrated into the valve saves space, weight and reduces cost
- FLAMEFILTER® protected from clogging caused by product vapours
- flame transmission proof condensate drain
- maintenance friendly design
- modular design enables individual FLAMEFILTER® and valve pallets to be replaced

Pressure settings:

+3.5 mbar up to +210 mbar
+1.4 inch W.C. up to +84 inch W.C.
Higher pressure settings upon request.

Function and Description

The deflagration proof and endurance burning-proof P/EB-E type PROTEGO® valve is a highly developed pressure relief valve for large flows with an integrated flame arrester unit that is specially used for applications handling ethanol. It is primarily used as a safety device for flame transmission proof outbreathing on tanks, containers and process engineering apparatus. The valve offers reliable protection against excess pressure and prevents product losses almost up to the set pressure; it also protects against atmospheric deflagration as well as endurance burning if stabilized burning occurs. The PROTEGO® flame arrester unit is designed to achieve minimum pressure drop with maximum safety. The P/EB-E valve is available for substances of explosion group IIB1 (MESG ≥ 0.85 mm) and provides specific protection against deflagration and endurance burning of alcohol/air mixtures (such as ethanol/air).

The valve functions proportional, so the set pressures should be selected in relation to the proportional behaviour (such as a 10%, 40%, or 100% overpressure from the set pressure to the relieving pressure at which the required flow performance is reached).

The tank pressure is maintained up to set pressure with a tightness that is far superior to the conventional standard due to our



Demonstration of endurance burning
Video

Design Types and Specifications

The valve disc is weight-loaded. At set pressures >80 mbar (32.1 inch W.C.), an elongated design is used

There are two different designs:

Pressure relief valve, basic design

P/EB - E -

Pressure relief valve with heating jacket

P/EB - E -

(max. heating fluid temperature +85°C / 185°F)

Additional special devices available upon request

Table 1: Dimensions

Dimensions in mm / inches

To select the nominal size (DN), please use the flow capacity chart on the following page

DN	50 / 2"	50 / 2"	80 / 3"	80 / 3"
Set pressure	≤ +80 mbar ≤ +32.1 inch W.C.	> +80 mbar > +32.1 inch W.C.	≤ +80 mbar ≤ +32.1 inch W.C.	> +80 mbar > +32.1 inch W.C.
a	218 / 8.58	218 / 8.58	218 / 8.58	218 / 8.58
b	288 / 11.34	453 / 17.83	290 / 11.42	455 / 17.91

Dimensions for Pressure Relief Valve with heating jacket upon request

Table 2: Selection of explosion group

MESG	Expl. Gr. (IEC/CEN)	Gas Group (NEC)	Special approvals upon request
≥ 0,85 mm	IIB1	-	

Table 3: Material selection for housing

Design	B	C	Special materials upon request
Housing	Steel	Stainless Steel	
Heating jacket (P/EB-E-H-...)	Steel	Stainless Steel	
Valve seat	Stainless Steel	Stainless Steel	
Weather hood	Steel	Stainless Steel	

Table 4: Material combination of flame arrester unit

Design	A	Special materials upon request
FLAMEFILTER® cage	Stainless Steel	
FLAMEFILTER®	Stainless Steel	
Spacer	Stainless Steel	

Table 5: Material selection for valve pallet

Design	A	B	C	D	Special materials and higher pressure settings upon request
Pressure range (mbar) (inch W.C.)	+3.5 up to +5.0 +1.4 up to +2.0	>+5.0 up to +14 >+2.0 up to +5.6	>+14 up to +210 >+5.6 up to +84	>+14 up to +210 >+5.6 up to +84	
Valve pallet	Aluminium	Stainless Steel	Stainless Steel	Stainless Steel	
Sealing	FEP	FEP	Metal to Metal	PTFE	

Table 6: Flange connection type

EN 1092-1; Form B1	other types upon request
ASME B16.5; 150 lbs RFSF	



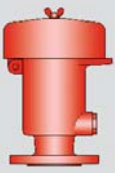

Pressure Relief Valve

Flow Capacity Chart

PROTEGO® P/EB-E

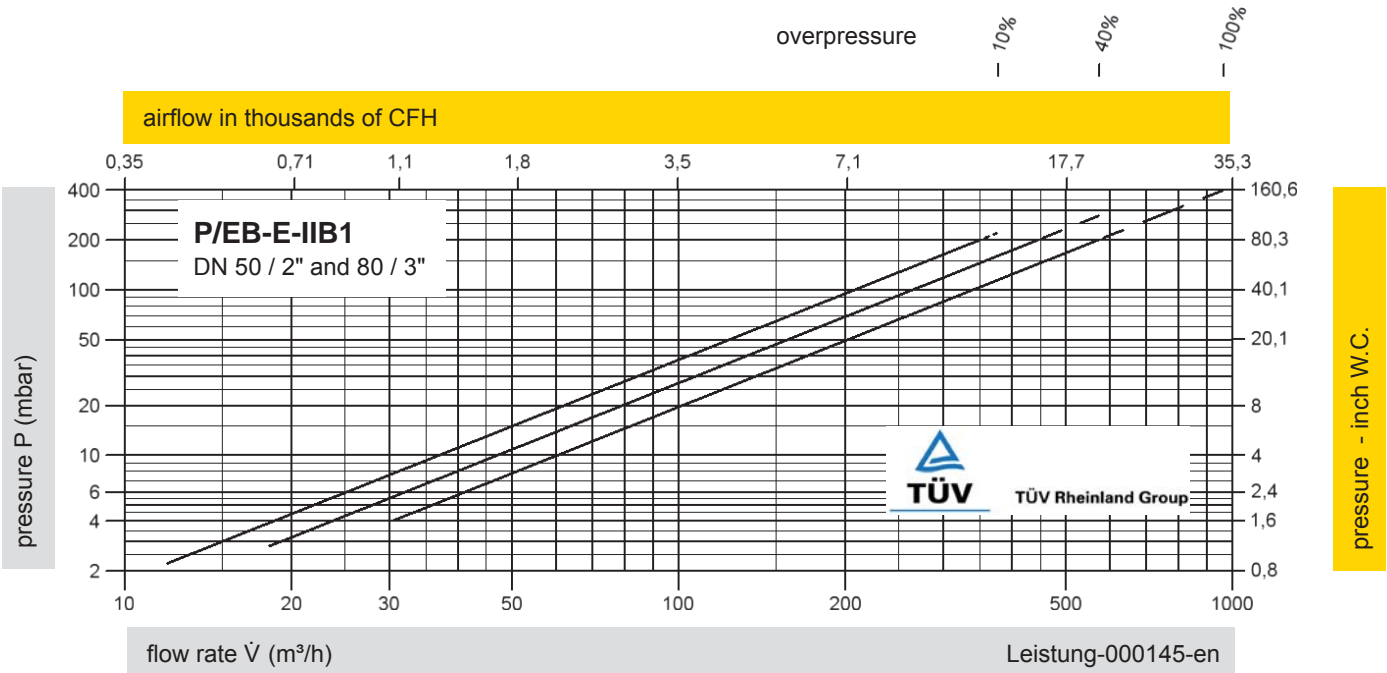

Remark

$$\text{set pressure} = \frac{\text{opening pressure resp. tank design pressure}}{1 + \frac{\text{overpressure \%}}{100\%}}$$

Set pressure = the valve starts to open

Opening pressure = set pressure plus overpressure

Overpressure % = percentage pressure increase over the set pressure

The flow capacity charts have been determined with a calibrated and TÜV certified flow capacity test rig. Volume flow \dot{V} in (m³/h) and CFH refer to the standard reference conditions of air ISO 6358 (20°C, 1bar). Conversion to other densities and temperatures refer to Vol. 1: "Technical Fundamentals".



Pressure Relief Valve

deflagration- and endurance burning-proof

PROTEGO® P/EBR

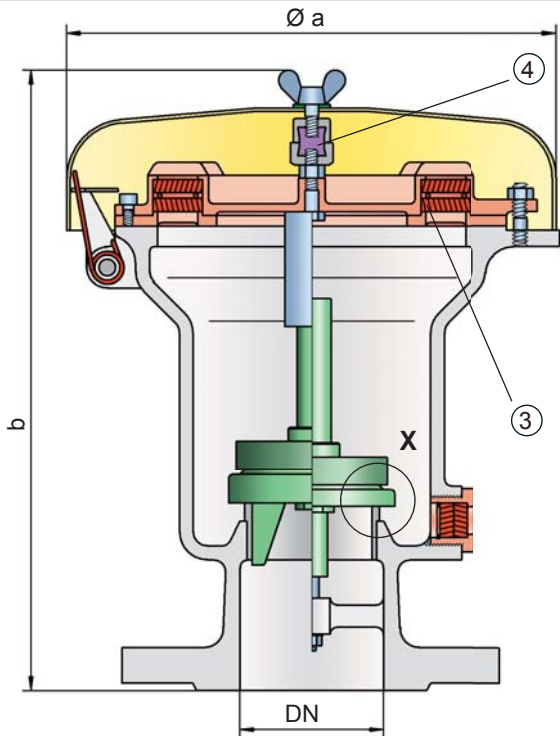

Detail X

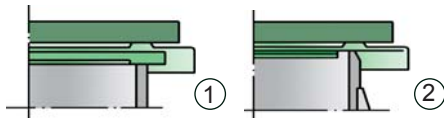

Pressure settings:

+3.5 mbar up to +210 mbar
+1.4 inch W.C. up to +84 inch W.C.
Higher pressure settings upon request.

Function and Description

The deflagration-proof and endurance burning-proof P/EBR type PROTEGO® valve is a highly developed pressure relief valve for large flows with an integrated flame arrester unit. It is primarily used as a safety device for flame transmission proof outbreathing on tanks, containers and process engineering apparatus. The valve offers reliable protection against excess pressure and prevents product losses almost up to the set pressure; it also protects against atmospheric deflagration as well as endurance burning if stabilized burning occurs. The PROTEGO® flame arrester unit is designed to achieve minimum pressure drop with maximum safety. P/EBR valves are available for substances from explosion groups IIA and IIB3 (NEC group D and C MESH ≥ 0.65 mm).

If the set pressure is reached for a valve approved for explosion Group IIA (NEC group D), the valve starts to open and reaches full lift within 10% overpressure. This unique 10% technology enables a set pressure that is only 10% below the maximum allowable working pressure (MAWP) of the tank. After years of development, this typical opening characteristic of a safety relief valve is now also available for the low pressure range. Valves approved for explosion group IIB3 (NEC group C) function proportionally, so the set pressures should be selected in relation to the proportional behaviour (such as a 10%, 40%, or 100% overpressure from the set pressure to the relieving pressure at which the required flow performance is reached).

The tank pressure is maintained up to the set pressure with a tightness that is far superior to the conventional standard due to our state of the art manufacturing technology. This feature is ensured by the valve seats made of high quality stainless steel and with individually lapped valve pallets (1) or with an air cushion seal (2) in conjunction with high quality FEP diaphragm. The valve pallets are also available with a PTFE seal to prevent the valve pallets from sticking when sticky products are used and to enable the use of corrosive fluids. After the excess pressure is discharged, the valve reseats and provides a tight seal.

If the set pressure is exceeded, explosive gas/product-vapour air mixtures are released to the atmosphere. If this mixture ignites, the integrated PROTEGO® flame arrester unit (3) prevents flame transmission into the tank. If additional mixture continues to flow and stabilized burning occurs, the integrated flame arrester unit prevents flashback as a result from endurance burning. The valve is protected and also fulfils its function under this severe service conditions. The spring loaded weather hood opens as soon as the fusible element (4) melts.

The valve can be used up to an operating temperature of +60°C / 140°F and meets the requirements of European tank design standard EN 14015 – Appendix L and ISO 28300 (API 2000).

Type-approved in accordance with the current ATEX Directive as well as other international standards.

Special Features and Advantages

- requires only 10% overpressure to full lift for group IIA (NEC group D >0.9 MESH) vapours
- through 10% technology higher set pressures can be used which results in product loss reduction compared to conventional 40% and 100% overpressure technology vents (compare API 2000)
- more design flexibility through higher reseating pressures; vents reseal when conventional vent is still discharging costly product or nitrogen
- the valve disc is guided within the housing to protect against harsh weather conditions
- high performance seal reducing product loss below EPA's 500ppm rule preventing environmental pollution
- can be used as protective system according to ATEX in areas subject to explosion hazards
- safe against deflagration and endurance burning for explosion group IIA and IIB3 (NEC group D and C) vapours
- high flow capacity through large FLAMEFILTER® cross-section, results in low pressure drop
- PROTEGO® flame arrester unit provides protection against atmospheric deflagration and endurance burning
- flame arrester unit integrated into the valve saves space, weight and reduces cost
- FLAMEFILTER® protected from clogging caused by product vapours
- flame transmission proof condensate drain
- maintenance friendly design
- modular design enables individual FLAMEFILTER® and valve pallets to be replaced



Vents - 10% Technology
(Flyer pdf)



Leak Rate/10% Technology
(Flyer pdf)



Demonstration of endurance burning
Video

Design Types and Specifications

The valve disc is weight-loaded. At set pressures >80 mbar (32.1 inch W.C.), an elongated design is used

There are two different designs:

Pressure relief valve, basic design

P/EBR -

Pressure relief valve with heating jacket

P/EBR -

(max. heating fluid temperature +85°C / 185°F)

Additional special devices available upon request

Table 1: Dimensions

Dimensions in mm / inches

To select the nominal size (DN), please use the flow capacity charts on the following pages

DN	80 / 3"	80 / 3"	100 / 4"	100 / 4"
Set pressure	≤ +80 mbar ≤ +32.1 inch W.C.	> +80 mbar > +32.1 inch W.C.	≤ +80 mbar ≤ +32.1 inch W.C.	> +80 mbar > +32.1 inch W.C.
a	353 / 13.90	353 / 13.90	353 / 13.90	353 / 13.90
b	345 / 13.58	505 / 19.88	345 / 13.58	505 / 19.88

Dimensions for Pressure Relief Valve with heating jacket upon request

Table 2: Selection of explosion group

MESG	Expl. Gr. (IEC/CEN)	Gas Group (NEC)	
> 0,90 mm	IIA	D	Special approvals upon request
> 0,65 mm	IIB3	C	

Table 3: Material selection for housing

Design	B	C	
Housing	Steel	Stainless Steel	Special materials upon request
Heating jacket (P/EBR-H-...)	Steel	Stainless Steel	
Valve seat	Stainless Steel	Stainless Steel	
Weather hood	Steel	Stainless Steel	

Table 4: Material combination of flame arrester unit

Design	A	
FLAMEFILTER® cage	Stainless Steel	Special materials upon request
FLAMEFILTER®	Stainless Steel	
Spacer	Stainless Steel	

Table 5: Material selection for valve pallet

Design	A	B	C	D	
Pressure range (mbar) (inch W.C.)	+3.5 up to +5.0 +1.4 up to +2.0	>+5.0 up to +14 >+2.0 up to +5.6	>+14 up to +210 >+5.6 up to +84	>+14 up to +210 >+5.6 up to +84	Special materials and higher pressure settings upon request
Valve pallet	Aluminium	Stainless Steel	Stainless Steel	Stainless Steel	
Sealing	FEP	FEP	Metal to Metal	PTFE	

Table 6: Flange connection type

EN 1092-1; Form B1	other types upon request
ASME B16.5; 150 lbs RFSF	



PROTEGO
for safety and environment



Pressure Relief Valve

Flow Capacity Charts

PROTEGO® P/EBR

airflow in thousands of CFH

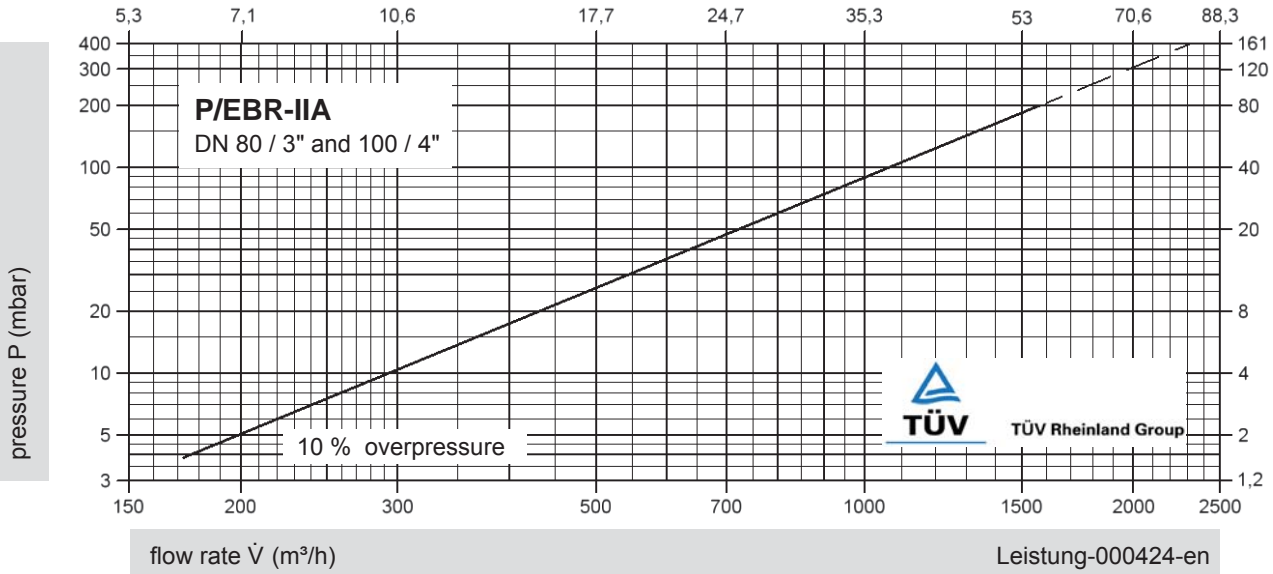

airflow in thousands of CFH

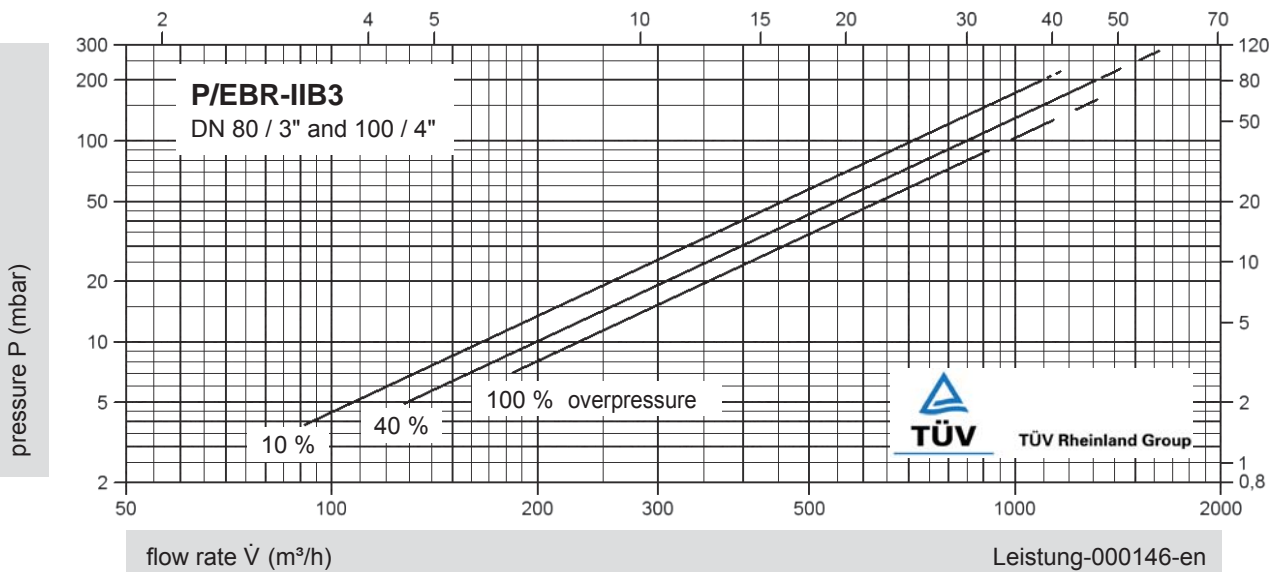

Remark

$$\text{set pressure} = \frac{\text{opening pressure resp. tank design pressure}}{1 + \frac{\text{overpressure \%}}{100\%}}$$

Set pressure = the valve starts to open

Opening pressure = set pressure plus overpressure

Overpressure % = percentage pressure increase over the set pressure

The flow capacity charts have been determined with a calibrated and TÜV certified flow capacity test rig.
Volume flow \dot{V} in (m³/h) and CFH refer to the standard reference conditions of air ISO 6358 (20°C, 1bar).
Conversion to other densities and temperatures refer to Vol. 1: "Technical Fundamentals".



Pressure Relief Valve

deflagration- and endurance burning-proof

PROTEGO® P/EBR-E

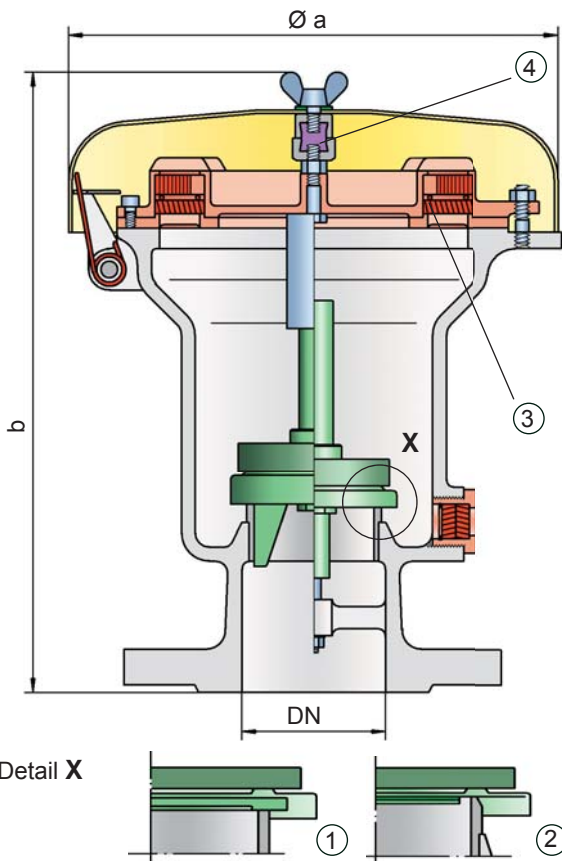

to our state of the art manufacturing technology. This feature is ensured by the valve seats made of high quality stainless steel and with individually lapped valve pallets (1) or with an air cushion seal (2) in conjunction with high quality FEP diaphragm. The valve pallets are also available with a PTFE seal to prevent the valve pallets from sticking when sticky products are used and to enable the use of corrosive fluids. After the excess pressure is discharged, the valve reseats and provides a tight seal.

If the set pressure is exceeded, explosive gas/product-vapour air mixtures are released to the atmosphere. If this mixture ignites, the integrated PROTEGO® flame arrester unit (3) prevents flame transmission into the tank. If additional mixture continues to flow and stabilized burning occurs, the integrated flame arrester unit prevents flashback as a result of endurance burning. The valve is protected and also fulfils its function under these severe service conditions. The spring loaded weather hood opens as soon as the fusible element (4) melts.

The valve can be used up to an operating temperature of +60°C / 140°F and meets the requirements of European tank design standard EN 14015 – Appendix L and ISO 28300 (API 2000).

Type-approved in accordance with the current ATEX Directive and EN ISO 16852 as well as other international standards.

Special Features and Advantages

- selecting set pressure close to relieving pressure results in product loss reduction
- more design flexibility through higher reseating pressures; vents reseal when conventional vent is still discharging costly product or nitrogen
- the valve disc is guided within the housing to protect against harsh weather conditions
- high performance seal reducing product loss below EPA's 500ppm rule preventing environmental pollution
- can be used as protective system according to ATEX in areas subject to explosion hazards
- safe against deflagration and endurance burning of alcohol/air mixtures from explosion group IIB1
- high flow capacity through large flame filter cross-section, results in low pressure drop
- PROTEGO® flame arrester unit provides protection against atmospheric deflagration and endurance burning
- flame arrester unit integrated into the valve saves space, weight and reduces cost
- FLAMEFILTER® protected from clogging caused by product vapours
- flame transmission proof condensate drain
- maintenance friendly design
- modular design enables individual FLAMEFILTER® and valve pallets to be replaced

Pressure settings:

+3.5 mbar up to +210 mbar
+1.4 inch W.C. up to +84 inch W.C.
Higher pressure settings upon request.

Function and Description

The deflagration proof and endurance burning proof P/EBR-E type PROTEGO® valve is a highly developed pressure relief valve for large flows with an integrated flame arrester unit that is specially used for applications handling ethanol. It is primarily used as a safety device for flame transmission proof outbreathing on tanks, containers and process engineering apparatus. The valve offers reliable protection against excess pressure and prevents product losses almost up to the set pressure; it also protects against atmospheric deflagration as well as endurance burning if stabilized burning occurs. The PROTEGO® flame arrester unit is designed to achieve minimum pressure drop with maximum safety. The P/EBR-E valve is available for substances of explosion group IIB1 (MESG ≥ 0.85 mm) and provides specific protection against deflagration and endurance burning of alcohol/air mixtures (such as ethanol/air).

The valve functions proportionally, so the set pressures should be selected in relation to the proportional behaviour (such as a 10%, 40%, or 100% overpressure from the set pressure to the relieving pressure at which the required flow performance is reached).

The tank pressure is maintained up to the set pressure with a tightness that is far superior to the conventional standard due



Demonstration of endurance burning
Video

Design Types and Specifications

The valve disc is weight-loaded. At set pressures >80 mbar (32.1 inch W.C.), an elongated design is used

There are two different designs:

Pressure relief valve, basic design

P/EBR - E -

Pressure relief valve with heating jacket
(max. heating fluid temperature +85°C / 185°F)

P/EBR - E -

Additional special devices available upon request

Table 1: Dimensions				Dimensions in mm / inches	
To select the nominal size (DN), please use the flow capacity chart on the following page					
DN	80 / 3"	80 / 3"	100 / 4"	100 / 4"	
Set pressure	≤ +80 mbar ≤ +32.1 inch W.C.	> +80 mbar > +32.1 inch W.C.	≤ +80 mbar ≤ +32.1 inch W.C.	> +80 mbar > +32.1 inch W.C.	
a	353 / 13.90	353 / 13.90	353 / 13.90	353 / 13.90	
b	345 / 13.58	505 / 19.88	345 / 13.58	505 / 19.88	

Dimensions for Pressure Relief Valve with heating jacket upon request

Table 2: Selection of explosion group			
MESG	Expl. Gr. (IEC/CEN)	Gas Group (NEC)	Special approvals upon request
≥ 0,85 mm	IIB1	-	

Table 3: Material selection for housing			
Design	B	C	Special materials upon request
Housing	Steel	Stainless Steel	
Heating jacket (P/EBR-E-H-...)	Steel	Stainless Steel	
Valve seat	Stainless Steel	Stainless Steel	
Weather hood	Steel	Stainless Steel	

Table 4: Material combination of flame arrester unit	
Design	A
FLAMEFILTER® cage	Stainless Steel
FLAMEFILTER®	Stainless Steel
Spacer	Stainless Steel

Special materials upon request

Table 5: Material selection for valve pallet					
Design	A	B	C	D	Special materials and higher pressure settings upon request
Pressure range (mbar) (inch W.C.)	+3.5 up to +5.0 +1.4 up to +2.0	>+5.0 up to +14 >+2.0 up to +5.6	>+14 up to +210 >+5.6 up to +84	>+14 up to +210 >+5.6 up to +84	
Valve pallet	Aluminium	Stainless Steel	Stainless Steel	Stainless Steel	
Sealing	FEP	FEP	Metal to Metal	PTFE	

Table 6: Flange connection type	
EN 1092-1; Form B1	other types upon request
ASME B16.5; 150 lbs RFSF	



Pressure Relief Valve

Flow Capacity Chart

PROTEGO® P/EBR-E

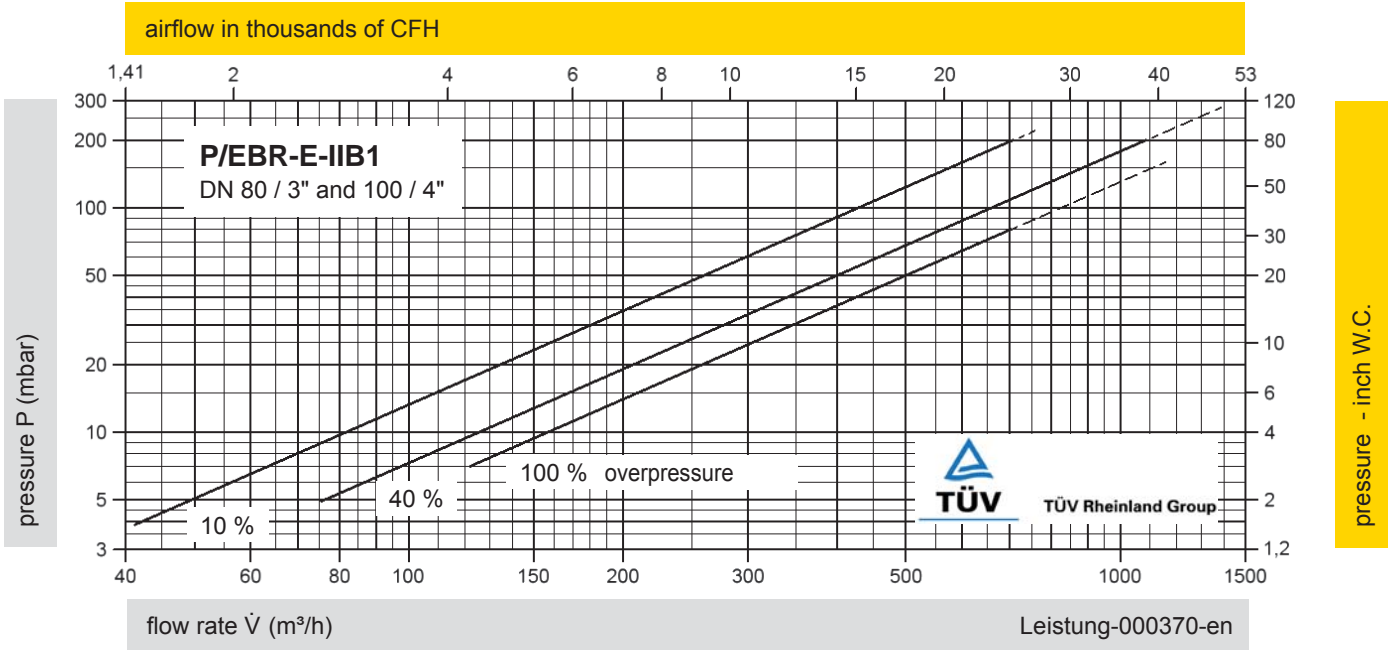

Remark

$$\text{set pressure} = \frac{\text{opening pressure resp. tank design pressure}}{1 + \frac{\text{overpressure \%}}{100\%}}$$

Set pressure = the valve starts to open

Opening pressure = set pressure plus overpressure

Overpressure % = percentage pressure increase over the set pressure

The flow capacity charts have been determined with a calibrated and TÜV certified flow capacity test rig. Volume flow \dot{V} in (m³/h) and CFH refer to the standard reference conditions of air ISO 6358 (20°C, 1bar). Conversion to other densities and temperatures refer to Vol. 1: "Technical Fundamentals".

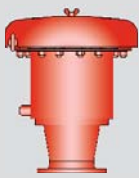

Pressure Relief Valve

deflagration- and endurance burning-proof

PROTEGO® D-SVL-EB-IIA

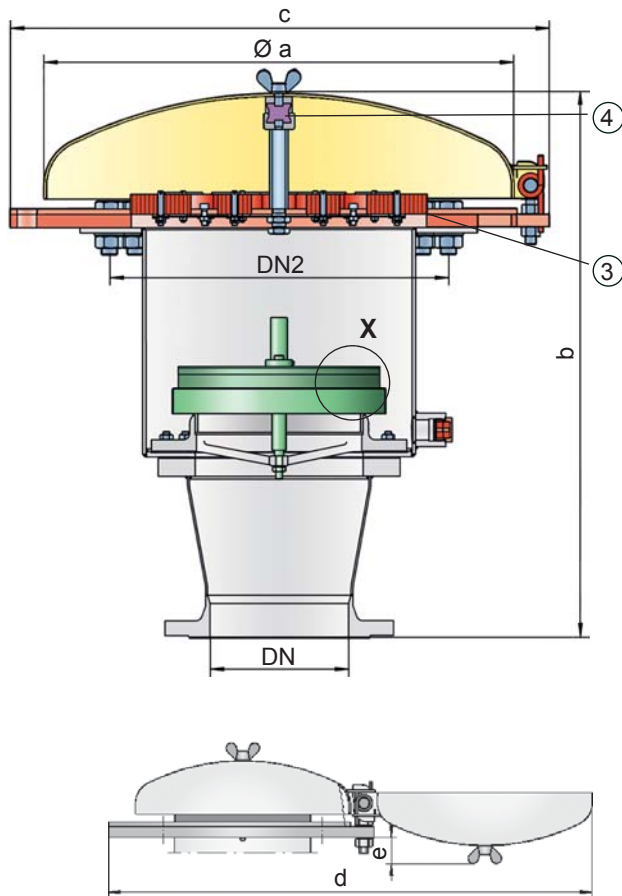

Detail X

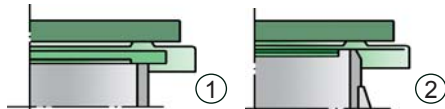

Pressure settings:

+2.0 mbar up to +60 mbar
+0.8 inch W.C. up to +24 inch W.C.

Higher pressure settings upon request.

Function and Description

The deflagration-proof and endurance burning-proof D-SVL-EB type PROTEGO® valve is a highly developed pressure relief valve for large flows with an integrated flame arrester PROTEGO® EB. It is primarily used as a safety device for flame transmission proof outbreathing on tanks, containers and process engineering apparatus. The valve offers reliable protection against excess pressure and prevents product losses almost up to the set pressure; it also protects against atmospheric deflagration as well as endurance burning if stabilized burning occurs. The PROTEGO® flame arrester unit is designed to achieve minimum pressure drop with maximum safety. PROTEGO® D-SVL-EB valves are available for substances of explosion group IIA (NEC group D MESH > 0.9 mm).

When the set pressure is reached, the valve starts to open and reaches full lift within 10% overpressure. This unique 10% technology enables a set pressure that is only 10% below the maximum allowable working pressure (MAWP) of the tank. After years of development, this typical opening characteristic of a safety relief valve is now also available for the low pressure range.

The tank pressure is maintained up to the set pressure with a tightness that is far superior to the conventional standard due to our state of the art manufacturing technology. This feature is ensured by the valve seats made of high quality stainless steel and with individually lapped valve pallets (1) or with an air cushion seal (2) in conjunction with a high quality FEP diaphragm. The valve pallets are also available with a PTFE seal to prevent the valve pallets from sticking when sticky products are used and to enable the use in corrosive fluids. After the excess pressure is discharged, the valve reseats and provides a tight seal.

If the set pressure is exceeded, explosive gas/product-vapour air mixtures are released to the atmosphere. If this mixture ignites, the integrated flame arrester PROTEGO® EB (3) prevents flame transmission into the tank. If additional mixture continues to flow and stabilized burning occurs, the integrated flame arrester unit prevents flashback as a result from endurance burning. The valve is protected and also fulfils its function under this severe service conditions. The spring loaded weather hood opens as soon as the fusible element (4) melts.

The valve can be used up to an operating temperature of +60°C / 140°F and meets the requirements of European tank design standard EN 14015 – Appendix L and ISO 28300 (API 2000).

Type-approved in accordance with the current ATEX Directive and EN ISO 16852 as well as other international standards.

Special Features and Advantages

- requires only 10% overpressure to full lift
- through 10% technology higher set pressures can be used which results in product loss reduction compared to conventional 40% and 100% overpressure technology vents (compare API 2000)
- more design flexibility through higher reseating pressures; vents reseal when conventional vent is still discharging costly product or nitrogen
- high performance seal reducing product loss below EPA's 500ppm rule preventing environmental pollution
- the valve disc is guided within the housing to protect against harsh weather conditions
- can be used as protective system according ATEX in areas subject to explosion hazards
- PROTEGO® flame arrester unit provides protection against atmospheric deflagration and endurance burning
- flame arrester unit integrated into the valve saves space, weight and reduces cost
- flame arrester unit protected from clogging through product vapour
- flame arrester unit has a low pressure drop
- flame transmission proof condensate drain
- maintenance friendly design
- modular design enables individual FLAMEFILTER® and valve pallet to be replaced



Vents - 10% Technology
(Flyer pdf)



Leak Rate/10% Technology
(Flyer pdf)



Demonstration of endurance burning
Video

Design Types and Specifications

The valve disc is weight-loaded.

There are two different designs:

Pressure relief valve, basic design

D-SVL-EB -

Pressure relief valve with heating jacket

D-SVL-EB -

Additional special devices available upon request

Table 1: Dimensions

Dimensions in mm / inches

DN	DN2	a	b	c	d	e
150 / 6"	400 / 16"	705 / 27.76	754 / 29.68	802 / 31.57	1500 / 59.06	109 / 4.29
200 / 8"	400 / 16"	705 / 27.76	846 / 33.31	802 / 31.57	1500 / 59.06	109 / 4.29

Dimensions for Pressure Relief Valve with heating jacket upon request

Table 2: Selection of explosion group

MESG	Expl. Gr. (IEC/CEN)	Gas Group (NEC)	Special approvals upon request
> 0,90 mm	IIA	D	

Table 3: Material selection for housing

Design	A	B	Special materials upon request
Housing	Steel	Stainless Steel	
Heating jacket (D-SVL-EB-H-...)	Steel	Stainless Steel	
Valve seat	Stainless Steel	Stainless Steel	
Spacer	PTFE	PTFE	
Flange ring	Steel	Stainless Steel	
Weather hood	Steel	Stainless Steel	
Flame arrester unit	A	A, B	

Table 4: Material combination of flame arrester unit

Design	A	B	Special materials upon request
FLAMEFILTER® cage	Steel	Stainless Steel	
FLAMEFILTER®	Stainless Steel	Stainless Steel	
Safety bar	Stainless Steel	Stainless Steel	

Table 5: Material selection for valve pallet

Design	A	B	C	D	E	F
Pressure range (mbar) (inch W.C.)	+2.0 up to +3.5 +0.8 up to +1.4	>+3.5 up to +14 >+1.4 up to +5.6	>+14 up to +35 >+5.6 up to +14	>+35 up to +60 >+14 up to +24	>+14 up to +35 >+5.6 up to +14	>+35 up to +60 >+14 up to +24
Valve pallet	Aluminium	Stainless Steel	Stainless Steel	Stainless Steel	Stainless Steel	Stainless Steel
Sealing	FEP	FEP	Metal to Metal	Metal to Metal	PTFE	PTFE

Special materials and higher pressure settings upon request

Table 6: Flange connection type

EN 1092-1; Form B1	other types upon request
ASME B16.5; 150 lbs RFSF	



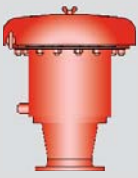

Pressure Relief Valve

Flow Capacity Chart

PROTEGO® D-SVL-EB-IIA

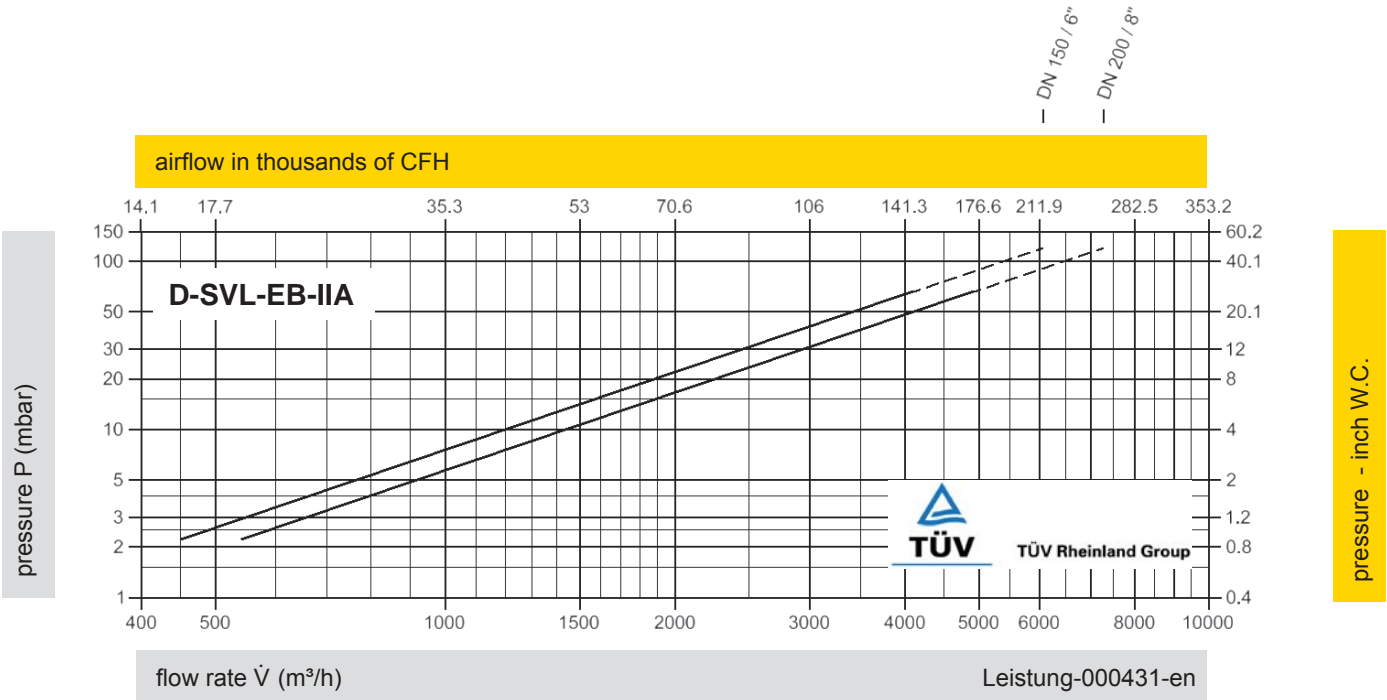

The flow capacity charts have been determined with a calibrated and TÜV certified flow capacity test rig. Volume flow \dot{V} in (m^3/h) and CFH refer to the standard reference conditions of air ISO 6358 (20°C, 1bar). Conversion to other densities and temperatures refer to Vol. 1: "Technical Fundamentals".

Notes:

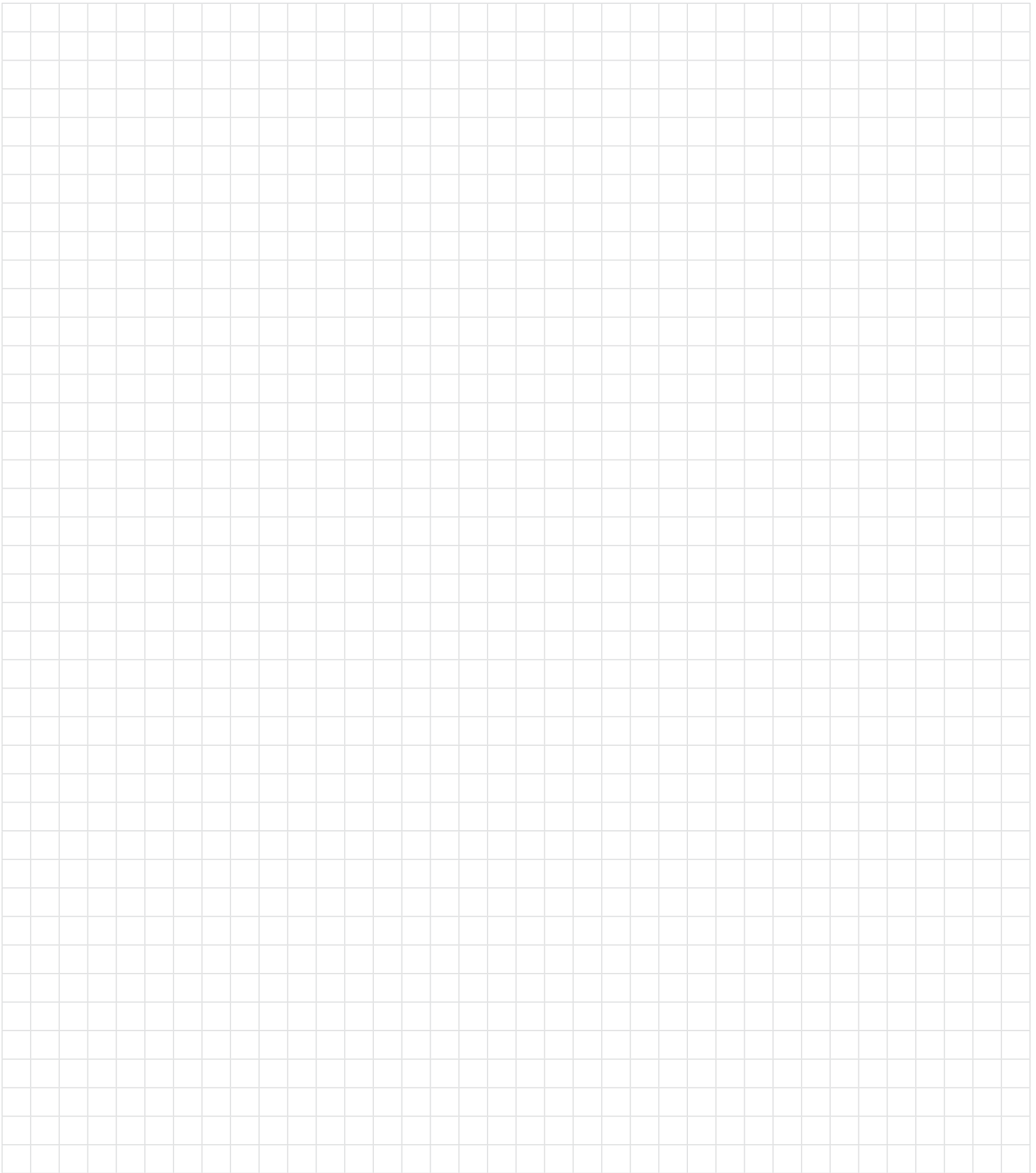

for safety and environment

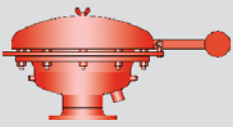

Pressure Relief Valve

deflagration- and endurance burning-proof

PROTEGO® BE/HR-D

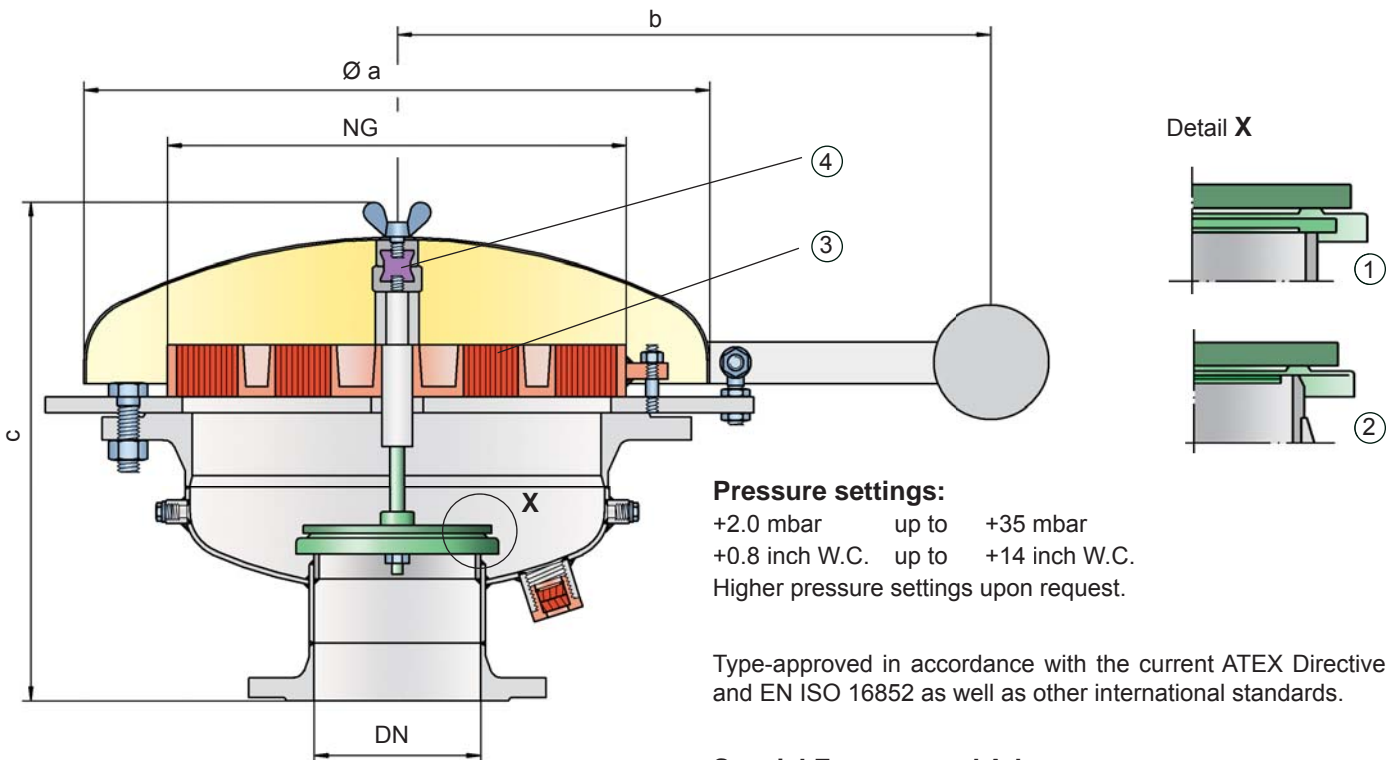

Pressure settings:

+2.0 mbar up to +35 mbar
 +0.8 inch W.C. up to +14 inch W.C.
 Higher pressure settings upon request.

Type-approved in accordance with the current ATEX Directive and EN ISO 16852 as well as other international standards.

Function and Description

The deflagration-proof and endurance burning-proof BE/HR-D type PROTEGO® valve is a highly developed pressure relief valve with an integrated flame arrester unit. It is primarily used as a safety device for flame transmission proof outbreathing on tanks, containers and process engineering apparatus. The valve offers reliable protection against excess pressure and prevents product losses almost up to the set pressure; it also protects against atmospheric deflagration as well as endurance burning if stabilized burning occurs. The PROTEGO® flame arrester unit is designed to achieve minimum pressure drop with maximum safety. The BE/HR-D valve is available for substances of explosion group IIA (NEC group D MESH > 0.9 mm).

When the set pressure is reached, the valve starts to open and reaches full lift within 40% overpressure. The tank pressure is maintained up to the set pressure with a tightness that is far superior to the conventional standard due to our state of the art manufacturing technology. This feature is ensured by the valve seats made of high quality stainless steel and with individually lapped valve pallets (1) or with an air cushion seal (2) in conjunction with high quality FEP diaphragm. After the excess pressure is discharged, the valve reseats and provides a tight seal.

If the set pressure is exceeded, explosive gas/product-vapour air mixtures are released to the atmosphere. If this mixture ignites, the integrated PROTEGO® flame arrester unit (3) prevents flame transmission into the tank. If additional mixture continues to flow and stabilized burning occurs, the integrated flame arrester unit prevents flashback as a result from endurance burning. The valve is protected and also fulfils its function under this severe service conditions. The spring loaded weather hood opens as soon as the fusible element (4) melts.

The valve can be used up to an operating temperature of +60°C / 140°F and meets the requirements of European tank design standard EN 14015 – Appendix L and ISO 28300 (API 2000).

Special Features and Advantages

- requires only 40% overpressure to full lift
- through 40% technology higher set pressures can be used which results in product loss reduction compared to conventional 100% overpressure technology vents (compare API 2000)
- more design flexibility through higher reseating pressures; vents reseal when conventional vent is still discharging costly product or nitrogen
- high performance seal reducing product loss below EPA's 500ppm rule preventing environmental pollution
- the valve disc is guided within the housing to protect against harsh weather conditions
- can be used as protective system according to ATEX in areas subject to explosion hazards
- high flow capacity through large FLAMEFILTER® cross-section, results in low pressure drop
- FLAMEFILTER® provides protection against atmospheric deflagration and endurance burning
- FLAMEFILTER® integrated into the valve saves space, weight and reduces cost
- FLAMEFILTER® protected from clogging through product vapours
- flame-transmission-proof condensate drain
- maintenance-friendly design

Design and Specifications

The valve disc is weight-loaded.

Pressure relief valve, basic design

BE/HR-D-400/...

Additional special devices available upon request



Demonstration of endurance burning
Video

Table 1: Dimensions

Dimensions in mm / inches

To select the nominal size (DN), please use the flow capacity chart on the following page

DN	150 / 6"	200 / 8"	NG = Nominal size
NG	400 / 16"	400 / 16"	
a	600 / 23.62	600 / 23.62	
b	545 / 21.46	545 / 21.46	
c	485 / 19.09	485 / 19.09	

Table 2: Selection of explosion group

MESG	Expl. Gr. (IEC/CEN)	Gas Group (NEC)	Special approvals upon request
> 0,90 mm	IIA	D	

Table 3: Material selection for housing

Design	A	B	Special materials upon request
Housing	Steel	Stainless Steel	
Valve seat	Stainless Steel	Stainless Steel	
Weather hood	Steel	Stainless Steel	
Flame arrester unit	A	B	

Table 4: Material combinations of flame arrester unit

Design	A	B	Special materials upon request
FLAMEFILTER® cage	Steel	Stainless Steel	
FLAMEFILTER®	Stainless Steel	Stainless Steel	

Table 5: Material selection for valve pallet

Design	A	B	C	Special materials and higher pressure settings upon request
Pressure range (mbar) (inch W.C.)	+2.0 up to +3.5	>+3.5 up to +14	>+14 up to +35	
	+0.8 up to +1.4	>+1.4 up to +5.6	>+5.6 up to +14	
Valve pallet	Aluminium	Stainless Steel	Stainless Steel	
Sealing	FEP	FEP	Metal to Metal	

Table 6: Flange connection type

EN 1092-1; Form B1	other types upon request
ASME B16.5; 150 lbs RF5F	



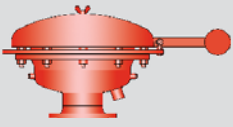

Pressure Relief Valve

Flow Capacity Chart

PROTEGO® BE/HR-D

DN 150 / 6"
DN 200 / 8"

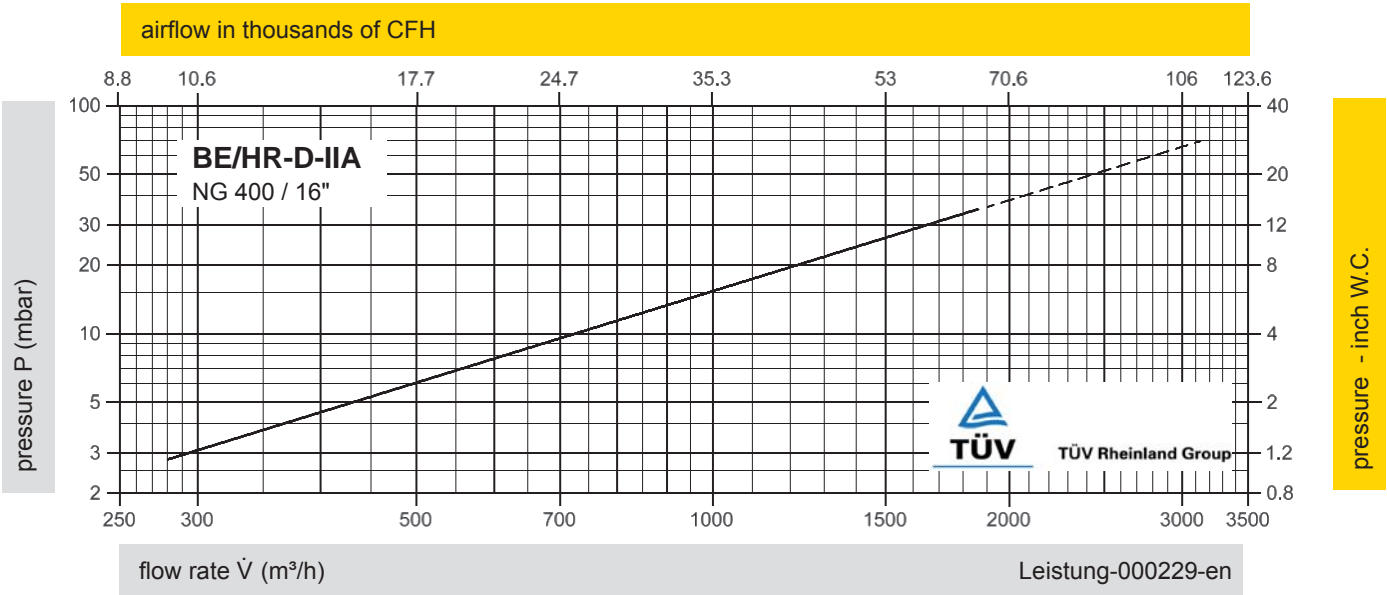

Remark

$$\text{set pressure} = \frac{\text{opening pressure resp. tank design pressure}}{1,4}$$

Set pressure = the valve starts to open

Opening pressure = set pressure plus overpressure

Overpressure = pressure increase over the set pressure

The flow capacity charts have been determined with a calibrated and TÜV certified flow capacity test rig. Volume flow \dot{V} in (m³/h) and CFH refer to the standard reference conditions of air ISO 6358 (20°C, 1bar). Conversion to other densities and temperatures refer to Vol. 1: "Technical Fundamentals".

Notes:

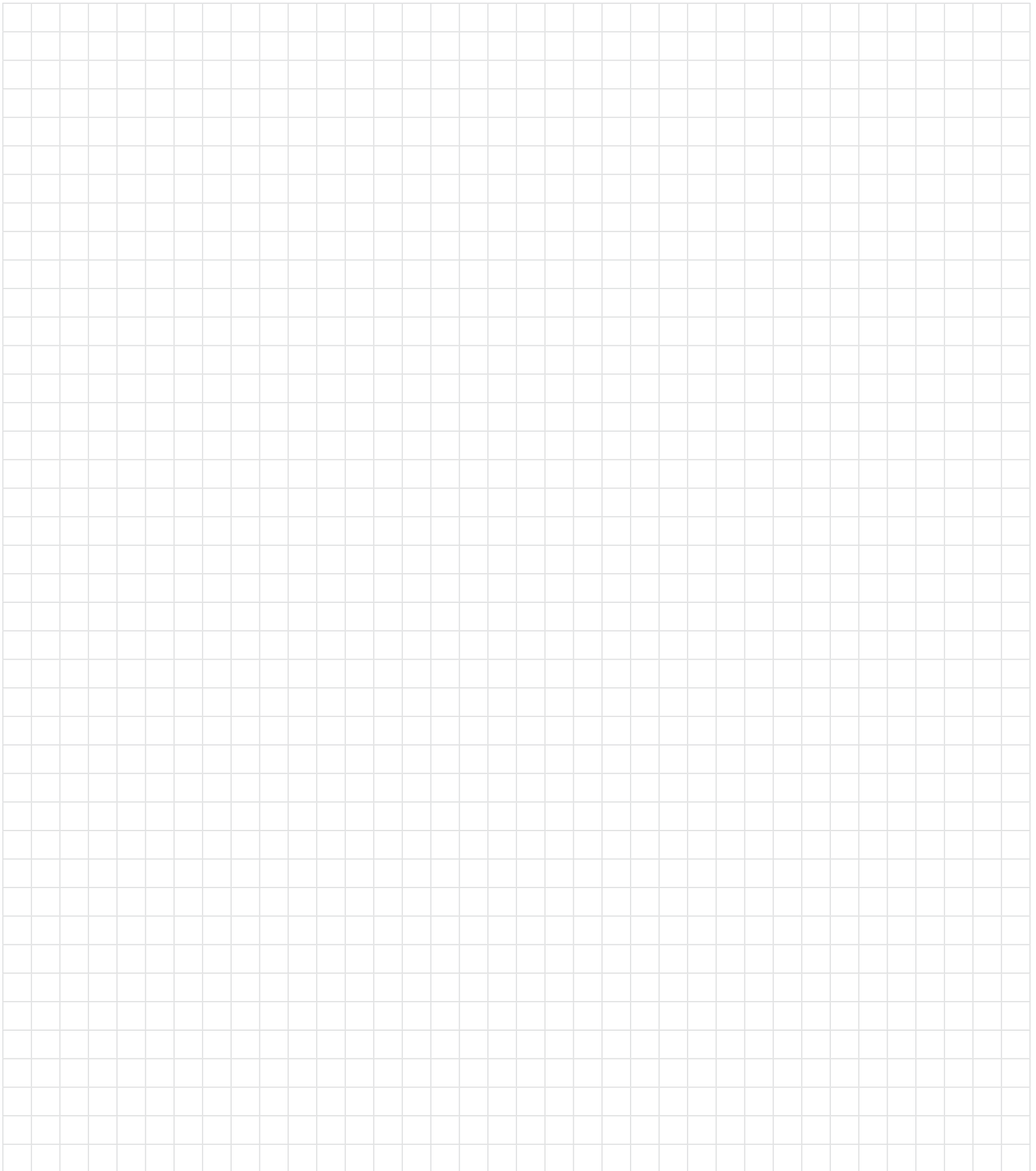

for safety and environment

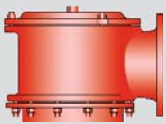

Vacuum Relief Valve deflagration-proof

PROTEGO® SV/E

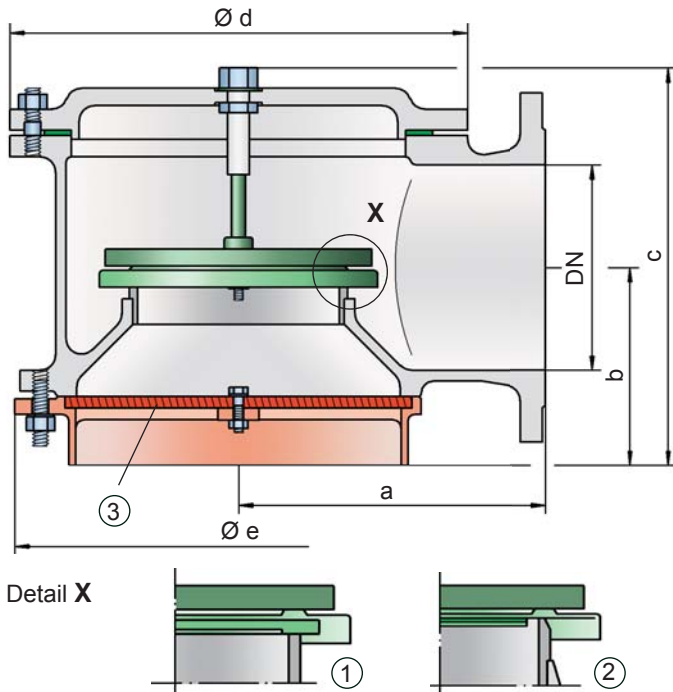

Vacuum settings:

-2.0 mbar up to -60 mbar (-0.2 kPa up to -6 kPa)
-0.8 inch W.C. up to -24 inch W.C.
Higher vacuum settings upon request

Function and Description

The deflagration-proof SV/E type PROTEGO® valve is a state of the art vacuum relief valve with an integrated flame arrester unit. It is primarily used as a safety device for flame transmission proof inbreathing on tanks, containers and process engineering apparatus. The valve offers reliable protection against vacuum and prevents inbreathing of air almost up to the set pressure; it also protects against atmospheric deflagration. The PROTEGO® flame arrester unit is designed to achieve minimum pressure drop with maximum safety. The PROTEGO® SV/E valve is available for substances from explosion groups IIA to IIC.

When the set vacuum is reached, the valve starts to open and reaches full lift within 10% overpressure. This unique 10% technology enables a set vacuum that is only 10% above the maximum allowable working vacuum (MAWV) of the tank. After years of development, this typical opening characteristic of a safety relief valve is now also available for the low pressure range.

The tank pressure is maintained up to the set vacuum with a tightness that is far superior to the conventional standard due to our state of the art manufacturing technology. This feature is ensured by the valve seats made of high quality stainless steel and with individually lapped valve pallets (1) or with an air cushion seal (2) in conjunction with high quality FEP diaphragm. The valve pallets are also available with a PTFE seal to prevent the valve pallets from sticking when sticky products are used and to enable the use of corrosive fluids. After the vacuum is equalized, the valve reseats and provides a tight seal.

If the valve is used in atmospheres forming an explosive mixture with air and the mixture ignites, the integrated PROTEGO® flame arrester unit (3) prevents flame transmission into the tank.

The standard design is tested at an operating temperature up to +60°C / 140°F and meets the requirements of European tank design standard EN 14015 – Appendix L and ISO 28300 (API 2000). In addition numerous versions for higher operating temperature are available.

Type-approved in accordance with the current ATEX Directive and EN ISO 16852 as well as other international standards. Additional certificates from classification associations for use on ships are also available.

Special Features and Advantages

- requires only 10% overpressure to full lift
- extreme tightness and hence least possible product losses and reduced environmental pollution
- through 10% technology lower set vacuum can be reached which results in product loss reduction compared to conventional 40% and 100% overpressure technology vents (compare API 2000)
- optimized flow performance
- the valve disc is guided within the housing to protect against harsh weather conditions
- can be used as protective system according ATEX in areas subject to explosion hazards
- FLAMEFILTER® provides protection against atmospheric deflagration
- FLAMEFILTER® integrated into the valve saves space, weight and reduces cost
- FLAMEFILTER® protected from clogging through product vapour
- PROTEGO® flame arrester unit has a low pressure drop
- maintenance friendly design
- modular design enables individual FLAMEFILTER® and valve pallets to be replaced
- an additional lifting gear can be purchased

Design Types and Specifications

The valve disc is weight-loaded. **Higher vacuum can be achieved upon request with a special spring loaded design.**

There are four different designs:

Vacuum relief valve, basic design	SV/E-[-]-[-]
Vacuum relief valve with heating jacket (max. heating fluid temperature +85°C / 185°F)	SV/E-[-]-[H]
Vacuum relief valve with lifting gear (ship design)	SV/E-[S]-[-]
Vacuum relief valve with lifting gear (ship design) and heating jacket (max. heating fluid temperature +85°C / 185°F)	SV/E-[S]-[H]

Additional special devices available upon request



Vents - 10% Technology
(Flyer pdf)



Leak Rate/10% Technology
(Flyer pdf)

Table 1: Dimensions

Dimensions in mm / inches

To select the nominal size (DN), please use the flow capacity chart on the following page

DN	50 / 2"	80 / 3"	100 / 4"	150 / 6"	200 / 8"	250 / 10"	300 / 12"
a	140 / 5.51	170 / 6.69	190 / 7.48	230 / 9.06	300 / 11.81	325 / 12.80	425 / 16.73
b	105 / 4.13	115 / 4.53	125 / 4.92	165 / 6.50	195 / 7.68	230 / 9.06	280 / 11.02
c	225 / 8.86	240 / 9.45	320 / 12.60	410 / 16.14	460 / 18.11	525 / 20.67	575 / 22.64
d	170 / 6.69	235 / 9.25	280 / 11.02	335 / 13.19	445 / 17.52	505 / 19.88	505 / 19.88
e	215 / 8.46	215 / 8.46	255 / 10.04	345 / 13.58	435 / 17.13	470 / 18.50	635 / 25.00

Table 2: Selection of explosion group

MESG	Expl. Gr. (IEC/CEN)	Gas Group (NEC)	
≥ 0,65 mm	IIB3	C	Special approvals upon request
≥ 0,5 mm	IIB	B	
□ 0,5 mm	IIC	B	

Table 3: Specification of max. operating temperature

≤ 60°C / 140°F	Tmaximum allowable operating temperature in °C	
-	Designation	higher operating temperatures upon request

Table 4: Material selection for housing

Design	B	C	
Housing	Steel	Stainless Steel	Special materials upon request
Heating jacket (SV/E-(S)-H-...)	Steel	Stainless Steel	
Valve seat	Stainless Steel	Stainless Steel	
Gasket	PTFE	PTFE	
Flame arrester unit	B	B	

Table 5: Material combinations of flame arrester unit

Design	B	
FLAMEFILTER® cage	Stainless Steel	Special materials upon request
FLAMEFILTER®	Stainless Steel	

Table 6: Material selection for valve pallet

Design	A	B	C	D	E	F
Vacuum range (mbar) (inch W.C.)	-2.0 up to -3.5 -0.8 up to -1.4	<-3.5 up to -14 <-1.4 up to -5.6	<-14 up to -35 <-5.6 up to -14	<-35 up to -60 <-14 up to -24	<-14 up to -35 <-5.6 up to -14	<-35 up to -60 <-14 up to -24
Valve pallet	Aluminium	Stainless Steel	Stainless Steel	Stainless Steel	Stainless Steel	Stainless Steel
Sealing	FEP	FEP	Metal to Metal	Metal to Metal	PTFE	PTFE

Special materials and higher pressure settings upon request

Table 7: Flange connection type

EN 1092-1; Form B1	other types upon request
ASME B16.5; 150 lbs RFSF	



for safety and environment

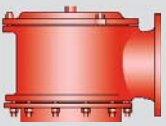

Vacuum Relief Valve

Flow Capacity Chart

PROTEGO® SV/E

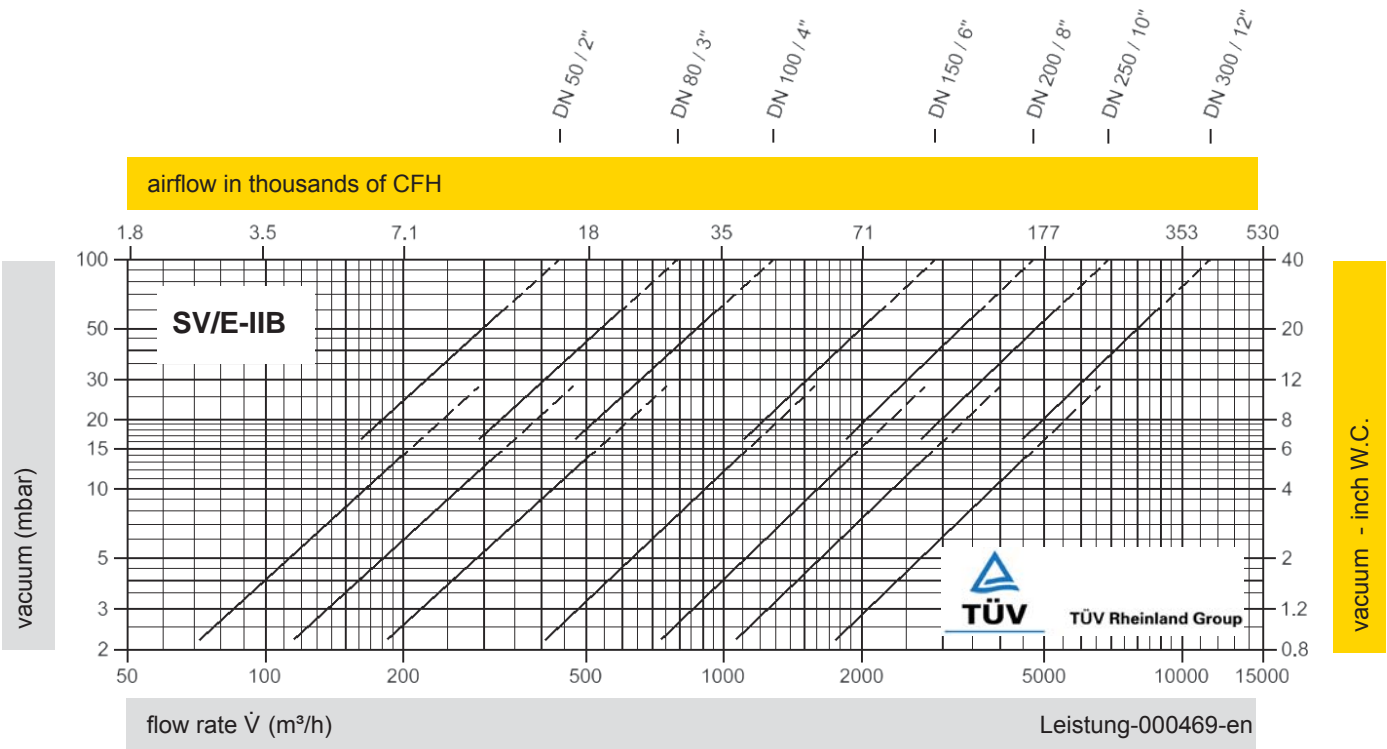
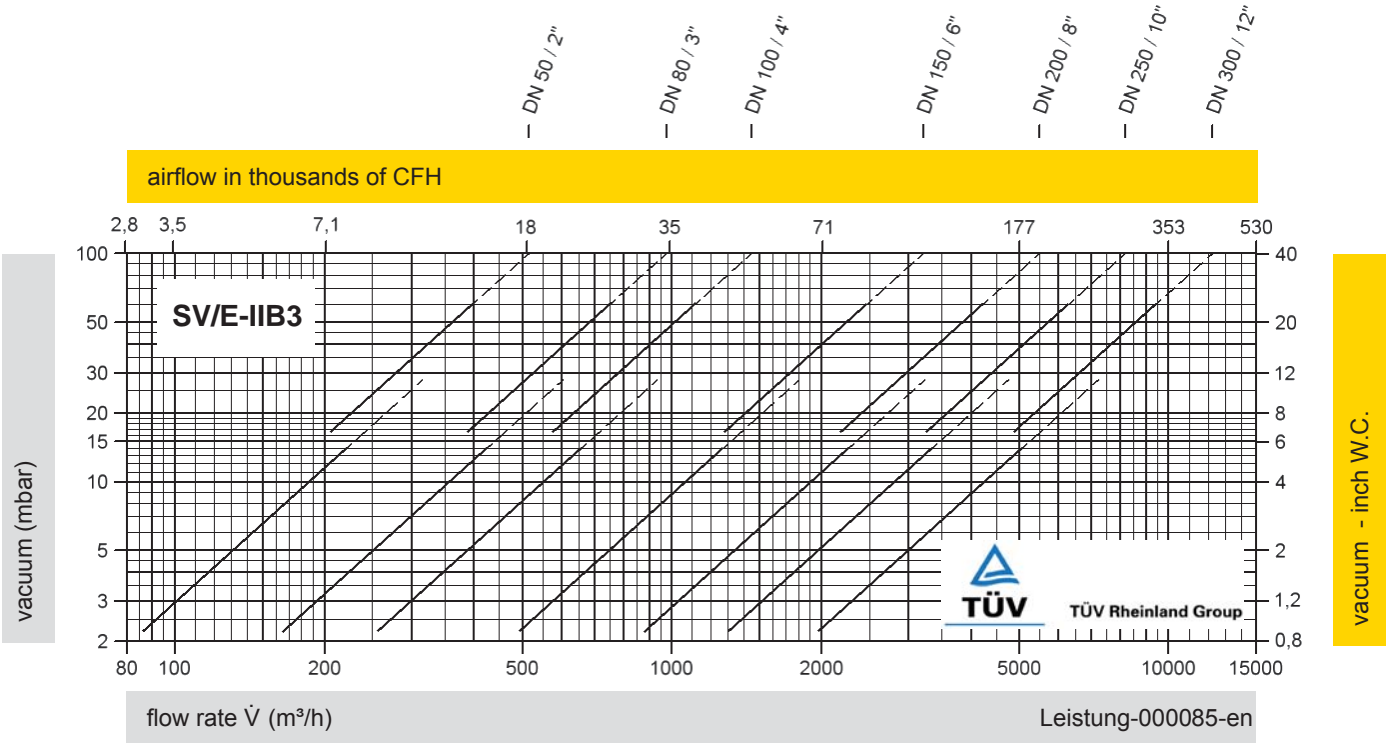

The flow capacity charts have been determined with a calibrated and TÜV certified flow capacity test rig. Volume flow \dot{V} in (m³/h) and CFH refer to the standard reference conditions of air ISO 6358 (20°C, 1bar). Conversion to other densities and temperatures refer to Vol. 1: "Technical Fundamentals".

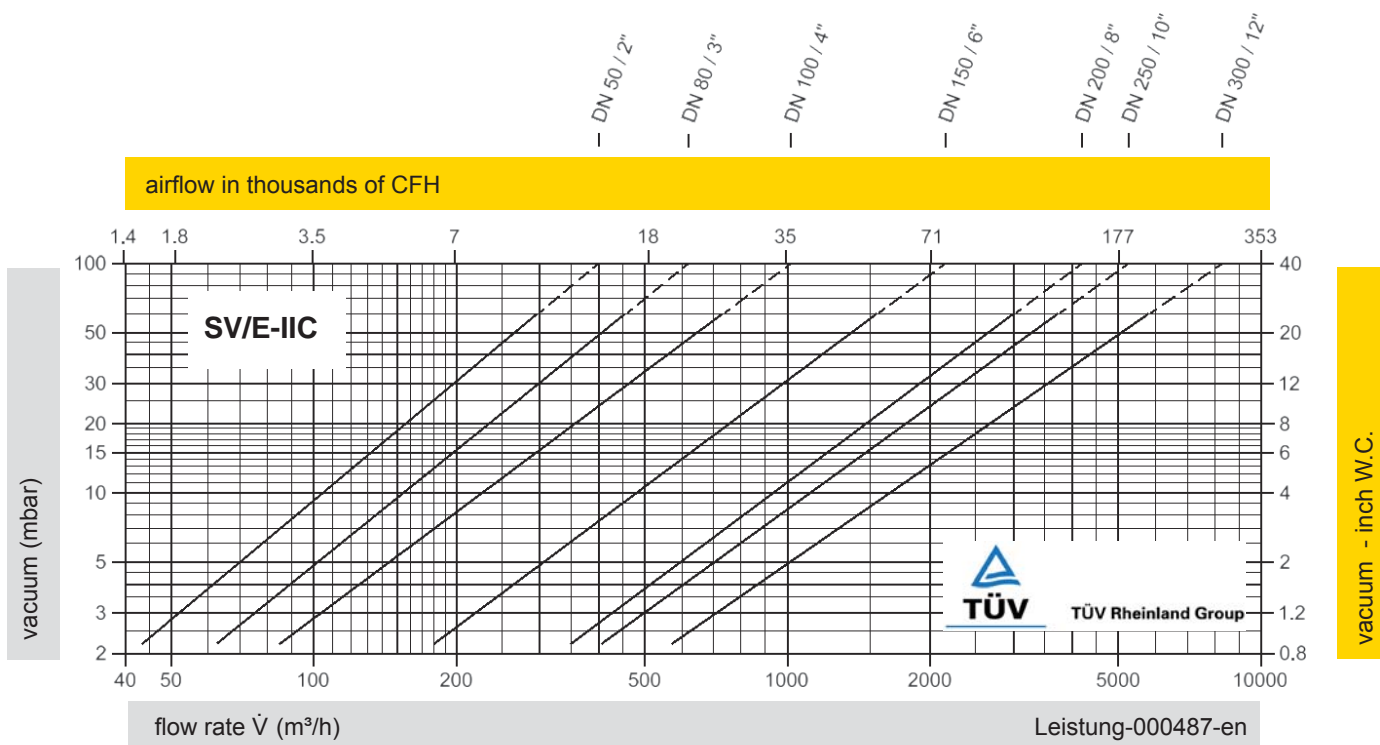

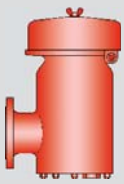

Pressure/Vacuum Relief Valve

deflagration- and endurance burning-proof



PROTEGO® PV/EB

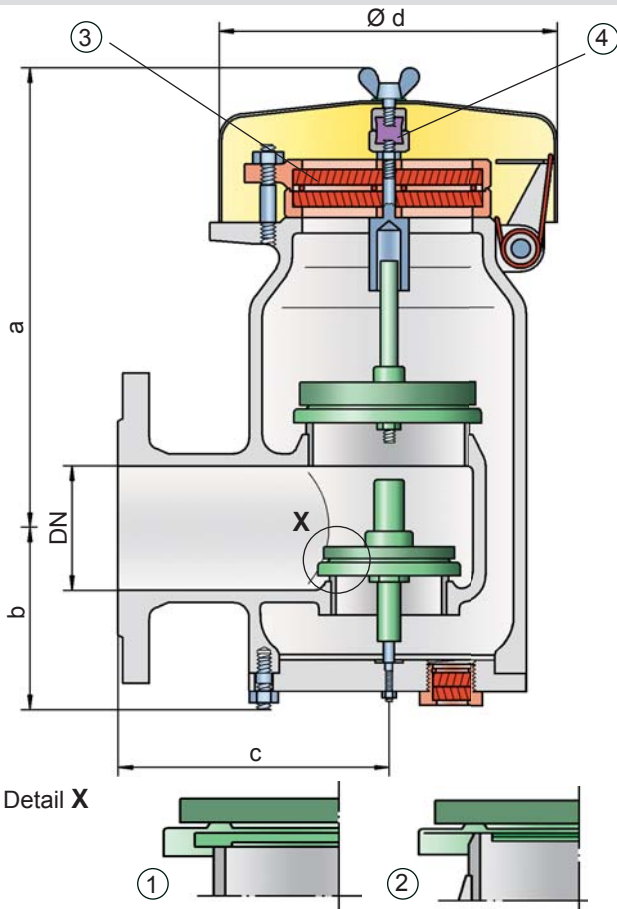

allowable working vacuum (MAWV) of the tank. After years of development, this typical opening characteristic of a safety relief valve is now also available for the low pressure range.

The tank pressure is maintained up to the set pressure with a tightness that is far superior to the conventional standard due to our state of the art manufacturing technology. This feature is ensured by the valve seats made of high quality stainless steel and with individually lapped valve pallets (1) or with an air cushion seal (2) in conjunction with high quality FEP diaphragm. The valve pallets are also available with a PTFE seal to prevent the valve pallets from sticking when sticky products are used and to enable the use of corrosive fluids. After the excess pressure is discharged, the valve reseats and provides a tight seal.

If the set pressure is exceeded, explosive gas/product-vapour air mixtures are released to the atmosphere. If this mixture ignites, the integrated PROTEGO® flame arrester unit (3) prevents flame transmission into the tank. If additional mixture continues to flow and stabilized burning occurs, the integrated flame arrester unit prevents flashback as a result from endurance burning. The valve is protected and also fulfils its function under this severe service conditions. The spring loaded weather hood opens as soon as the fusible element (4) melts.

The valve can be used up to an operating temperature of +60°C / 140°F and meets the requirements of European tank design standard EN 14015 – Appendix L and ISO 28300 (API 2000).

Type-approved in accordance with the current ATEX Directive and EN 12874 as well as other international standards.

Special Features and Advantages

- requires only 10% overpressure to full lift
- through 10% technology higher set pressures can be used which results in product loss reduction compared to conventional 40% and 100% overpressure technology vents (compare API 2000)
- increased design flexibility through higher reseating pressures; vents reseal when conventional vent is still discharging costly product or nitrogen
- high performance seal reducing product loss below EPA's 500ppm rule preventing environmental pollution
- the valve disc is guided within the housing to protect against harsh weather conditions
- can be used as protective system according ATEX in areas subject to explosion hazards
- FLAMEFILTER® provides protection against atmospheric deflagration and endurance burning
- FLAMEFILTER® integrated into the valve saves space, weight and reduces cost
- FLAMEFILTER® protected from clogging through product vapour
- PROTEGO® flame arrester unit has a low pressure drop
- flame transmission proof condensate drain
- maintenance friendly design
- special design with lifting gear can be purchased

Settings:

pressure:	+2.0 mbar	up to	+210 mbar
	+0.8 inch W.C.	up to	+84 inch W.C.
vacuum:	-14 mbar	up to	-35 mbar
	-5.6 inch W.C.	up to	-14 inch W.C.
vacuum:	-3.5 mbar	up to	-14 mbar
	-1.4 inch W.C.	up to	-5.6 inch W.C.

for pressure up to max. + 150 mbar / 60.2 inch W.C.

Higher and lower settings upon request

Function and Description

The atmospheric deflagration and endurance burning proof PV/EB type PROTEGO® valve is a highly developed combined pressure/vacuum relief valve for high flow capacities with an integrated flame arrester unit. It is primarily used as a safety device for flame transmission proof in- and outbreathing on tanks, containers and process engineering apparatus. The valve offers reliable protection against excess pressure and vacuum, prevents the inbreathing of air and product losses almost up to the set pressure and also protects against atmospheric deflagration and endurance burning if stabilized burning occurs. The PROTEGO® flame arrester unit is designed to achieve minimum pressure drop with maximum safety. The PROTEGO® PV/EB valve is available for substances of explosion group IIA (NEC group D MESG > 0.9 mm).

When the set pressure is reached, the valve starts to open and reaches full lift within 10% over pressure. This unique 10% technology enables a set pressure that is only 10% below the maximum allowable working pressure (MAWP) or maximum



Vents - 10% Technology
(Flyer pdf)



Leak Rate/10% Technology
(Flyer pdf)



Demonstration of endurance burning
Video

Design Types and Specifications

Almost any combination of vacuum and pressure levels can be set for the valve. The valve discs are weight loaded. When the difference between the pressure and vacuum exceeds 150 mbar / 60.2 inch W.C., special valve discs are used.

There are two different designs:

Pressure/vacuum relief valve, basic design **PV/EB-**

Pressure/vacuum relief valve with heating jacket **PV/EB-**
(max. heating fluid temperature +85°C / 185°F)

Additional special devices available upon request

Table 1: Dimensions

Dimensions in mm / inches

To select the nominal size (DN), please use the flow capacity charts on the following pages

DN	50 / 2"	50 / 2"	80 / 3"	80 / 3"
Set pressure	≤ +60 mbar ≤ +24.1 inch W.C.	> +60 mbar > +24.1 inch W.C.	≤ +60 mbar ≤ +24.1 inch W.C.	> +60 mbar > +24.1 inch W.C.
a	308 / 12.13	443 / 17.44	308 / 12.13	443 / 17.44
b	108 / 4.25	108 / 4.25	108 / 4.25	108 / 4.25
c	165 / 6.50	165 / 6.50	167 / 6.57	167 / 6.57
d	218 / 8.58	218 / 8.58	218 / 8.58	218 / 8.58

Dimensions for pressure/
vacuum relief valve with
heating jacket upon request

Table 2: Selection of explosion group

MESG	Expl. Gr. (IEC/CEN)	Gas Group (NEC)	Special approvals upon request
> 0,90 mm	IIA	D	

Table 3: Material selection for housing

Design	B	C	Special materials upon request
Housing	Steel	Stainless Steel	
Heating jacket (PV/EB-H-...)	Steel	Stainless Steel	
Valve seats	Stainless Steel	Stainless Steel	
Weather hood	Steel	Stainless Steel	

Table 4: Material combination of flame arrester unit

Design	A	Special materials upon request
FLAMEFILTER® cage	Stainless Steel	
FLAMEFILTER®	Stainless Steel	
Spacer	Stainless Steel	

Table 5: Material selection for pressure valve pallet

Design	A	B	C	D	Special material as well as higher set pressure upon request
Pressure range (mbar) (inch W.C.)	+2.0 up to +3.5 +0.8 up to +1.4	>+3.5 up to +14 >+1.4 up to +5.6	>+14 up to +210 >+5.6 up to +84	>+35 up to +210 >+14 up to +84	
Valve pallet	Aluminium	Stainless Steel	Stainless Steel	Stainless Steel	
Sealing	FEP	FEP	Metal to Metal	PTFE	

Table 6: Material selection for vacuum pallet

Design	A	B	C	D	Special material as well as higher set vacuum upon request
Vacuum range (mbar) (inch W.C.)	-3.5 up to -5.0 -1.4 up to -2.0	<-5.0 up to -14 <-2.0 up to -5.6	<-14 up to -35 <-5.6 up to -14	<-14 up to -35 <-5.6 up to -14	
Valve pallet	Aluminium	Stainless Steel	Stainless Steel	Stainless Steel	
Sealing	FEP	FEP	Metal to Metal	PTFE	

Table 7: Flange connection type

EN 1092-1; Form B1	other types upon request
ASME B16.5; 150 lbs RFSF	



for safety and environment

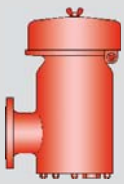

Pressure/Vacuum Relief Valve

Flow Capacity Charts

PROTEGO® PV/EB

airflow in thousands of CFH

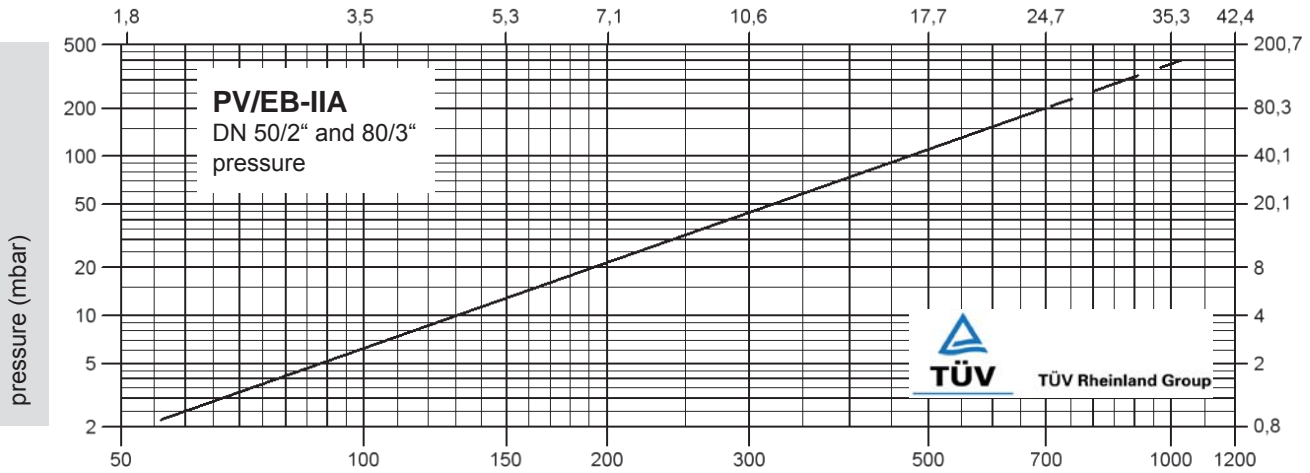

flow rate \dot{V} (m³/h)

2297-L

airflow in thousands of CFH

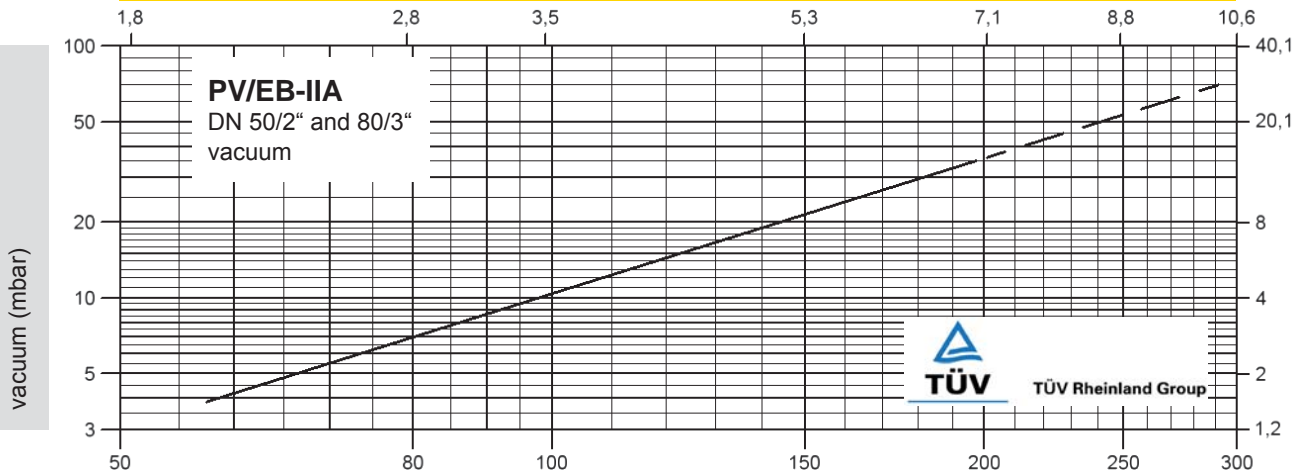

flow rate \dot{V} (m³/h)

2298-L

The flow capacity charts have been determined with a calibrated and TÜV certified flow capacity test rig. Volume flow \dot{V} in (m³/h) and CFH refer to the standard reference conditions of air ISO 6358 (20°C, 1bar). Conversion to other densities and temperatures refer to Vol. 1: "Technical Fundamentals".

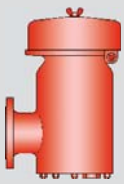

Pressure/Vacuum Relief Valve

deflagration- and endurance burning-proof



PROTEGO® PV/EB-E

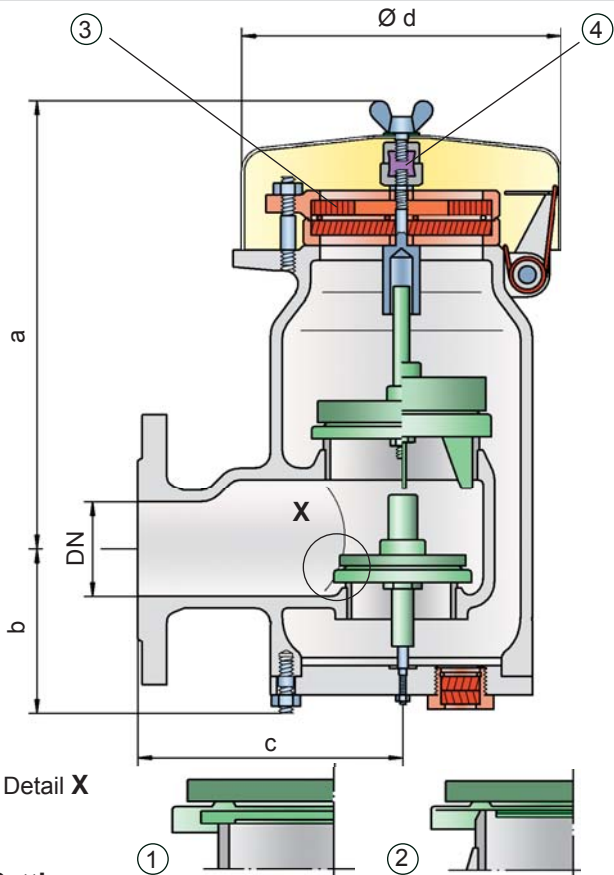

Settings:

pressure:	+2.0 mbar	up to	+210 mbar
	+0.8 inch W.C.	up to	+84 inch W.C.
vacuum:	-14 mbar	up to	-35 mbar
	-5.6 inch W.C.	up to	-14 inch W.C.
vacuum:	-3.5 mbar	up to	-14 mbar
	-1.4 inch W.C.	up to	-5.6 inch W.C.

for pressure up to max. + 150 mbar / 60.2 inch W.C.

Higher and lower settings upon request

Function and Description

The deflagration-proof and endurance burning-proof PV/EB-E type PROTEGO® valve is a highly developed combined pressure/vacuum relief valve for high flow capacities with an integrated flame arrester unit that is specially used for applications handling ethanol. It is primarily used as a safety device for flame transmission proof in- and outbreathing on tanks, containers and process engineering apparatus. The valve offers reliable protection against excess pressure and vacuum, prevents the inbreathing of air and product losses almost up to the set pressure and also protects against atmospheric deflagration as well as endurance burning if stabilized burning occurs. The PROTEGO® flame arrester unit is designed to achieve minimum pressure drop with maximum safety. The PROTEGO® PV/EB-E valve is available for substances of explosion group IIB1 (MESG ≥ 0.85 mm) and provides specific protection against deflagration and endurance burning of alcohol/air mixtures (such as ethanol/air).

The valve functions proportionally, so the set pressures should be selected in relation to the proportional behaviour (such as a 10%, 40%, or 100% overpressure from the set pressure to the relieving pressure at which the required flow performance is reached).

The tank pressure is maintained up to the set pressure with a tightness that is far superior to the conventional standard due to our state of the art manufacturing technology. This feature is ensured by the valve seats made of high quality stainless steel and with individually lapped valve pallets (1) or with an air cushion seal (2) in conjunction with high quality FEP diaphragm. The valve pallets are also available with a PTFE seal to prevent the valve pallets from sticking when sticky products are used and to enable the use of corrosive fluids. After the excess pressure is discharged, the valve reseats and provides a tight seal.

If the set pressure is exceeded, gas/product-vapour air mixtures are released to the atmosphere. If this mixture ignites, the integrated PROTEGO® flame arrester unit (3) prevents flame transmission into the tank. If additional mixture continues to flow and stabilized burning occurs, the integrated flame arrester unit prevents flashback as a result from endurance burning. The valve is protected and also fulfils its function under this severe service conditions. The spring loaded weather hood opens as soon as the fusible element (4) melts.

The valve can be used up to an operating temperature of +60°C / 140°F and meets the requirements of European tank design standard EN 14015 – Appendix L and ISO 28300 (API 2000).

Type-approved in accordance with the current ATEX Directive and EN ISO 16852 as well as other international standards.

Special Features and Advantages

- selecting set pressure close to relieving pressure results in product loss reduction
- increased design flexibility through higher reseating pressures; vents reseal when conventional vent is still discharging costly product or nitrogen
- the valve disc is guided within the housing to protect against harsh weather conditions
- high performance seal reducing product loss below EPA's 500ppm rule preventing environmental pollution
- can be used as protective system according to ATEX in areas subject to explosion hazards
- safe against deflagration and endurance burning of alcohol/air mixtures from explosion group IIB1
- high flow capacity through large FLAMEFILTER® cross-section, results in low pressure drop
- FLAMEFILTER® provides protection against atmospheric deflagration and endurance burning
- FLAMEFILTER® integrated into the valve saves space, weight and reduces cost
- FLAMEFILTER® protected from clogging caused by product vapours
- flame transmission proof condensate drain
- maintenance friendly design
- modular design enables individual FLAMEFILTER® and valve pallets to be replaced
- special design with lifting gear can be purchased



Demonstration of endurance burning
Video

Design Types and Specifications

Almost any combination of vacuum and pressure levels can be set for the valve. The valve discs are weight loaded. When the difference between the pressure and vacuum exceeds 150 mbar / 60.2 inch W.C., special valve discs are used.

There are two different designs:

Pressure/vacuum relief valve, basic design **PV/EB-E-**

Pressure/vacuum relief valve with heating jacket **PV/EB-E-H**
(max. heating fluid temperature +85°C / 185°F)

Additional special devices available upon request

Table 1: Dimensions

Dimensions in mm / inches

To select the nominal size (DN), please use the flow capacity charts on the following pages

DN	50 / 2"	50 / 2"	80 / 3"	80 / 3"
Set pressure	≤ +60 mbar ≤ +24.1 inch W.C.	> +60 mbar ≤ +24.1 inch W.C.	≤ +60 mbar ≤ +24.1 inch W.C.	> +60 mbar ≤ +24.1 inch W.C.
a	308 / 12.13	443 / 17.44	308 / 12.13	443 / 17.44
b	108 / 4.25	108 / 4.25	108 / 4.25	108 / 4.25
c	165 / 6.50	165 / 6.50	167 / 6.57	167 / 6.57
d	218 / 8.58	218 / 8.58	218 / 8.58	218 / 8.58

Dimensions for Pressure/
Vacuum Relief Valve with
heating jacket upon request

Table 2: Selection of explosion group

MESG	Expl. Gr. (IEC/CEN)	Gas Group (NEC)	
≥ 0,85 mm	IIB1	–	Special approvals upon request

Table 3: Material selection for housing

Design	B	C	
Housing	Steel	Stainless Steel	Special materials upon request
Heating jacket (PV/EB-E-H-...)	Steel	Stainless Steel	
Valve seats	Stainless Steel	Stainless Steel	
Weather hood	Steel	Stainless Steel	

Table 4: Material combination of flame arrester unit

Design	A	
FLAMEFILTER® cage	Stainless Steel	Special materials upon request
FLAMEFILTER®	Stainless Steel	
Spacer	Stainless Steel	

Table 5: Material selection for pressure valve pallet

Design	A	B	C	D	
Pressure range (mbar) (inch W.C.)	+2.0 up to +3.5 +0.8 up to +1.4	>+3.5 up to +14 >+1.4 up to +5.6	>+14 up to +210 >+5.6 up to +84	>+35 up to +210 >+14 up to +84	Special material as well as higher set pressure upon request
Valve pallet	Aluminium	Stainless Steel	Stainless Steel	Stainless Steel	
Sealing	FEP	FEP	Metal to Metal	PTFE	

Table 6: Material selection for vacuum pallet

Design	A	B	C	D	
Vacuum range (mbar) (inch W.C.)	-3.5 up to -5.0 -1.4 up to -2.0	<-5.0 up to -14 <-2.0 up to -5.6	<-14 up to -35 <-5.6 up to -14	<-14 up to -35 <-5.6 up to -14	Special material as well as higher set vacuum upon request
Valve pallet	Aluminium	Stainless Steel	Stainless Steel	Stainless Steel	
Sealing	FEP	FEP	Metal to Metal	PTFE	

Table 7: Flange connection type

EN 1092-1; Form B1	other types upon request
ASME B16.5; 150 lbs RFSF	



for safety and environment

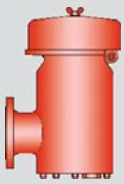

Pressure/Vacuum Relief Valve

Flow Capacity Charts

PROTEGO® PV/EB-E

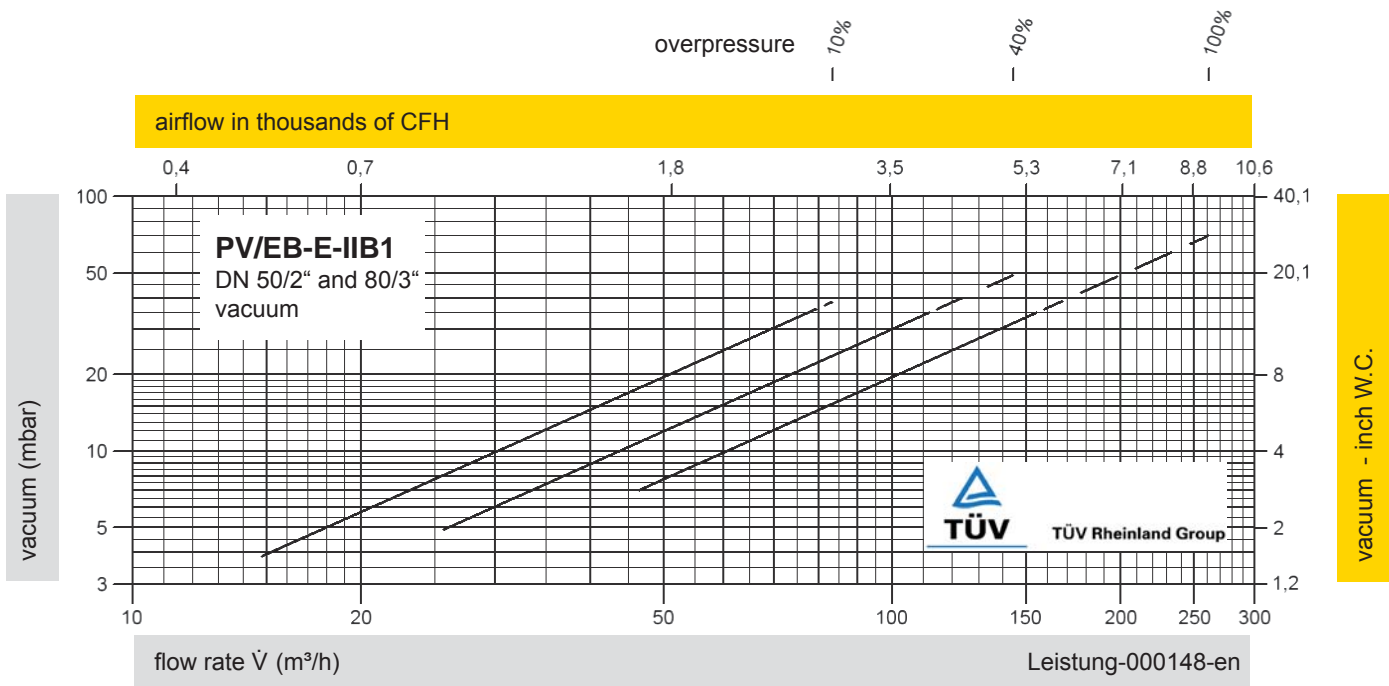
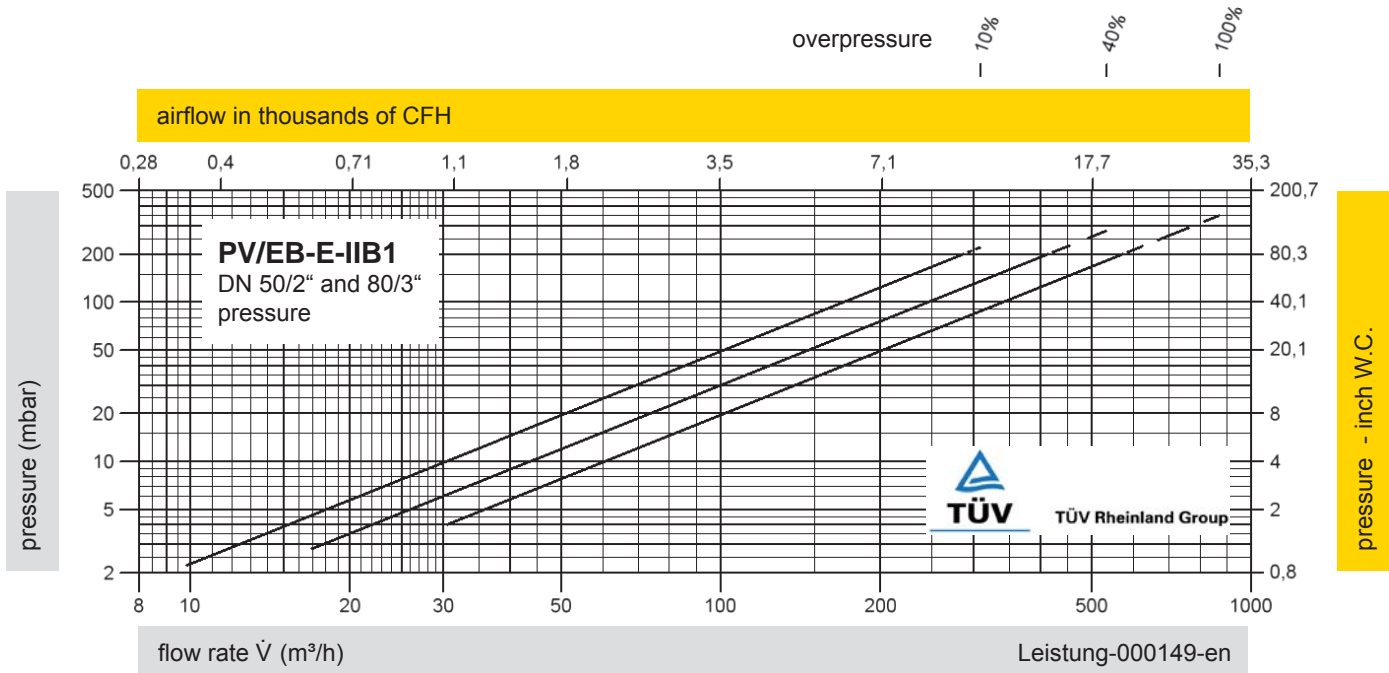

Remark

$$\text{set pressure} = \frac{\text{opening pressure resp. tank design pressure}}{1 + \frac{\text{overpressure \%}}{100\%}}$$

Set pressure = the valve starts to open

Opening pressure = set pressure plus overpressure

Overpressure % = percentage pressure increase over the set pressure

The flow capacity charts have been determined with a calibrated and TÜV certified flow capacity test rig. Volume flow \dot{V} in (m³/h) and CFH refer to the standard reference conditions of air ISO 6358 (20°C, 1bar). Conversion to other densities and temperatures refer to Vol. 1: "Technical Fundamentals".

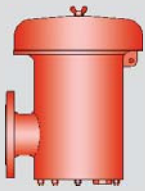

Pressure/Vacuum Relief Valve

deflagration- and endurance burning-proof



PROTEGO® PV/EBR

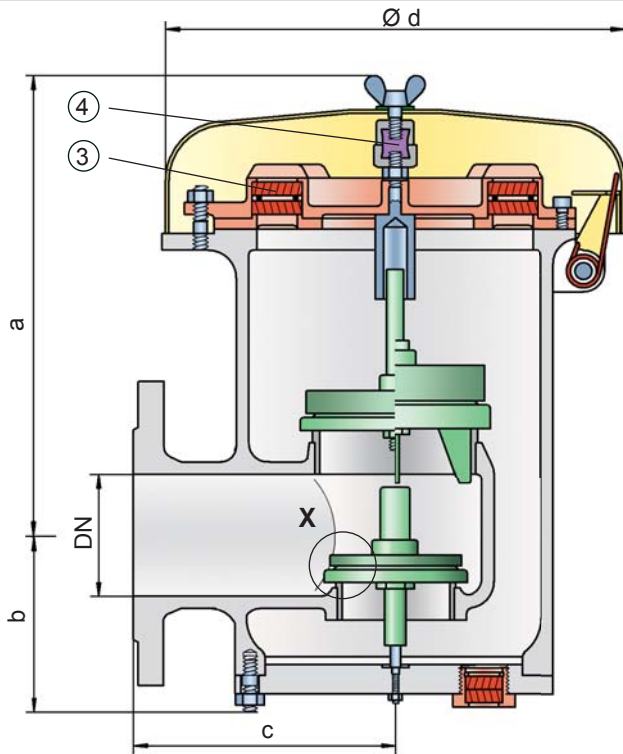

Detail X

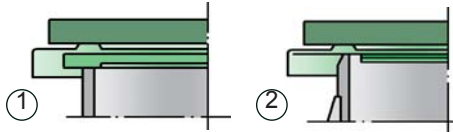

Settings:

pressure:	+2.0 mbar	up to	+210 mbar
	+0.8 inch W.C.	up to	+84 inch W.C.
vacuum:	-14 mbar	up to	-50 mbar
	-5.6 inch W.C.	up to	-20 inch W.C.
vacuum:	-3.5 mbar	up to	-14 mbar
	-1.4 inch W.C.	up to	-5.6 inch W.C.

for pressure up to max. + 150 mbar / 60.2 inch W.C.
Higher and lower settings upon request

Function and Description

The deflagration-proof and endurance burning-proof PV/EBR type PROTEGO® valve is a highly developed combined pressure/vacuum relief valve for high flow capacities with an integrated flame arrester. It is primarily used as a safety device for flame transmission proof in- and outbreathing on tanks, containers and process engineering apparatus. The valve offers reliable protection against excess pressure and vacuum, prevents the inbreathing of air and product losses almost up to the set pressure and also protects against atmospheric deflagration as well as endurance burning if stabilized burning occurs. The PROTEGO® flame arrester unit is designed to achieve minimum pressure drop with maximum safety. PROTEGO® PV/EBR valves are available for substances from explosion groups IIA to IIB3 (NEC group D to C MESH ≥ 0.65 mm).

The valve functions proportional, so the set pressures should be selected in relation to the proportional behaviour (such as a 10%, 40%, or 100% overpressure from the set pressure to the relieving pressure at which the required flow performance is reached).

The tank pressure is maintained up to the set pressure with a tightness that is far superior to the conventional standard due to our state of the art manufacturing technology. This feature is ensured by the valve seats made of high quality stainless steel and with individually lapped valve pallets (1) or with an air cushion seal (2) in conjunction with high quality FEP diaphragm. The valve pallets are also available with a PTFE seal to prevent the valve pallets from sticking when sticky products are used and to enable the use of corrosive fluids. After the excess pressure is discharged, the valve reseats and provides a tight seal.

If the set pressure is exceeded, explosive gas/product-vapour air mixtures are released to the atmosphere. If this mixture ignites, the integrated PROTEGO® flame arrester unit (3) prevents flame transmission into the tank. If additional mixture continues to flow and stabilized burning occurs, the integrated flame arrester unit prevents flashback as a result from endurance burning. The valve is protected and also fulfils its function under this severe service conditions. The spring loaded weather hood opens as soon as the fusible element (4) melts.

The valve can be used up to an operating temperature of +60°C / 140°F and meets the requirements of European tank design standard EN 14015 – Appendix L and ISO 28300 (API 2000).

Type-approved in accordance with the current ATEX Directive as well as other international standards.

Special Features and Advantages

- selecting set pressure close to relieving pressure results in product loss reduction
- more design flexibility through higher reseating pressures; vents reseal when conventional vent is still discharging costly product or nitrogen
- the valve disc is guided within the housing to protect against harsh weather conditions
- high performance seal reducing product loss below EPA's 500ppm rule preventing environmental pollution
- can be used as protective system according to ATEX in areas subject to explosion hazards
- high flow capacity through large FLAMEFILTER® cross-section, results in low pressure drop
- FLAMEFILTER® provides protection against atmospheric deflagration and endurance burning
- FLAMEFILTER® integrated into the valve saves space, weight and reduces cost
- FLAMEFILTER® protected from clogging caused by product vapours
- flame transmission proof condensate drain
- maintenance friendly design
- modular design enables individual FLAMEFILTER® and valve pallets to be replaced
- special design with lifting gear can be purchased



Design Types and Specifications

Almost any combination of vacuum and pressure levels can be set for the valve. The valve discs are weight loaded. When the difference between the pressure and vacuum exceeds 150 mbar / 60.2 inch W.C., special valve discs are used.

There are two different designs:

- Pressure/vacuum relief valve, basic design **PV/EBR-**
 - Pressure /vacuum relief valve with heating jacket **PV/EBR-** **H**
(max. heating fluid temperature +85°C / 185°F)
- Additional special devices available upon request

Table 1: Dimensions

Dimensions in mm / inches

To select the nominal size (DN), please use the flow capacity charts on the following pages

DN	80 / 3"	80 / 3"	100 / 4"	100 / 4"	Dimensions for pressure/ vacuum relief valve with heating jacket upon request
Set pressure	≤ +35 mbar ≤ +14 inch W.C.	> +35 mbar > +14 inch W.C.	≤ +35 mbar ≤ +14 inch W.C.	> +35 mbar > +14 inch W.C.	
a	345 / 13.58	475 / 18.70	345 / 13.58	475 / 18.70	
b	141 / 5.55	141 / 5.55	141 / 5.55	141 / 5.55	
c	218 / 8.58	218 / 8.58	218 / 8.58	218 / 8.58	
d	353 / 13.90	353 / 13.90	353 / 13.90	353 / 13.90	

Table 2: Selection of explosion group

MESG	Expl. Gr. (IEC/CEN)	Gas Group (NEC)	Special approvals upon request
> 0,90 mm	IIA	D	
≥ 0,65 mm	IIB3	C	

Table 3: Material selection for housing

Design	B	C	Special materials upon request
Housing	Steel	Stainless Steel	
Heating jacket (PV/EBR-H-...)	Steel	Stainless Steel	
Valve seats	Stainless Steel	Stainless Steel	
Weather hood	Steel	Stainless Steel	

Table 4: Material combination of flame arrester unit

Design	A	Special materials upon request
FLAMEFILTER® cage	Stainless Steel	
FLAMEFILTER®	Stainless Steel	
Spacer	Stainless Steel	

Table 5: Material selection for pressure valve pallet

Design	A	B	C	D	Special material as well as higher set pressure upon request
Pressure range (mbar) (inch W.C.)	+2.0 up to +3.5 +0.8 up to +1.4	>+3.5 up to +14 >+1.4 up to +5.6	>+14 up to +210 >+5.6 up to +84	>+35 up to +210 >+14 up to +84	
Valve pallet	Aluminium	Stainless Steel	Stainless Steel	Stainless Steel	
Sealing	FEP	FEP	Metal to Metal	PTFE	

Table 6: Material selection for vacuum pallet

Design	A	B	C	D	Special material as well as higher set vacuum upon request
Vacuum range (mbar) (inch W.C.)	-3.5 up to -5.0 -1.4 up to -2.0	<-5.0 up to -14 <-2.0 up to -5.6	<-14 up to -50 <-5.6 up to -20	<-14 up to -50 <-5.6 up to -20	
Valve pallet	Aluminium	Stainless Steel	Stainless Steel	Stainless Steel	
Sealing	FEP	FEP	Metal to Metal	PTFE	

Table 7: Flange connection type

EN 1092-1; Form B1	other types upon request
ASME B16.5; 150 lbs RF5F	



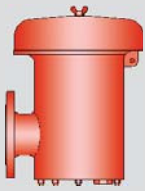

Pressure/Vacuum Relief Valve

Flow Capacity Charts

PROTEGO® PV/EBR

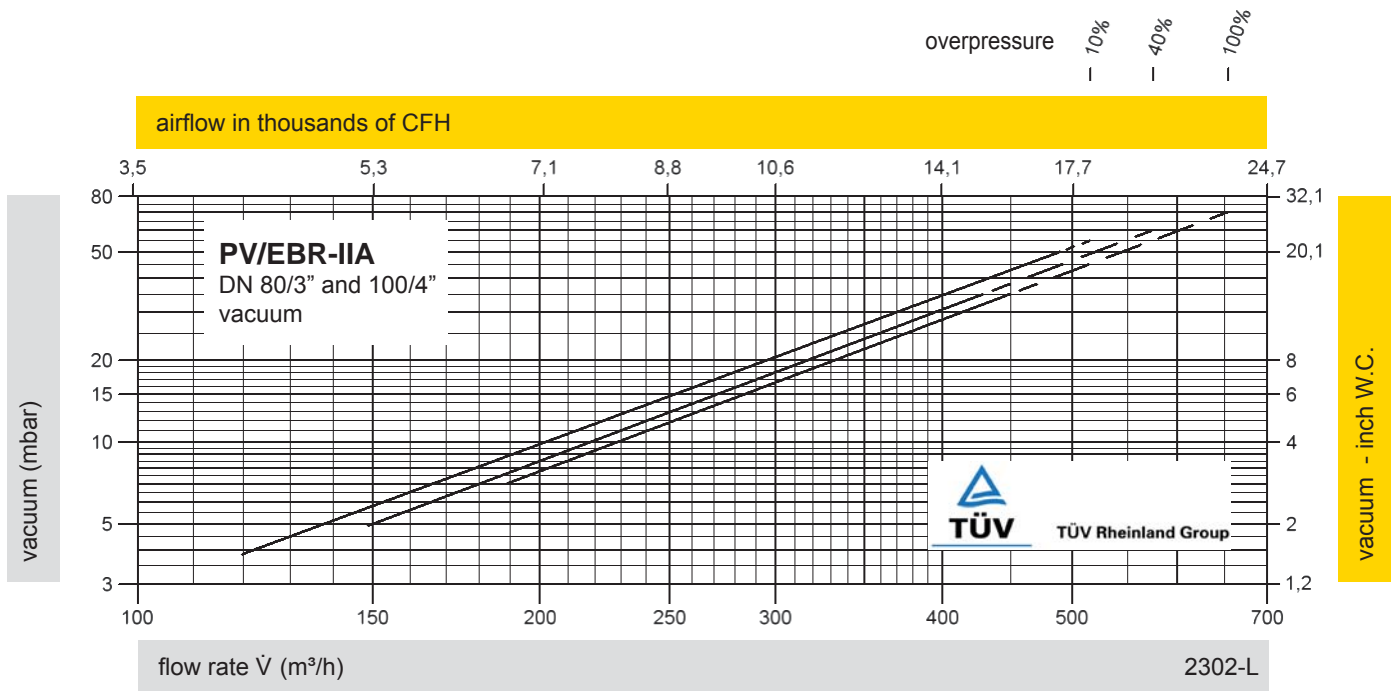
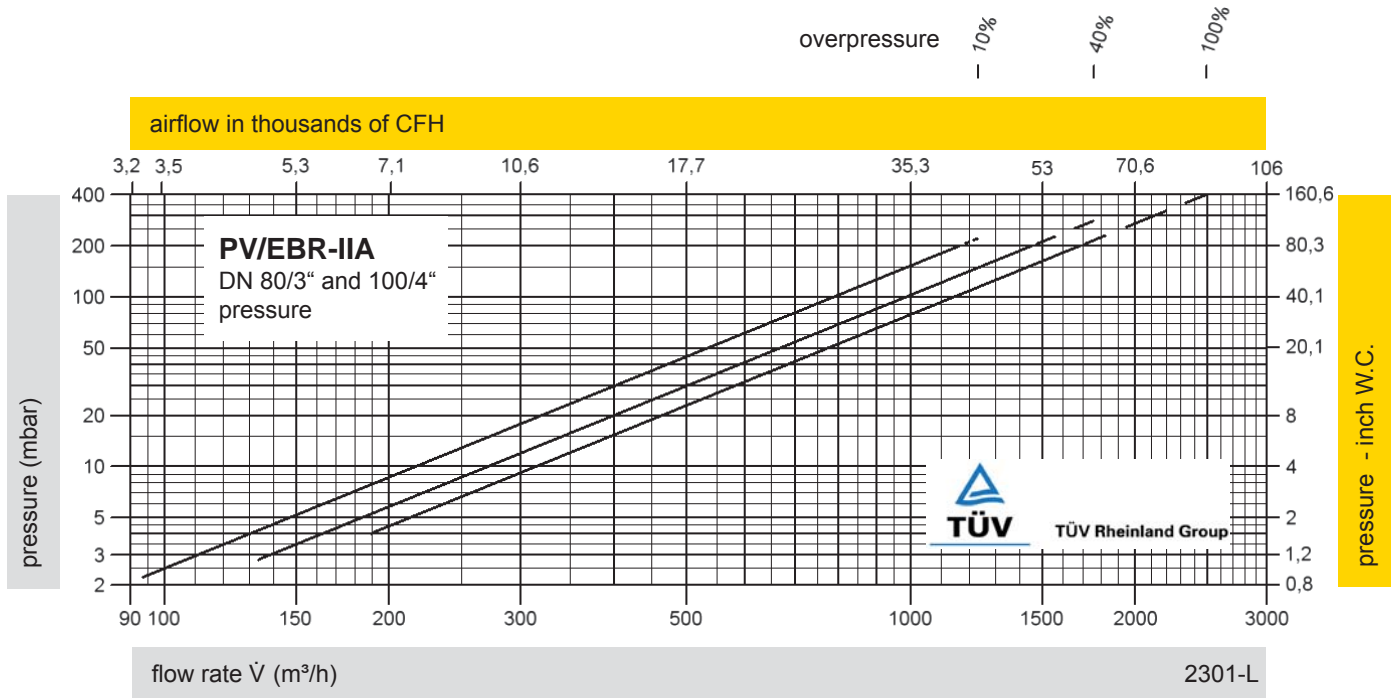

Remark

$$\text{set pressure} = \frac{\text{opening pressure resp. tank design pressure}}{1 + \frac{\text{overpressure \%}}{100\%}}$$

Set pressure = the valve starts to open

Opening pressure = set pressure plus overpressure

Overpressure % = percentage pressure increase over the set pressure

The flow capacity charts have been determined with a calibrated and TÜV certified flow capacity test rig. Volume flow \dot{V} in (m³/h) and CFH refer to the standard reference conditions of air ISO 6358 (20°C, 1bar). Conversion to other densities and temperatures refer to Vol. 1: "Technical Fundamentals".

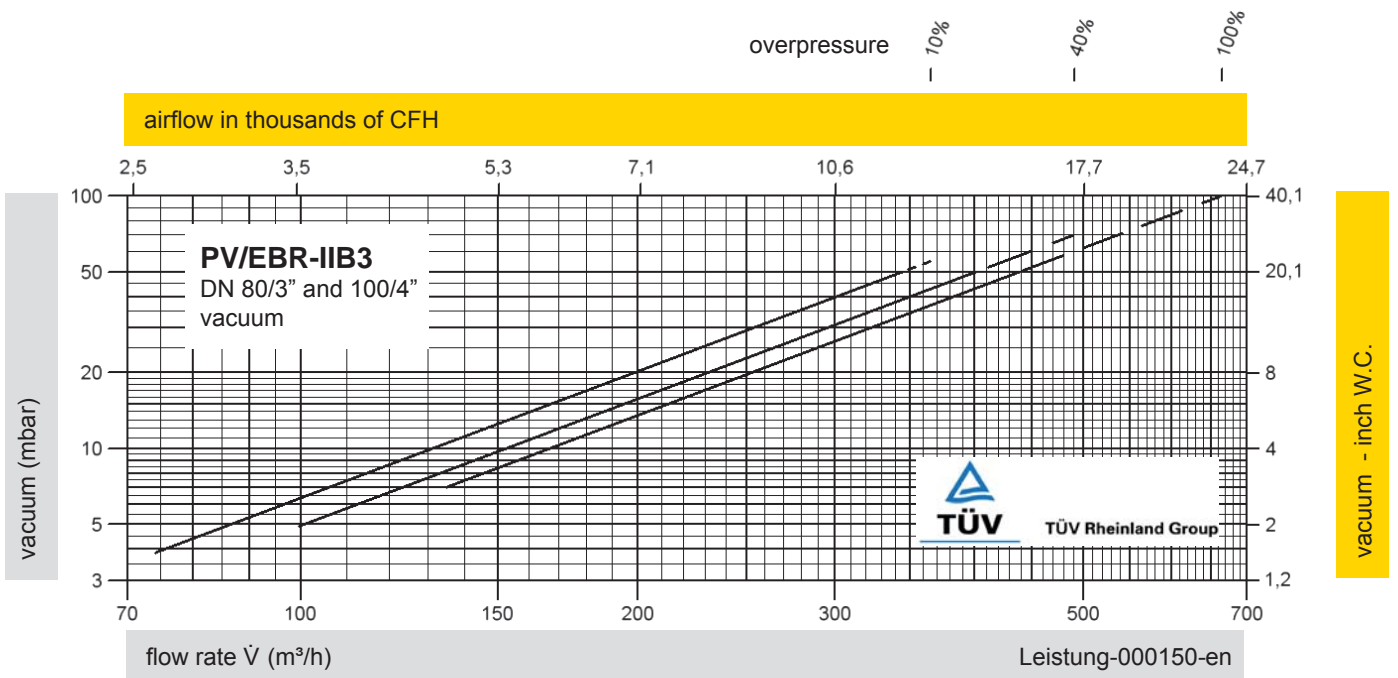
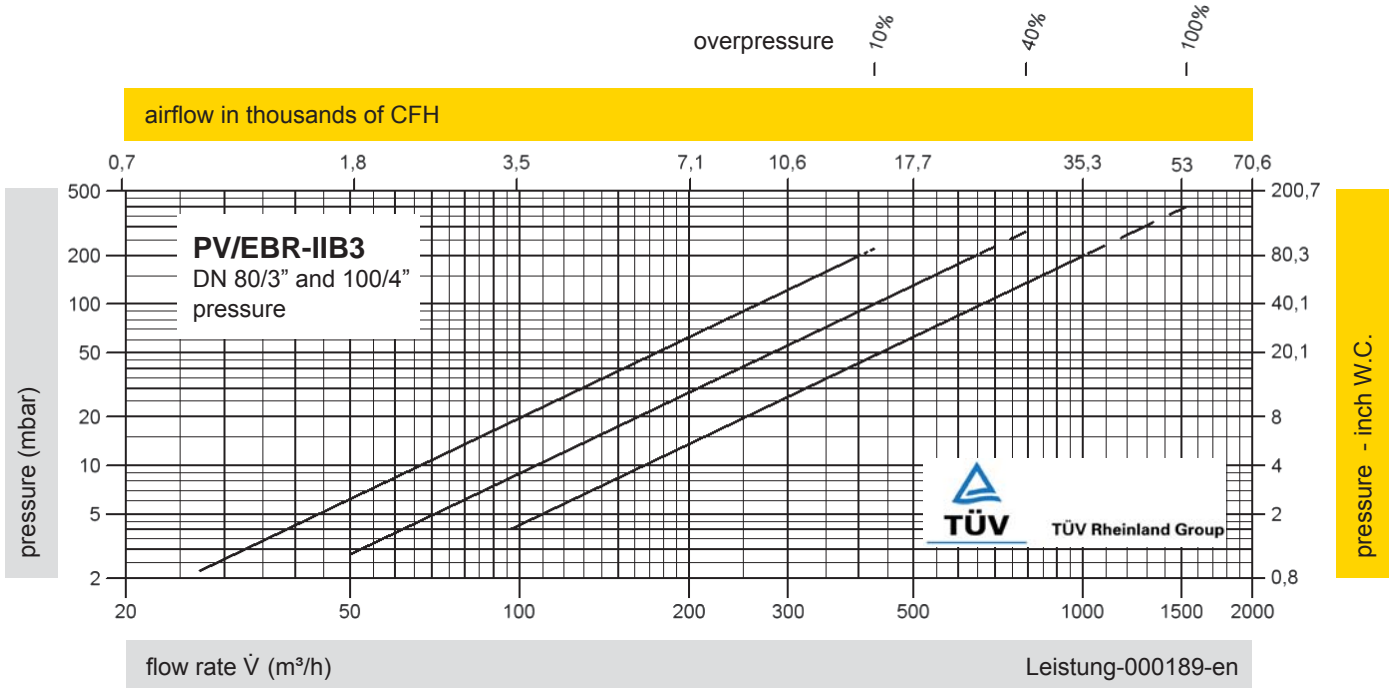

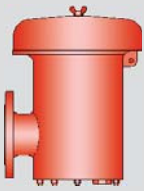

Pressure/Vacuum Relief Valve deflagration- and endurance burning-proof

PROTEGO® PV/EBR-E

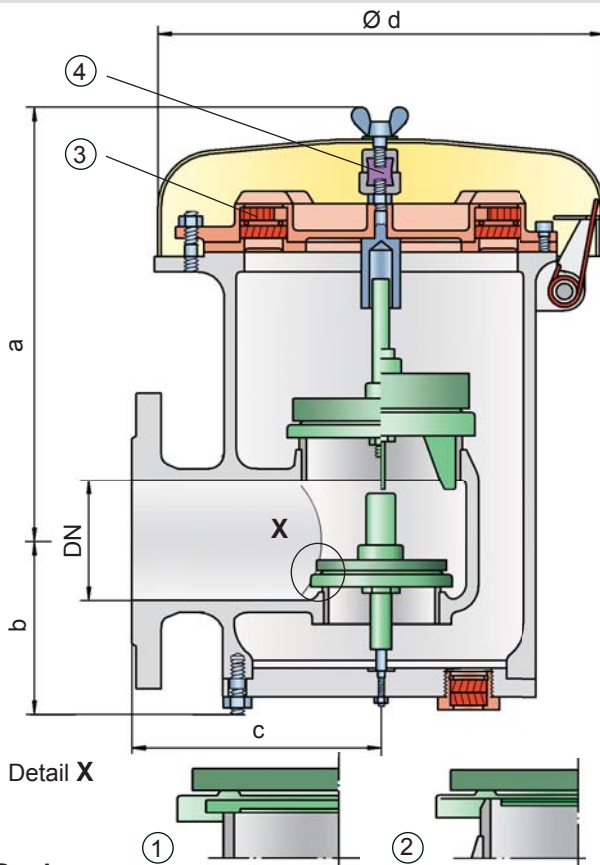

Settings:

pressure:	+2.0 mbar	up to	+210 mbar
	+0.8 inch W.C.	up to	+84 inch W.C.
vacuum:	-14 mbar	up to	-50 mbar
	-5.6 inch W.C.	up to	-20 inch W.C.
vacuum:	-3.5 mbar	up to	-14 mbar
	-1.4 inch W.C.	up to	-5.6 inch W.C.

for pressure up to max. + 150 mbar / 60.2 inch W.C.
Higher and lower settings upon request

Function and Description

The deflagration-proof and endurance burning-proof PV/EBR-E type PROTEGO® valve is a highly developed combined pressure/vacuum relief valve for high flow capacities with an integrated flame arrester that is specially used for applications handling ethanol. It is primarily used as a safety device for flame transmission proof outbreathing on tanks, containers and process engineering apparatus. The valve offers reliable protection against excess pressure and vacuum, prevents the inbreathing of air and product losses almost up to the set pressure and also protects against atmospheric deflagration as well as endurance burning if stabilized burning occurs. The PROTEGO® flame arrester unit is designed to achieve minimum pressure drop with maximum safety. The PROTEGO® PV/EBR-E valve is available for substances of explosion group IIB1 (MESG ≥ 0.85 mm) and provides specific protection against deflagration and endurance burning of alcohol/air mixtures (such as ethanol/air).

The valve functions proportional, so the set pressures should be selected in relation to the proportional behaviour (such as a 10%, 40%, or 100% overpressure from the set pressure to the relieving pressure at which the required flow performance is reached).

The tank pressure is maintained up to the set pressure with a tightness that is far superior to the conventional standard due to our state of the art manufacturing technology. This feature is ensured by the valve seats made of high quality stainless steel and with individually lapped valve pallets (1) or with an air cushion seal (2) in conjunction with high quality FEP diaphragm. The valve pallets are also available with a PTFE seal to prevent the valve pallets from sticking when sticky products are used and to enable the use corrosive fluids. After the excess pressure is discharged, the valve reseats and provides a tight seal.

If the set pressure is exceeded, explosive gas/product-vapour air mixtures are released to the atmosphere. If this mixture ignites, the integrated PROTEGO® flame arrester unit (3) prevents flame transmission into the tank. If additional mixture continues to flow and stabilized burning occurs, the integrated flame arrester unit prevents flashback as a result from endurance burning. The valve is protected and also fulfils its function under this severe service conditions. The spring loaded weather hood opens as soon as the fusible element (4) melts.

The valve can be used up to an operating temperature of +60°C / 140°F and meets the requirements of European tank design standard EN 14015 – Appendix L and ISO 28300 (API 2000).

Type-approved in accordance with the current ATEX Directive and EN ISO 16852 as well as other international standards.

Special Features and Advantages

- selecting set pressure close to relieving pressure results in product loss reduction
- more design flexibility through higher reseating pressures; vents reseal when conventional vent is still discharging costly product or nitrogen
- the valve disc is guided within the housing to protect against harsh weather conditions
- high performance seal reducing product loss below EPA's 500ppm rule preventing environmental pollution
- can be used as protective system according to ATEX in areas subject to explosion hazards
- safe against deflagration and endurance burning of alcohol/air mixtures and for substances of explosion group IIB1
- high flow capacity through large flame filter cross-section, results in low pressure drop
- FLAMEFILTER® provides protection against atmospheric deflagration and endurance burning
- FLAMEFILTER® integrated into the valve saves space, weight and reduces cost
- FLAMEFILTER® protected from clogging caused by product vapours
- flame transmission proof condensate drain
- maintenance friendly design
- modular design enables individual FLAMEFILTER® and valve pallets to be replaced
- special design with lifting gear can be purchased



Demonstration of endurance burning
Video

Design Types and Specifications

Almost any combination of vacuum and pressure levels can be set for the valve. The valve discs are weight loaded. When the difference between the pressure and vacuum exceeds 150 mbar / 60.2 inch W.C., special valve discs are used.

There are two different designs:

Pressure/vacuum relief valve, basic design

PV/EBR-E-

Pressure/vacuum relief valve with heating jacket (max. heating fluid temperature

PV/EBR-E-

+85°C / 185°F)

Additional special devices available upon request

Table 1: Dimensions

Dimensions in mm / inches

To select the nominal size (DN), please use the flow capacity charts on the following pages

DN	80 / 3"	80 / 3"	100 / 4"	100 / 4"	Dimensions for Pressure/ Vacuum Relief Valve with heating jacket upon request
Set pressure	≤ +35 mbar ≤ +14 inch W.C.	> +35 mbar > +14 inch W.C.	≤ +35 mbar ≤ +14 inch W.C.	> +35 mbar > +14 inch W.C.	
a	345 / 13.58	475 / 18.70	345 / 13.58	475 / 18.70	
b	141 / 5.55	141 / 5.55	141 / 5.55	141 / 5.55	
c	218 / 8.58	218 / 8.58	218 / 8.58	218 / 8.58	
d	353 / 13.90	353 / 13.90	353 / 13.90	353 / 13.90	

Table 2: Selection of explosion group

MESG	Expl. Gr. (IEC/CEN)	Gas Group (NEC)	Special approvals upon request
≥ 0,85 mm	IIB1	–	

Table 3: Material selection for housing

Design	B	C	Special materials upon request
Housing	Steel	Stainless Steel	
Heating jacket (PV/EBR-E-H-...)	Steel	Stainless Steel	
Valve seats	Stainless Steel	Stainless Steel	
Weather hood	Steel	Stainless Steel	

Table 4: Material combination of flame arrester unit

Design	A	Special materials upon request
FLAMEFILTER® cage	Stainless Steel	
FLAMEFILTER®	Stainless Steel	
Spacer	Stainless Steel	

Table 5: Material selection for pressure valve pallet

Design	A	B	C	D	Special material as well as higher set pressure upon request
Pressure range (mbar) (inch W.C.)	+2.0 up to +3.5 +0.8 up to +1.4	>+3.5 up to +14 >+1.4 up to +5.6	>+14 up to +210 >+5.6 up to +84	>+35 up to +210 >+14 up to +84	
Valve pallet	Aluminium	Stainless Steel	Stainless Steel	Stainless Steel	
Sealing	FEP	FEP	Metal to Metal	PTFE	

Table 6: Material selection for vacuum pallet

Design	A	B	C	D	Special material as well as higher set vacuum upon request
Vacuum range (mbar) (inch W.C.)	-3.5 up to -5.0 -1.4 up to -2.0	<-5.0 up to -14 <-2.0 up to -5.6	<-14 up to -50 <-5.6 up to -20	<-14 up to -50 <-5.6 up to -20	
Valve pallet	Aluminium	Stainless Steel	Stainless Steel	Stainless Steel	
Sealing	FEP	FEP	Metal to Metal	PTFE	

Table 7: Flange connection type

EN 1092-1; Form B1	other types upon request
ASME B16.5; 150 lbs RFSF	



for safety and environment

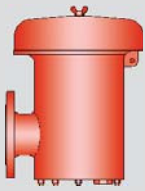

Pressure/Vacuum Relief Valve

Flow Capacity Charts

PROTEGO® PV/EBR-E

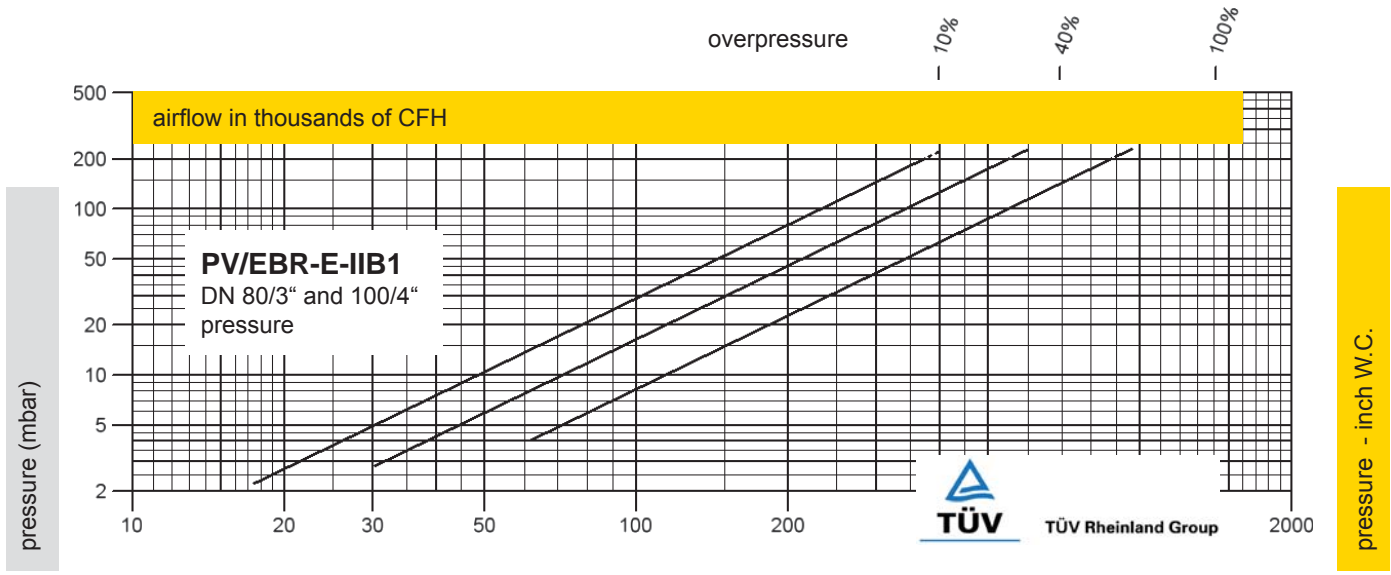

flow rate \dot{V} (m³/h) Leistung-000491-en

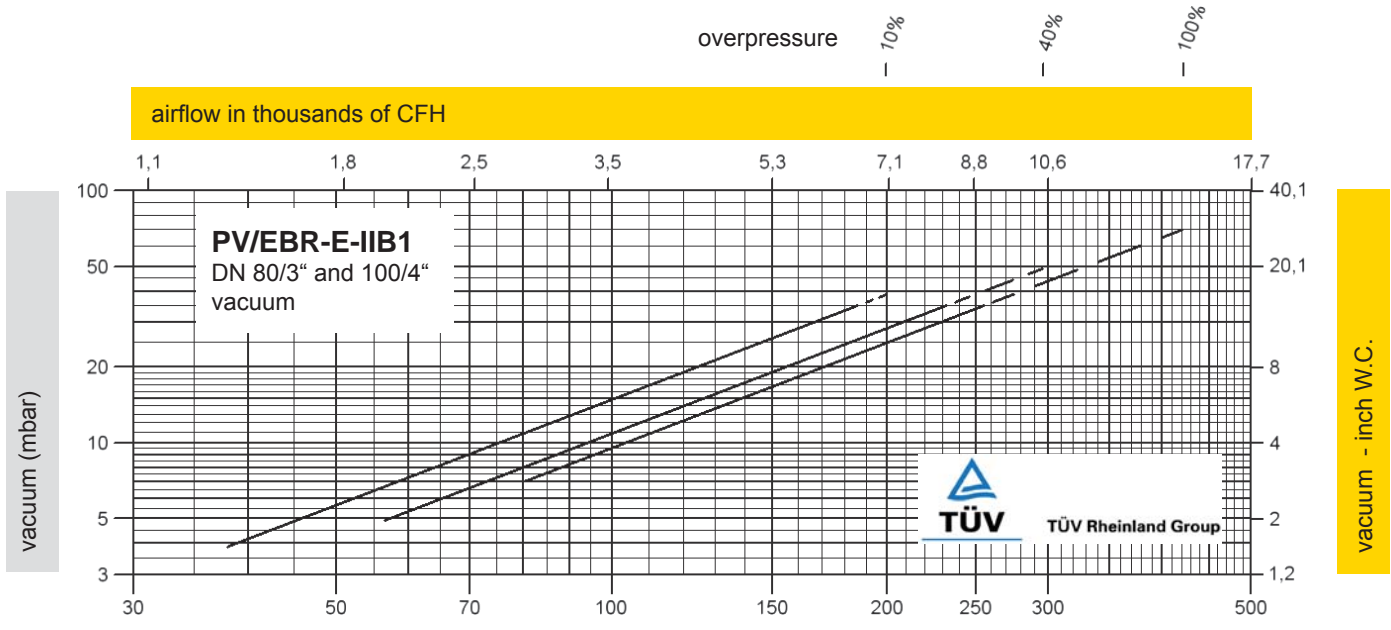

flow rate \dot{V} (m³/h) Leistung-000492-en

Remark

$$\text{set pressure} = \frac{\text{opening pressure resp. tank design pressure}}{1 + \frac{\text{overpressure \%}}{100\%}}$$

Set pressure = the valve starts to open

Opening pressure = set pressure plus overpressure

Overpressure % = percentage pressure increase over the set pressure

The flow capacity charts have been determined with a calibrated and TÜV certified flow capacity test rig. Volume flow \dot{V} in (m³/h) and CFH refer to the standard reference conditions of air ISO 6358 (20°C, 1bar). Conversion to other densities and temperatures refer to Vol. 1: "Technical Fundamentals".



Pressure/Vacuum Relief Valve atmospheric deflagration-proof

PROTEGO® VD/SV-AD and VD/SV-ADL

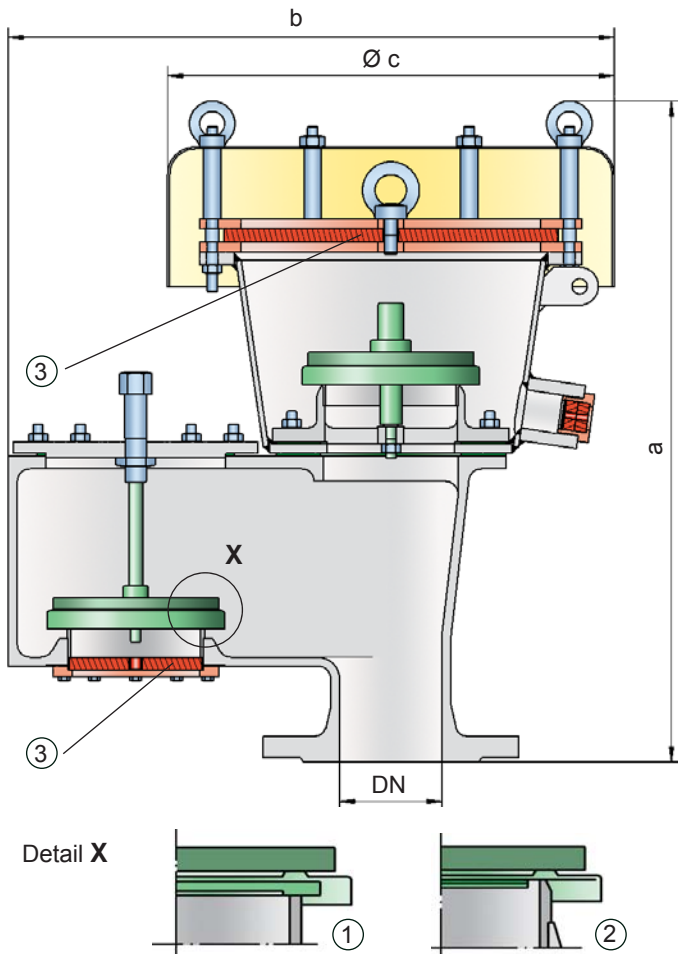

Settings:

pressure: +3.5 mbar up to +35 mbar
+1.4 inch W.C. up to +14 inch W.C.
vacuum: -2.0 mbar up to -35 mbar
-0.8 inch W.C. up to -14 inch W.C.

Higher and lower settings upon request

Function and Description

The deflagration proof VD/SV-AD(L) type PROTEGO® valve is a highly developed combined pressure/vacuum relief valve for high flow capacities with an integrated flame arrester unit. It is primarily used as a safety device for flame-transmission-proof in- and outbreathing in tanks, containers and process engineering apparatus. The valve offers reliable protection against excess pressure and vacuum, preventing outbreathing of product vapour and inbreathing of air almost up to the set pressure and also protects against atmospheric deflagration. The PROTEGO® flame arrester unit is designed to achieve minimum pressure drop with maximum safety. The deflagration-proof PROTEGO® VD/SV-AD(L) valve is available for substances from explosion groups IIA to IIB3 (NEC group D to C MESH ≥ 0.65 mm).

When the set pressure is reached, the valve starts to open and reaches full lift within 10% overpressure. This unique 10% technology enables a set pressure that is only 10% below the maximum allowable working pressure (MAWP) or maximum allowable working vacuum (MAWV) of the tank. After years of de-

velopment, this typical opening characteristic of a safety relief valve is now also available for the low pressure range.

The tank pressure is maintained up to the set pressure with a tightness that is far superior to the conventional standard due to our state of the art manufacturing technology. This feature is ensured by the valve seats made of high quality stainless steel and with individually lapped valve pallets (1) or with an air cushion seal (2) in conjunction with high quality FEP diaphragm. The valve pallets are also available with a PTFE seal to prevent the valve pallets from sticking when sticky products are used and to enable the use of corrosive fluids. After the in- and outbreathing is completed the valve reseats and provides a tight seal.

If the set pressure is exceeded, explosive gas/product-vapour air mixtures are released to the atmosphere. If this mixture ignites, the integrated PROTEGO® flame arrester unit (3) prevents flame transmission resulting from atmospheric deflagration into the tank. The vacuum side is also protected against atmospheric deflagration.

The valve can be used up to an operating temperature of +60°C / 140°F and meets the requirements of European tank design standard EN 14015 – Appendix L and ISO 28300 (API 2000).

Type-approved in accordance with the current ATEX Directive and EN ISO 16852 as well as other international standards.

Special Features and Advantages

- requires only 10% overpressure to full lift
- through 10% technology set pressures and vacuum closer to MAWP and MAWV can be reached which results in product loss reduction compared to conventional 40% and 100% overpressure technology vents (compare API 2000)
- more design flexibility through higher reseating pressures; vents reseat when conventional vent is still discharging costly product or nitrogen
- high performance seal reducing product loss below EPA's 500ppm rule preventing environmental pollution
- the valve disc is guided within the housing to protect against harsh weather conditions
- can be used as protective system according ATEX in areas subject to explosion hazards
- FLAMEFILTER® provides protection against atmospheric deflagration
- FLAMEFILTER® integrated into the valve saves space, weight and reduces cost
- FLAMEFILTER® protected from clogging through product vapour
- FLAMEFILTER® has a low pressure drop
- flame transmission proof condensate drain
- maintenance friendly design
- modular design enables individual FLAMEFILTER® and the valve pallet to be replaced
- superior technology for API tanks with low MAWP and MAWV



Vents - 10% Technology
(Flyer pdf)



Leak Rate/10% Technology
(Flyer pdf)

Design Types and Specifications

Any combination of vacuum and pressure levels can be set for the valve

The valve discs are weight-loaded.

There are two different designs:

Pressure/vacuum relief valve with housing, standard design

VD/SV-AD

Pressure/vacuum relief valve with expanded housing

VD/SV-ADL

Additional special devices available upon request

Table 1: Dimensions

Dimensions in mm / inches

To select the nominal size (DN), please use the flow capacity charts on the following pages

DN	VD/SV-AD		VD/SV-ADL	
	80 / 3"	100 / 4"	100 / 4"	150 / 6"
a	540 / 21.26	565 / 22.24	650 / 25.59	760 / 29.92
b	475 / 18.70	575 / 22.64	700 / 27.56	855 / 33.66
c	350 / 13.78	350 / 13.78	600 / 23.62	600 / 23.62

Table 2: Selection of explosion group

MESG	Expl. Gr. (IEC/CEN)	Gas Group (NEC)	Special approvals upon request
≥ 0,65 mm	IIB3	C	

Table 3: Material selection for housing

Design	A	B	Option: Housing with ECTFE-lining Special materials upon request
Housing	Steel	Stainless Steel	
Valve seats	Stainless Steel	Stainless Steel	
Gasket	PTFE	PTFE	
Weather hood	Stainless Steel	Stainless Steel	
Flame arrester unit	A, B	B	

Table 4: Material combinations of flame arrester units

Design	A	B	Special materials upon request
FLAMEFILTER® cage	Steel	Stainless Steel	
FLAMEFILTER®	Stainless Steel	Stainless Steel	

Table 5: Material selection for pressure valve pallet

Design	A	B	C	D	Special material as well as higher set pressure upon request
Pressure range (mbar) (inch W.C.)	+3.5 up to +5.0 +1.4 up to +2.0	>+5.0 up to +14 >+2.0 up to +5.6	>+14 up to +35 >+5.6 up to +14	>+14 up to +35 >+5.6 up to +14	
Valve pallet	Aluminium	Stainless Steel	Stainless Steel	Stainless Steel	
Sealing	FEP	FEP	Metal to Metal	PTFE	

Table 6: Material selection for vacuum valve pallet

Design	A	B	C	D	Special material as well as higher set vacuum upon request
Vacuum range (mbar) (inch W.C.)	-2.0 up to -3.5 -0.8 up to -1.4	<-3.5 up to -14 <-1.4 up to -5.6	<-14 up to -35 <-5.6 up to -14	<-14 up to -35 <-5.6 up to -14	
Valve pallet	Aluminium	Stainless Steel	Stainless Steel	Stainless Steel	
Sealing	FEP	FEP	Metal to Metal	PTFE	

Table 7: Flange connection type

EN 1092-1; Form B1	other types upon request
ASME B16.5; 150 lbs RFSF	





Pressure/Vacuum Relief Valve

Flow Capacity Charts

PROTEGO® VD/SV-AD and VD/SV-ADL

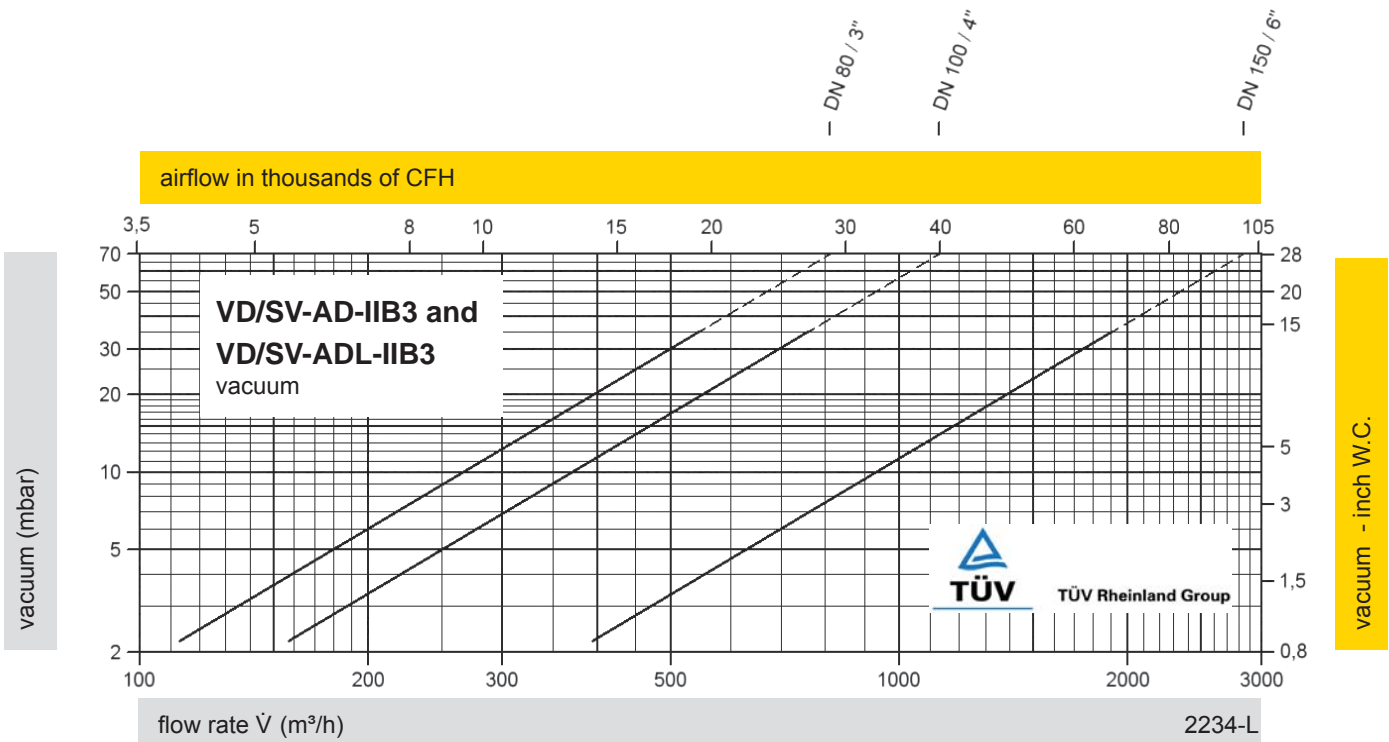
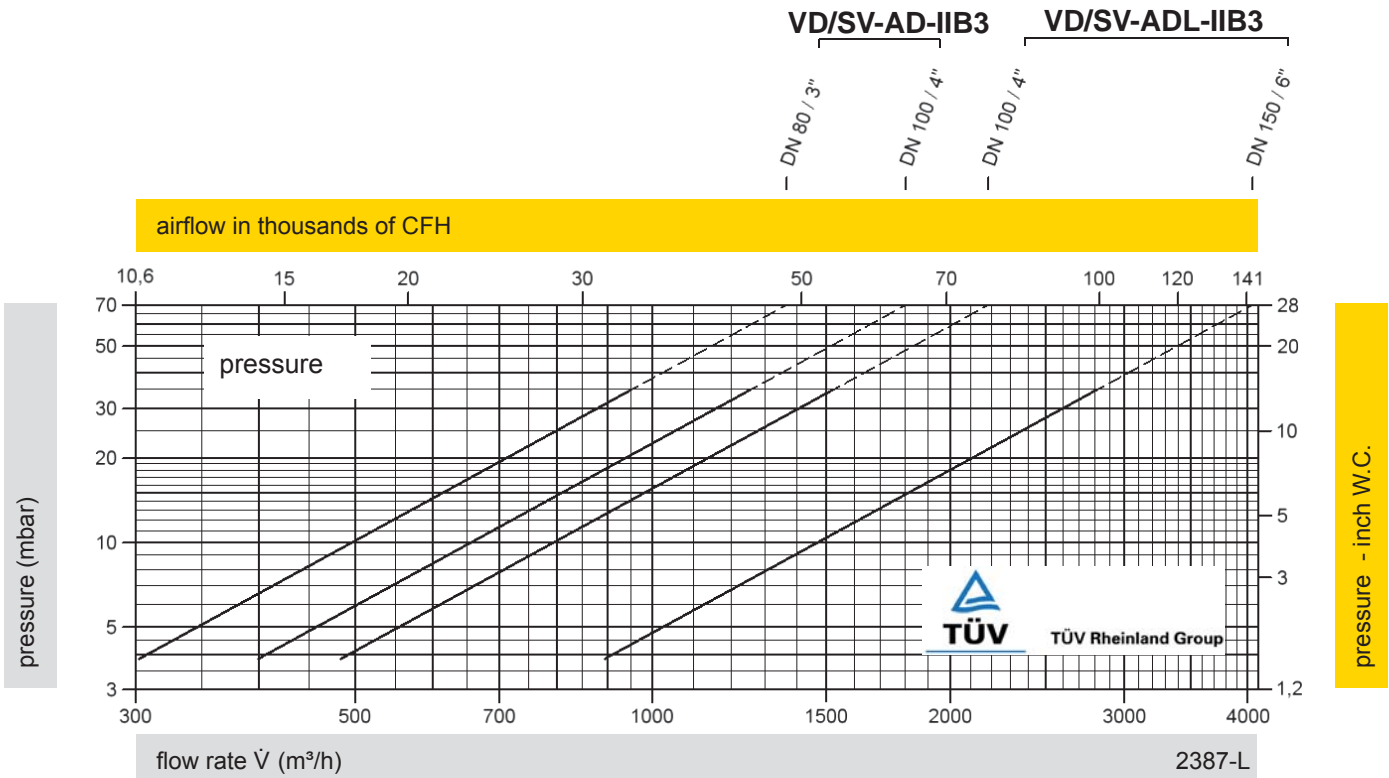

The flow capacity charts have been determined with a calibrated and TÜV certified flow capacity test rig. Volume flow \dot{V} in (m³/h) and CFH refer to the standard reference conditions of air ISO 6358 (20°C, 1bar). Conversion to other densities and temperatures refer to Vol. 1: "Technical Fundamentals".

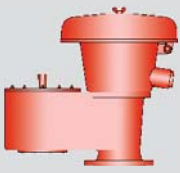

Pressure/Vacuum Relief Valve

deflagration- and endurance burning-proof



PROTEGO® VD/SV-HR

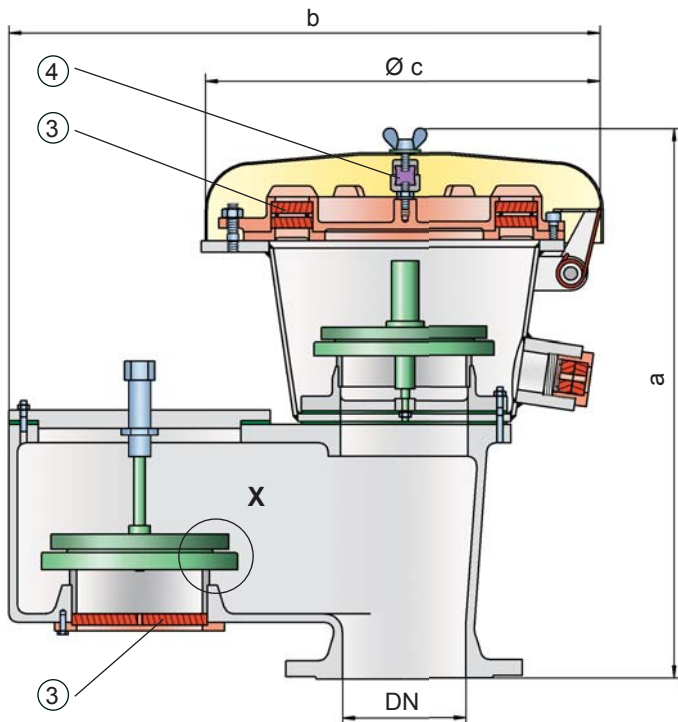

Detail X

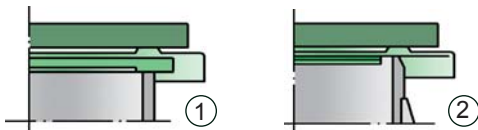

Settings:

pressure:	+3.5 mbar	up to +35 mbar
	+1.4 inch W.C.	up to +14 inch W.C.
vacuum:	-2.0 mbar	up to -35 mbar
	-0.8 inch W.C.	up to -14 inch W.C.

Higher and lower settings upon request

Function and Description

The deflagration-proof and endurance burning-proof VD/SV-HR type PROTEGO® valve is a highly developed combined pressure/vacuum relief valve for high flow capacities with an integrated flame arrester. It is primarily used as a safety device for flame-transmission-proof in- and outbreathing in tanks, containers and process engineering apparatus. The valve offers reliable protection against excess pressure and vacuum, preventing outbreathing of product vapour and inbreathing of air almost up to the set pressure and also protects against atmospheric deflagration as well as endurance burning if stabilized burning occurs. The PROTEGO® flame arrester unit is designed to achieve minimum pressure drop with maximum safety. The deflagration and endurance burning proof PROTEGO® VD/SV-HR device is available for substances from explosion groups IIA to IIB3 (NEC group D to C MESH ≥ 0.65 mm).

If the set pressure is reached for a valve approved for explosion Group IIA (NEC group D), the valve starts to open and reaches full lift within 10% overpressure. This unique 10% technology enables a set pressure that is only 10% below the maximum allowable working pressure (MAWP) of the tank. After years of development, this typical opening characteristic of a safety relief valve is now also available for the low pressure range. Valves approved for explosion group IIB3 (NEC group C) function proportionally, so the set pressures should be selected in relation to the proportional behaviour (such as a 10%, 40%, or 100%

overpressure from the set pressure to the relieving pressure at which the required flow performance is reached).

The tank pressure is maintained up to set pressure with a tightness that is far superior to the conventional standard due to our state of the art manufacturing technology. This feature is ensured by the valve seats made of high quality stainless steel and with individually lapped valve pallets (1) or with an air cushion seal (2) in conjunction with high quality FEP diaphragm. The valve pallets are also available with a PTFE seal to prevent the valve pallets from sticking when sticky products are used and to enable the use of corrosive fluids. After the excess pressure is discharged, the valve reseats and provides a tight seal.

If the set pressure is exceeded, explosive gas/product-vapour air mixtures are released to the atmosphere. If this mixture ignites, the integrated PROTEGO® flame arrester unit (3) prevents flame transmission into the tank. If additional mixture continues to flow and stabilized burning occurs, the integrated flame arrester unit prevents flashback as a result from endurance burning. The valve is protected and also fulfils its function under this severe service conditions. The spring loaded weather hood opens as soon as the fusible element (4) melts.

The valve can be used up to an operating temperature of +60°C / 140°F and meets the requirements of European tank design standard EN 14015 – Appendix L and ISO 28300 (API 2000).

Type-approved in accordance with the current ATEX Directive and EN ISO 16852 as well as other international standards.

Special Features and Advantages

- requires only 10% overpressure to full lift for explosion group IIA (NEC group D) vapours
- through 10% technology higher set pressures can be used which results in product loss reduction compared to conventional 40% and 100% overpressure technology vents (compare API 2000)
- more design flexibility through higher reseating pressures; vents reseal when conventional vent is still discharging costly product or nitrogen
- the valve disc is guided within the housing to protect against harsh weather conditions
- high performance seal reducing product loss below EPA's 500ppm rule preventing environmental pollution
- can be used as protective system according to ATEX in areas subject to explosion hazards
- safe against deflagration and endurance burning for explosion group IIA and IIB3 (NEC group D and C) vapours
- high flow capacity through large FLAMEFILTER® cross-section, results in low pressure drop
- FLAMEFILTER® provides protection against atmospheric deflagration and endurance burning
- FLAMEFILTER® integrated into the valve saves space, weight and reduces cost
- FLAMEFILTER® protected from clogging caused by product vapours
- flame transmission proof condensate drain
- maintenance friendly design
- modular design enables individual FLAMEFILTERS® and valve pallets to be replaced



Vents - 10% Technology
(Flyer pdf)



Leak Rate/10% Technology
(Flyer pdf)

Design and Specifications

Any combination of vacuum and pressure levels can be set for the valve.

The valve discs are weight-loaded.

Pressure/vacuum relief valve, basic design **VD/SV-HR**

Additional special devices available upon request

Table 1: Dimensions

Dimensions in mm / inches

To select the nominal size (DN), please use the flow capacity charts on the following pages

DN	80 / 3"	100 / 4"	
a	500 / 19.69	543 / 21.38	
b	477 / 18.78	577 / 22.72	
c	353 / 13.90	353 / 13.90	

Table 2: Selection of explosion group

MESG	Expl. Gr. (IEC/CEN)	Gas Group (NEC)	
> 0,90 mm	IIA	D	Special approvals upon request
≥ 0,65 mm	IIB3	C	

Table 3: Material selection for housing

Design	A	B	
Housing	Steel	Stainless Steel	Special materials upon request
Valve seats	Stainless Steel	Stainless Steel	
Gasket	PTFE	PTFE	
Weather hood	Steel	Stainless Steel	
Flame arrester unit	A	A	

Table 4: Material combination of flame arrester unit

Design	A	
FLAMEFILTER® cage	Stainless Steel	Special materials upon request
FLAMEFILTER®	Stainless Steel	

Table 5: Material selection for pressure valve pallet

Design	A	B	C	D	
Pressure range (mbar) (inch W.C.)	+3.5 up to +5.0 +1.4 up to +2.0	>+5.0 up to +14 >+2.0 up to +5.6	>+14 up to +35 >+5.6 up to +14	>+14 up to +35 >+5.6 up to +14	Special material as well as higher set pressure upon request
Valve pallet	Aluminium	Stainless Steel	Stainless Steel	Stainless Steel	
Sealing	FEP	FEP	Metal to Metal	PTFE	

Table 6: Material selection for vacuum valve pallet

Design	A	B	C	D	
Vacuum range (mbar) (inch W.C.)	-2.0 up to -3.5 -0.8 up to -1.4	<-3.5 up to -14 <-1.4 up to -5.6	<-14 up to -35 <-5.6 up to -14	<-14 up to -35 <-5.6 up to -14	Special material as well as higher set vacuum upon request
Valve pallet	Aluminium	Stainless Steel	Stainless Steel	Stainless Steel	
Sealing	FEP	FEP	Metal to Metal	PTFE	

Table 7: Flange connection type

EN 1092-1; Form B1	other types upon request
ASME B16.5; 150 lbs RFSF	



for safety and environment

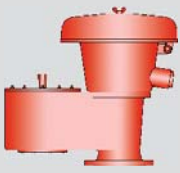

Pressure/Vacuum Relief Valve

Flow Capacity Charts

PROTEGO® VD/SV-HR

DN 80 / 3"
DN 100 / 4"

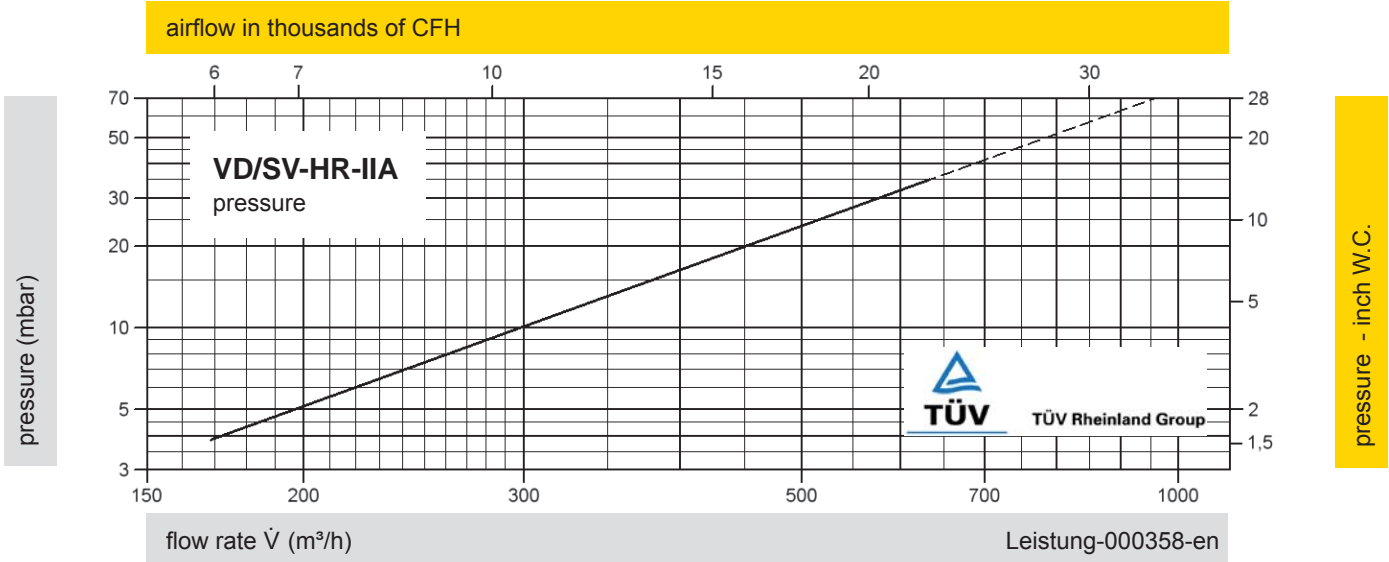

DN 80 / 3"
DN 100 / 4"

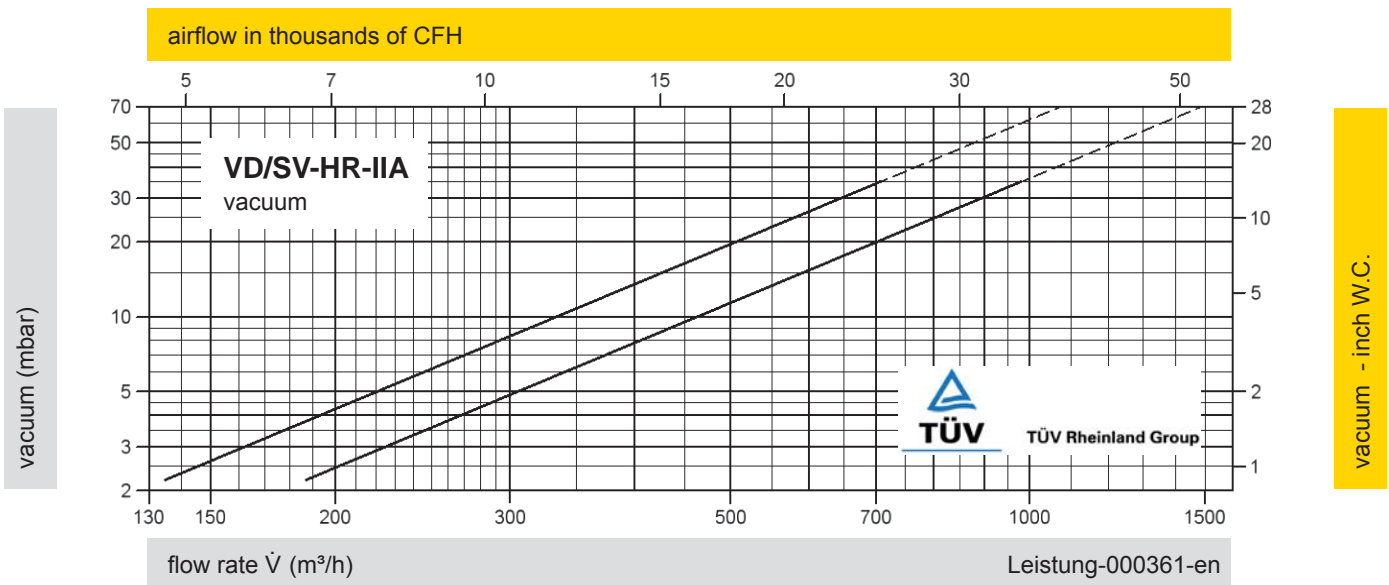

The flow capacity charts have been determined with a calibrated and TÜV certified flow capacity test rig.
Volume flow \dot{V} in (m³/h) and CFH refer to the standard reference conditions of air ISO 6358 (20°C, 1bar).
Conversion to other densities and temperatures refer to Vol. 1: "Technical Fundamentals".

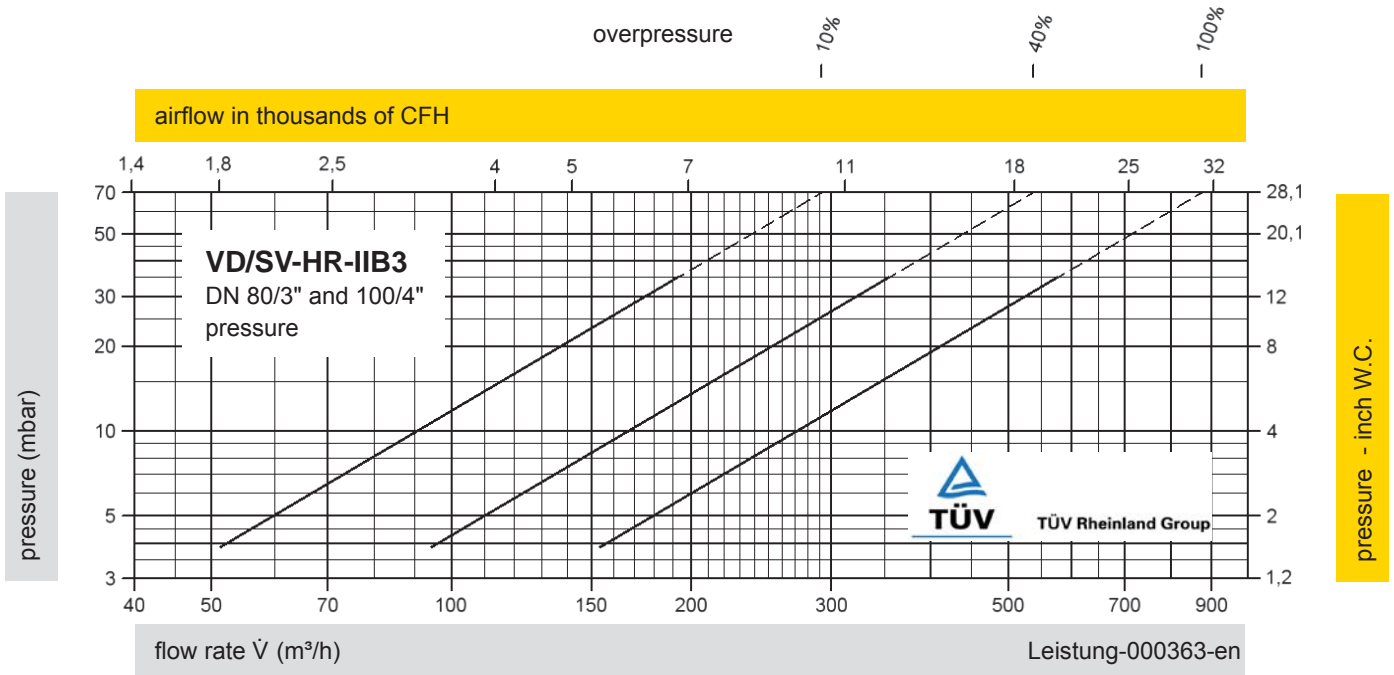

Remark

$$\text{set pressure} = \frac{\text{opening pressure resp. tank design pressure}}{1 + \frac{\text{overpressure \%}}{100\%}}$$

Set pressure = the valve starts to open

Opening pressure = set pressure plus overpressure

Overpressure % = percentage pressure increase over the set pressure

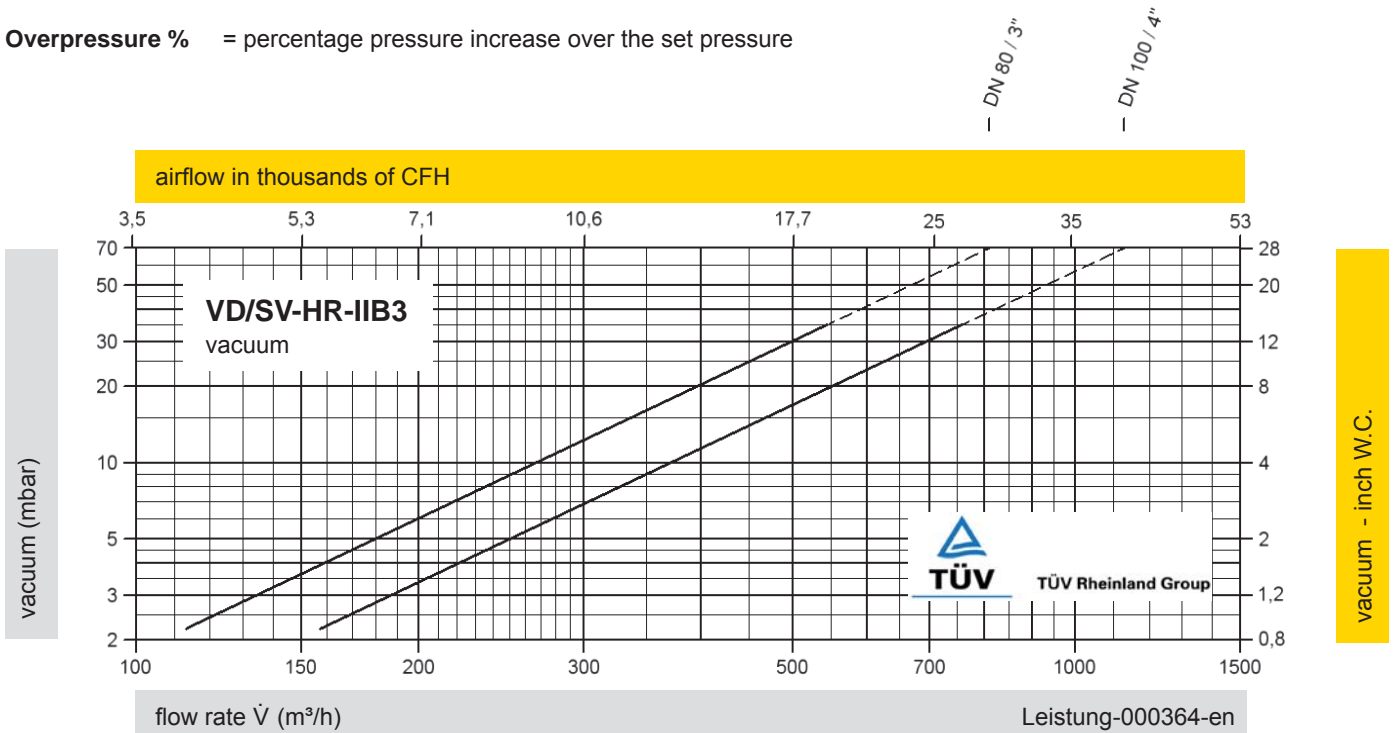

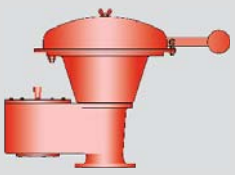

Pressure/Vacuum Relief Valve deflagration- and endurance burning-proof

PROTEGO® VD/SV-HRL

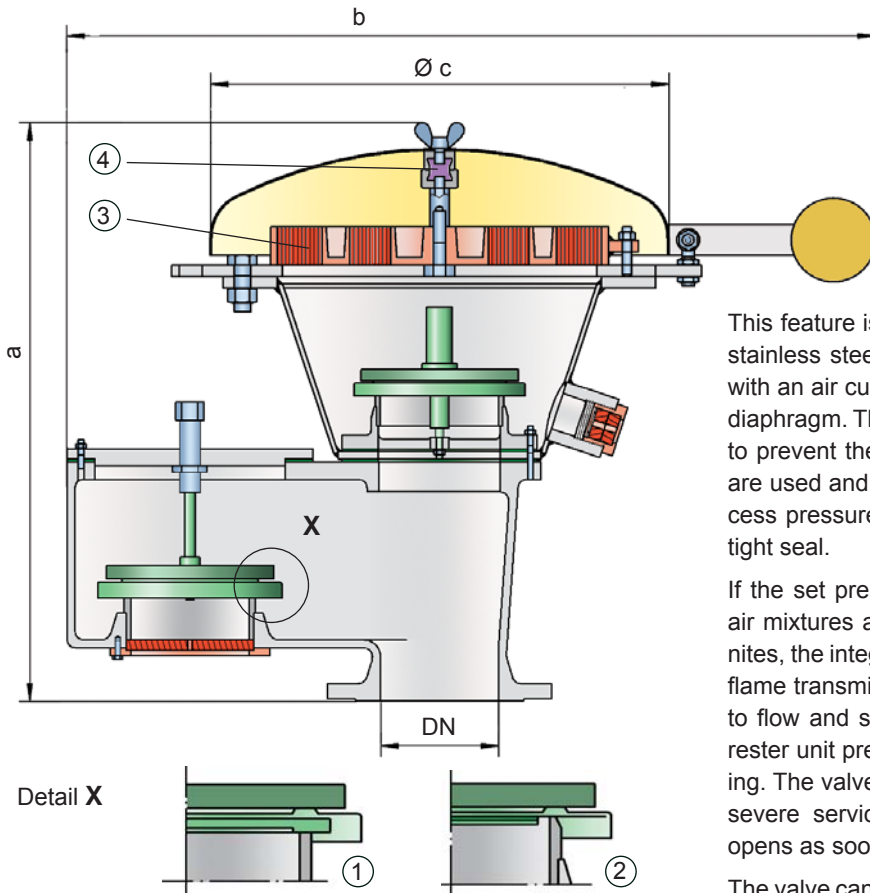

allowable working vacuum (MAWV) of the tank. After years of development, this typical opening characteristic of a safety relief valve is now also available for the low pressure range.

The tank pressure is maintained up to the set pressure with a tightness that is far superior to the conventional standard due to our state of the art manufacturing technology.

This feature is ensured by the valve seats made of high quality stainless steel and with individually lapped valve pallets (1) or with an air cushion seal (2) in conjunction with high quality FEP diaphragm. The valve pallets are also available with a PTFE seal to prevent the valve pallets from sticking when sticky products are used and to enable the use of corrosive fluids. After the excess pressure is discharged, the valve reseats and provides a tight seal.

If the set pressure is exceeded, explosive gas/product-vapour air mixtures are released to the atmosphere. If this mixture ignites, the integrated PROTEGO® flame arrester unit (3) prevents flame transmission into the tank. If additional mixture continues to flow and stabilized burning occurs, the integrated flame arrester unit prevents flashback as a result from endurance burning. The valve is protected and also fulfils its function under this severe service conditions. The spring loaded weather hood opens as soon as the fusible element (4) melts.

The valve can be used up to an operating temperature of +60°C / 140°F and meets the requirements of European tank design standard EN 14015 – Appendix L and ISO 28300 (API 2000).

Type-approved in accordance with the current ATEX Directive and EN ISO 16852 as well as other international standards.

Special Features and Advantages

- requires only 10% overpressure to full lift
- through 10% technology higher set pressures can be used which results in product loss reduction compared to conventional 40% and 100% overpressure technology vents (compare API 2000)
- increased design flexibility through higher reseating pressures; vents reseal when conventional vent is still discharging costly product or nitrogen
- high performance seal reducing product loss below EPA's 500ppm rule preventing environmental pollution
- the valve disc is guided within the housing to protect against harsh weather conditions
- can be used as protective system according ATEX in areas subject to explosion hazards
- FLAMEFILTER® provides protection against atmospheric deflagration and endurance burning
- FLAMEFILTER® integrated into the valve saves space, weight and reduces cost

Settings:

pressure:	+3.5 mbar	up to	+35 mbar
	+1.4 inch W.C.	up to	+14 inch W.C.
vacuum:	-2.0 mbar	up to	-35 mbar
	-0.8 inch W.C.	up to	-14 inch W.C.

Higher and lower settings upon request

Function and Description

The atmospheric deflagration and endurance burning proof VD/SV-HRL type PROTEGO® valve is a highly developed combined pressure/vacuum relief valve for high flow capacities with an integrated flame arrester. It is primarily used as a safety device for flame transmission proof in- and outbreathing on tanks, containers and process engineering apparatus. The valve offers reliable protection against excess pressure and vacuum, prevents the inbreathing of air and product losses almost up to the set pressure and also protects against atmospheric deflagration and endurance burning if stabilized burning occurs. The PROTEGO® flame arrester unit is designed to achieve minimum pressure drop with maximum safety. The PROTEGO® VD/SV-HRL device is available for substances of explosion group IIA (NEC group D MESH > 0.9 mm).

When the set pressure is reached, the valve starts to open and reaches full lift within 10% overpressure. This unique 10% technology enables a set pressure that is only 10% below the maximum allowable working pressure (MAWP) or maximum



Vents - 10% Technology
(Flyer pdf)



Leak Rate/10% Technology
(Flyer pdf)

- FLAMEFILTER® protected from clogging through product vapour
- FLAMEFILTER® has low pressure drop
- flame transmission proof condensate drain
- maintenance friendly design
- superior technology for API tanks

Design and Specifications

Any combination of vacuum and pressure levels can be set for the valve. The valve discs are weight-loaded.

Pressure/vacuum relief valve, basic design **VD/SV-HRL**

Additional special devices available upon request

Table 1: Dimensions

Dimensions in mm / inches

To select the nominal size (DN), please use the flow capacity charts on the following pages

DN	100 / 4"	150 / 6"
a	650 / 25.59	760 / 29.92
b	1000 / 39.37	1155 / 45.47
c	600 / 23.62	600 / 23.62

Table 2: Selection of explosion group

MESG	Expl. Gr. (IEC/CEN)	Gas Group (NEC)
> 0,90 mm	IIA	D

Special approvals upon request

Table 3: Material selection for housing

Design	A	B
Housing	Steel	Stainless Steel
Valve seats	Stainless Steel	Stainless Steel
Gasket	PTFE	PTFE
Weather hood	Steel	Stainless Steel
Flame arrester unit	A, B	B

Special materials upon request

Table 4: Material combinations of flame arrester unit

Design	A	B
FLAMEFILTER® cage	Steel	Stainless Steel
FLAMEFILTER®	Stainless Steel	Stainless Steel

Special materials upon request

Table 5: Material selection for pressure valve pallet

Design	A	B	C	D
Pressure range (mbar) (inch W.C.)	+3.5 up to +5.0 +1.4 up to +2.0	>+5.0 up to +14 >+2.0 up to +5.6	>+14 up to +35 >+5.6 up to +14	>+14 up to +35 >+5.6 up to +14
Valve pallet	Aluminium	Stainless Steel	Stainless Steel	Stainless Steel
Sealing	FEP	FEP	Metal to Metal	PTFE

Special material as well as higher set pressure upon request

Table 6: Material selection for vacuum valve pallet

Design	A	B	C	D
Vacuum range (mbar) (inch W.C.)	-2.0 up to -3.5 -0.8 up to -1.4	<-3.5 up to -14 <-1.4 up to -5.6	<-14 up to -35 <-5.6 up to -14	<-14 up to -35 <-5.6 up to -14
Valve pallet	Aluminium	Stainless Steel	Stainless Steel	Stainless Steel
Sealing	FEP	FEP	Metal to Metal	PTFE

Special material as well as higher set vacuum upon request

Table 7: Flange connection type

EN 1092-1; Form B1	other types upon request
ASME B16.5; 150 lbs RFSF	



PROTEGO
for safety and environment

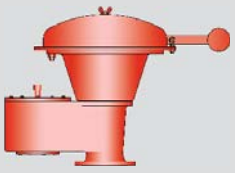

Pressure/Vacuum Relief Valve
Flow Capacity Charts

PROTEGO® VD/SV-HRL

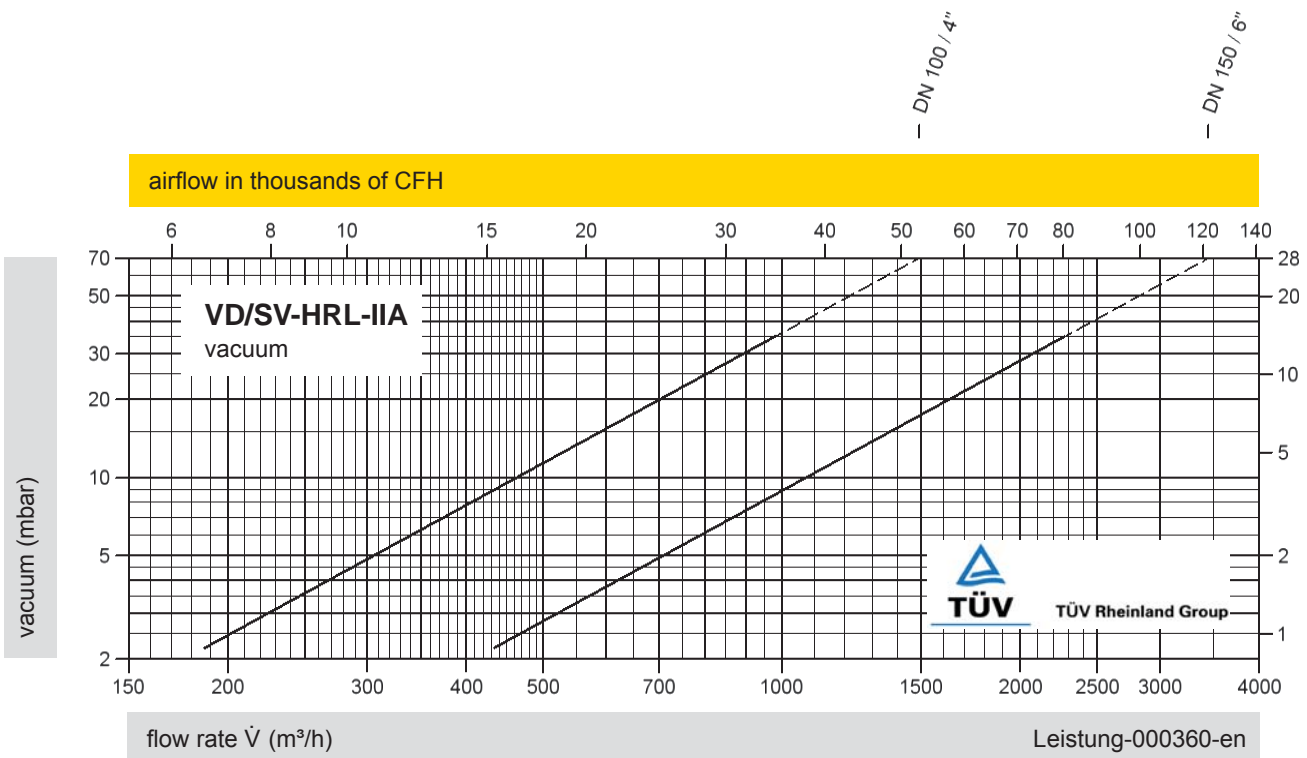
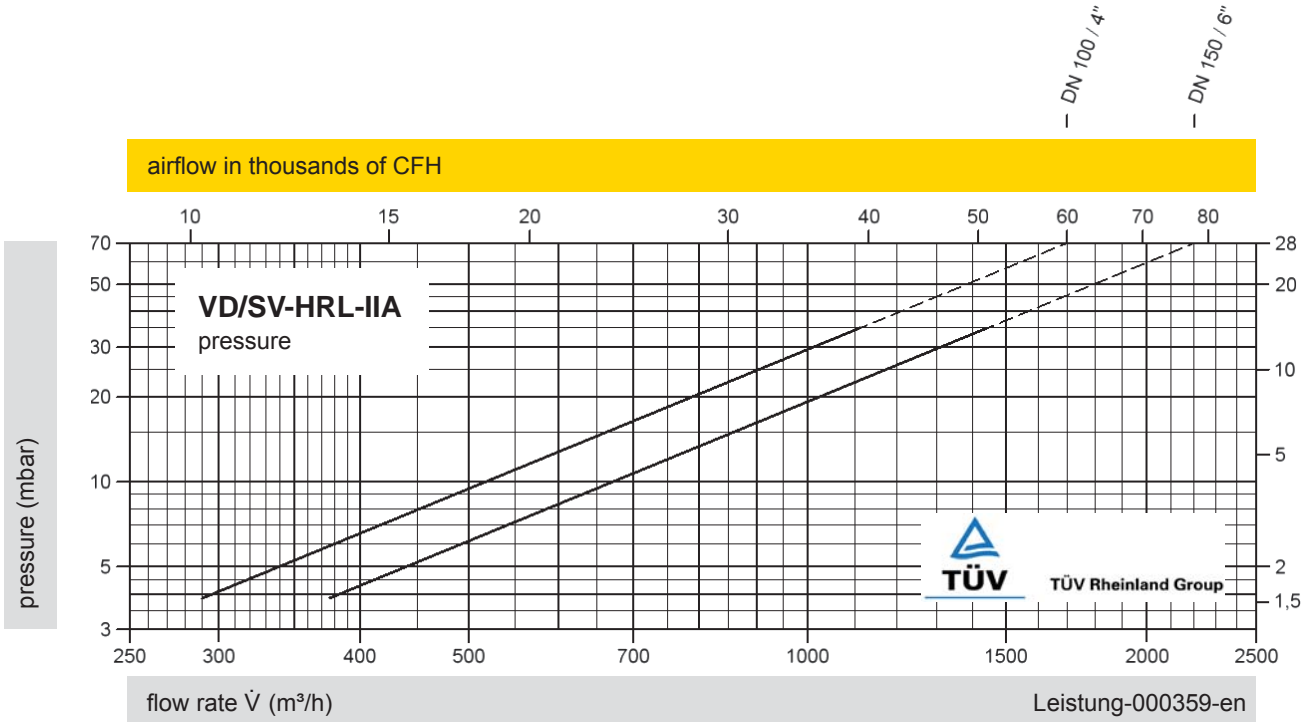

The flow capacity charts have been determined with a calibrated and TÜV certified flow capacity test rig.
Volume flow \dot{V} in (m³/h) and CFH refer to the standard reference conditions of air ISO 6358 (20°C, 1bar).
Conversion to other densities and temperatures refer to Vol. 1: "Technical Fundamentals".

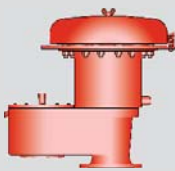

Pressure/Vacuum Relief Valve

deflagration- and endurance burning-proof



PROTEGO® VD-SV-EB

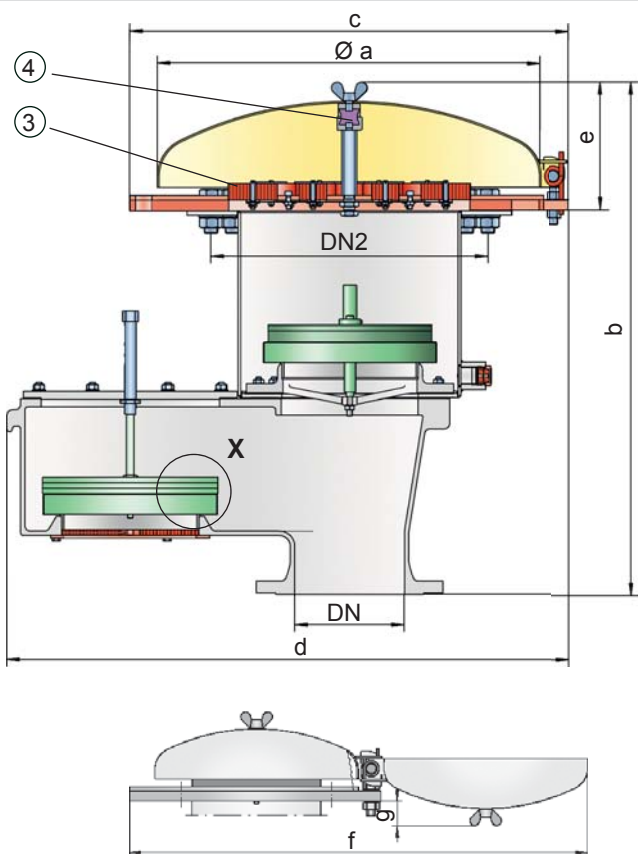

Detail X

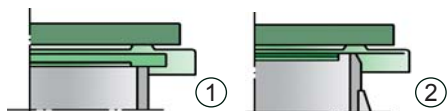

Settings:

pressure:	+2.0 mbar	up to	+60 mbar
	+0.8 inch W.C.	up to	+24 inch W.C.
vacuum:	-2.0 mbar	up to	-60 mbar
	-0.8 inch W.C.	up to	-24 inch W.C.

Higher and lower settings upon request

Function and Description

The deflagration-proof and endurance burning-proof VD-SV-EB type PROTEGO® valve is a highly developed combined pressure/vacuum relief valve for high flow capacities with the integrated flame arrester PROTEGO® EB. It is primarily used as a safety device for flame-transmission-proof in- and outbreathing in tanks, containers and process engineering apparatus. The valve offers reliable protection against excess pressure and vacuum, preventing outbreathing of product vapour and inbreathing of air almost up to the set pressure and also protects against atmospheric deflagration as well as endurance burning if stabilized burning occurs. The PROTEGO® flame arrester unit is designed to achieve minimum pressure drop with maximum safety. The deflagration and endurance burning proof PROTEGO® VD-SV-EB device is available for substances of explosion group IIA (NEC group D MESH > 0.9 mm).

When the set pressure is reached, the valve starts to open and reaches full lift within 10% overpressure. This unique 10% technology enables a set pressure that is only 10% below the maximum allowable working pressure (MAWP) of the tank.

After years of development, this typical opening characteristic of a safety relief valve is now also available for the low pressure range.

The tank pressure is maintained up to the set pressure with a tightness that is far superior to the conventional standard due to our state of the art manufacturing technology. This feature is ensured by the valve seats made of high quality stainless steel and with individually lapped valve pallets (1) or with an air cushion seal (2) in conjunction with a high quality FEP diaphragm. The valve pallets are also available with a PTFE seal to prevent the valve pallets from sticking when sticky products are used and to enable the use in corrosive fluids. After the excess pressure is discharged, the valve reseats and provides a tight seal.

If the set pressure is exceeded, explosive gas/product-vapour air mixtures are released to the atmosphere. If this mixture ignites, the integrated flame arrester PROTEGO® EB (3) prevents flame transmission into the tank. If additional mixture continues to flow and stabilized burning occurs, the integrated flame arrester unit prevents flashback as a result from endurance burning. The valve is protected and also fulfils its function under this severe service conditions. The spring loaded weather hood opens as soon as the fusible element (4) melts.

The valve can be used up to an operating temperature of +60°C / 140°F and meets the requirements of European tank design standard EN 14015 – Appendix L and ISO 28300 (API 2000).

Type-approved in accordance with the current ATEX Directive and EN ISO 16852 as well as other international standards.

Special Features and Advantages

- requires only 10% overpressure to full lift for explosion group IIA (NEC group D) vapours
- through 10% technology higher set pressures can be used which results in product loss reduction compared to conventional 40% and 100% overpressure technology vents (compare API 2000)
- more design flexibility through higher reseating pressures; vents reseal when conventional vent is still discharging costly product or nitrogen
- the valve disc is guided within the housing to protect against harsh weather conditions
- high performance seal reducing product loss below EPA's 500ppm rule preventing environmental pollution
- can be used as protective system according to ATEX in areas subject to explosion hazards
- safe against deflagration and endurance burning for explosion group IIA (NEC group D) vapours
- high flow capacity through large FLAMEFILTER® cross-section, results in low pressure drop
- FLAMEFILTER® provides protection against atmospheric deflagration and endurance burning
- FLAMEFILTER® integrated into the valve saves space, weight and reduces cost
- FLAMEFILTER® protected from clogging caused by product vapours
- flame transmission proof condensate drain
- maintenance friendly design
- modular design enables individual FLAMEFILTERS® and valve pallets to be replaced



Vents - 10% Technology
(Flyer pdf)



Leak Rate/10% Technology
(Flyer pdf)



Demonstration of endurance burning
Video

Design and Specifications

Any combination of vacuum and pressure levels can be set for the valve.
The valve discs are weight-loaded.

Pressure/vacuum relief valve, basic design **VD-SV-EB** -

Pressure/vacuum relief valve, with heating jacket **VD-SV-EB** -

Additional special devices available upon request

Table 1: Dimensions

Dimensions in mm / inches

DN	DN2	a	b	c	d	e	f	g
150 / 6"	400 / 16"	705 / 27.76	844 / 33.23	802 / 31.57	957 / 37.68	235 / 9.25	1500 / 59.06	109 / 4.29
200 / 8"	400 / 16"	705 / 27.76	939 / 36.97	802 / 31.57	1027 / 40.43	235 / 9.25	1500 / 59.06	109 / 4.29

Table 2: Selection of explosion group

MESG	Expl. Gr. (IEC/CEN)	Gas Group (NEC)	Special approvals upon request
> 0,90 mm	IIA	D	

Table 3: Material selection for housing

Design	A	B	Special materials upon request
Housing	Steel	Stainless Steel	
Heating jacket (VD-SV-EB-H-...)	Steel	Stainless Steel	
Valve seats	Stainless Steel	Stainless Steel	
Gasket	PTFE	PTFE	
Flange ring	Steel	Stainless Steel	
Weather hood	Steel	Stainless Steel	
Flame arrester unit	A	A, B	

Table 4: Material combination of flame arrester unit

Design	A	B	Special materials upon request
FLAMEFILTER® cage	Steel	Stainless Steel	
FLAMEFILTER®	Stainless Steel	Stainless Steel	
Safety bar	Stainless Steel	Stainless Steel	

Table 5: Material selection for pressure valve pallet

Design	A	B	C	D	E	F
Pressure range (mbar) (inch W.C.)	+2.0 up to +3.5 +0.8 up to +1.4	>+3.5 up to +14 >+1.4 up to +5.6	>+14 up to +35 >+5.6 up to +14	>+35 up to +60 >+14 up to +24	>+14 up to +35 >+5.6 up to +14	>+35 up to +60 >+14 up to +24
Valve pallet	Aluminium	Stainless Steel	Stainless Steel	Stainless Steel	Stainless Steel	Stainless Steel
Sealing	FEP	FEP	Metal to Metal	Metal to Metal	PTFE	PTFE

Special material as well as higher set pressure upon request

Table 6: Material selection for vacuum valve pallet

Design	A	B	C	D	E	F
Vacuum range (mbar) (inch W.C.)	-2.0 up to -3.5 -0.8 up to -1.4	<-3.5 up to -14 <-1.4 up to -5.6	<-14 up to -35 <-5.6 up to -14	<-14 up to -35 <-5.6 up to -14	<-35 up to -60 <-14 up to -24	<-35 up to -60 <-14 up to -24
Valve pallet	Aluminium	Stainless Steel	Stainless Steel	Stainless Steel	Stainless Steel	Stainless Steel
Sealing	FEP	FEP	Metal to Metal	PTFE	Metal to Metal	PTFE

Special material as well as higher set vacuum upon request

Table 7: Flange connection type

EN 1092-1; Form B1	other types upon request
ASME B16.5; 150 lbs RFSS	



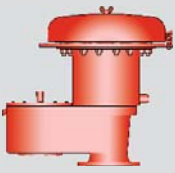

Pressure/Vacuum Relief Valve

Flow Capacity Charts

PROTEGO® VD-SV-EB-IIA

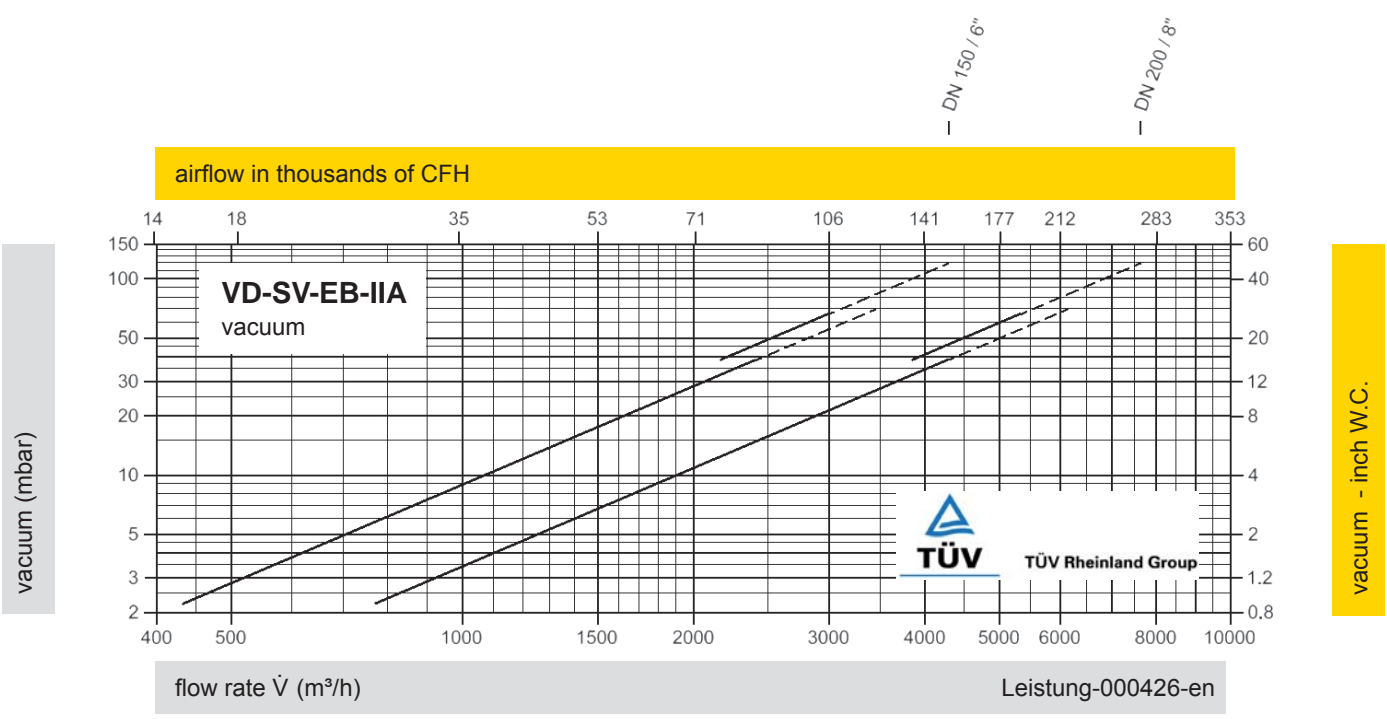
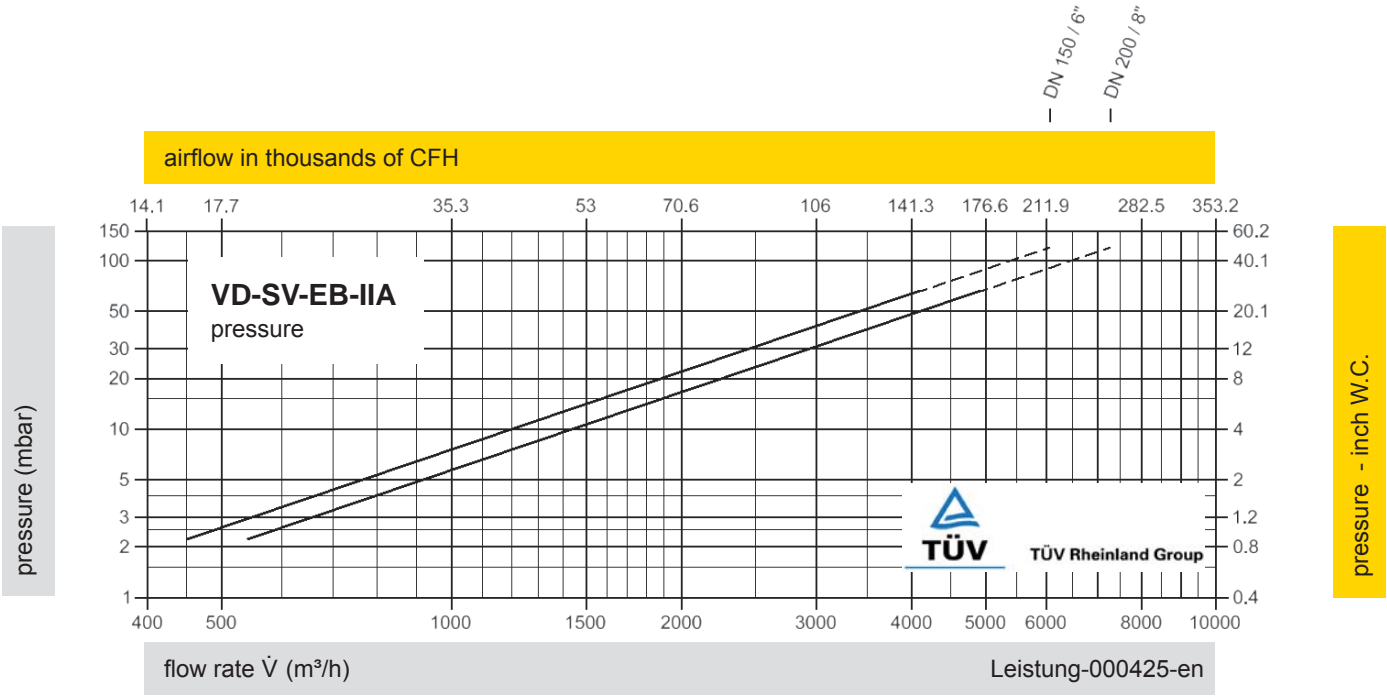

The flow capacity charts have been determined with a calibrated and TÜV certified flow capacity test rig. Volume flow \dot{V} in (m³/h) and CFH refer to the standard reference conditions of air ISO 6358 (20°C, 1bar). Conversion to other densities and temperatures refer to Vol. 1: "Technical Fundamentals".

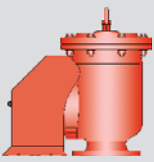

Pressure/Vacuum Relief Valve atmospheric deflagration-proof

PROTEGO® VD/TS

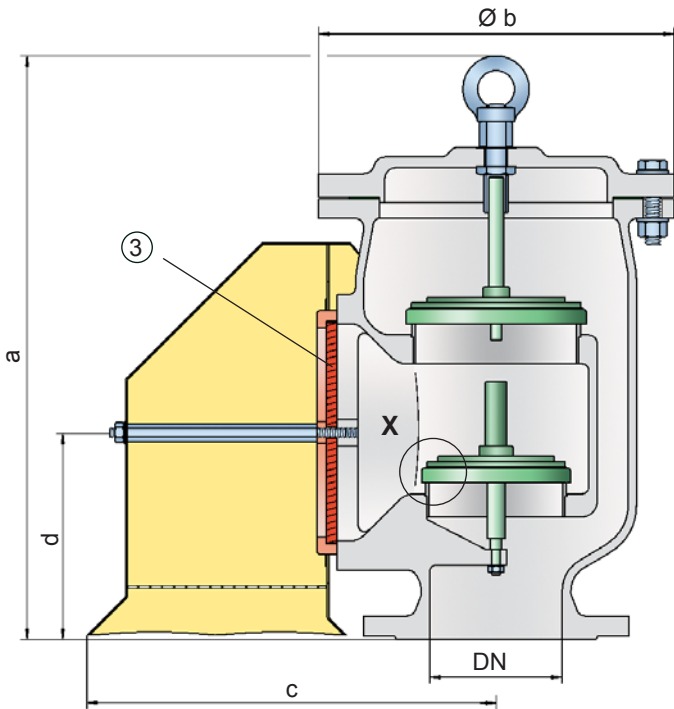

Detail X

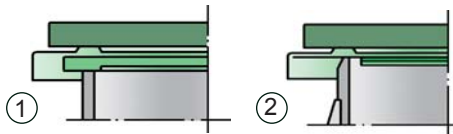

Settings:

pressure:	+3.5 mbar	up to	+50 mbar
	+1.4 inch W.C.	up to	+20 inch W.C.
vacuum:	-2.0 mbar	up to	-25 mbar
	-0.8 inch W.C.	up to	-10 inch W.C.

Higher and lower settings upon request

Function and Description

The atmospheric deflagration-proof VD/TS type PROTEGO® valve is a highly developed combined pressure/vacuum relief valve for high flow capacities with an integrated flame arrester unit. It is primarily used as a safety device for flame transmission proof in- and outbreathing on tanks, containers and process engineering apparatus. The valve offers reliable protection against excess pressure and vacuum, prevents the inbreathing of air and product losses almost up to the set pressure and also protects against atmospheric deflagration. The PROTEGO® flame arrester unit is designed to achieve minimum pressure drop with maximum safety. The PROTEGO® VD/TS device is available for substances from explosion groups IIA to IIB3 (NEC group D to C MESH ≥ 0.65 mm).

When the set pressure is reached, the valve starts to open and reaches full lift within 10% overpressure. This unique 10% technology enables a set pressure that is only 10% below the maximum allowable working pressure (MAWP) or maximum allowable working vacuum (MAWV) of the tank. After years of development, this typical opening characteristic of a safety relief valve is now also available for the low pressure range.

The tank pressure is maintained up to the set pressure with a tightness that is far superior to the conventional standard due to our state of the art manufacturing technology. This feature is ensured by the valve seats made of high quality stainless steel and with individually lapped valve pallets (1) or with an air cushion seal (2) in conjunction with high quality FEP diaphragm. The valve pallets are also available with a PTFE seal to prevent the valve pallets from sticking when sticky products are used and to enable the use of corrosive fluids. After the excess pressure is discharged, the valve reseats and provides a tight seal.

If the set pressure is exceeded, explosive gas/product-vapour air mixtures are released to the atmosphere. If this mixture ignites, the integrated PROTEGO® flame arrester unit (3) prevents flame transmission into the tank.

The standard design is tested at an operating temperature up to +60°C / 140°F and meets the requirements of European tank design standard EN 14015 – Appendix L and ISO 28300 (API 2000). In addition numerous versions for higher operating temperature are available.

Type-approved in accordance with the current ATEX Directive and ISO 16852 as well as other international standards.

Special Features and Advantages

- requires only 10% overpressure to full lift
- extreme tightness and hence least possible product losses and reduced environmental pollution
- through 10% technology higher set pressures can be used which results in product loss reduction compared to conventional 40% and 100% overpressure technology vents (compare API 2000)
- the valve disc is guided within the housing to protect against harsh weather conditions
- can be used as protective system according ATEX in areas subject to explosion hazards
- FLAMEFILTER® provides protection against atmospheric deflagration
- FLAMEFILTER® integrated into the valve saves space and reduces cost
- FLAMEFILTER® protected from clogging through product vapour
- PROTEGO® flame arrester unit has low pressure drop
- optimized flow performance
- maintenance friendly design
- sturdy housing design
- superior technology for API tanks

Design and Specifications

Any combination of vacuum and pressure levels can be set for the valve. The valve discs are weight loaded.

Pressure/vacuum relief valve, basic design **VD/TS-**
Additional special devices available upon request



PV-Valve with integrated Flame Arrester
Many traditional configurations are a safety risk. (Flyer pdf)



Safety Risk
(Video)



PV-Valve with integrated Flame Arrester (Video)



Vents - 10% Technology
(Flyer pdf)



Leak Rate/10% Technology
(Flyer pdf)

Table 1: Dimensions

Dimensions in mm / inches

To select the nominal size (DN), please use the flow capacity charts on the following pages

DN	50 / 2"	80 / 3"	100 / 4"	125 / 5"	150 / 6"	200 / 8"	250 / 10"	300 / 12"
a	340 / 13.39	430 / 16.93	490 / 19.29	610 / 24.02	610 / 24.02	705 / 27.76	765 / 30.12	930 / 36.61
b	210 / 8.27	280 / 11.02	310 / 12.20	390 / 15.35	390 / 15.35	445 / 17.52	505 / 19.88	560 / 22.05
c	206 / 8.11	277 / 10.91	347 / 13.66	427 / 16.81	427 / 16.81	534 / 21.02	604 / 23.78	823 / 32.40
d	125 / 4.92	150 / 5.91	180 / 7.09	230 / 9.06	230 / 9.06	270 / 10.63	310 / 12.20	445 / 17.52

Table 2: Selection of explosion group

MESG	Expl. Gr. (IEC/CEN)	Gas Group (NEC)	
≥ 0,65 mm	IIB3	C	Special approvals upon request

Table 3: Specification of max. operating temperature

≤ 60°C / 140°F	Tmaximum allowable operating temperature in °C	
-	Designation	higher operating temperatures upon request

Table 4: Material selection for housing

Design	A	C	D	E
Housing	Aluminium	Steel	Stainless Steel	Hastelloy
Valve seats	Stainless Steel	Stainless Steel	Stainless Steel	Hastelloy
Gasket	PTFE	PTFE	PTFE	PTFE
Weather hood	Aluminium	Aluminium	Stainless Steel	Hastelloy
Flame arrester unit	A	A	A	C
Pressure valve pallet	A-F	A-F	A-F	G-I
Vacuum valve pallet	A-E	A-E	A-E	F-H

Special materials upon request

Table 5: Material combination of flame arrester unit

Design	A	C	
FLAMEFILTER® cage	Stainless Steel	Hastelloy	Special materials upon request
FLAMEFILTER®	Stainless Steel	Hastelloy	

Table 6: Material selection for pressure pallet

Design	A	B	C	D	E
Pressure range (mbar) (inch W.C.)	+3.5 up to +5,0 +1.4 up to +2.0	>+5.0 up to +14 >+2.0 up to +5.6	>+14 up to +35 >+5.6 up to +14	>+35 up to +50 >+14 up to +20	>+14 up to +35 >+5.6 up to +14
Valve pallet	Aluminium	Stainless Steel	Stainless Steel	Stainless Steel	Stainless Steel
Sealing	FEP	FEP	Metal to Metal	Metal to Metal	PTFE
Weight	Stainless Steel	Stainless Steel	Stainless Steel	Lead	Stainless Steel
Design	F	G	H	I	
Pressure range (mbar) (inch W.C.)	>+35 up to +50 >+14 up to +20	+3.5 up to +5,0 +1.4 up to +2.0	>+5.0 up to +14 >+2.0 up to +5.6	>+14 up to +35 >+5.6 up to +14	
Valve pallet	Stainless Steel	Titanium	Hastelloy	Hastelloy	
Sealing	PTFE	FEP	FEP	Metal to Metal	
Weight	Lead	Hastelloy	Hastelloy	Hastelloy	

Special material as well as higher set pressure upon request



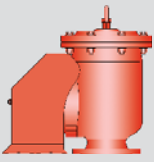

Pressure/Vacuum Relief Valve
atmospheric deflagration-proof

PROTEGO® VD/TS

Table 7: Material selection for vacuum pallet

Design	A	B	C	E	F
Vacuum range (mbar) (inch W.C.)	-2.0 up to -3.5 -0.8 up to -1.4	<-3.5 up to -14 <-1.4 up to -5.6	<-14 up to -25 <-5.6 up to -10	<-14 up to -25 <-5.6 up to -10	-2.0 up to -3.5 -0.8 up to -1.4
Valve pallet	Aluminium	Stainless Steel	Stainless Steel	Stainless Steel	Titanium
Sealing	FEP	FEP	Metal to Metal	PTFE	FEP
Weight	Stainless Steel	Stainless Steel	Stainless Steel	Stainless Steel	Hastelloy
Design	G	H	Special material as well as higher set vacuum upon request		
Vacuum range (mbar) (inch W.C.)	<-3.5 up to -14 <-1.4 up to -5.6	<-14 up to -25 <-5.6 up to -10			
Valve pallet	Hastelloy	Hastelloy			
Sealing	FEP	Metal to Metal			
Weight	Hastelloy	Hastelloy			

Table 8: Flange connection type

EN 1092-1; Form B1	other types upon request
ASME B16.5; 150 lbs RFSF	

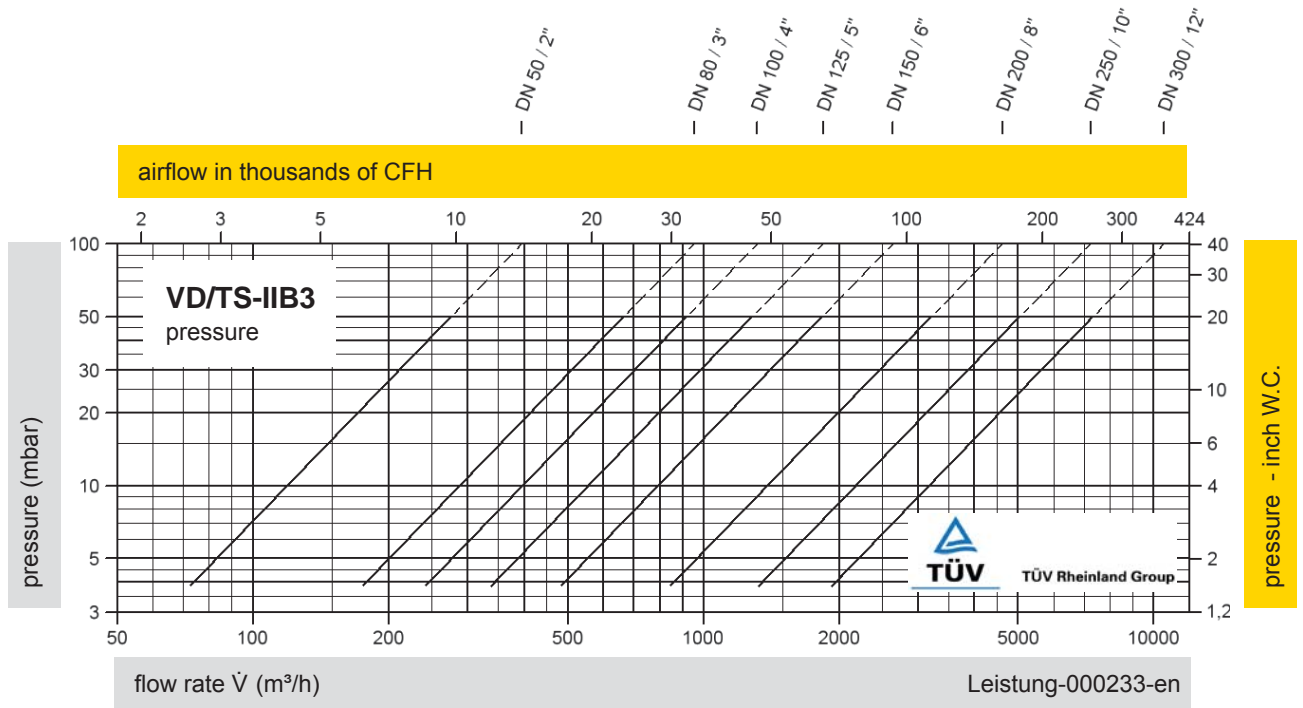

* at set pressure of +22 to +50 mbar /
 +8.8 to +20 inch W.C. a volume flow reduction
 of 15% has to be made on the vacuum side

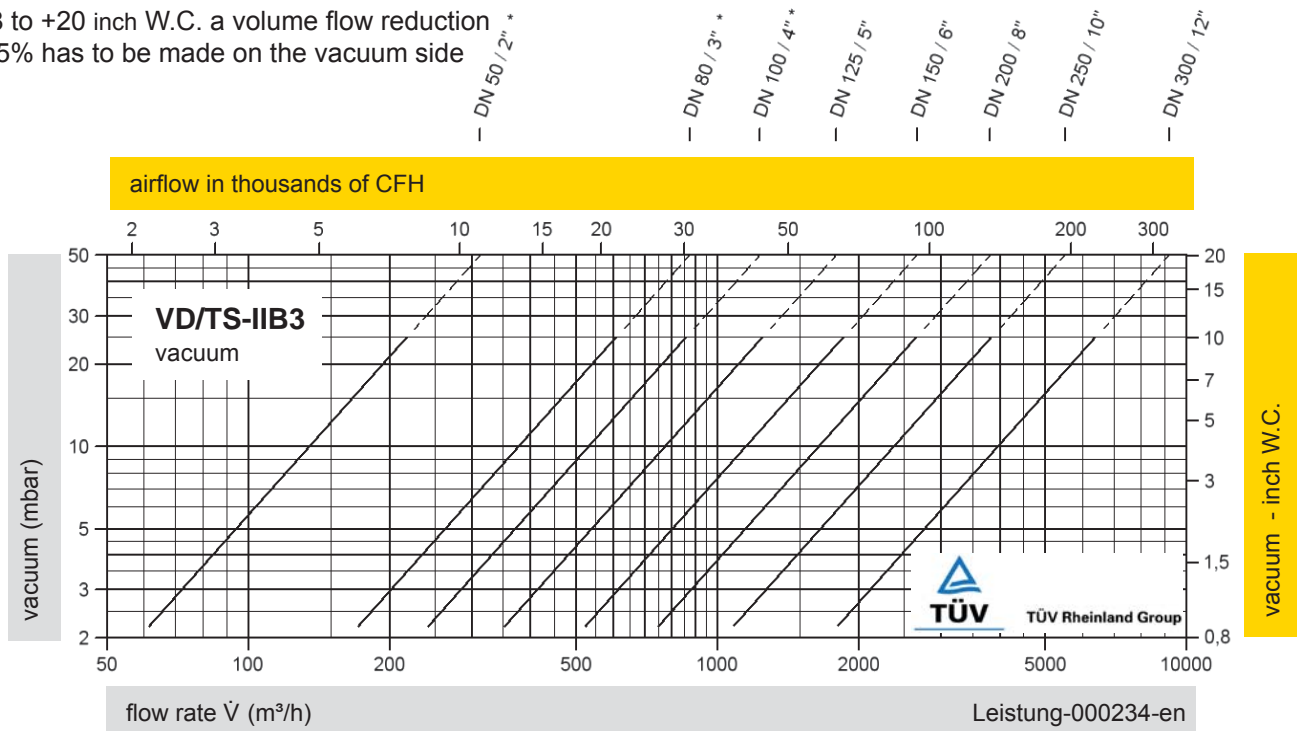

The flow capacity chart has been determined with a calibrated and TÜV certified flow capacity test rig.
 Volume flow \dot{V} in (m³/h) and CFH refer to the standard reference conditions of air ISO 6358 (20°C, 1bar).
 Conversion to other densities and temperatures refer to Vol. 1: "Technical Fundamentals".

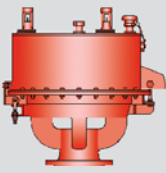

Pressure/Vacuum Diaphragm Valve deflagration- and endurance burning-proof

PROTEGO® UB/SF

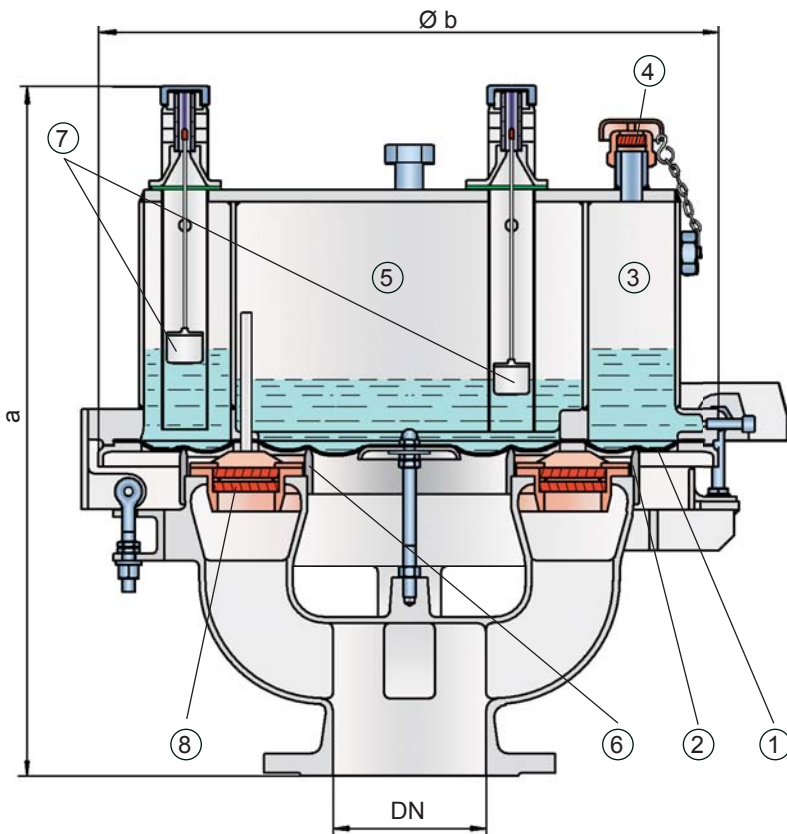

The set pressure is adjusted with a freeze resistant water-glycol mixture, which assures safe operation under extreme cold weather conditions. The PROTEGO® UB/SF valve is available for substances of explosion group IIB3 (NEC group C MESH ≥ 0.65 mm).

When the pressure in the tank reaches the set pressure, the diaphragm (1) on the outer valve seat ring (2) is lifted and vapours vent to the environment. The set pressure is adjusted by the liquid (water-glycol mixture) column height, which is filled into the outer ring chamber (3). The overpressure chamber is equipped with an opening (4) to keep the pressure in balance with the ambient pressure. The opening is equipped with a FLAMEFILTER® to avoid flame transmission into the overpressure chamber. If a vacuum builds up in the tank, it is transmitted through pressure balancing tubes into the vacuum chamber (5) (inner chamber). If the set vacuum, which depends on the liquid column height in the vacuum chamber, is reached the atmospheric pressure lifts the diaphragm off the inner valve seat ring (6). Ambient air can now flow into the tank. The liquid column heights, which affect the set pressures and vacuum, can be checked by floating level indicators (7).

The tank pressure is maintained up to the set pressure with a tightness that is far superior to the conventional standard due to our highly developed manufacturing technology. This is achieved because the liquid loaded diaphragm presses tightly around the special designed valve seat surface area, even when the operating pressure increases. This is extremely important to reduce leakage to an absolute minimum. After the excess pressure or vacuum is discharged, the valve reseats and provides a tight seal.

If the tank pressure exceeds the adjusted set pressure, explosive gas/product-vapour air mixtures exit. The speed at which these mixtures exit the annular gap between the diaphragm and the outer valve seat ring while overcoming the set pressure is much faster than the flame speed. If this mixture ignites, flashback into the tank is prevented. If the mixture flow continues, the dynamic flame arresting feature prevents flashback ignition even in the case of endurance burning. Even at relatively low flow rates, which occur during thermal outbreathing, the gap formed by the volumetric flow is so narrow that flames are extinguished in the gap and flashback is prevented. At very low pressure settings the explosion pressures resulting from an atmospheric deflagration may be strong enough to lift the diaphragm off the valve seat rings so that flashback could result. The ignition into the tank can be prevented by installing the PROTEGO® flame arrester unit (8). This flame arrester unit provides additional protection against atmospheric deflagration during regular maintenance and inspection.

Settings:

pressure:	DN 80	+3.5 mbar	up to +50 mbar
		+1.4 inch W.C.	up to +20 inch W.C.
	DN 100	+3.5 mbar	up to +45 mbar
		+1.4 inch W.C.	up to +18 inch W.C.
	DN 150	+3.5 mbar	up to +46 mbar
		+1.4 inch W.C.	up to +18.4 inch W.C.

Higher pressure settings up to +140 mbar (56.2 inch W.C.) in special design with additional liquid reservoir as well as lower pressure settings upon request.

vacuum:	-3.5 mbar	up to -35 mbar
	-1.4 inch W.C.	up to -14 inch W.C.

Higher and lower vacuum settings upon request

Function and Description

The deflagration- and endurance burning-proof UB/SF type PROTEGO® diaphragm valve is a state of the art pressure- and vacuum-relief valve combining the function of a dynamic and static flame arrester. Worldwide this design is unique. It is primarily used as a safety device for flame transmission proof in- and outbreathing on tanks, containers and process engineering apparatus. The valve offers reliable protection against excess pressure and vacuum, prevents the inbreathing of air and product losses almost up to the set pressure and protects against atmospheric deflagration and endurance burning if stabilized burning occurs. The PROTEGO® UB/SF diaphragm valve has proven its performance over many years in a great variety of severe applications in the petrochemical and chemical industry. Worldwide it is the only vent which functions in services such as styrene and acrylics.



UB/SF-IIB3
(Flyer pdf)



Frost-Proof P/V Diaphragm
Valve (Video)

The valve can be used up to an operating temperature of +60°C / 140°F and meets the requirements of European tank design standard EN 14015 – Appendix L and ISO 28300 (API 2000).

Type-approved in accordance with the current ATEX Directive and EN ISO 16852 as well as other international standards.

Special Features and Advantages

- high performance seal reducing product loss below EPA's 500ppm rule preventing environmental pollution
- set pressure close to opening pressure enables optimum pressure maintenance in the system
- high flow capacity
- can be used as a protective system according to ATEX in areas subject to an explosion hazard
- protection against atmospheric deflagrations and endurance burning for products up to explosion group IIB3 (NEC group C MESH ≥ 0.65 mm)
- minimum pressure drop of the FLAMEFILTER®
- flame-transmission-proof pressure and vacuum chambers
- freeze protection at sub-zero conditions
- self draining function for condensate
- liquid column height is monitored by level indicators
- easy maintenance through hinged vent cap
- modular design enables individual FLAMEFILTER® discs and valve diaphragm to be replaced
- particularly suitable for problematic products such as styrene, acrylics, etc.

Design Types and Specifications

Almost any combination of vacuum and pressure settings can be utilized for the valve. The diaphragm is pressurized by liquid. Higher pressures can be achieved upon request with a special liquid reservoir. When there is a substantial difference between the pressure and vacuum, special designs with weight-loaded vacuum discs are used.

There are two different designs:

Pressure/vacuum diaphragm valve, basic design **UB/SF - □**

Pressure/vacuum diaphragm valve with heating coil **UB/SF - □^H**
(max. heating fluid temperature +85°C / 185°F)

In addition to the standard design, a series of specially developed designs, which are particularly suitable for operating conditions to which these products are subjected, can be provided upon request (for example, for acrylics or styrene storage tanks, etc.).

Remark

$$\text{set pressure} = \frac{\text{opening pressure resp. tank design pressure}}{1,4}$$

Set pressure = the valve starts to open

Opening pressure = set pressure plus overpressure

Overpressure = pressure increase over the set pressure

Table 1: Dimensions

Dimensions in mm / inches

To select the nominal size (DN), please use the flow capacity charts on the following pages

DN	pressure	80 / 3"	100 / 4"	150 / 6"
a	up to +28 mbar / +11.2 inch W.C.	615 / 24.21	645 / 25.39	680 / 26.77
a	> +28 mbar / +11.2 inch W.C.	765 / 30.12	795 / 31.30	830 / 32.68
b		410 / 16.14	485 / 19.09	590 / 23.23

Pressure settings > +50 mbar / +20 inch W.C. (DN 80/3"), > +45 mbar / +18 inch W.C. (DN 100/4"), > +46 mbar / +18.4 inch W.C. (DN 150/6") with additional liquid reservoir - dimensions upon request

Dimensions for pressure/vacuum diaphragm valves with heating coil upon request

Table 2: Selection of explosion group

MESH	Expl. Gr. (IEC/CEN)	Gas Group (NEC)	Special approvals upon request
$\geq 0,65$ mm	IIB3	C	



PROTEGO
for safety and environment

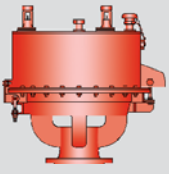

Pressure/Vacuum Diaphragm Valve
deflagration- and endurance burning-proof

PROTEGO® UB/SF

Table 3: Material selection for housing

Design	C	D
Housing	Steel	Stainless Steel
Valve top	Stainless Steel	Stainless Steel
Heating coil (UB/SF-H-...)	Stainless Steel	Stainless Steel
Valve seats	Stainless Steel	Stainless Steel
Gasket	FPM	PTFE
Diaphragm	A, B	A, B
Flame arrester unit	C	C

Option: Housing with ECTFE-lining
Special materials upon request



Coated Devices
(Flyer pdf)

Table 4: Material selection for diaphragm

Design	A	B
Diaphragm	FPM	FEP

Special materials upon request

Table 5: Material combinations of flame arrester unit

Design	C
FLAMEFILTER® cage	Stainless Steel
FLAMEFILTER®	Stainless Steel
Spacer	Stainless Steel

Special materials upon request

Table 6: Flange connection type

EN 1092-1; Form B1
ASME B16.5; 150 lbs RFSF

other types upon request

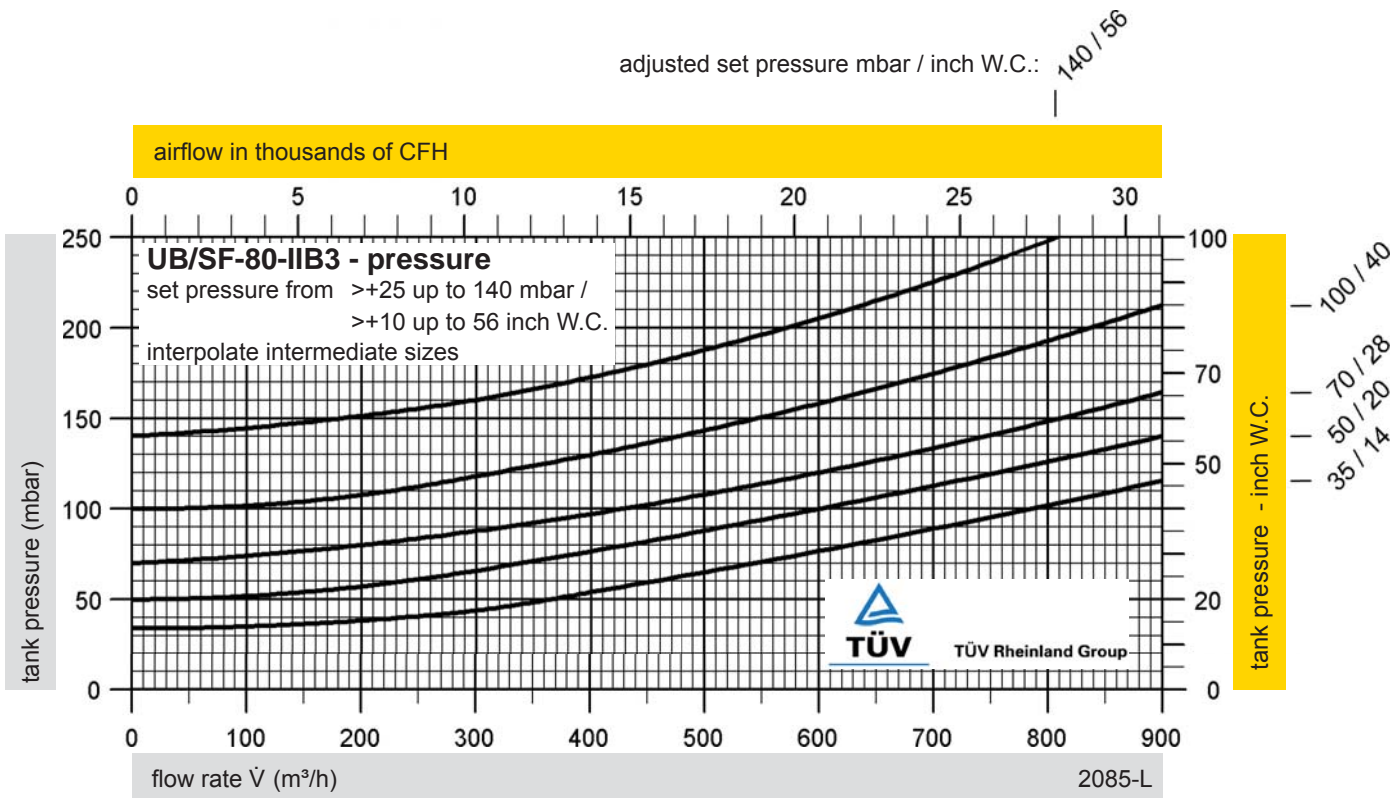
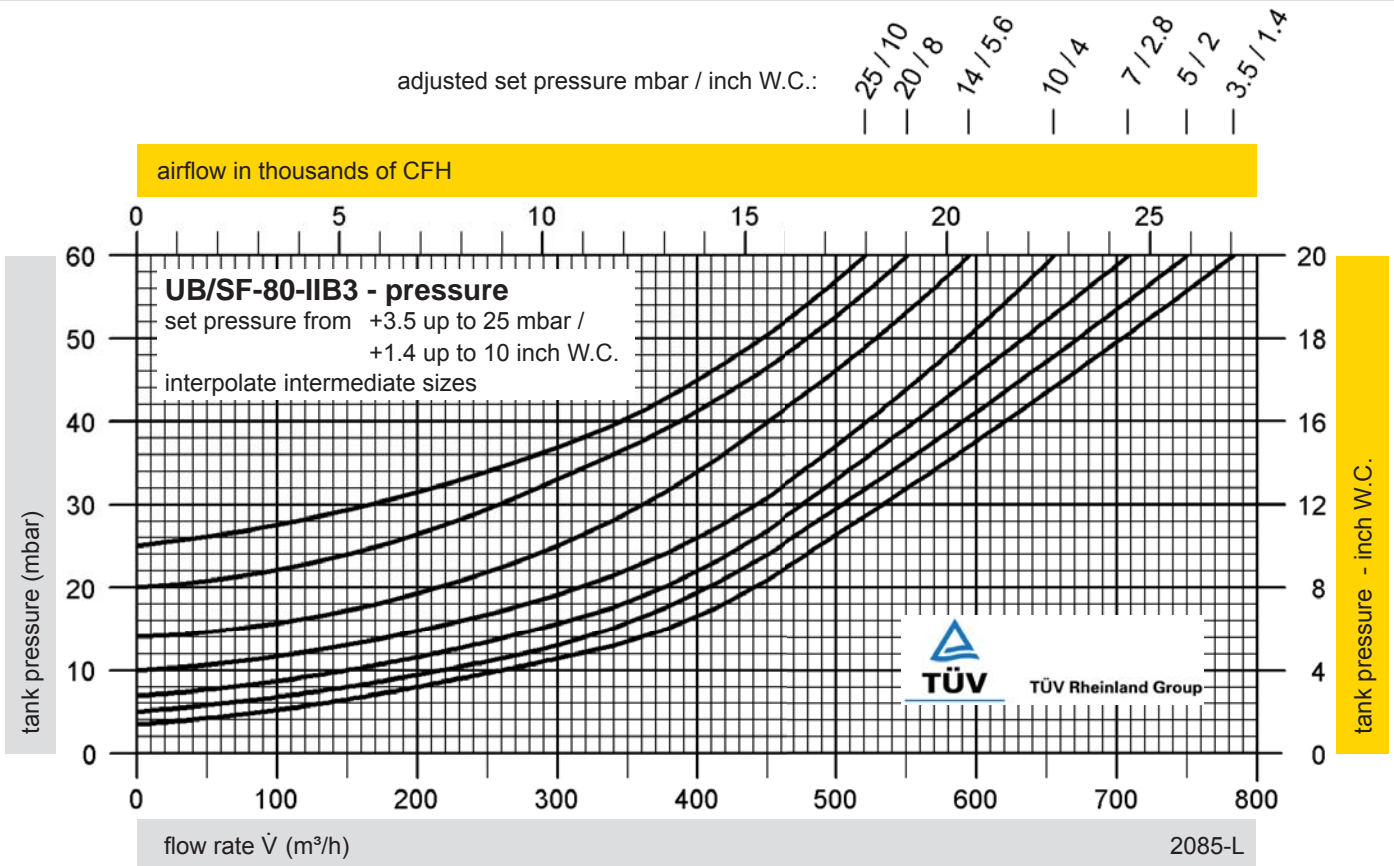

The flow capacity chart has been determined with a calibrated and TÜV certified flow capacity test rig.
 Volume flow \dot{V} in (m³/h) and CFH refer to the standard reference conditions of air ISO 6358 (20°C, 1bar).
 Conversion to other densities and temperatures refer to Vol. 1: "Technical Fundamentals".



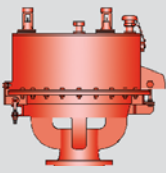

Pressure/Vacuum Diaphragm Valve

Flow Capacity Charts - Pressure

PROTEGO® UB/SF-100

adjusted set pressure mbar / inch W.C.: 25 / 10

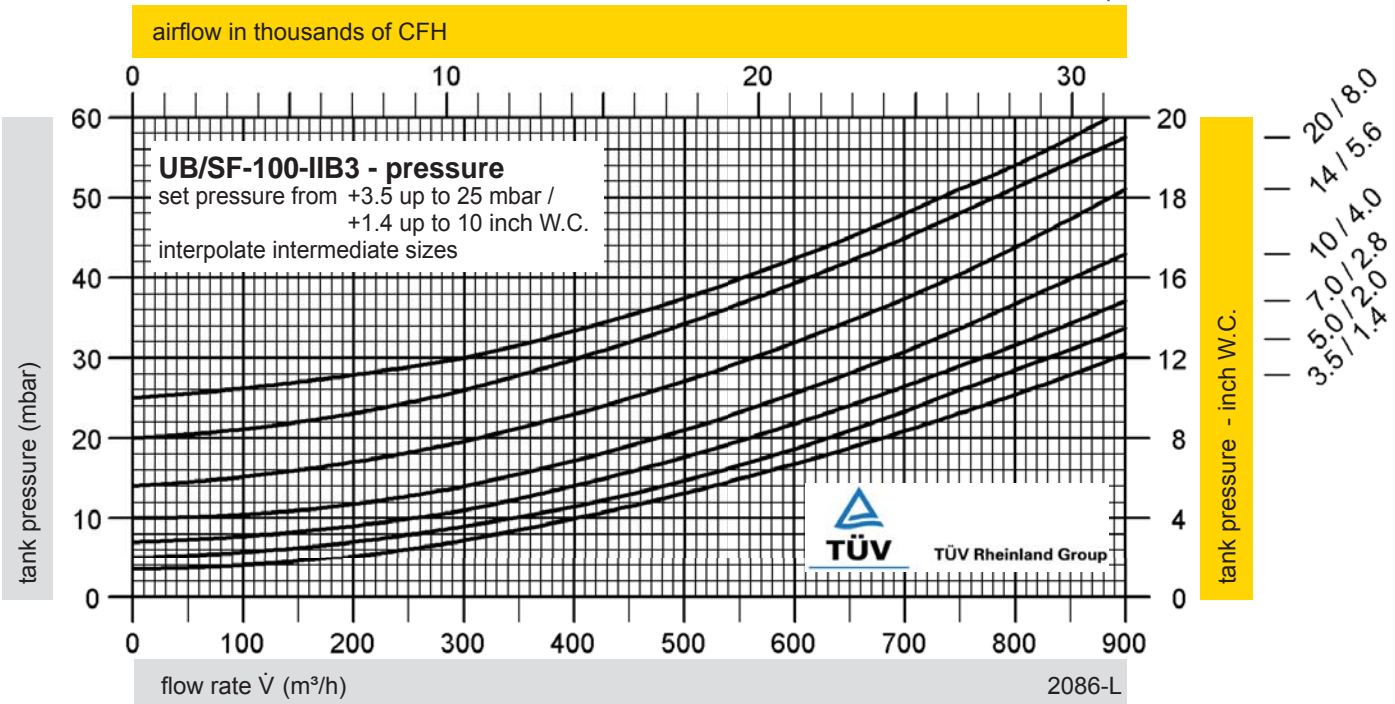

adjusted set pressure mbar / inch W.C.: 140 / 56

100 / 40

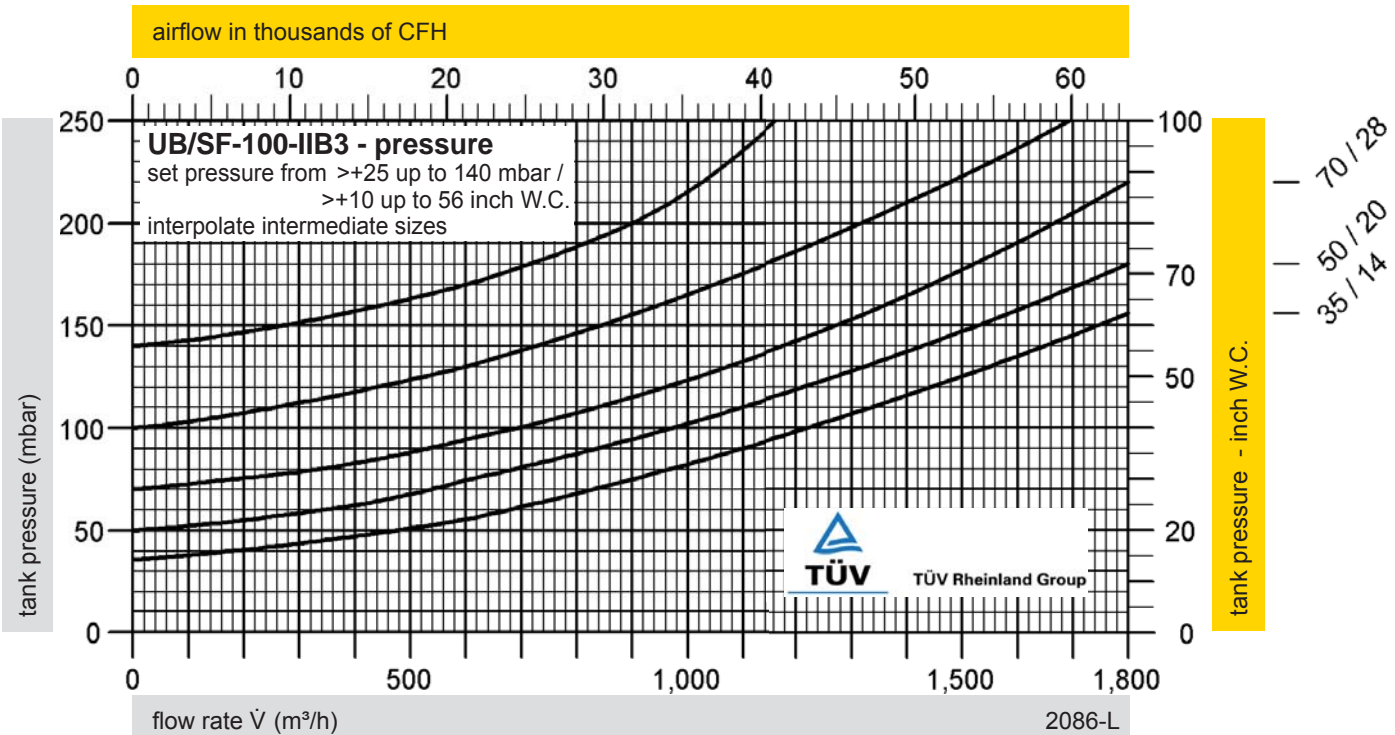

The flow capacity charts have been determined with a calibrated and TÜV certified flow capacity test rig. Volume flow \dot{V} in (m³/h) and CFH refer to the standard reference conditions of air ISO 6358 (20°C, 1bar). Conversion to other densities and temperatures refer to Vol. 1: "Technical Fundamentals".

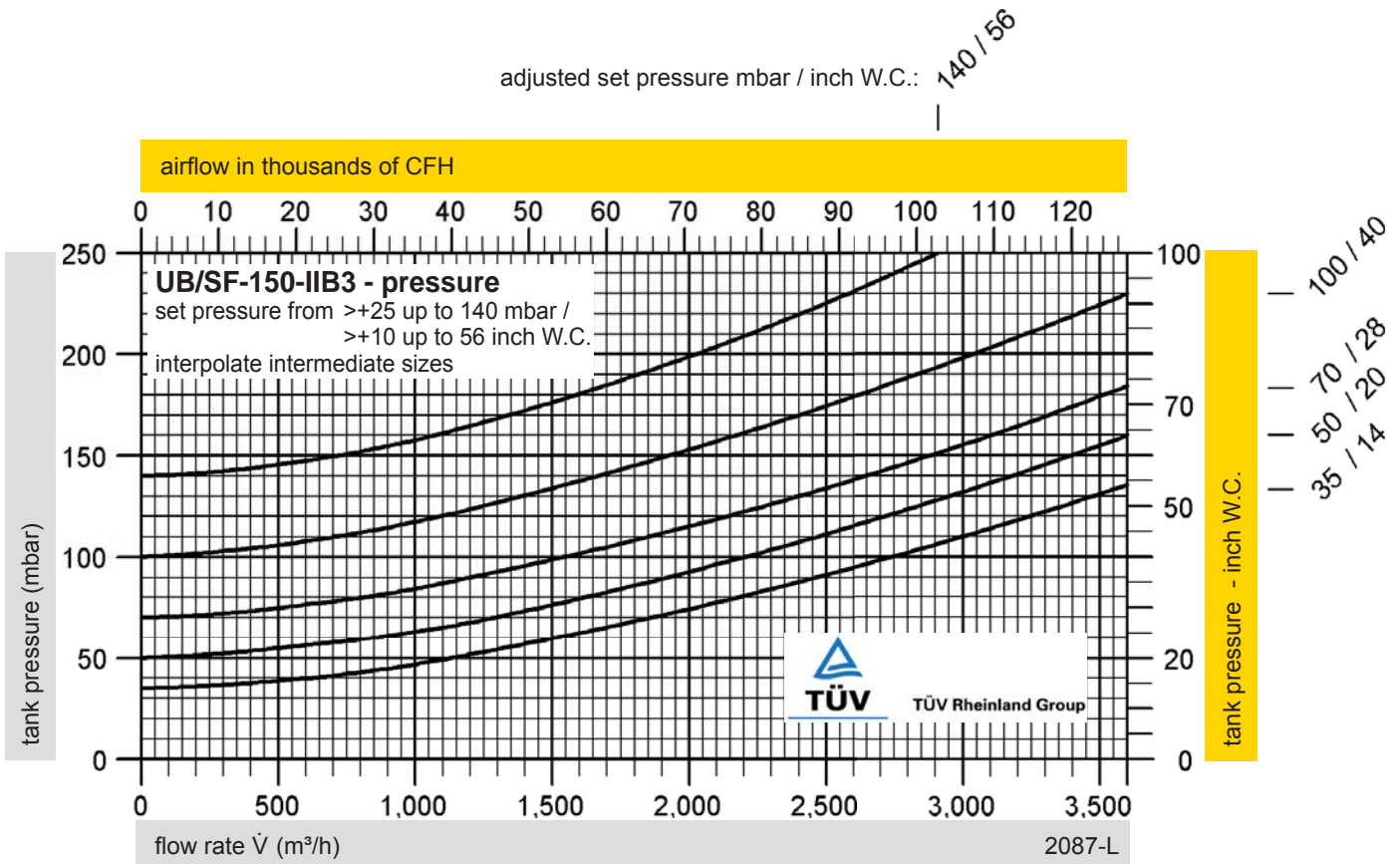
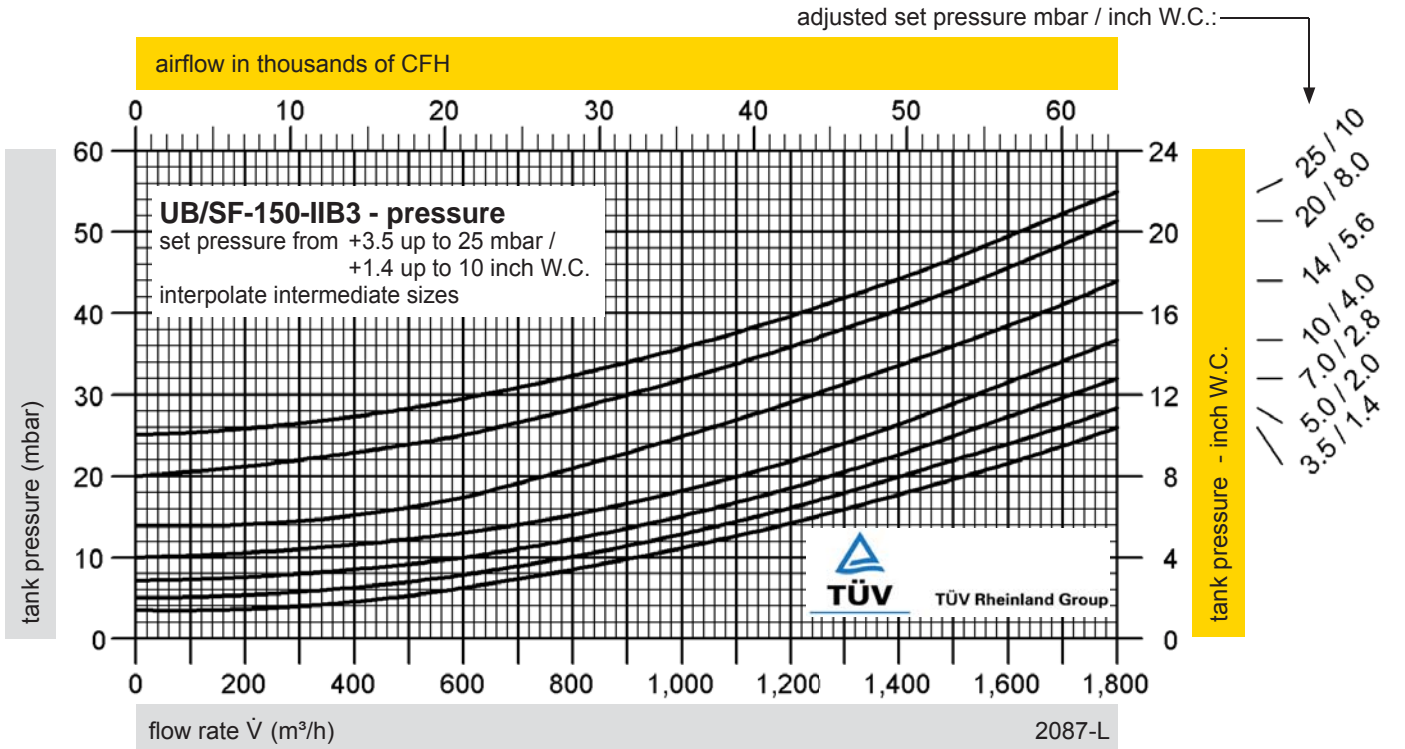

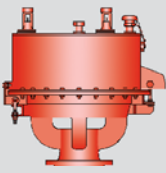

Pressure/Vacuum Diaphragm Valve

Flow Capacity Charts - Vacuum

PROTEGO® UB/SF-80 and 100

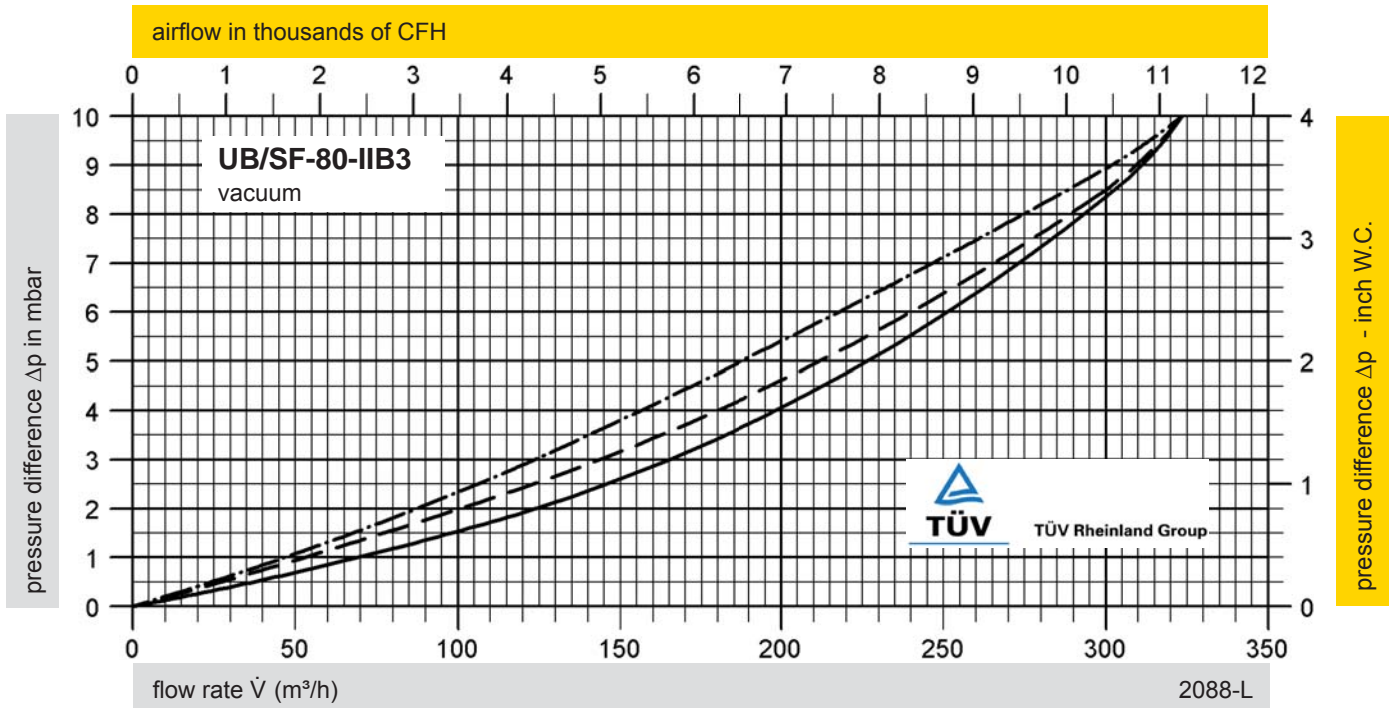

pressure difference = max. allowable tank design vacuum - valve set vacuum

adjusted set vacuum:

- ≤ -5 mbar / ≤ -2 inch W.C.
- - - - - > -5 mbar up to ≤ -7 mbar / > -2 inch W.C. up to ≤ -2.8 inch W.C.
- . - . - > -7 mbar up to ≤ -35 mbar / > -2.8 inch W.C. up to ≤ -14 inch W.C.

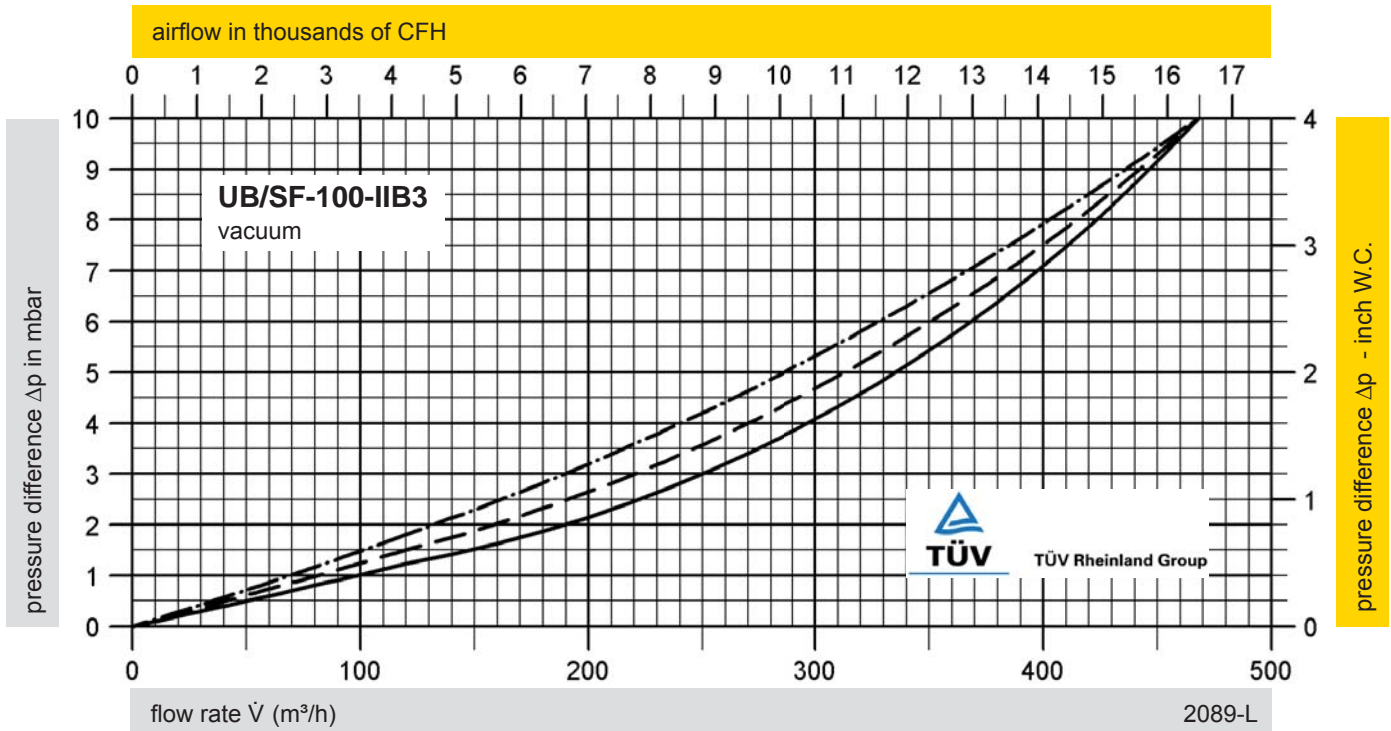

The flow capacity charts have been determined with a calibrated and TÜV certified flow capacity test rig. Volume flow \dot{V} in (m³/h) and CFH refer to the standard reference conditions of air ISO 6358 (20°C, 1bar). Conversion to other densities and temperatures refer to Vol. 1: "Technical Fundamentals".

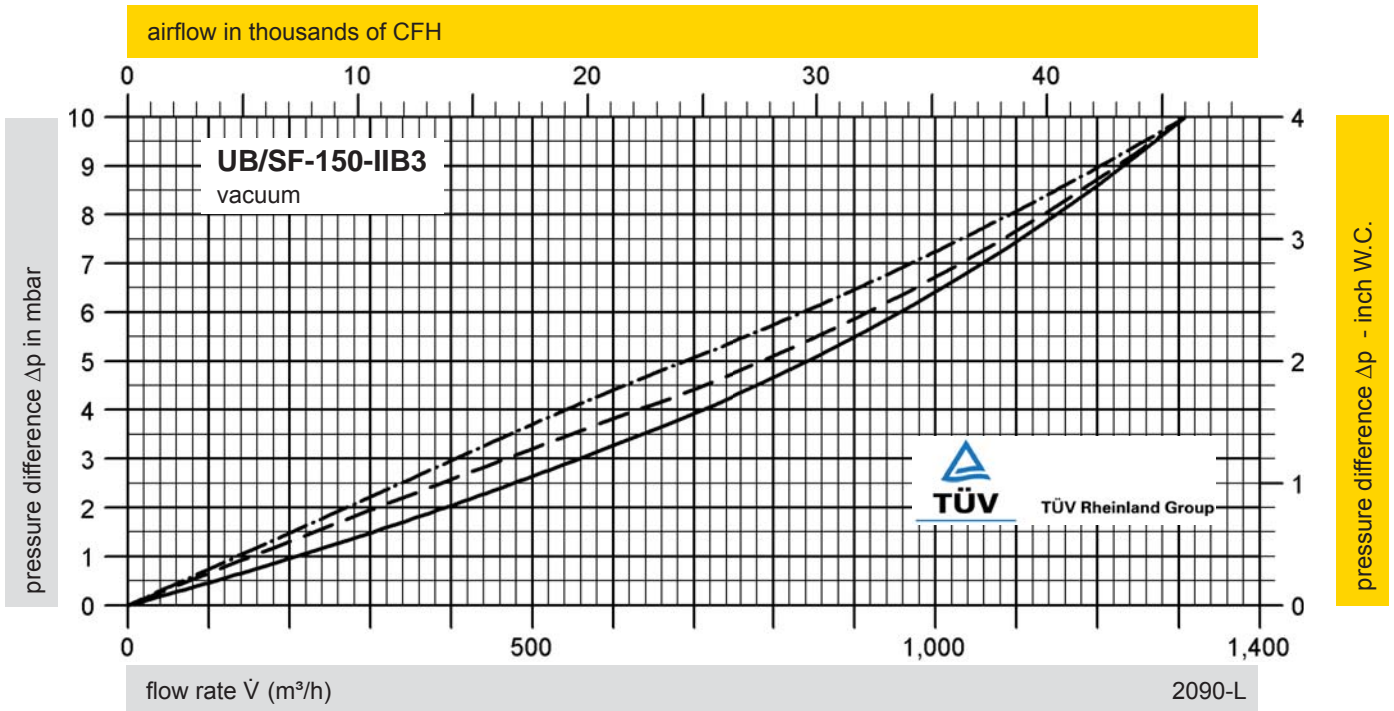

pressure difference = max. allowable tank design vacuum - valve set vacuum

adjusted set vacuum:

- ≤ -5 mbar / ≤ -2 inch W.C.
- - - - - > -5 mbar up to ≤ -7 mbar / > -2 inch W.C. up to ≤ -2.8 inch W.C.
- . - . - > -7 mbar up to ≤ -35 mbar / > -2.8 inch W.C. up to ≤ -14 inch W.C.

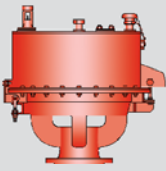

Pressure Diaphragm Valve

deflagration- and endurance burning-proof

PROTEGO® UB/DF

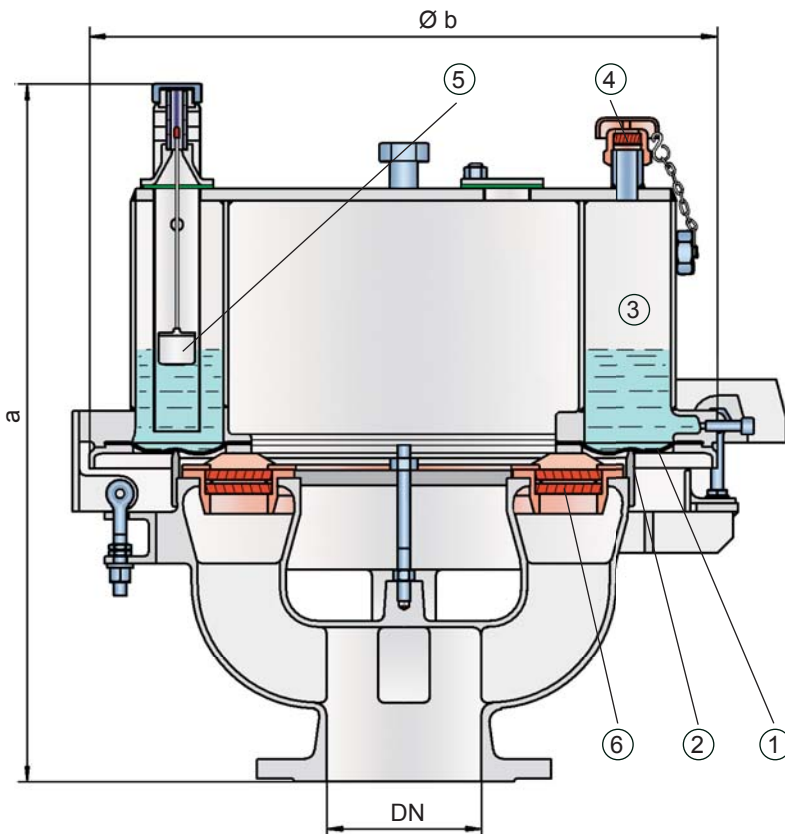

When the pressure in the tank reaches the set pressure, the diaphragm (1) on the outer valve seat ring (2) is lifted and vapors vent to the environment. The set pressure is adjusted by the liquid (water-glycol mixture) column height, which is filled into the outer ring chamber (3). The overpressure chamber is equipped with an opening (4) to keep the pressure in balance with the ambient pressure. The opening is equipped with a FLAMEFILTER® to avoid flame transmission into the overpressure chamber. Ambient air can now flow into the tank. The liquid column height which affect the set pressures is checked by a floating level indicator (5).

The tank pressure is maintained up to the set pressure with a tightness that is far superior to the conventional standard due to our highly developed manufacturing technology. This is achieved because the liquid loaded diaphragm presses tightly around the special designed valve seat surface area, even when the operating pressure increases. This is extremely important to reduce leakage to an absolute minimum. After the excess pressure is discharged, the valve reseats and provides a tight seal.

If the tank pressure exceeds the adjusted set pressure, explosive gas/product-vapour air mixtures exit. The speed at which these mixtures exit the annular gap between the diaphragm and the outer valve seat ring while overcoming the set pressure is much faster than the flame speed. If this mixture ignites, flashback into the tank is prevented. If the mixture flow continues, the dynamic flame arresting feature prevents flashback ignition even in the case of endurance burning. Even at relatively low flow rates, which occur during thermal outbreathing, the gap formed by the volumetric flow is so narrow that flames are extinguished in the gap and flashback is prevented. At very low pressure settings the explosion pressures resulting from an atmospheric deflagration may be strong enough to lift the diaphragm off the valve seat rings so that flashback could result. The ignition into the tank can be prevented by installing the PROTEGO® flame arrester unit (8). This flame arrester unit provides additional protection against atmospheric deflagration during regular maintenance and inspection.

The valve can be used up to an operating temperature of +60°C / 140°F and meets the requirements of European tank design standard EN 14015 – Appendix L and ISO 28300 (API 2000).

Type-approved in accordance with the current ATEX Directive and EN ISO 16852 as well as other international standards.

Pressure Settings:

DN 80	+3.5 mbar	up to +50 mbar
	+1.4 inch W.C.	up to +20 inch W.C.
DN 100	+3.5 mbar	up to +45 mbar
	+1.4 inch W.C.	up to +18 inch W.C.
DN 150	+3.5 mbar	up to +46 mbar
	+1.4 inch W.C.	up to +18.4 inch W.C.

Higher pressure settings up to +140 mbar (56.2 inch W.C.) in special design with additional liquid reservoir as well as lower pressure settings upon request.

Function and Description

The deflagration- and endurance burning-proof UB/DF type PROTEGO® diaphragm valve is a state-of-the-art pressure-relief valve combining the function of a dynamic and static flame arrester. Worldwide this design is unique. It is primarily used as a safety device for flame transmission proof out breathing on tanks, containers and process engineering apparatus. The valve offers reliable protection against excess pressure prevents the inbreathing of air and product losses almost up to the set pressure and protects against atmospheric deflagration and endurance burning if stabilized burning occurs. The PROTEGO® UB/DF diaphragm valve has proven its performance over many years in a great variety of severe applications in the petrochemical and chemical industry. The set pressure is adjusted with a freeze resistant water-glycol mixture, which assures safe operation under extreme cold weather conditions. The PROTEGO® UB/DF valve is available for substances of explosion group IIB3 (NEC group C MESG ≥ 0.65 mm).



Special Features and Advantages

- high performance seal reducing product loss below EPA's 500ppm rule preventing environmental pollution
- set pressure close to opening pressure enables optimum pressure maintenance in the system
- high flow capacity
- can be used as a protective system according to ATEX in areas subject to an explosion hazard
- protection against atmospheric deflagrations and endurance burning for products up to explosion group IIB3 (NEC group C ≥ 0.65 mm MESG)
- minimum pressure drop of the FLAMEFILTER®
- flame-transmission-proof pressure and vacuum chambers
- freeze protection at sub-zero conditions
- self draining function for condensate
- liquid column height is monitored by level indicators
- easy maintenance through hinged vent cap
- modular design enables individual FLAMEFILTER® discs and valve diaphragm to be replaced
- particularly suitable for problematic products such as styrene, acrylics, etc.

Design Types and Specifications

The diaphragm is pressurized by liquid. Higher pressures can be achieved upon request with a special liquid reservoir.

There are two different designs:

Pressure diaphragm valve, basic design **UB/DF -**

Pressure diaphragm valve with heating coil **UB/DF -**
(max. heating fluid temperature +85°C / 185°F)

In addition to the standard design, a series of specially developed designs, which are particularly suitable for the operating conditions to which these products are subjected, can be provided upon request (for example, for acrylics or styrene storage tanks, etc.).

Remark

$$\text{set pressure} = \frac{\text{opening pressure resp. tank design pressure}}{1,4}$$

Set pressure = the valve starts to open

Opening pressure = set pressure plus overpressure

Overpressure = pressure increase over the set pressure

Table 1: Dimensions

Dimensions in mm / inches

To select the nominal size (DN), please use the flow capacity charts on the following pages

DN	pressure	80 / 3"	100 / 4"	150 / 6"
a	up to +28 mbar / +11.2 inch W.C.	615 / 24.21	645 / 25.39	680 / 26.77
a	> +28 mbar / +11.2 inch W.C.	765 / 30.12	795 / 31.30	830 / 32.68
b		410 / 16.14	485 / 19.09	590 / 23.23

Pressure settings > +50 mbar / +20 inch W.C. (DN 80/3"), > +45 mbar / +18 inch W.C. (DN 100/4"), > +46 mbar / +18.4 inch W.C. (DN150/6") with additional liquid reservoir - dimensions upon request

Dimensions for pressure diaphragm valves with heating coil upon request

Table 2: Selection of explosion group

MESG	Expl. Gr. (IEC/CEN)	Gas Group (NEC)	Special approvals upon request
≥ 0,65 mm	IIB3	C	



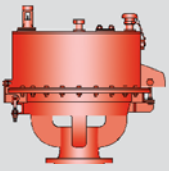

Pressure Diaphragm Valve

deflagration- and endurance burning-proof

PROTEGO® UB/DF

Table 3: Material selection for housing

Design	C	D
Housing	Steel	Stainless Steel
Valve top	Stainless Steel	Stainless Steel
Heating coil (UB/DF-H-...)	Stainless Steel	Stainless Steel
Valve seat	Stainless Steel	Stainless Steel
Gasket	FPM	PTFE
Diaphragm	A, B	A, B
Flame arrester unit	C	C

Option: Housing with ECTFE-lining
Special materials upon request



Coated Devices
(Flyer pdf)

Table 4: Material selection for diaphragm

Design	A	B
Diaphragm	FPM	FEP

Special materials upon request

Table 5: Material combinations of flame arrester unit

Design	C
FLAMEFILTER® cage	Stainless Steel
FLAMEFILTER®	Stainless Steel
Spacer	Stainless Steel

Special materials upon request

Table 6: Flange connection type

EN 1092-1; Form B1
ASME B16.5; 150 lbs RFSF

other types upon request

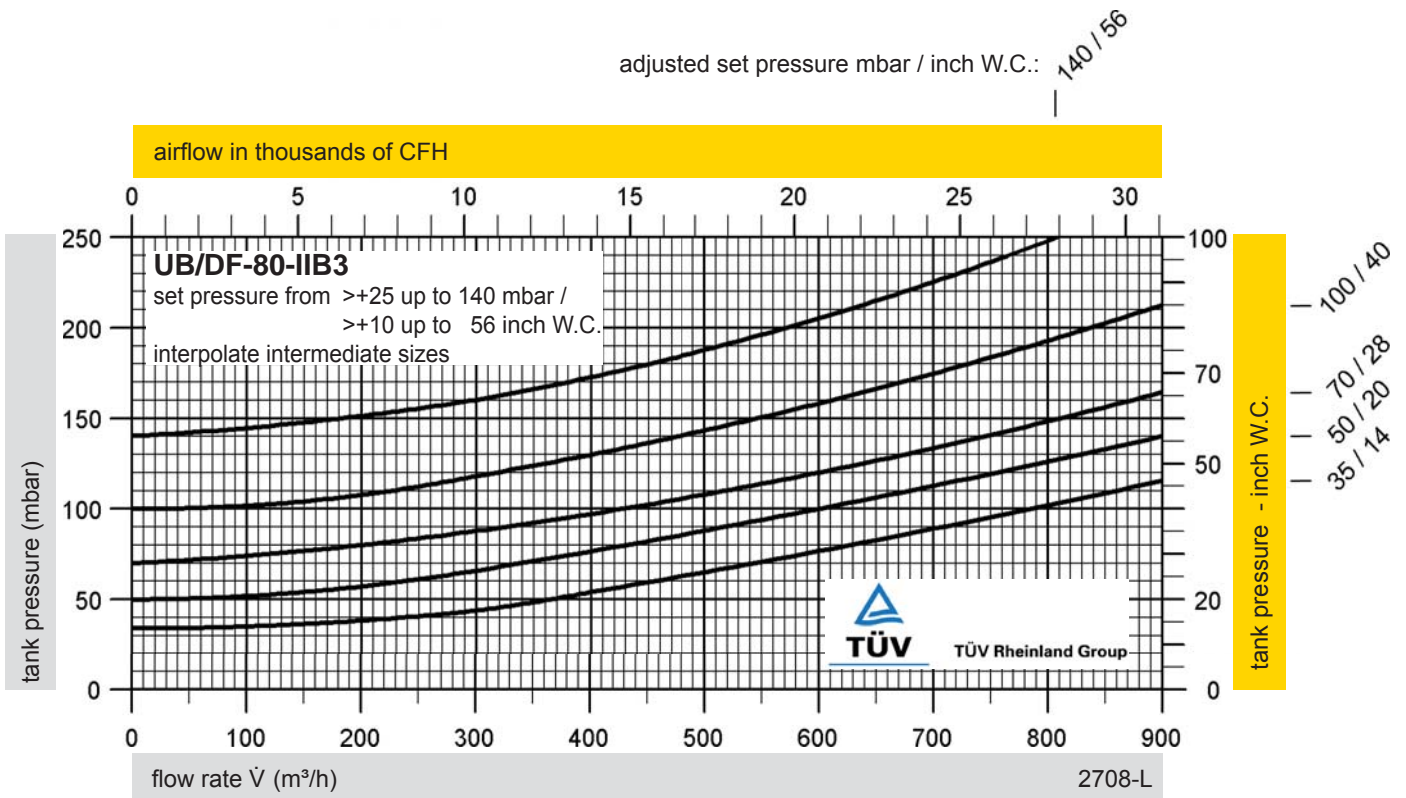
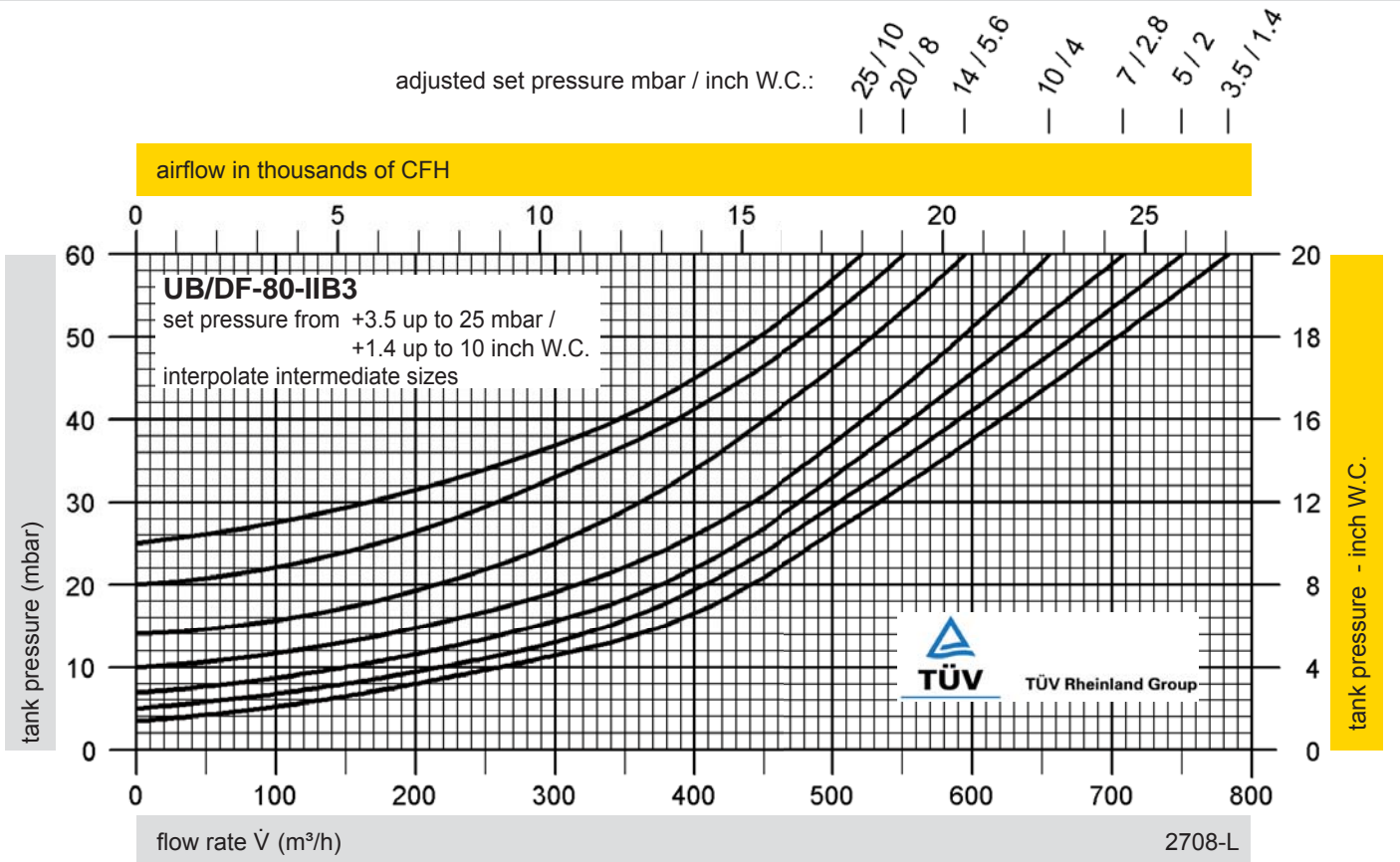

The flow capacity chart has been determined with a calibrated and TÜV certified flow capacity test rig.
 Volume flow \dot{V} in (m³/h) and CFH refer to the standard reference conditions of air ISO 6358 (20°C, 1bar).
 Conversion to other densities and temperatures refer to Vol. 1: "Technical Fundamentals".



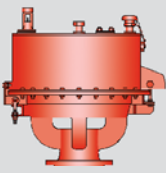

Pressure Diaphragm valve

Flow Capacity Charts

PROTEGO® UB/DF

adjusted set pressure mbar / inch W.C.: 25 / 10

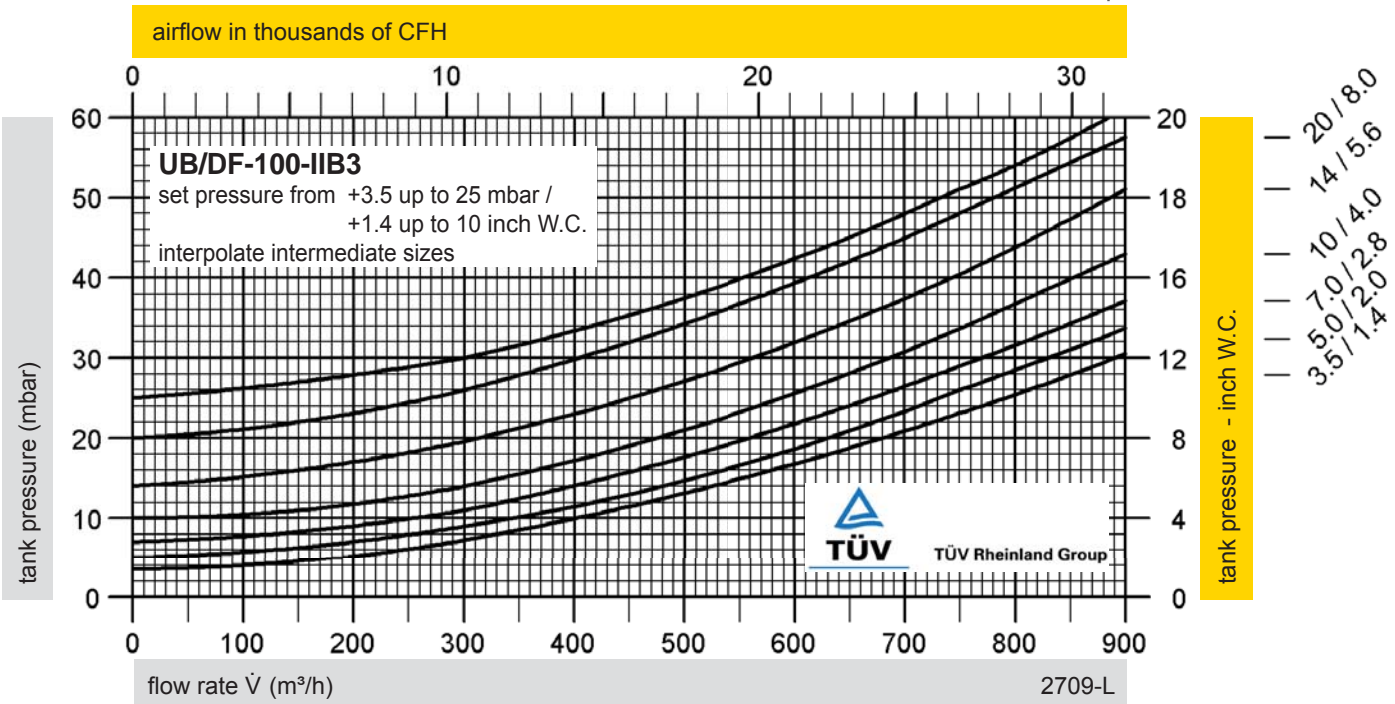

adjusted set pressure mbar / inch W.C.: 140 / 56

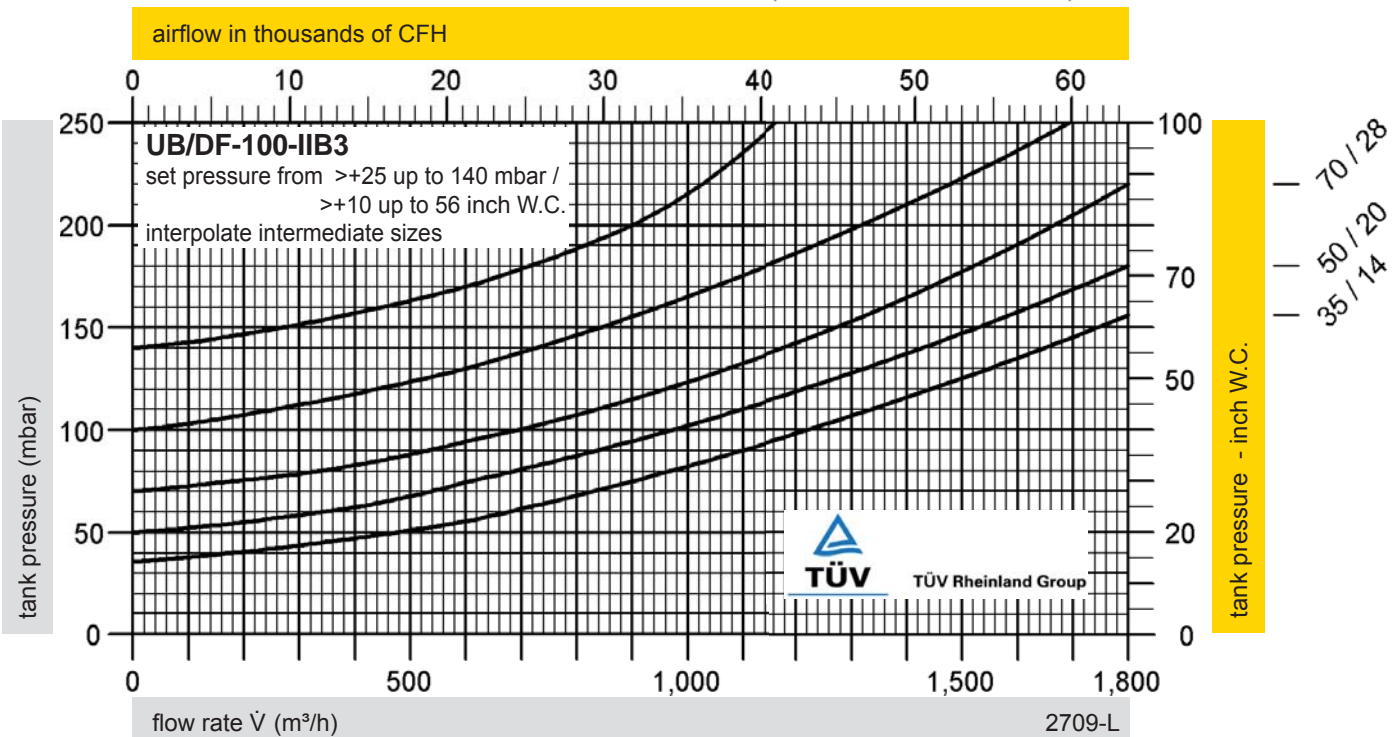

The flow capacity charts have been determined with a calibrated and TÜV certified flow capacity test rig. Volume flow \dot{V} in (m³/h) and CFH refer to the standard reference conditions of air ISO 6358 (20°C, 1bar). Conversion to other densities and temperatures refer to Vol. 1: "Technical Fundamentals".

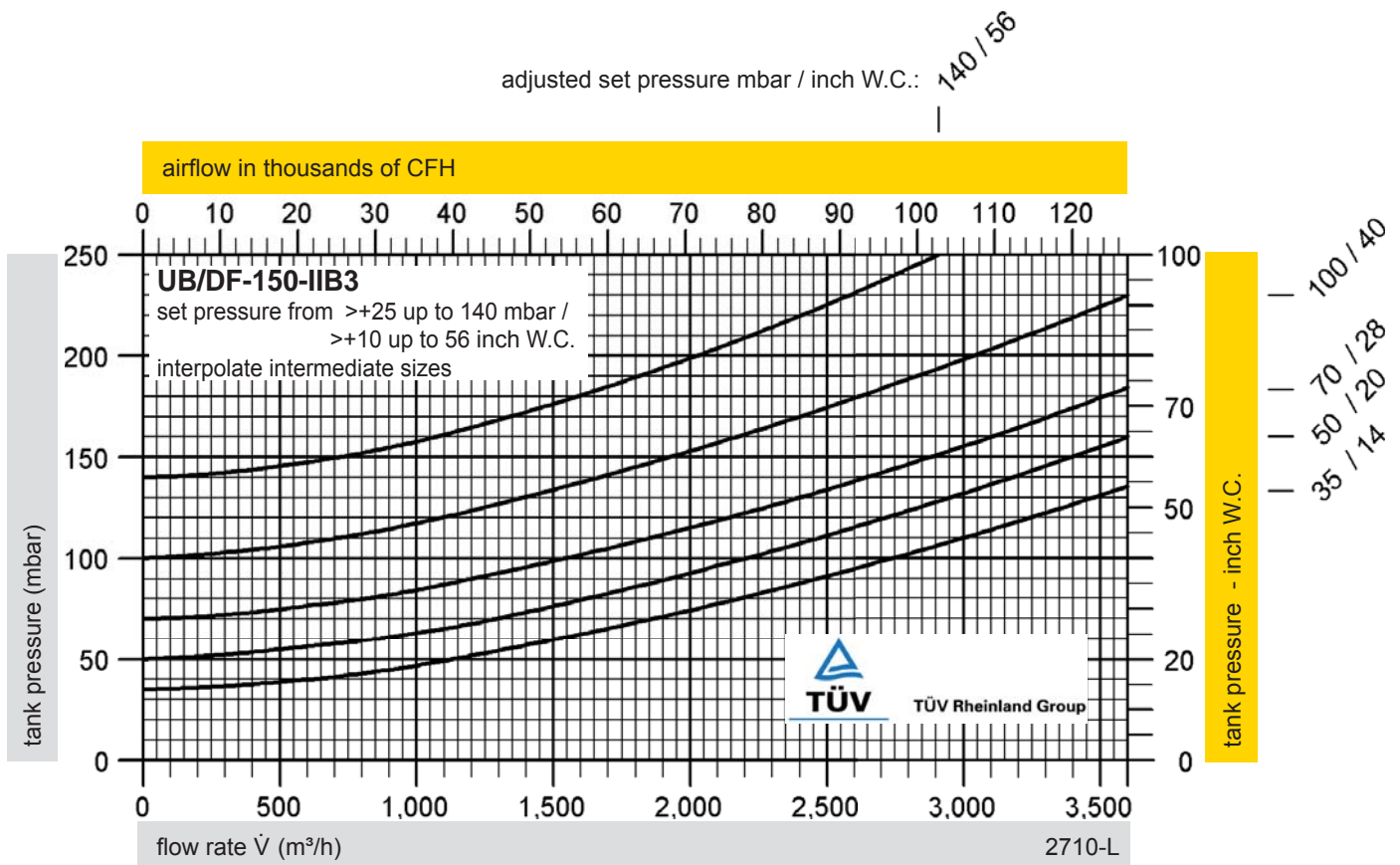
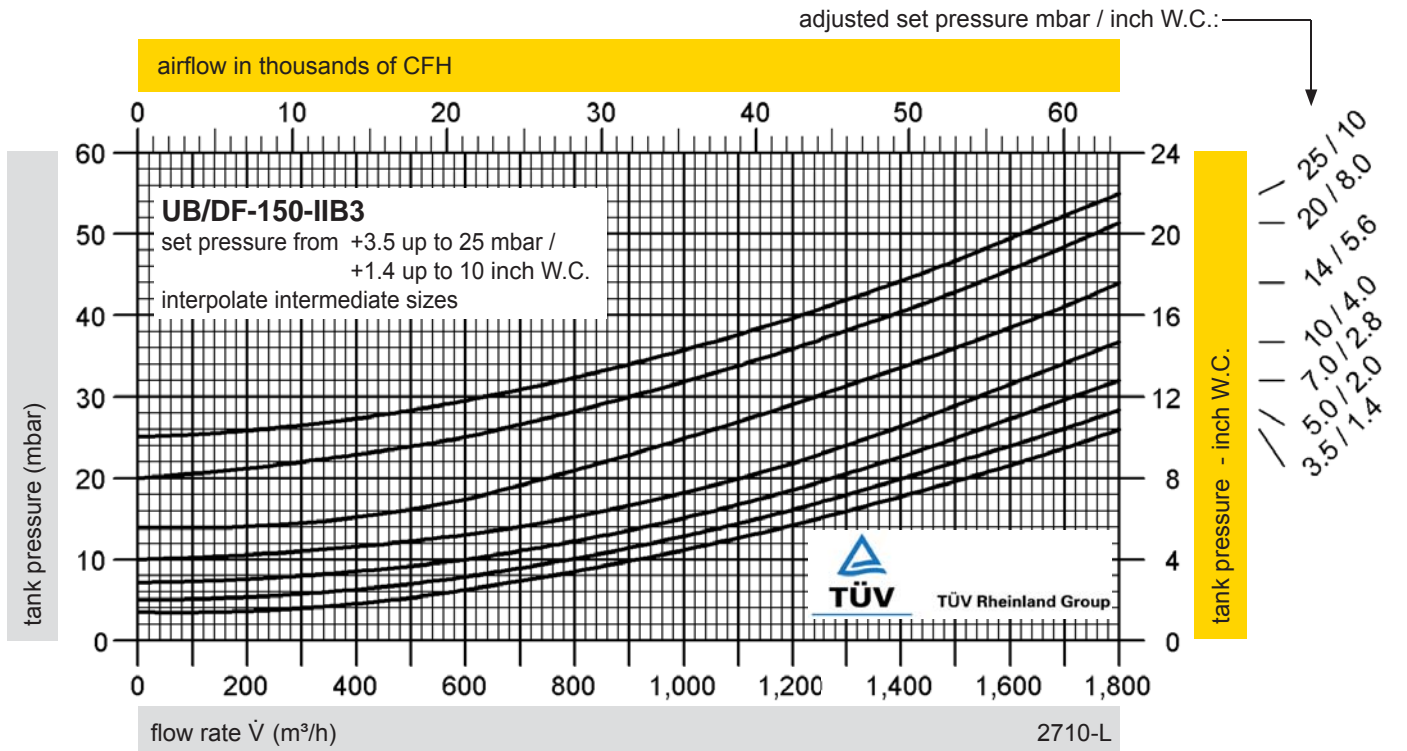

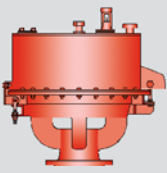

Vacuum Diaphragm Valve

deflagration-proof

PROTEGO® UB/VF

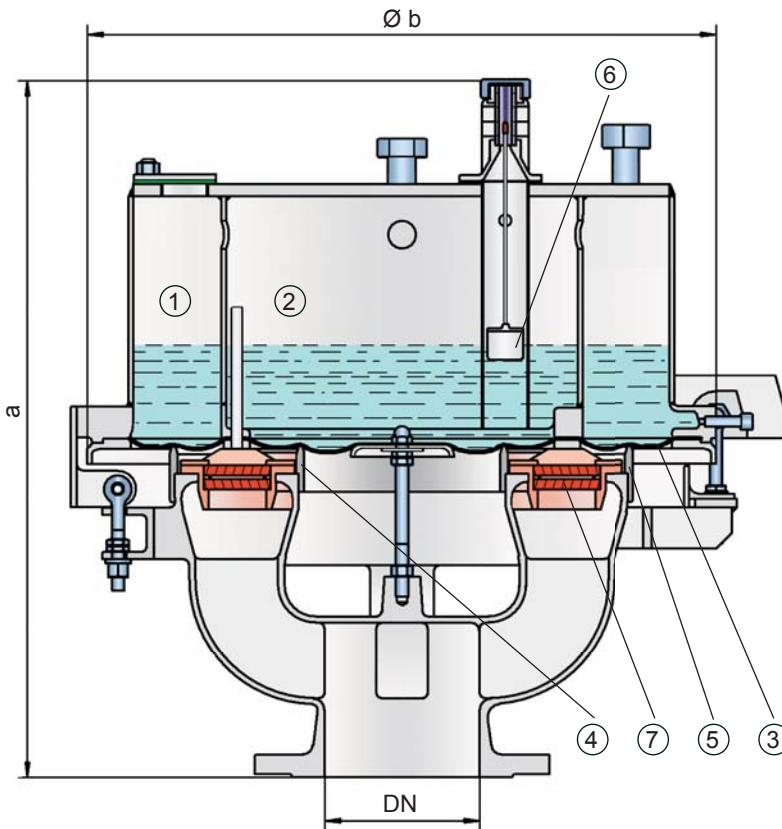

vacuum chamber, is reached the atmospheric pressure lifts the diaphragm (3) up off the inner and outer valve seat rings (4,5). Ambient air can now flow into the tank. The liquid column heights, which affect the set vacuum, can be checked by a floating level indicator (6).

The tank vacuum is maintained up to the set vacuum with a tightness that is far superior to the conventional standard due to our highly developed manufacturing technology. This is achieved because the liquid loaded diaphragm presses tightly around the special designed valve seat surface area, even when the operating vacuum increases. This is extremely important to reduce leakage to an absolute minimum. After the vacuum is balanced, the valve reseats and provides a tight seal.

At very low vacuum settings the explosion pressures resulting from an atmospheric deflagration may be strong enough to lift the diaphragm off the valve seat rings so that flashback could result. The ignition into the tank can be prevented by installing the PROTEGO® flame arrester unit (7). This flame arrester unit provides additional protection against atmospheric deflagration during regular maintenance and inspection.

The valve can be used up to an operating temperature of +60°C/ 140°F and meets the requirements of European tank design standard EN 14015 – Appendix L and ISO 28300 (API 2000).

Type-approved in accordance with the current ATEX Directive and EN ISO 16852 as well as other international standards.

Vacuum Settings: –3.5 mbar up to –35 mbar
–1.4 inch W.C. up to –14 inch W.C.
Higher and lower vacuum settings upon request

Function and Description

The deflagration-proof UB/VF type PROTEGO® diaphragm valve is a state-of-the-art vacuum relief valve combining the function of a dynamic and static flame arrester. Worldwide this design is unique. It is primarily used as a safety device for flame transmission proof inbreathing on tanks, containers and process engineering apparatus. The valve offers reliable protection against vacuum build up, prevents the inbreathing of air and product losses almost up to the set vacuum and protects against atmospheric deflagration. The PROTEGO® UB/VF diaphragm valve has proven its performance over many years in a great variety of severe applications in the petrochemical and chemical industry. Worldwide it is the only vent which functions in services such as styrene and acrylics. The set vacuum is adjusted with a freeze resistant water-glycol mixture, which assures safe operation under extreme cold weather conditions. The PROTEGO® UB/VF valve is available for substances from explosion group IIB3 (NEC group C MESH ≥ 0.65 mm).

If a vacuum builds up in the tank, it is transmitted through pressure balancing tubes into the vacuum chambers (1), (2). If the set vacuum, which depends on the liquid column height in the

Special Features and Advantages

- high performance seal reducing product loss below EPA's 500ppm rule preventing environmental pollution
- set vacuum close to the design vacuum enables optimum pressure maintenance in the system
- high flow capacity
- can be used as a protective system according to ATEX in areas subject to an explosion hazard
- protection against atmospheric deflagrations for products up to explosion group IIB3 (NEC group C MESH ≥ 0.65 mm)
- minimum pressure drop of the FLAMEFILTER®
- freeze protection at sub-zero conditions
- self draining function for condensate
- liquid column height is monitored by level indicators
- easy maintenance through hinged vent cap



- modular design enables individual FLAMEFILTER® discs and valve diaphragm to be replaced
- particularly suitable for problematic products such as styrene, acrylics, etc

Design Types and Specifications

The diaphragm is pressurized by liquid.

There are two different designs:

Vacuum diaphragm valve, basic design **UB/VF -**

Vacuum diaphragm valve with heating coil **UB/VF -**
(max. heating fluid temperature +85°C / 185°F)

In addition to the standard design, a series of specially developed designs, which are particularly suitable for the operating conditions to which these products are subjected, can be provided upon request (for example, for acrylics or styrene storage tanks, etc.).

Table 1: Dimensions

Dimensions in mm / inches

To select the nominal size (DN), please use the flow capacity charts on the following pages

DN	vacuum	80 / 3"	vacuum	100 / 4"	150 / 6"
a	up to -28 mbar / 11.2 inch W.C.	615 / 24.21	up to -22 mbar / 8.8 inch W.C.	645 / 25.39	680 / 26.77
a	< -28 mbar / 11.2 inch W.C.	765 / 31.12	< -22 mbar / 8.8 inch W.C.	795 / 31.30	830 / 32.68
b		410 / 16.14		485 / 19.09	590 / 23.23

Dimensions for vacuum diaphragm valve with heating coil upon request

Table 2: Selection of explosion group

MESG	Expl. Gr. (IEC/CEN)	Gas Group (NEC)	Special approvals upon request
≥ 0,65 mm	IIB3	C	

Table 3: Material selection for housing

Design	C	D	Option: Housing with ECTFE-lining Special materials upon request Coated Devices (Flyer pdf)
Housing	Steel	Stainless Steel	
Valve top	Stainless Steel	Stainless Steel	
Heating coil (UB/VF-H-...)	Stainless Steel	Stainless Steel	
Valve seat	Stainless Steel	Stainless Steel	
Gasket	FPM	PTFE	
Diaphragm	A, B	A, B	
Flame arrester unit	C	C	

Table 4: Material selection for diaphragm

Design	A	B	Special materials upon request
Diaphragm	FPM	FEP	

Table 5: Material combinations of flame arrester unit

Design	C	Special materials upon request
FLAMEFILTER® cage	Stainless Steel	
FLAMEFILTER®	Stainless Steel	
Spacer	Stainless Steel	

Table 6: Flange connection type

EN 1092-1; Form B1	other types upon request
ASME B16.5; 150 lbs RFSF	



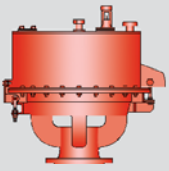

Vacuum Diaphragm Valve

Flow Capacity Charts

PROTEGO® UB/VF

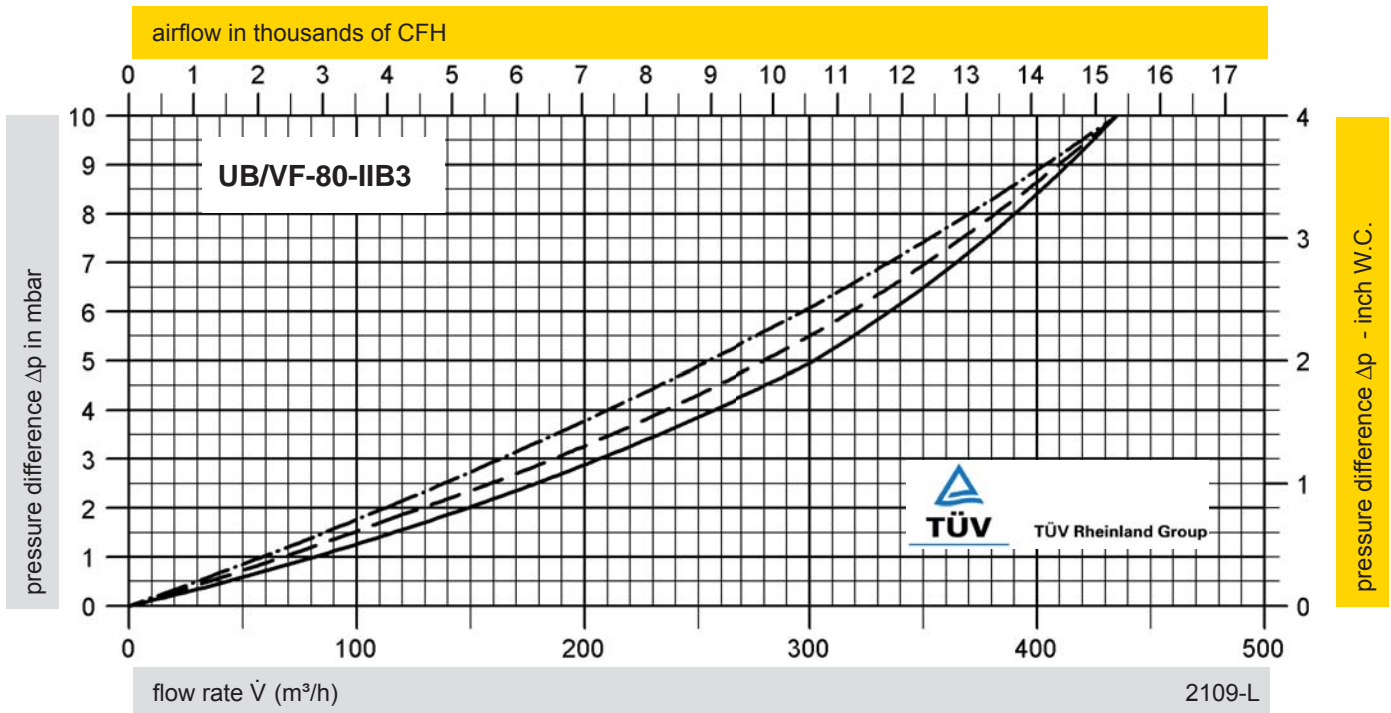

pressure difference = max. allowable tank design vacuum - valve set vacuum

adjusted set vacuum:

- ≤ -5 mbar / ≤ -2 inch W.C.
- - - > -5 mbar up to ≤ -7 mbar / > -2 inch W.C. up to ≤ -2.8 inch W.C.
- . - > -7 mbar up to ≤ -35 mbar / > -2.8 inch W.C. up to ≤ -14 inch W.C.

The flow capacity charts have been determined with a calibrated and TÜV certified flow capacity test rig. Volume flow \dot{V} in (m^3/h) and CFH refer to the standard reference conditions of air ISO 6358 (20°C, 1bar). Conversion to other densities and temperatures refer to Vol. 1: "Technical Fundamentals".

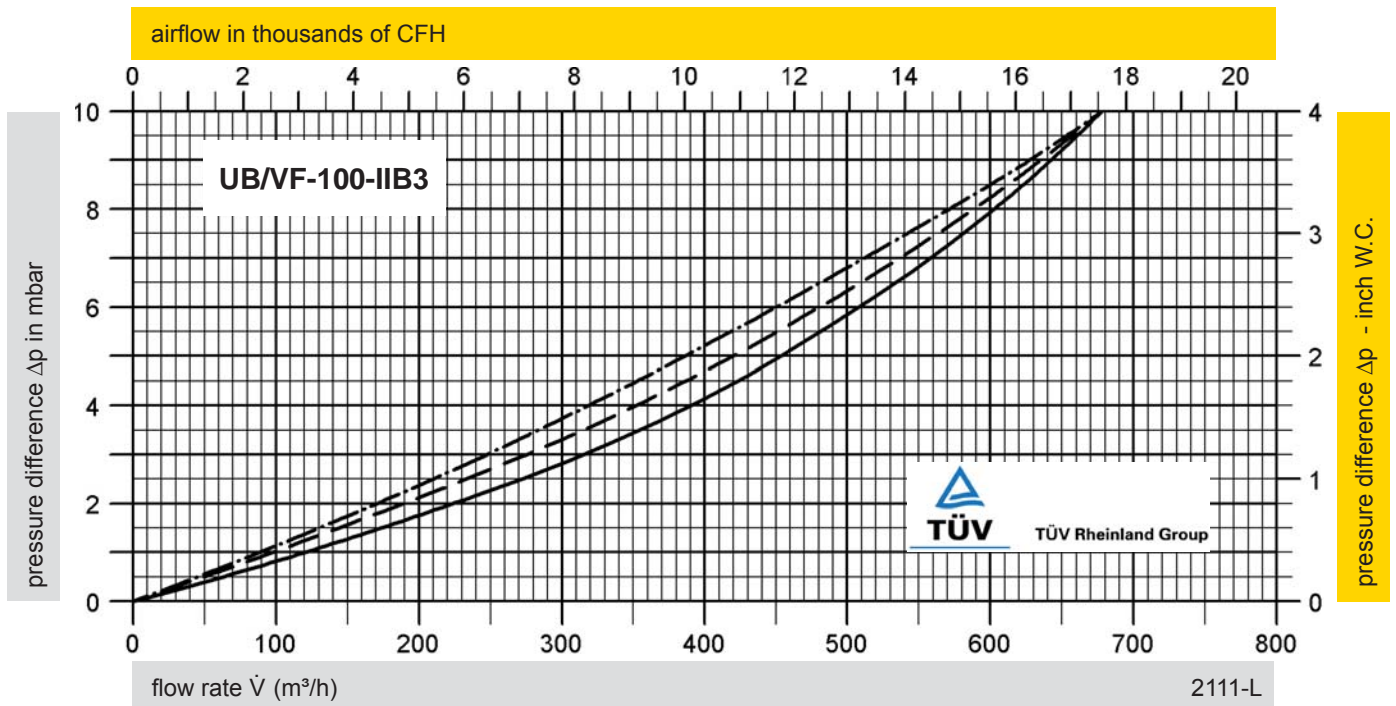

pressure difference = max. allowable tank design vacuum - valve set vacuum

adjusted set vacuum:

- ≤ -5 mbar / ≤ -2 inch W.C.
- - - - - > -5 mbar up to ≤ -7 mbar / > -2 inch W.C. up to ≤ -2.8 inch W.C.
- · - · - > -7 mbar up to ≤ -35 mbar / > -2.8 inch W.C. up to ≤ -14 inch W.C.

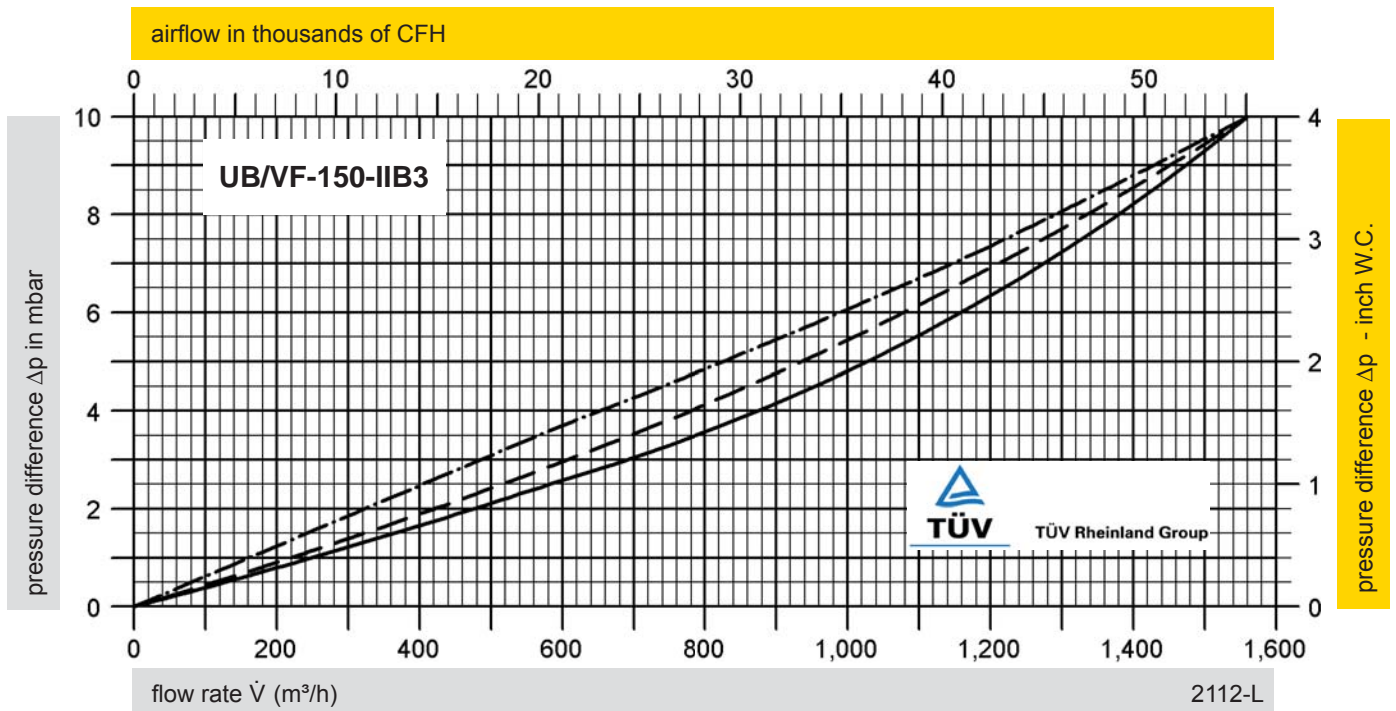

www.protego.com



for safety and environment

PROTEGO® Tank Accessories and Special Equipment

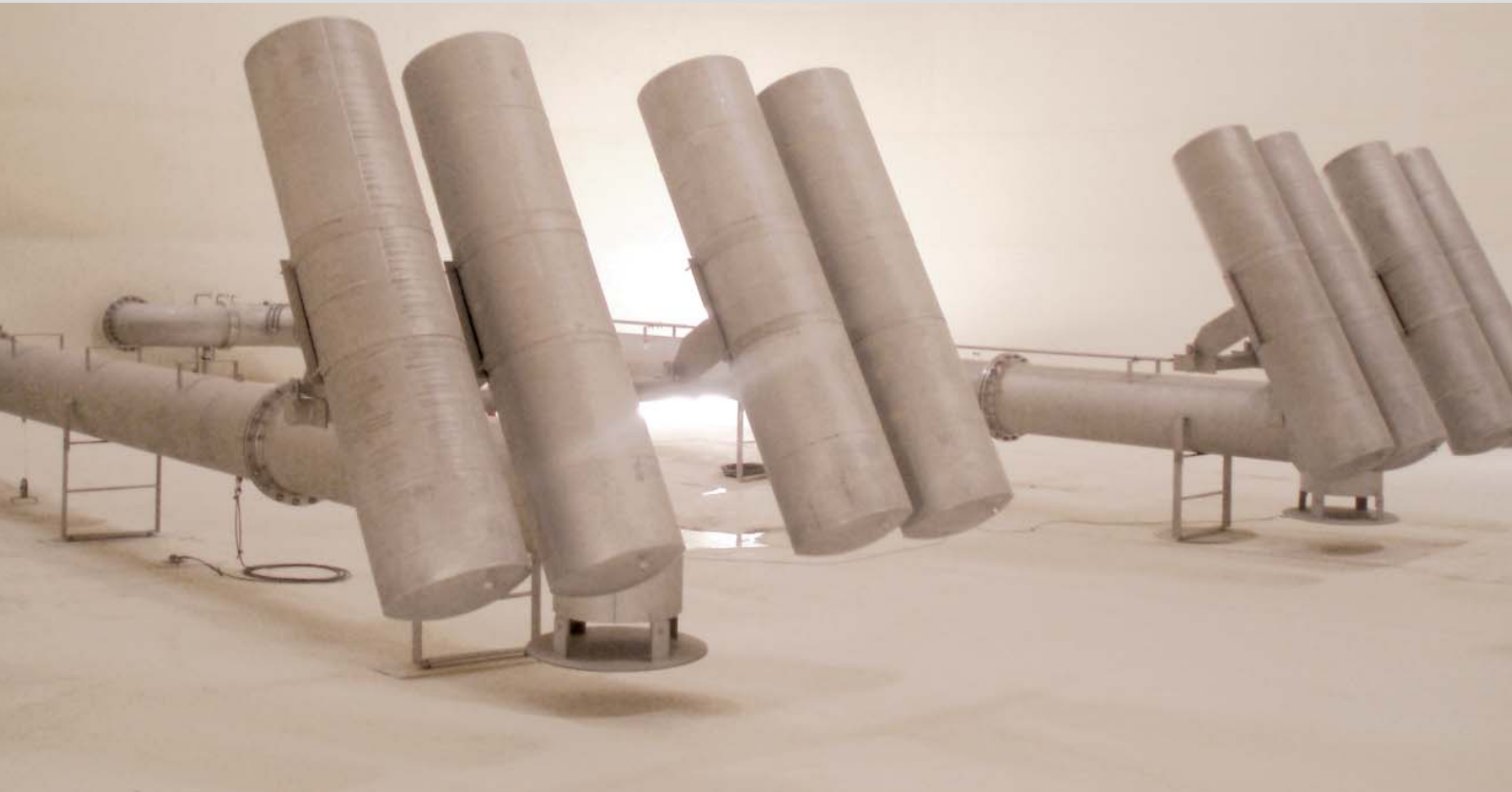

Volume 8

Volume 8

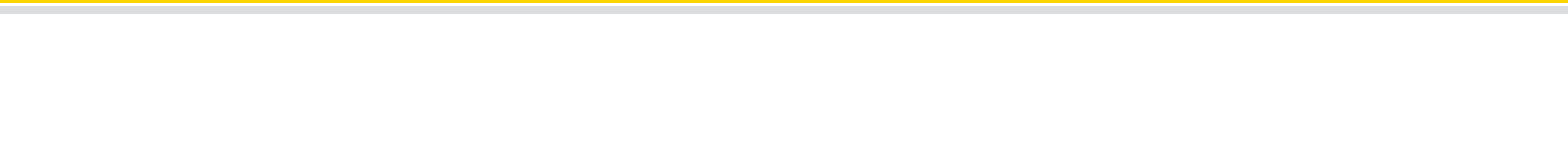
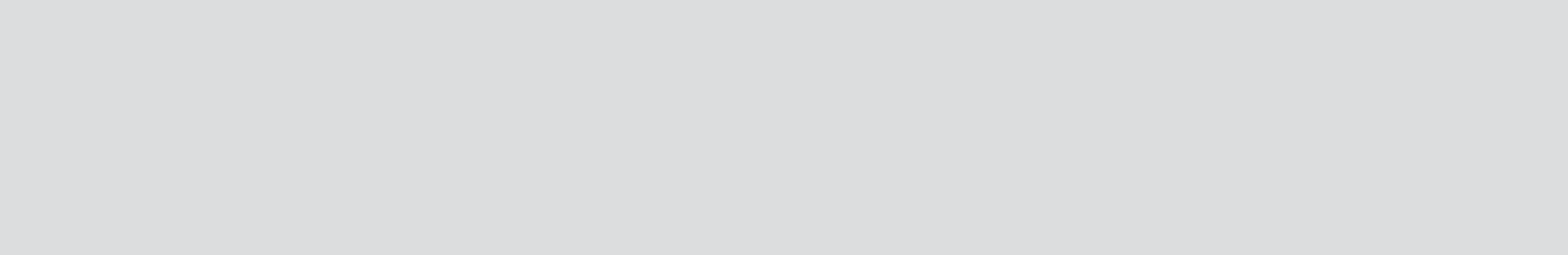



Tanks in tank farms and large vessels not only need to be equipped with flame arresters or pressure and vacuum valves but; in addition they need special equipment, which similar meets high requirements to operate safely.

Special Valves with Safety Functions

For emergency shut-off or for extraordinary operating conditions it is necessary to provide **internal safety valves** so that product leakage can be prevented quickly after a pipe burst.

Gauging and Sampling Equipment

Gauge and sampling hatches allow the use of **gauging and sampling devices** in the tank. For horizontal tanks deflagration proof gauging pipes are available.

For sampling and local venting in tanks that store flammable liquids PROTEGO® has designed special sampling and air bleed valves with flame arrester elements.

Explosion-proof floor drains for heliports pass flammable liquids (such as Kerosene) into catch tanks and prevent ignition inside. If an outside ignition source ignites the explosive atmosphere there is no flame transmission.

Floating Suction Units and Skimming Systems

Floating Suction Units PROTEGO® SA/S are designed to ensure that product in a storage tank is drawn off just below the surface of the liquid where it is cleanest.

Fixed roof tanks that store liquids with different density, so-called slop tanks, are fitted with the Float-Operated Skimming System PROTEGO® SA/DA for separating the phases.

Together with the tank operator or tank contractor we develop the best way to ensure both economical and safe operation.

Floating Roof Tank Equipment

For floating roof tanks the **drainage system for the floating roof** must be designed very precisely. Every movement of the floating roof must be taken into account and the load on the joints must not affect the free moving space. In case of restricted movement the system will crack, the pipes will bend and the joints will be stuck. In order to prevent the water in the system from standing and freezing, ensure sufficient drain to the lateral tank nozzle. Many years of experience are incorporated in the supplied systems that work without disruptions – starting from the **roof drain valves** to the systems with ball bearing joints or metal hose joints. With lowered floating roofs in maintenance positions the completely drained space below the floating roof must be vented through a **lift-actuated vent valve**. When storing flammable liquids in the tank venting is to be done through flame arresters.

Special Equipment

Hygroscopic products must be vented with dry air when stored. **Air-drying devices** with drying pearls prevent the air from saturating with humidity.

A special safety device is the **hydraulic flame arrester**. It is a collection device for large volume flows in pipelines collecting exhaust air from various plant areas, and it also functions as a backflow prevention device as it prevents the exchange of vapours. With extremely low pressure losses thanks to its relatively large drill holes in the sparge pipes the hydraulic flame arrester is insusceptible to clogging and therefore provides high plant availability. It can be used as flame arrester with substances of all explosion groups and provides protection against all types of combustion. The hydraulic flame arrester has to be monitored and controlled by instrumentation. Early involvement of our engineers in plant design is necessary to make the right selection.











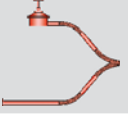
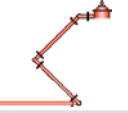
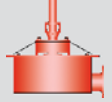
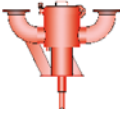

Selection







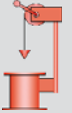

The special valves, systems and devices are designed together with the operator, engineering company and tank contractor. PROTEGO® prepares a quotation based on the detailed system specifications.



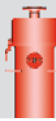

PROTEGO® Tank Accessories and Special Equipment

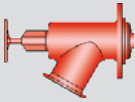
	Type	Size	Description	Page
Floating Suction Unit				
	SA/S		Floating Suction Unit	378 - 379
	SA/DA		Floating Skimmer System	380 - 381
Floating Roof Tank Equipment				
	SE/K	80 - 100 3" - 4"	Floating Roof Drainage System with Metal Hose Joint	382 - 383
	SE/CK	80 - 150 3" - 6"	Floating Roof Drainage System with Swivel Joints	384 - 385
	D/SR D/SR-W	80 - 150 3" - 6"	Roof Drain Valves	386 - 387
	AL/DK AL 200	200 8"	Vent Valve, Lift-actuated	388 - 390
Gauging and Sampling Equipment				
	PF/K PF/TK PS/KF	100 - 200 4" - 8"	Gauge Hatch with flange	392 - 393
	PS/K PS/TK	100 - 200 4" - 8"	Gauge Hatch with welded nozzle	394 - 395
	PU-IIA	25 - 50 1" - 2"	Gauging Pipe, deflagration proof	 
	PR/0	25 - 150 1" - 6"	Gauging and Sampling Pipe, verifiable	 
	VP/HK with PS/E und PG/H	100 - 150 4" - 6"	Gauging and Sampling Device with accessories	 

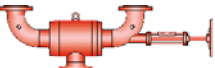
	Type	Size	Description	Page
Deflagration proof Special Valves				
	ZE/WU	15 - 25 G½" - G1"	Sampling and Air Bleed Valve, deflagration proof	396 - 397
	ZE/TK	15 - 25 G½" - G1"	Condensate Drain Valve, deflagration proof	398 - 399
Air-Drying Devices				
	LA	50 - 150 2" - 6"	Air-Drying Device	
	LA/V	50 - 150 2" - 6"	Air-Drying Device with Check Valve	
In-Tank Valve				
	SI/F	50 - 200 2" - 8"	Internal Safety Valve	400 - 401
	NB/AP	→ Volume 9	NEW	422 - 423
	SI/DP	→ Volume 9	NEW	424 - 425
	WV/T	→ Volume 9	NEW	420 - 421



Floating Suction Unit

PROTEGO® SA/S

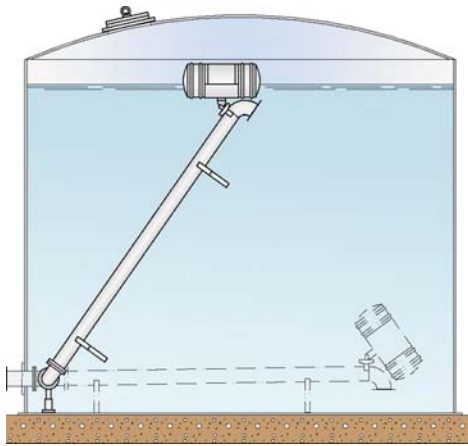

PROTEGO® SA/S for fixed roof tanks

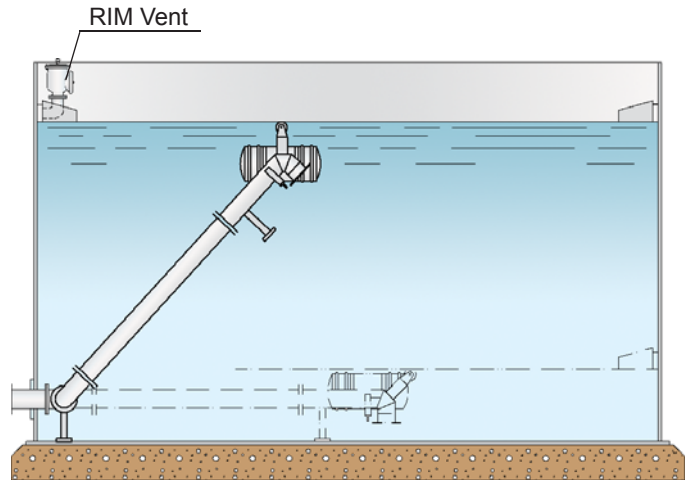

PROTEGO® SA/S for floating roof tanks

Function and Description

PROTEGO® Floating Suction Units - FSU - are designed to ensure that product in a storage tank is drawn off just below the surface of the liquid where it is cleanest, preventing the suction point being at the bottom of the tank where water and residuals will settle down.

Design Types and Specifications

PROTEGO® Floating Suction Units are designed and sized to suit the individual tank specifications and customer requirements.

PROTEGO® Floating Suction Units are designed for a long life in service. We use carbon steel or stainless steel for highly loaded components or aggressive media.

Solutions are available from 1" to 36" for horizontal or vertical tanks with fixed or floating roofs. Custom designs for unusual stored products are available.

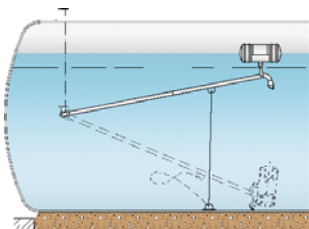

PROTEGO® SA/S for horizontal tanks

Selection and Design

PROTEGO® Floating Suction Units offer experienced technology for a complete solution for the end-user. This includes easy installation and assembly and full documentation with an arrangement drawing showing the FSU placed in the tank with regards to all internals.

Essential for the design of the PROTEGO® Floating Suction Unit is the Heavy Duty Swivel Joint which fulfils the requirement for an in-service installation to avoid high costs of repairs and to extend the tank maintenance to the planned interval.

The Swivel Joint comes with/in

- a sturdy design made of carbon or stainless steel
- maintenance-free greased for a life-time with aviation approved grease
- large sized ball bearings with two races to cover all side-flow forces during operation.

PROTEGO® Floating Suction Units have an intake designed to avoid any forming of vortex. The intake is able to release trapped air.

Floats are all made of stainless steel and are 100 % pressure tested.

Options upon request:

- Sampling pipes
- Function indicator
- Stress calculation due to liquid movement
- On-site support

PROTEGO® Floating Suction Units are „Made in Germany“ and will provide many years of trouble free tank operation.

*Project:
Location:
Client:
*Enduser:
*Engineering:

Tank Main Details

*Fixed roof tank <input type="checkbox"/>	*Fixed roof tank with internal floating roof <input type="checkbox"/>	
*Floating roof tank <input type="checkbox"/>		
*Horizontal tank <input type="checkbox"/>		
Tank-No.:	*Tank height: mm	*Tank diameter: mm
*Maximum filling height: mm		
*Material request of floating suction unit:		

Product details

*Stored product:	
*Product specific gravity:	
Maximum product temperature: °C	

Tank details

*Suction line size: DN		
*Shell nozzle centreline height / inwards projection:	mm	
*Manhole size: DN		
Bottom slope: <input type="checkbox"/>	Slope direction:	
*Are there any obstructions? (columns, heating coils,...) <input type="checkbox"/>	if <input type="checkbox"/> - please specify	
*Tank drawing / sketch? <input type="checkbox"/>	if <input type="checkbox"/> - specify request	

* This information must be indicated on request!
Fill in and tick off, if applicable.



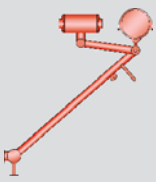

Floating Skimmer System

PROTEGO® SA/DA

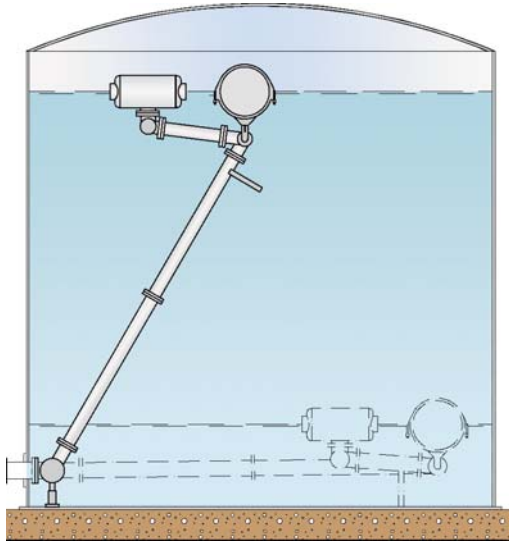

PROTEGO® SA/DA for fixed roof tanks

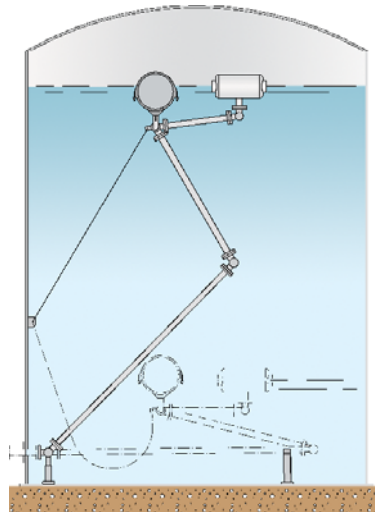

PROTEGO® SA/DA with double-bend for fixed roof tanks

Function and Description

Fixed roof tanks that store liquids with different density these so-called slop tanks are fitted with the Floating Skimmer System PROTEGO® SA/DA for separating the phases. The design of the skimmer results from different densities. They are developed to draw off the product with lower specific weight from the surface of the stored medium.

Design Types and Specifications

PROTEGO® SA/DA Floating Skimmer Systems are designed and sized to suit the individual tank specifications and the stored medium as well as customer requirements.

PROTEGO® SA/DA Floating Skimmer Systems are designed for a long life in service in complete medium contact.

We use carbon steel or stainless steel for highly loaded components or aggressive media.

Solutions are available from 2" to 6" for tanks with fixed roofs.

Selection and Design

PROTEGO® Floating Skimmer Systems offer experienced technology for a complete solution for the end-user. This includes easy installation and assembly of the system in the tank and full documentation with an arrangement drawing showing the Floating Skimmer System placed in the tank with regards to all internals.

Essential for the design of the PROTEGO® Floating Skimmer Systems is the Heavy Duty Swivel Joint which fulfils the requirement for an in-service installation to avoid high costs of repairs and to extend the tank maintenance to the planned interval.

The Swivel Joint comes with/in

- a sturdy design made of carbon or stainless steel
- maintenance-free greased for a life-time with aviation approved grease
- large sized ball bearings with two races to cover all side-flow forces during operation.

PROTEGO® Floating Skimmer Systems SA/DA are fitted with a separate skimming float that is just responsible for separating the different phases. The weight of the complete system is floated by one or more floats.

Floats are always made of stainless steel and are 100 % pressure tested.

PROTEGO® Floating Skimmer Systems are „Made in Germany“ and will provide many years of trouble free tank operation.

*Project:
Location:
Client:
*Enduser:
*Engineering:

Tank Main Details

*Fixed roof tank	<input type="checkbox"/>	
Tank No.:	*Tank height: :	mm *Tank diameter: mm
*Maximum filling height:	mm	
*Material request of Skimming Systems:		

Product Details

*Stored liquid:	Specific gravity:
*Sucked in liquid:	Specific gravity:
Maximum product temperature:	°C

Tank Details

*Skimming System size: DN	
*Shell nozzle centreline height / inwards projection	mm
*Manhole size: DN	
Bottom slope:	<input type="checkbox"/> Slope direction:
*Are there any obstructions? (columns, heating coils,...)	<input type="checkbox"/> if <input type="checkbox"/> - please specify
*Tank drawing / sketch	<input type="checkbox"/> if <input type="checkbox"/> - specify request

* This information must be indicated on request!
Fill in and tick off, if applicable.



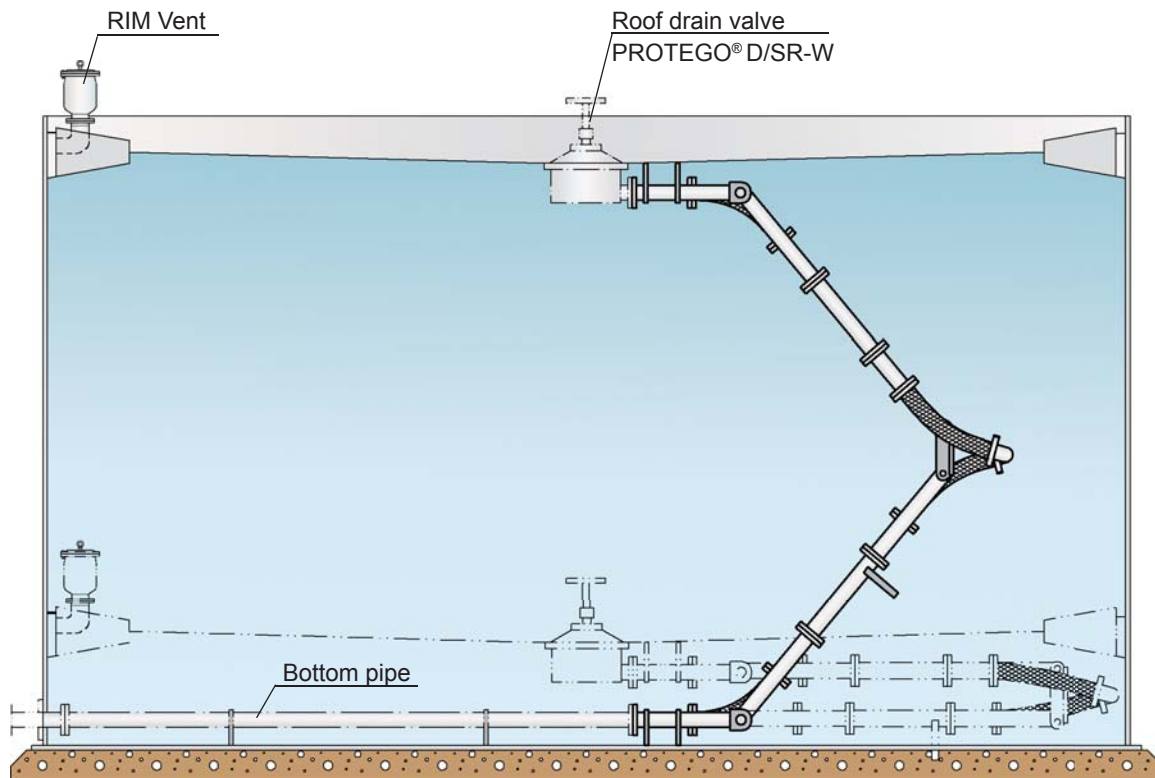
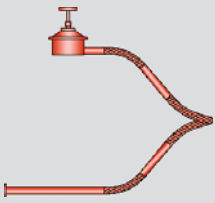

Function and Description

Floating roof tanks require a drainage system that automatically drains the accumulating rainwater off the floating roof. PROTEGO® SE/K is a single scissor-pipe-system that works with robust shackle joints. The water is drained by unstressed mounted and pressure resistant metal hoses.

The upper scissor pipe is connected to the roof drain valve and the lower scissor pipe is connected to the bottom pipe. Via the operational opened roof drain valve the water is transferred by the drainage system out of the tank.

Design Types and Specifications

PROTEGO® floating roof drainage systems are designed and sized to suit the individual tank specifications and customer requirements.

PROTEGO® floating roof drainage systems are designed for a long life in service. We use only carbon steel or stainless steel as the material of construction. For the carbon steel version the joint bearings are made of stainless steel.

Solutions are available from 3" to 8" for floating roof tanks with external floating roof.

PROTEGO® Floating Roof Drainage Systems are „Made in Germany“ and will provide many years of trouble free tank operation.

Selection and Design

PROTEGO® Floating Roof Drainage Systems offer experienced technology for a complete solution for the end-user. This includes easy installation and assembly and full documentation with an arrangement drawing showing the Floating Roof Drainage System placed in the tank with regards to all internals.

The flexibility of the metal hose is realized by the shackle-bolted joint. Forces that may occur due to torsion or uneven movements of the floating roof are absorbed through design and arrangement of the joints and thus have no negative effects on the system or metal hoses. The water is drained by metal hoses that are directly connected to the scissor pipes. The drain water does not pass through the actual joints and therefore sealing elements as used for common swivel joint systems are not required.

For stability reasons metal hose joints are made of steel or stainless steel.

Options upon request:

- Roof drain valve
- Bottom pipe
- On-site support

*Project:
Location:
Client:
*Enduser:
*Engineering:

Tank Main Details

*Floating roof tank	<input type="checkbox"/>	
Tank No.:	*Tank height: :	mm *Tank diameter: mm
*Maximum filling height:	mm	
* Material request of Floating Roof Drainage System:		

Product Details

*Product stored:	
*Specific gravity:	
Maximum product temperature:	°C

Tank Details

*Nominal diameter of drain line: DN	
*Shell nozzle centreline height / inwards projection	mm
*Manhole size: DN	
Bottom slope:	<input type="checkbox"/> Slope direction:
*Are there any obstructions? (columns, heating coils,...)	<input type="checkbox"/> if <input type="checkbox"/> - please specify
*Tank drawing / sketch	<input type="checkbox"/> if <input type="checkbox"/> - please specify

* This information must be indicated on request!
Fill in and tick off, if applicable.

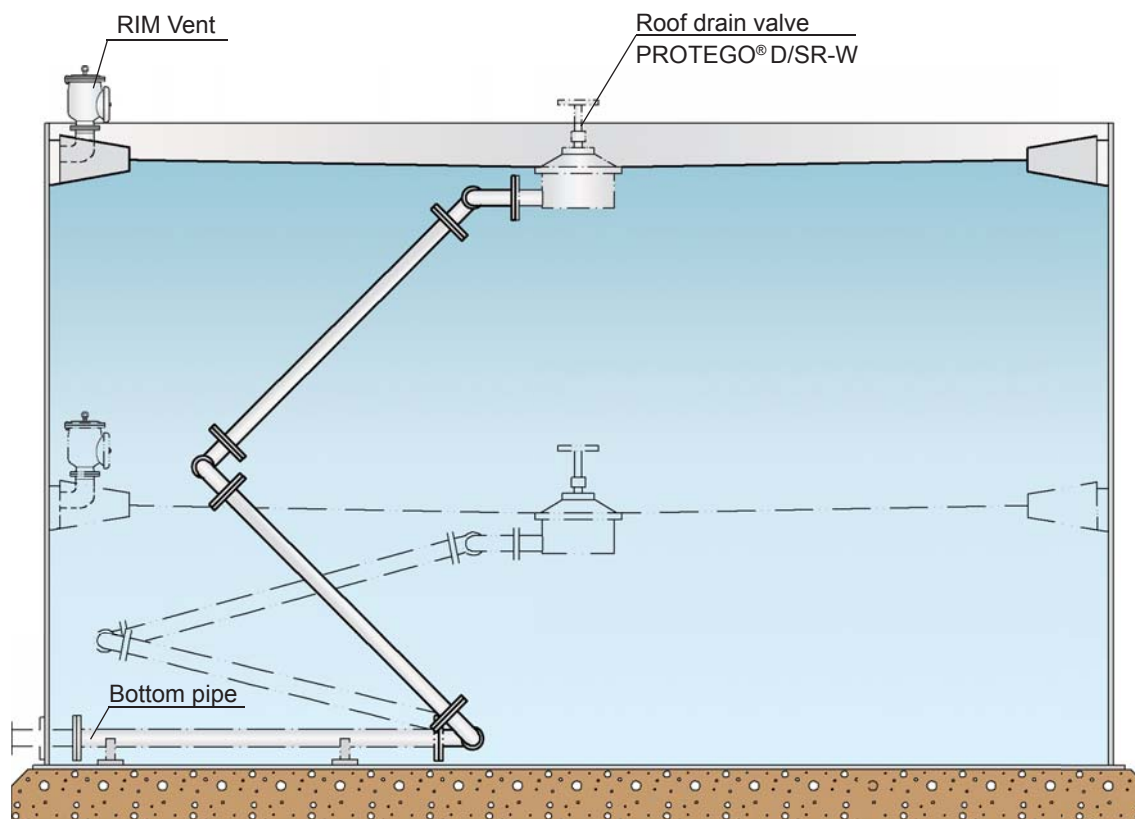
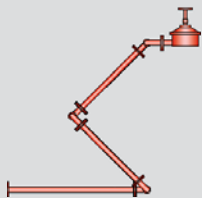

Function and Description

Floating roof tanks require a drainage system that automatically drains the accumulating rainwater off the floating roof. PROTEGO® SE/CK is a single scissor-pipe-system that works with swivel joints.

The upper scissor pipe is connected to the roof drain valve, the lower scissor pipe is connected to the bottom pipe. Via the operational opened roof drain valve the water is transferred by the drainage system out of the tank.

Design Types and Specifications

PROTEGO® floating roof drainage systems are designed and sized to suit the individual tank specifications and customer requirements.

PROTEGO® floating roof drainage systems are designed for a long life in service. We use carbon steel or stainless steel for highly loaded components or aggressive media.

Solutions are available from DN 80/3" to DN 200/8" for floating roof tanks with external floating roof.

Selection and Design

PROTEGO® Floating Roof Drainage Systems offer experienced technology for a complete solution for the end-user. This includes easy installation and assembly and full documentation with an arrangement drawing showing the Floating Roof Drainage System placed in the tank with regards to all internals.

Essential for the design of the PROTEGO® Floating Roof Drainage System is the Heavy Duty Swivel Joint which fulfils the requirement for an in-service installation to avoid high costs of repairs and to extend the tank maintenance to the planned interval.

The Swivel Joint comes with/in

- a sturdy design made of carbon or stainless steel
- maintenance-free greased for a life-time with aviation approved grease
- large sized ball bearing with two races to cover all side-flow forces during operation.

Options upon request:

- Roof drain valve
- Bottom pipes
- On-site support

PROTEGO® Floating Roof Drainage Systems are „Made in Germany“ and will provide many years of trouble free tank operation.

*Project:
Location:
Client:
*Enduser:
*Engineering:

Tank Main Details

*Floating roof tank	<input type="checkbox"/>	
Tank No.:	*Tank height: :	mm *Tank diameter: mm
*Maximum filling height:	mm	
* Material request of Floating Roof Drainage System:		

Product Details

*Product stored:	
*Specific gravity:	
Maximum product temperature:	°C

Tank Details

*Nominal diameter of drain line: DN	
*Shell nozzle centreline height / inwards projection	mm
*Manhole size: DN	
Bottom slope:	<input type="checkbox"/>
Slope direction:	
*Are there any obstructions? (columns, heating coils,...)	<input type="checkbox"/>
	if <input type="checkbox"/> - please specify
*Tank drawing / sketch	<input type="checkbox"/>
	if <input type="checkbox"/> - please specify

* This information must be indicated on request!
Fill in and tick off, if applicable.

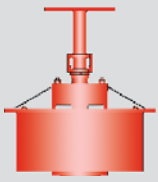

Roof Drain Valves



PROTEGO® D/SR and D/SR-W

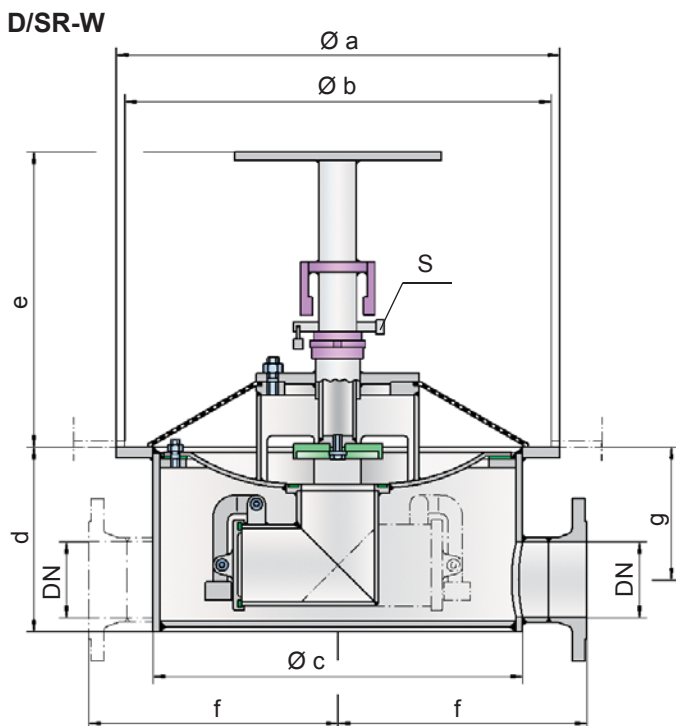
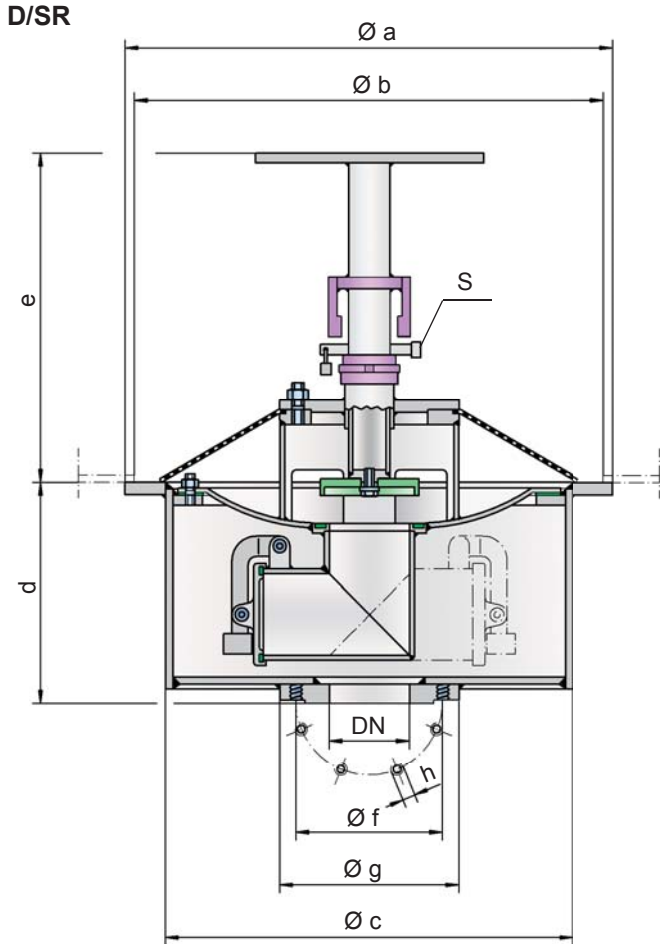

Function and Description

The PROTEGO® roof drain valves D/SR or D/SR-W function like collection bowls and pass the collected rain water from the floating roof through the scissor pipes of a PROTEGO® floating roof drainage system, such as SE/K or SE/CK, into the sewage water system.

Under normal operating conditions the roof drain valve is open. In case of any leakage the non-return valve prevents the stored medium from escaping to the floating roof. The inlet screen protects the roof drain valve from any dirt, leaves or nesting birds.

Design Types and Specifications

Two designs are available:

Roof drain valve with vertical connection **D/SR**

Roof drain valve with horizontal connection **D/SR-W**

As an option a special design of the roof drain valve is available with protection against unauthorized closing of the quick-action shut-off (S).

Table 1: Dimensions D/SR Dimensions in mm / inches

DN	80 / 2"	100 / 4"	150 / 6"
a	550 / 21.65	600 / 23.62	650 / 25.59
b	490 / 19.29	540 / 21.26	590 / 23.23
c	450 / 17.72	500 / 19.69	550 / 21.65
d	240 / 9.45	280 / 11.02	330 / 12.99
e	490 / 19.29	490 / 19.29	490 / 19.29
f	160 / 6.3	180 / 7.09	240 / 9.45
g	200 / 7.87	220 / 8.66	285 / 11.22
h	M 16	M 16	M 20

Table 2: Dimensions D/SR-W Dimensions in mm / inches

DN	80 / 2"	100 / 4"	150 / 6"
a	550 / 21.65	600 / 23.62	650 / 25.59
b	490 / 19.29	540 / 21.26	590 / 23.23
c	450 / 17.72	500 / 19.69	550 / 21.65
d	205 / 8.07	250 / 9.84	320 / 12.6
e	490 / 19.29	490 / 19.29	490 / 19.29
f	285 / 11.22	320 / 12.6	350 / 13.78
g	150 / 5.91	180 / 7.09	225 / 8.86

Table 3: Material selection

Design	A	B
Housing	Steel	Stainless Steel
Non-return valve	Red Brass	Red Brass
Valve disc	Steel	Stainless Steel
Quick-action shut-off	Steel	Stainless Steel
Gasket	PUR	PUR

The device must have sufficient corrosion resistance with regards to the stored media. If necessary, designs in special stainless steel quality should be selected.

Flange Connection Type

In type PROTEGO® D/SR the housing bottom is equipped with a loose flange with threaded holes according to EN 1092-1 or optionally according to any other international standard.

In the standard model of PROTEGO® D/SR-W the housing is equipped with a lateral flange connection to EN 1092-1. Optionally, the connecting flanges can be made according to any other international standard. An additional flange connection is available.

Selection and Design

The specified maximum rainfall is required to determine the required nominal size. Alternatively, the connection size of the roof drain valve corresponds with the existing nominal dimension of the floating roof drainage system. Roof drain valves with 2 or 3 non-return valves are available as an option.

Necessary Data for Specification

Maximum rainfall to be drained off (m³/h or CFH)

Material of floating roof

Connection size of the floating roof drainage system DN (mm or inches)

Design of floating roof drainage system

Application Examples

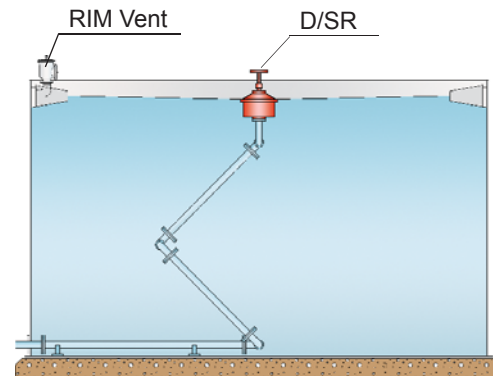

PROTEGO® roof drain valve type D/SR in combination with Floating roof drainage system PROTEGO® SE/CK

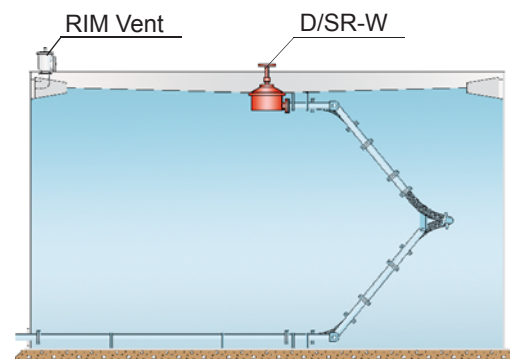

PROTEGO® roof drain valve type D/SR-W in combination with Floating roof drainage system PROTEGO® SE/K.

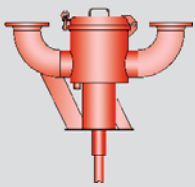

Vent Valve, Lift-actuated



PROTEGO® AL/DK and PROTEGO® AL 200

AL/DK

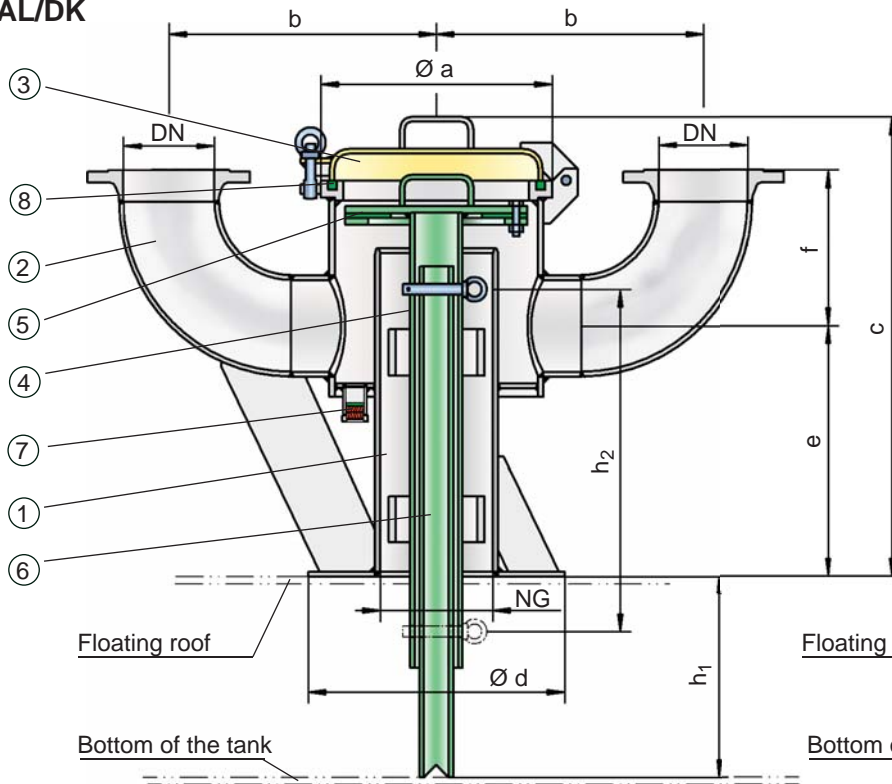

AL 200

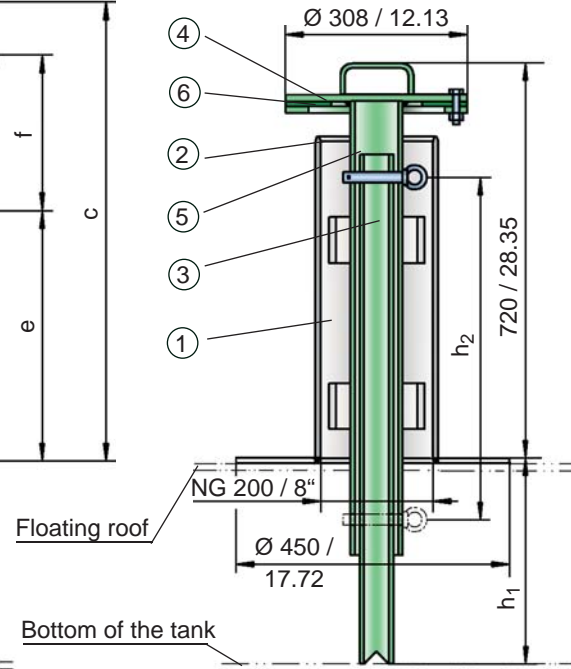

Dimensions in mm / inches

Function and Description

PROTEGO® lift-actuated vent valves type AL/DK provide automatic venting of floating roof tanks when the floating roof is lowered on its supports and the tank is either finally drained or refilled. When the floating roof is in its lowest position the valve is forced to open through lift actuation and this prevents unacceptable vacuum during final draining or unacceptable pressure during refilling.

In general the device consists of a housing (1) with sheet-metal panel to be welded on the floating roof, two or four connection nozzles (2) for installation of vent caps, cover (3), lift (4) including valve pallet (5), lift pipe (6) and the condensate drain valve (7) which can be flame transmission proof if required. A flat gasket is attached to the valve pallet (5) to provide sealing. The cover (3) is sealed by a sealing cord (8).

In general the device PROTEGO® AL 200 consists of a housing (1) with sheet-metal panel to be welded on the floating roof as well as the valve seat (2), lift (3) including valve pallet (4) and lift pipe (5). A flat gasket (6) which provides sealing.

As the lowest position of the floating roof varies for operation and assembly specify the dimensions h_1 and h_2 :

h_1 : Distance between lower edge of sheet-metal panel (or mounting flange) and tank bottom in lowest position of floating roof (operating position with an empty tank).

h_2 : Distance between floating roof in lifted maintenance position and height of floating roof in fully lowered operating position, if the tank is empty.

If the floating roof supports are changed from operating position to maintenance position the lift has to be lengthened as well. This is done with an adjustable locking pin that is secured with a bolt.

The valve is not flame transmission proof.

A hazard analysis (which considers the material selection and function of the device) shows that the device doesn't have any potential sources of ignition. Therefore they are not subject to the European Explosion Protection Directive (ATEX) when used in explosive atmosphere.

Designs and Specifications

Table 1: Dimensions for AL/DK

NG	200 / 8"	200 / 8"	200 / 8"	200 / 8"
DN	80 / 3"	100 / 4"	150 / 6"	200 / 8"
a	350 / 13.78	350 / 13.78	350 / 13.78	350 / 13.78
b	465 / 18.31	465 / 18.31	465 / 18.31	515 / 20.28
c	870 / 34.25	870 / 34.25	870 / 34.25	870 / 34.25
d	450 / 17.72	450 / 17.72	450 / 17.72	450 / 17.72
e	345 / 13.58	360 / 14.17	385 / 15.16	415 / 16.34
f	460 / 18.11	445 / 17.52	285 / 11.22	370 / 14.57

Dimensions in mm / inches

Table 2: Material

Housing	Steel	special materials upon request
Valve guide	Stainless Steel	
Gasket	FPM	

Table 3: Flange connection type DN

EN 1092-1, Form B1	other types upon request
ASME B16.5; 150 lbs RFSF	

Selection and Design

The required quantity and nominal size DN will be defined based on the calculated flow rate from the thermal venting and pump rate in lowest floating roof position (Nm³/h or CFH) and based on the maximum acceptable tank pressure p_T (mbar / inch W.C.) according to the flow capacity charts. Special models are available on request.

Flow rates and pressure losses of vent caps PROTEGO® EB or PROTEGO® LH/AD have additionally to be taken into account according to the appropriate charts in the relevant data sheets. Lift-actuated vent valves PROTEGO® AL 200 can be applied in case just venting is required.

Necessary Data for Specification

Stored product

Tank diameter (m or ft)

Tank height (m or ft)

Support height h₁ (operating position with empty tank)

Support height h₂ (lifted assembly position)

Maximum allowable tank pressure p_T (mbar or inch W.C.)

Pump rate (m³/h or CFH)

Application Examples for PROTEGO® AL/DK

Lift-actuated vent valves of type PROTEGO® AL/DK can be combined with vent caps type EB which are deflagration proof and resistant against endurance burning. This ensures flame transmission proof ventilation.

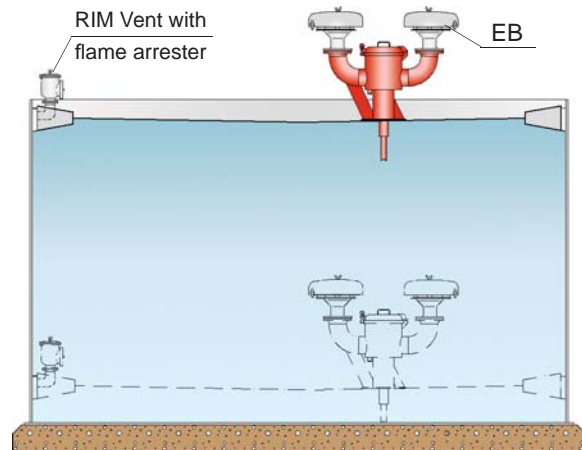

If resistance against endurance burning is not required the valves can alternatively be combined with PROTEGO® deflagration proof devices type PROTEGO® LH/AD. The applicable data sheets are available in volume 2 "Deflagration Flame Arresters, end-of-line and Vent Caps".

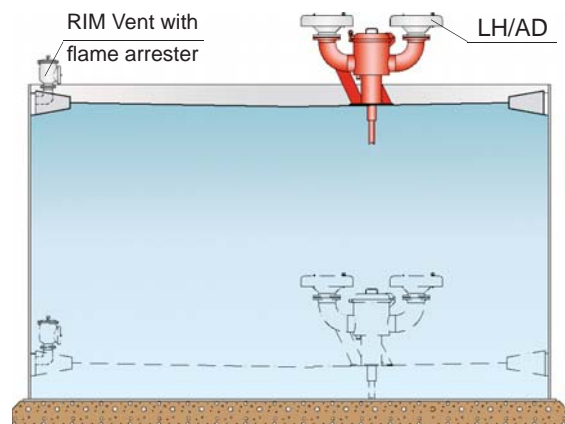

Application Examples for PROTEGO® AL 200

PROTEGO® AL 200 for fixed roof storage tanks with internal floating roof.

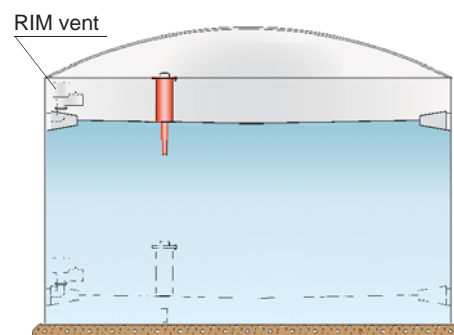

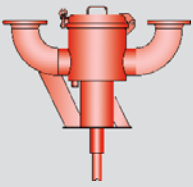

Vent Valve, Lift-actuated
Flow Capacity Charts

PROTEGO® AL/DK and PROTEGO® AL 200

DN 200 - 100 / 8" - 4"
 DN 200 - 150 / 8" - 6"
 DN 200 - 200 / 8" - 8"

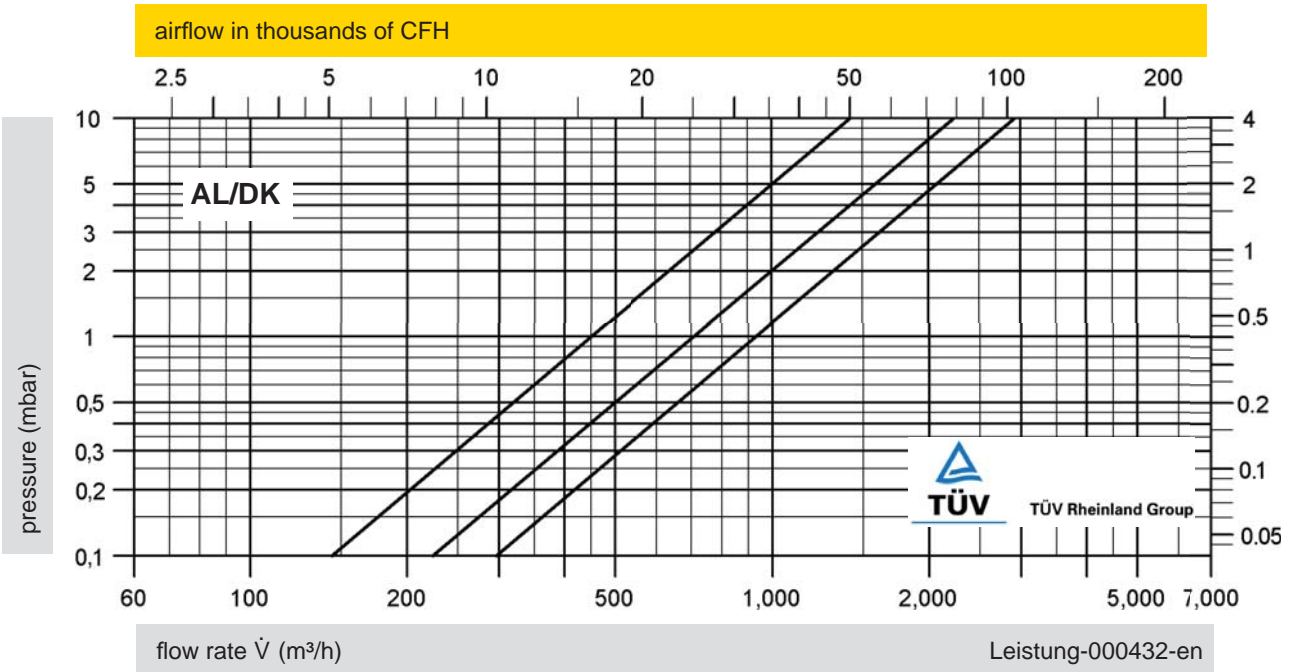

pressure - inch W.C.

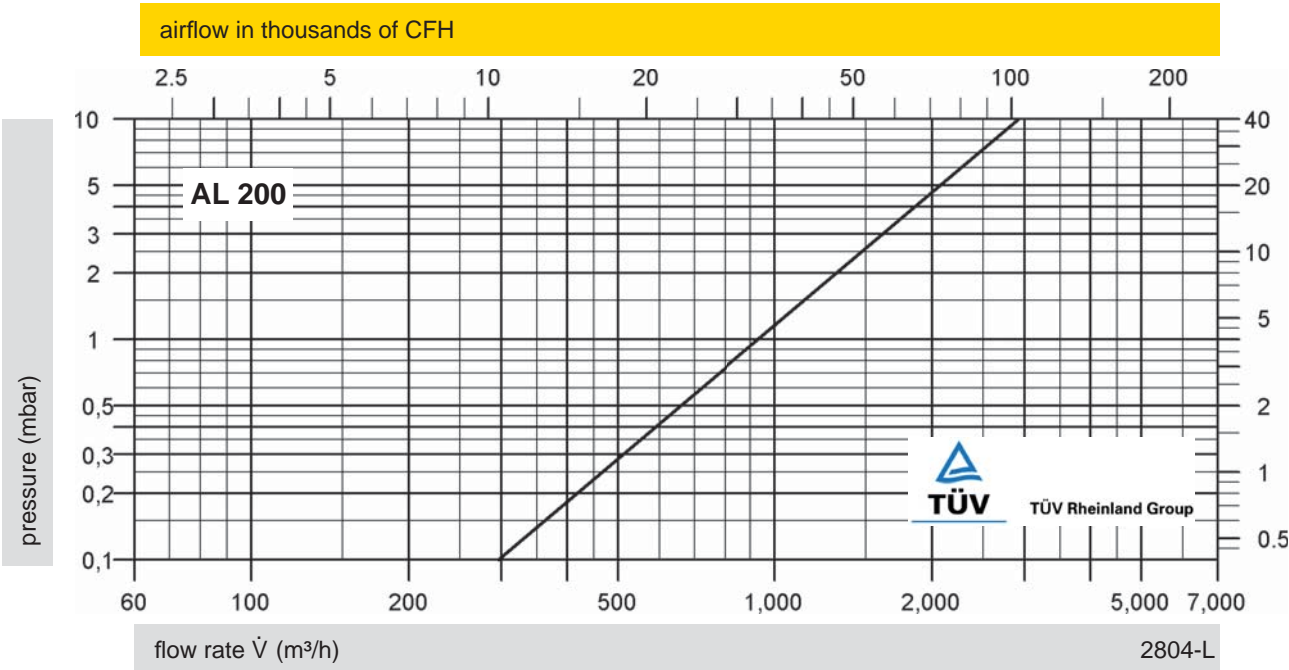

pressure - inch W.C.

The flow capacity charts have been determined with a calibrated and TÜV certified flow capacity test rig. Volume flow \dot{V} in (m³/h) and CFH refer to the standard reference conditions of air ISO 6358 (20°C, 1bar). Conversion to other densities and temperatures refer to Vol. 1: "Technical Fundamentals".



Gauge Hatch with flange



PROTEGO® PF/K, PF/TK and PS/KF

PROTEGO® PF/K

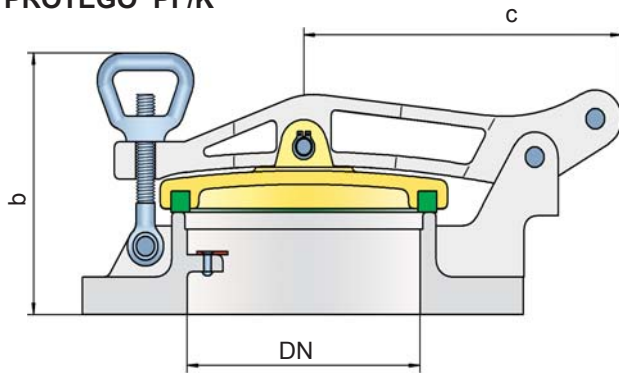

Design "I"
remaining open

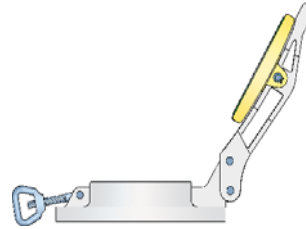

Design "II"
automatic cover closing

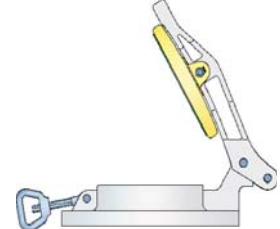

PROTEGO® PF/TK

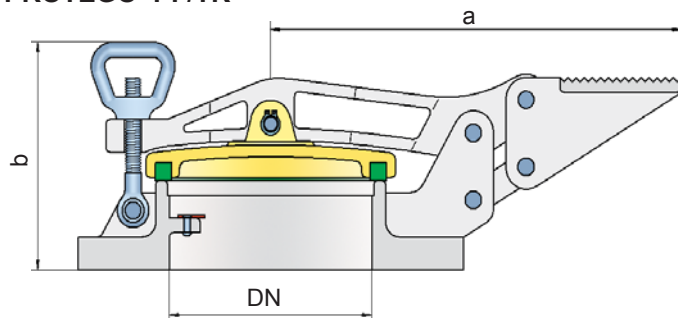

Pedal-operated version
automatic cover closing

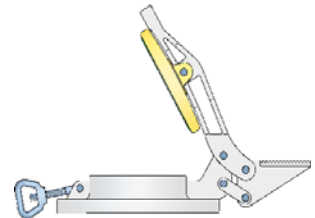

PROTEGO® PS/KF

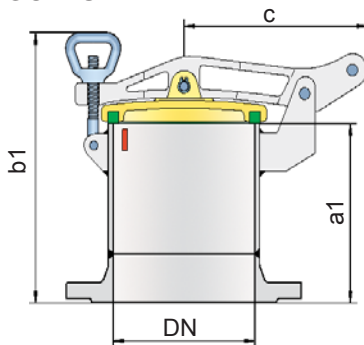

Design "I"
remaining open

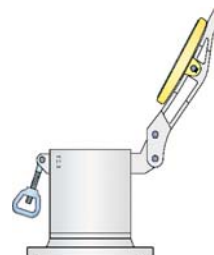

Design "II"
automatic cover closing

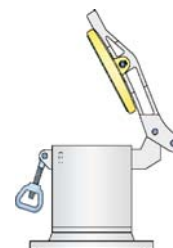

Function and Description

PROTEGO® gauge hatches types PF/K, PF/TK and PS/KF are used as lockable gauge nozzles which are only opened for gauging or sampling. Otherwise they are tightly closed.

The gauge hatches PROTEGO® PF/K, PF/TK and PS/KF mainly consist of housing, cover and bracket. As a standard the housing has stainless steel gauge marks.

In the pedal-operated version PROTEGO® PF/TK the gauging nozzle pedal is connected to both the housing and the bracket.

Design Types and Specifications

Depending on the intended use the following designs are available:

- Gauge hatch with flange **PF/K** design I and II
 „I“ : remaining open
 „II“ : automatic cover closing
- Gauge hatch with flange and pedal **PF/TK** automatic cover closing
- Gauge hatch with flange nozzle **PS/KF** design I and II
 „I“ : remaining open
 „II“ : automatic cover closing

Gauge hatches for welding to the tank are available as types PROTEGO® PS/K and PS/TK. A separate data sheet is available.

Table 1: Dimensions		Dimensions in mm / inches		
DN	100 / 4"	150 / 6"	200 / 8"	
a	260 / 10.24	305 / 12.01	335 / 13.19	
b	150 / 5.91	155 / 6.10	175 / 6.89	
c	160 / 6.30	205 / 8.07	235 / 9.25	
a1	225 / 8.86	265 / 10.43	300 / 11.81	
b1	315 / 12.40	360 / 14.17	405 / 15.94	

The nominal size depends on the dimensions of the gauging and sampling device.

Table 2: Material selection				
Design	A	B	C	D
Housing	Ductile Iron*	Stainless Steel	Aluminium	Steel
Cover	Ductile Iron*	Stainless Steel	Aluminium Stainless Steel**	Steel

The combination of steel and aluminium in explosive environments is prohibited due to ignition danger.

* only for PF/K and PF/TK

** only for PF/TK-100

Flange Connection Type

The flange connection is to EN 1092-1, Form A. Optionally, the connecting flange can be made according to any international standard.

Necessary Data for Specification

- Stored product
- Tank material
- Tank nozzle DN (mm or inches)

Application Examples

Gauge Hatches can for instance be used in combination with the manual gauge devices type PROTEGO® H/P or with the gauging and sampling device PROTEGO® VP/HK.

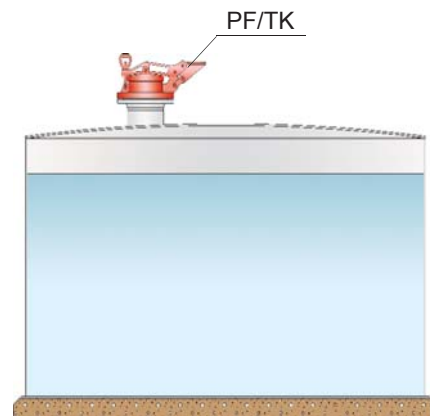

Gauge Hatches can be applied on tanks with floating roof.

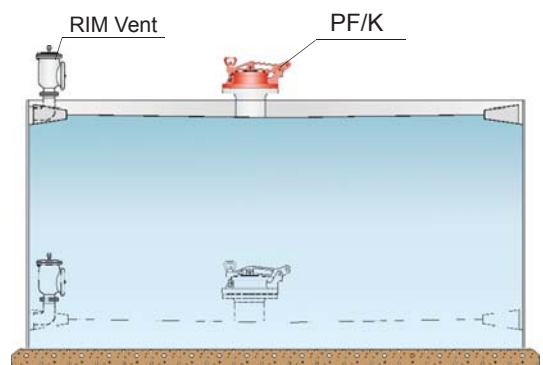

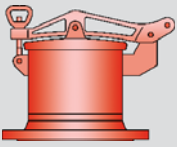

Gauge Hatch with welded nozzle

PROTEGO® PS/K, PS/TK



PROTEGO® PS/K

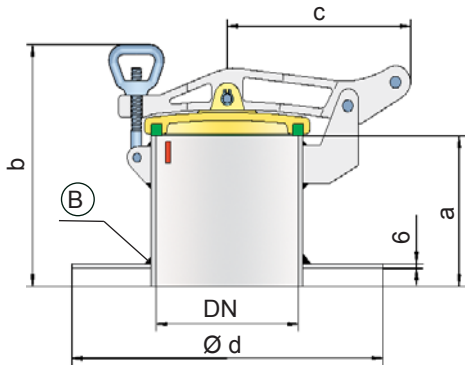

Design "I"
remaining open

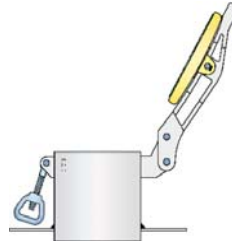

Design "II"
automatic cover closing

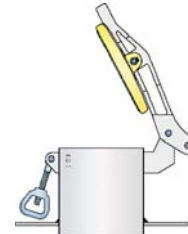

PROTEGO® PS/TK

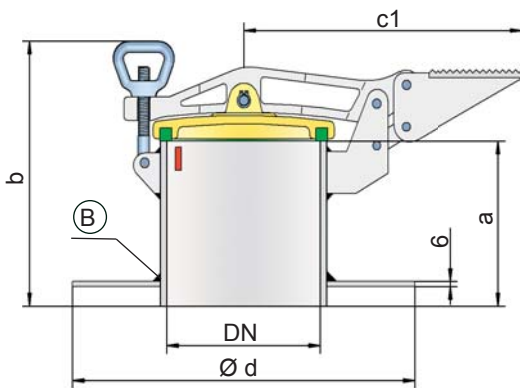

Pedal-operated version
automatic cover closing

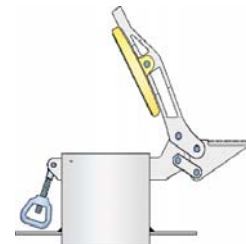

Ⓑ Welding on-site

Function and Description

PROTEGO® gauge hatches types PS/K and PS/TK are used as lockable gauge nozzles which are only opened for gauging or sampling.

The gauge hatches PROTEGO® PS/K and PS/TK mainly consist of housing, cover and bracket. As a standard the housing has stainless steel gauge marks.

In the pedal-operated version PROTEGO® PS/TK the gauging nozzle pedal is connected to both the housing and the bracket.

Design Types and Specifications

Depending on the intended use the following designs are available:

Gauge hatch with welding nozzle

PS/K design I and II
„I“ : remaining open
„II“ : automatic cover closing

Gauge hatch with welding nozzle and pedal

PS/TK automatic cover closing

Gauge hatches with flange are available as type PROTEGO® PF/K, PF/TK and PS/KF. A separate data sheet is available.

Table 1: Dimensions		Dimensions in mm / inches	
DN	100 / 4"	150 / 6"	200 / 8"
a	175 / 6.89	225 / 8.86	250 / 9.84
b	265 / 10.43	320 / 12.60	355 / 13.98
c	160 / 6.30	205 / 8.07	235 / 9.25
c1	260 / 10.24	305 / 12.01	335 / 13.19
d	275 / 10.83	350 / 13.78	450 / 17.72

The nominal size depends on the dimensions of the gauging and sampling device.

Table 2: Material selection		
Design	A	B
Housing	Steel	Stainless Steel*
Cover	Ductile Iron	Stainless Steel*

* only for PS/K

Flange Connection Type

The flange connection is to EN 1092-1, Form A. Optionally, the connecting flange can be made according to any international standard.

Necessary Data for Specification

Stored product

Tank material

Tank nozzle DN (mm or inches)

Application Examples

Gauge Hatches can for instance be used in combination with the manual gauge devices type PROTEGO® H/P or with the gauging and sampling device PROTEGO® VP/HK.

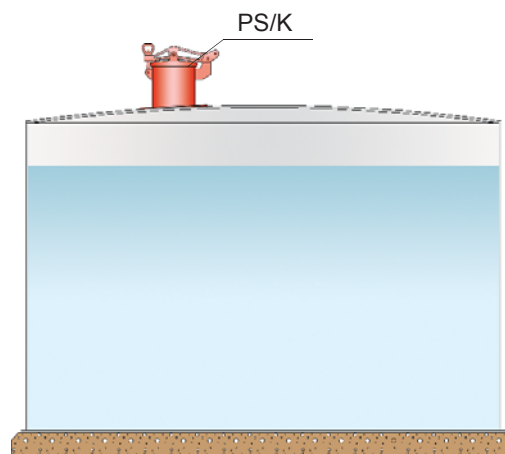

Gauge Hatches can be welded on tanks with floating roof.

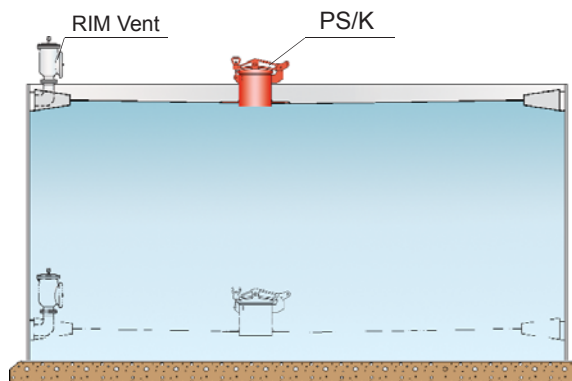



Sampling and Air Bleed Valve

deflagration proof

PROTEGO® ZE/WU

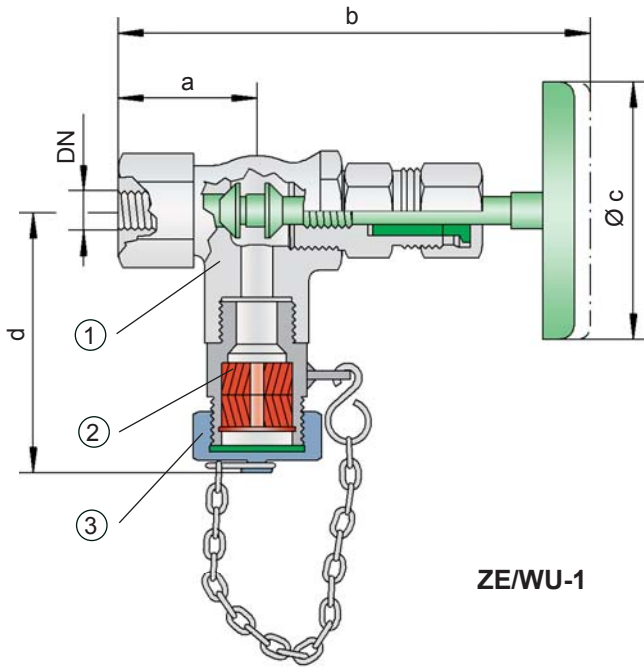

ZE/WU-1

Standard design up to PN 25

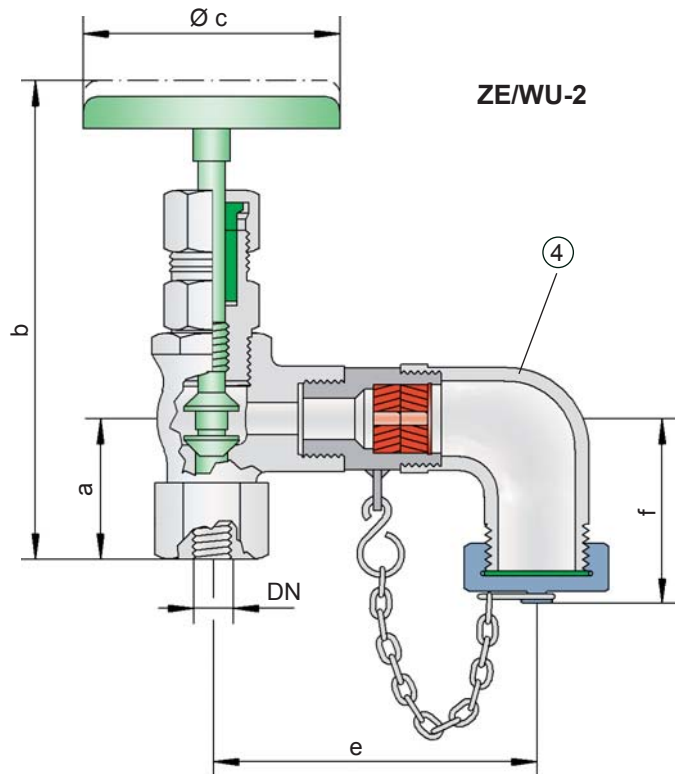

ZE/WU-2

Function and Description

The PROTEGO® ZE/WU sampling and air bleed valve is used for flame transmission proof venting of pipelines and equipment that transports or processes flammable liquids, and for taking liquid samples. The valve incorporates an end-of-line deflagration flame arrester. Should the gas/air mixtures or product vapour/air mixtures ignite during venting, the valve prevents flash back into the system to be protected.

The sampling and air bleed valve PROTEGO® ZE/WU consists of the threaded angle valve in pressure stage PN25 (1) with hand wheel as standard design and female threaded connection (pipe thread G½" up to G1") and the flame arrester (2) with cover (3).

As an optional elbow fitting (4) is available as outlet for sampling. The flame arrester (2) consists of the flame arrester cage with FLAMEFILTER®.

The valve opens manually with the hand wheel. For sampling, a suitable container is required.

The simple and sturdy design makes it suitable for nearly all flammable liquids. This device can be installed in any position.

Flame transmission protection is guaranteed against atmospheric deflagrations of gas/air mixtures or product vapour/air mixtures of explosion groups up to IIB (NEC group D to C) up to a service temperature of +60°C / 140°F and an absolute operating pressure up to 1.1 bar / 15.9 psi.

Type-approved in accordance with the current ATEX Directive and EN ISO 16852 as well as other international standards.

Designs and Specifications

There are two designs available:

Sampling and air bleed valve, standard design **ZE/WU - 1**

Sampling and air bleed valve with elbow **ZE/WU - 2**

Special designs for higher pressures are available

Optionally available with flange connection (see figure)

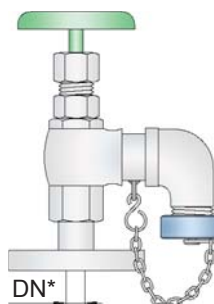

* Position of drilling holes on flange connection as well as thickness upon request for size DN15 / ½", DN20 / ¾", DN25 / 1", DN32 / 1¼", DN40 / 1½" and pressure nominal PN25/40 resp. PN100 available.

Table 1: Dimensions		Dimensions in mm / inches				
DN	a	b	Ø c	d	e	f
15 / G½"	40 / 1.57	140 / 5.51	70 / 2.76	80 / 3.15	96 / 3.78	67 / 2.64
20 / G¾"	50 / 1.97	165 / 6.50	85 / 3.35	80 / 3.15	89 / 3.50	67 / 2.64
25 / G1"	65 / 2.56	200 / 7.87	100 / 3.94	95 / 3.74	104 / 4.09	67 / 2.64

Table 2: Explosion group		
MESG	Expl. Gr. (IEC/CEN)	Gas Group (NEC)
≥ 0,50 mm	IIB	B

Table 3: Material	
Design	A
Threaded angle valve	Stainless Steel
Elbow	Stainless Steel
Cover	Stainless Steel
FLAMEFILTER®	Stainless Steel

The valve must be sufficiently resistant to corrosion through the gas/air mixtures or product vapor/air mixtures. This applies mainly to the FLAMEFILTER®.

Table 4: Type of connection	
Pipe thread DIN ISO 228 T1	DIN



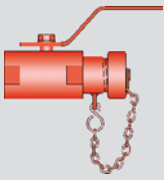

Condensate Drain Valve deflagration proof

PROTEGO® ZE/TK



ZE/TK-1

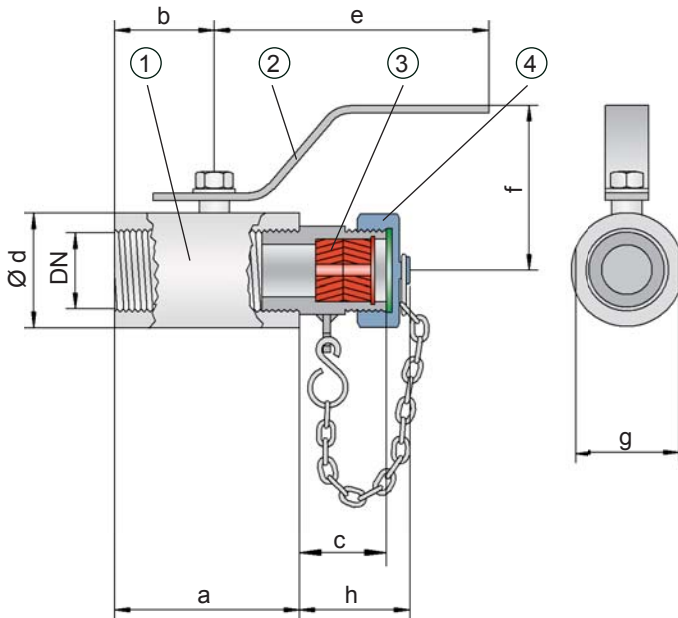

ZE/TK-2

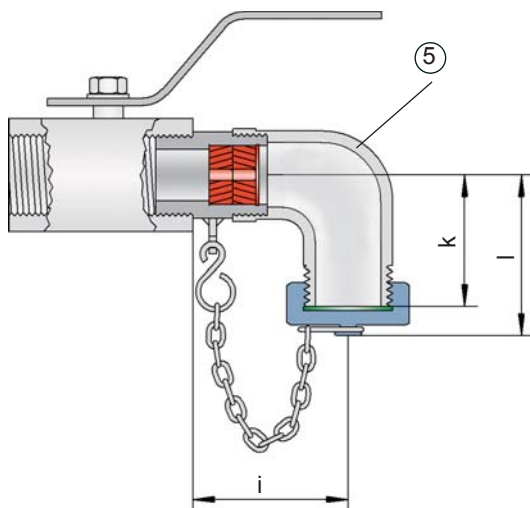

Function and Description

The PROTEGO® ZE/TK condensate drain valve is used for flame transmission proof condensate drainage of devices or plant equipment (e.g. tanks, pipelines, etc.) where flammable liquids may condense and therefore flammable product vapour/air mixtures could develop. Furthermore the drain valves can be used for the venting of tanks, parts of plants and lines that transport or process flammable liquids. The drain valve incorporates an end-of-line deflagration flame arrester.

The condensate drain valve PROTEGO® ZE/TK consists of the ball valve (1) with hand lever (2) and female threaded connection (e.g. pipe thread G½" up to G1") and the flame arrester (3) with cover (4).

As an option a elbow fitting (5) is available as outlet.

The flame arrester (3) consists of flame arrester cage and FLAMEFILTER®.

The ball valve is opened with the hand lever. When draining condensate use a suitable container. When draining flammable and/or toxic products observe the appropriate safety provisions.

The simple and sturdy design it is suitable for nearly all flammable liquids, and can be installed in any position.

Flame transmission protection is guaranteed against atmospheric deflagrations of product vapour/air mixtures of explosion groups up to IIB (NEC groups D to C) up to a service temperature of +60°C / 140°F and an absolute operating pressure up to 1.1 bar / 15.9 psi.

Type-approved in accordance with the current ATEX Directive and EN ISO 16852 as well as other international standards.

Designs and Specifications

There are two designs available:

Condensate drain valve, standard design **ZE/TK - 1**

Condensate drain valve with elbow **ZE/TK - 2**

Special designs are available on request.

Table 1: Dimensions

Dimensions in mm / inches

DN	a	b	c	Ød	e	f	g	h	i	k	l
15 / G½"	60 / 2.36	30 / 1.18	33 / 1.30	32 / 1.26	110 / 4.33	55 / 2.17	27 / 1.06	45 / 1.77	54 / 2.13	38 / 1.50	67 / 2.64
20 / G¾"	65 / 2.56	35 / 1.38	33 / 1.30	38 / 1.50	110 / 4.33	60 / 2.36	34 / 1.34	45 / 1.77	54 / 2.13	38 / 1.50	67 / 2.64
25 / G1"	73 / 2.87	40 / 1.57	33 / 1.30	45 / 1.77	110 / 4.33	65 / 2.56	41 / 1.61	45 / 1.77	54 / 2.13	38 / 1.50	67 / 2.64

Table 2: Explosion group

MESG	Expl. Gr. (IEC/CEN)	Gas Group (NEC)
≥ 0,50 mm	IIB	B

Table 3: Material

Ball valve	Stainless Steel
Elbow	Stainless Steel
Cover	Stainless Steel
FLAMEFILTER®	Stainless Steel

The valves must be sufficiently resistant to corrosion through the gas/air mixtures or product vapour/air mixtures. This applies mainly to the FLAMEFILTER®. If necessary, designs in special stainless steel quality should be selected.

Table 4: Type of connection

Pipe thread DIN ISO 228 T1	DIN
----------------------------	-----



for safety and environment

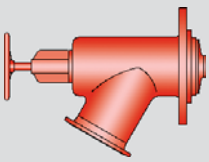

In-tank Valve
Internal Safety Valve

PROTEGO® SI/F

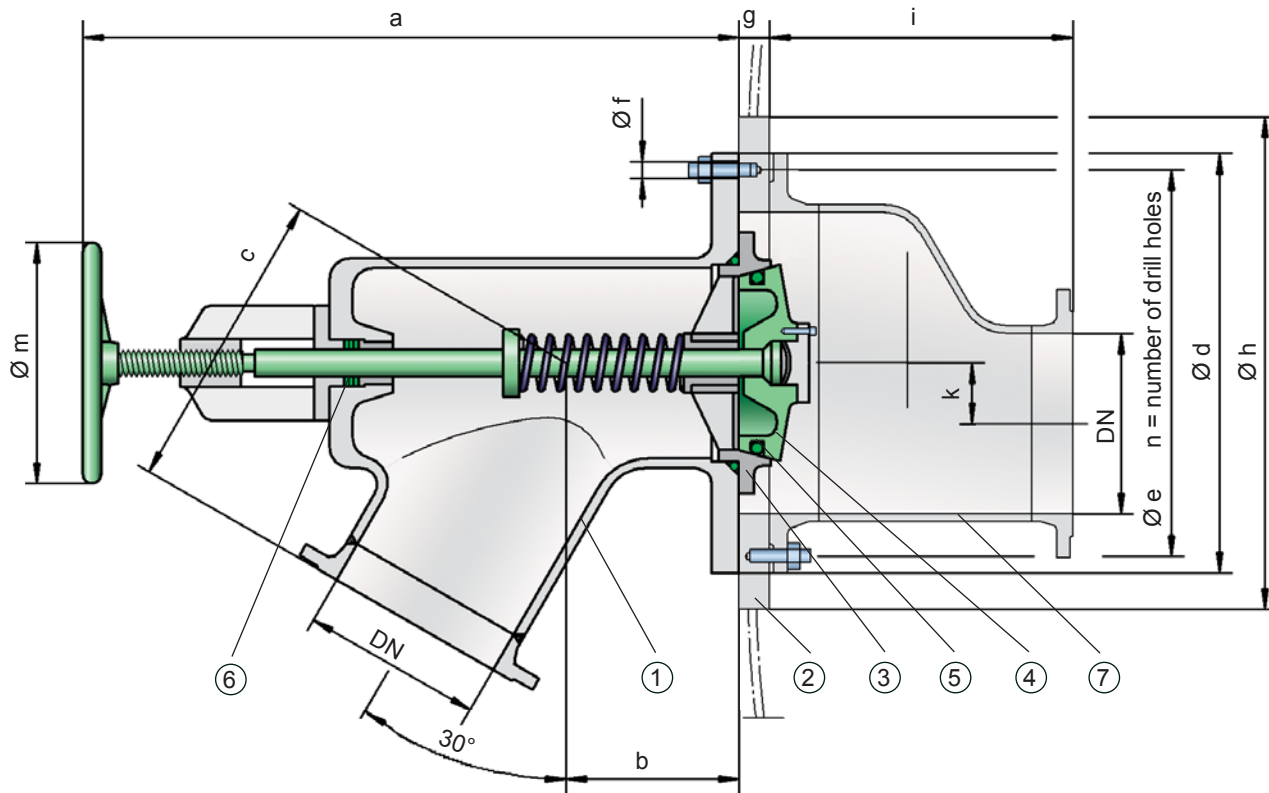

Function and Description

The PROTEGO® in-tank valve type SI/F is a shut-off valve and protects the downstream liquid lines of storage tanks and tanks in process plants of the chemical, petrochemical and pharmaceutical industries, thus increasing both safety and availability of the plants.

The in-tank valve SI/F (figure 1) consists of housing (1), mounting flange (2), valve seat (3), valve disc (4) and sealing (5). The mounting flange is welded into the tank shell. The valve seat is replaceable. The valve seat and valve disc are lapped metallic surfaces and an additional O-ring is installed to ensure the required tightness. The spindle sealing (6) can be adjusted or replaced and is designed for a test pressure of 25 bar / 363 psi.

A gate valve that is supplied by the user and serves for normal operation is connected to the external nozzle of the housing. The internal safety valve is kept open under normal operating conditions. It is only closed for longer shut-downs, in case of emergency or for necessary repairs to the gate valve.

It is closed by an “internal sealing”, e.g. the valve is closed inside of the tank. This ensures that the tank cannot leak in case of damage to external components or leakages in any connected pipelines.

The special design of PROTEGO® in-tank valves of type SI/F is such that only the mounting flange (2) is welded to the tank shell, and so most other parts can be replaced. Replacement of important external parts does not require the draining of the tank. This fact provides significant operation advantages.

Type SI/F by PROTEGO® is available in a range of nominal sizes and materials. Optionally, the in-tank valve can be equipped with an internal nozzle (7) to connect to a suction and filling pipe or a swing pipe system (SI/FA).

Tank shut-off valves of this type are usually operated manually. Versions with an explosion proof electric actuator for direct or remote control are also available.

Alternatively it is possible to use special versions with pneumatic control (PROTEGO® SI/DP) under specific tank design (e.g. full containment tank system).

Design Types and Specifications

Two designs are available:

- In-tank valve, standard design **SI/F**
- In-tank valve with internal connection nozzle (7) **SI/FA**

Table 1: Dimensions

Dimensions in mm / inches

DN	a	b	c	d	e	f	g	h	i	k	m	n
50 / 2"	371/14.61	75/2.95	170/6.69	240/9.45	205/8.07	14/0.55	30/1.18	305/12.01	250/9.84	54/2.13	200/7.87	8
65 / 2 1/2"	400/15.75	85/3.35	190/7.48	305/12.01	205/8.07	14/0.55	30/1.18	305/12.01	240/9.45	45/1.77	200/7.87	8
80 / 3"	416/16.38	90/3.54	200/7.87	330/12.99	230/9.06	14/0.55	30/1.18	330/12.99	290/11.42	53/2.09	200/7.87	8
100 / 4"	434/17.09	100/3.94	225/8.86	270/10.63	230/9.06	14/0.55	30/1.18	330/12.99	270/10.63	40/1.57	200/7.87	8
150 / 6"	658/25.91	130/5.12	320/2.60	410/16.14	370/14.57	18/0.71	40/1.57	505/19.88	440/17.32	78/3.07	400/15.75	12
200 / 8"	725/28.54	145/5.71	365/14.37	540/21.26	405/15.94	18/0.71	45/1.77	540/21.26	450/17.72	68/2.68	400/15.75	12

Table 2: Material selection

Design	A	B
Housing	Steel	Stainless Steel
Valve seat	Stainless Steel	Stainless Steel
Valve disc	Stainless Steel	Stainless Steel
Spring	Stainless Steel	Stainless Steel
Bushing	PTFE	PTFE
Hand wheel	Aluminium	Aluminium
Spindle sealing	PTFE	PTFE
Mounting flange	Steel	Stainless Steel

Table 3: Flange connection type DN

EN 1092-1, Form B1	other types upon request
ASME B16.5; 150 lbs RFSF	

Selection and Design

Together with the customer our engineers design and specify the valve for each specific application. The relevant plant specifications are taken into account when defining the required nominal sizes and connection types. Also the operating temperature and resulting special operating conditions may require special materials. The mounting flange material must be compatible with the tank material. If there are special requirements for the valve or operating parameters please contact us: If necessary we will arrange for special designs.

Necessary Data for Specification

Stored medium

Tank height (m or ft)

Tank material

Connection diameter of drain pipe, DN (mm or inch)

Application Examples

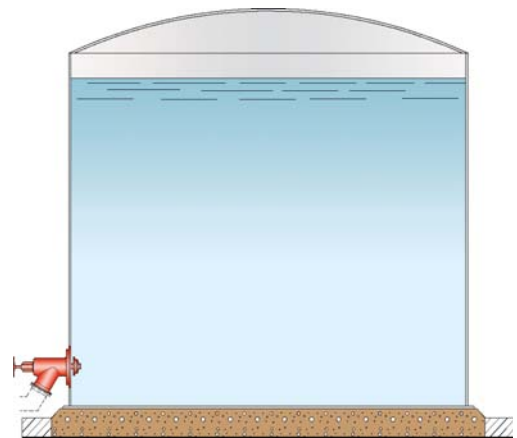

PROTEGO® SI/F

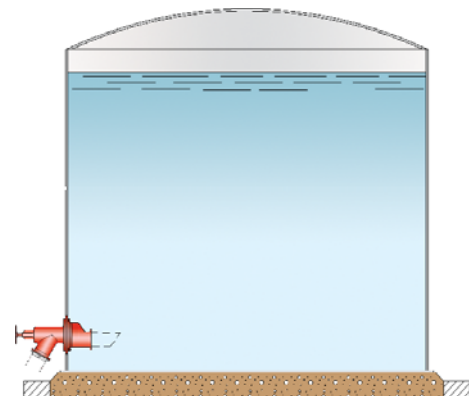

PROTEGO® SI/FA with internal connection nozzle

www.protego.com



for safety and environment

PROTEGO® Equipment for Cryogenic Storage Tanks



Volume 9



for safety and environment

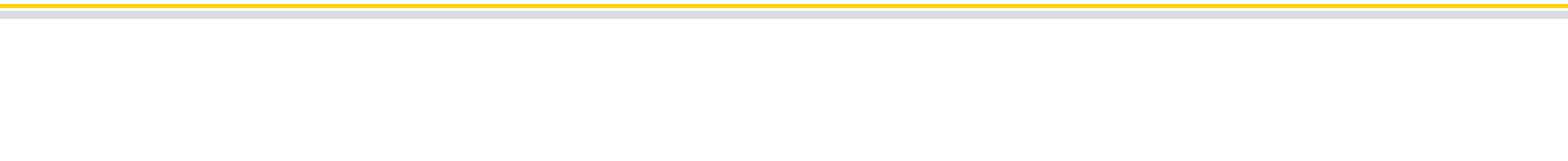
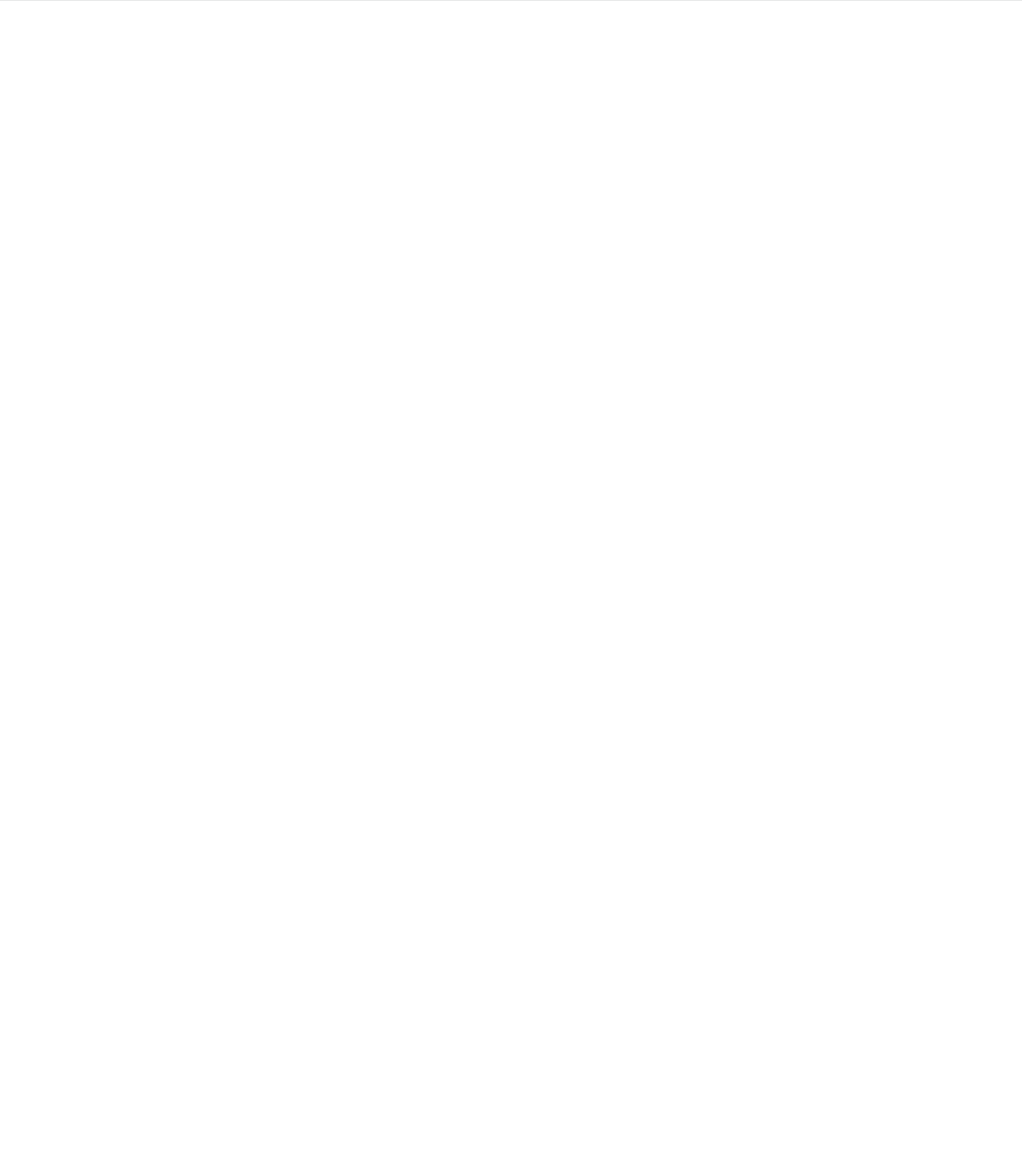
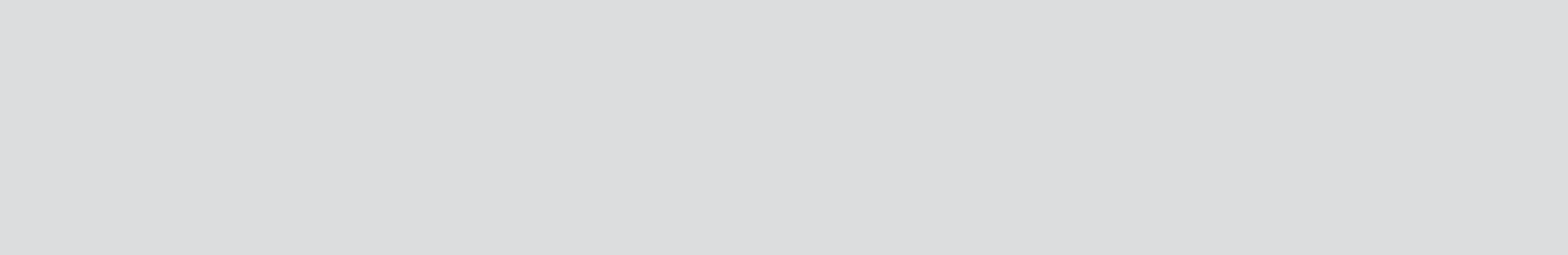



Pressure/vacuum relief valves

Decades of experience in producing pilot-operated pressure/vacuum relief valves plus state-of-the art knowledge and expertise in computer-optimized design and our extensive test facilities form the basis of development of most powerful vent valves.

The storage of cryogenic-liquified gases makes special demands on the venting devices required for tank equipment. These valves are designed in accordance with the applicable standards and with regard to the operating points of the various products in the process. Using pilot-operated pressure and vacuum relief valves - if necessary in combination with separate pallet valves - it is ensured that maximum permissible operating pressures of the tank are not exceeded in practice.

Thanks to their characteristic functioning principle, pilot-operated pressure and vacuum relief valves achieve highest tightness up to the set pressure. Spring-loaded and magnet-loaded pilots are the main valve's reliable switching components.

Optionally available are backflow preventers, test connections and test equipment for functional inspections at the place of installation.

By using shuttle valves, it is possible to operate valves in AND/OR mode of operation and to carry out maintenance at the place of use.











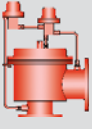



In-Tank Valves

So-called In-Tank Valves (internal safety valves) are used mainly in cryogenic tanks where the tank wall or the bottom is penetrated by the discharge pipe. In an emergency case of a failure of such lines the In-Tank Valve is working as a shut-off-valve to minimize spill of product and spread of danger.



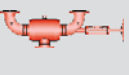

PROTEGO® Equipment for Cryogenic Storage Tanks

Type	Size	positive setting range mbar / inch W.C.	negative setting range mbar / inch W.C.	Design O = horizontal connection X = vertical connection	O = soft sealing X = metallic sealing	O = for non-standard operating parameters	O = for critical Medium (Polymerisation, Corrosion, Crystallisation)	O = Heating jacket, Heating coil	Page
Pressure and Vacuum Relief Valves, pilot-operated									
	PM/(D)S	80 - 300 3" - 12"	+10 up to +300 / +4.0 up to +120	-3.0 up to -7 / -1.2 up to -2.8	X	X	O		408 - 411
	PM-HF	80 - 300 3" - 12"	+10 up to +1034 / +4.0 up to +413.6	-2.2 up to -7 / -0.88 up to -2.8	X	X	O		412 - 415
	VN-A-PC	300 12"	+20 up to +1034 +8.0 up to 413.6	-3.0 up to -7 / -1.2 up to -2.8	X	X	O		NEW 
Vacuum Relief Valves, weight pallet type									
	V/SV-XL	300 12"		-2.0 up to -16 / -0.8 up to -6.4	X	O / X		O	NEW 416 - 417
	V/SV-XXL	300 12"		-2.0 up to -16 / -0.8 up to -6.4	X	O / X		O	NEW 418 - 419
	V/SV	40 - 300 1½" - 12"		-2.0 up to -60 / -0.8 up to -24	X	O / X		O	NEW 
Change-Over Valve									
	WV/T	80 - 250 3" - 10"							420 - 421
In-Tank Valves									
	NB/AP	150 - 200 6" - 8"	Description	In-Tank Valve Fast Action Bottom Drain Valve with pneumatic actuator					422 - 423
	ITV-S			In-Tank Valve with side					NEW 424 - 425
	SI/DP	150 - 300 6" - 12"		In-Tank Valve Internal Safety Valve					426 - 427



Cryogenic Tank Applications
(Flyer pdf)

Application Examples for Cryogenic Tanks

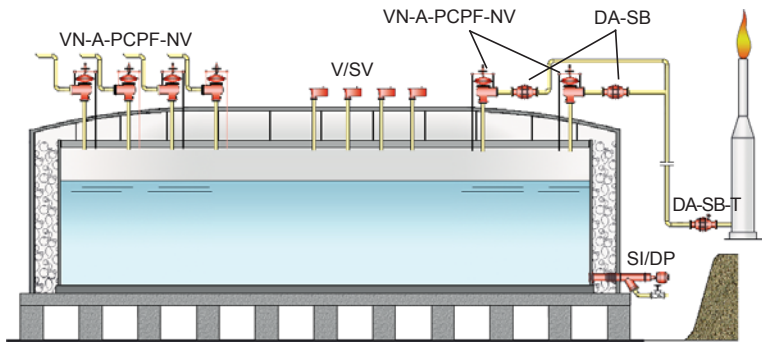

Ammonia Storage Tank

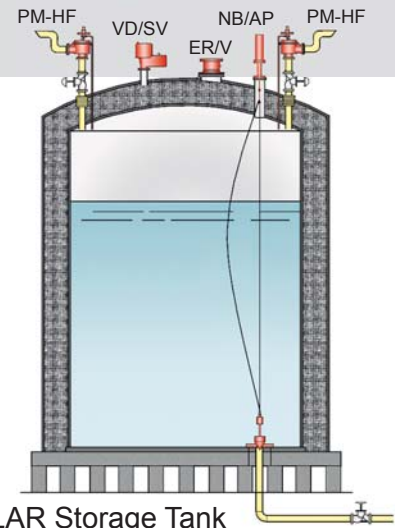

LIN-LOX-LAR Storage Tank

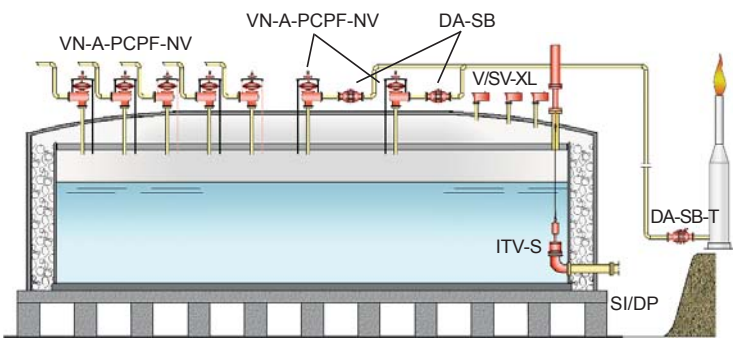

Ethylene Storage Tank

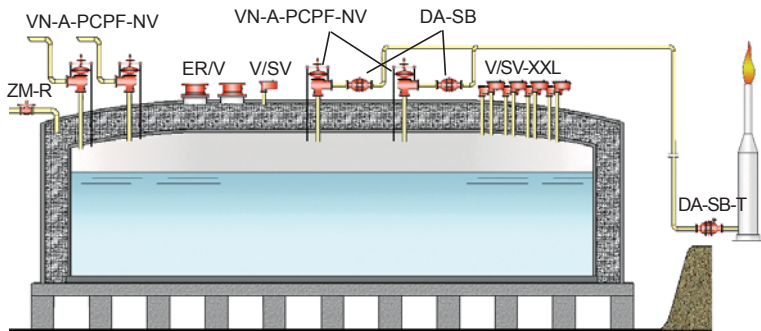

Propylene Storage Tank

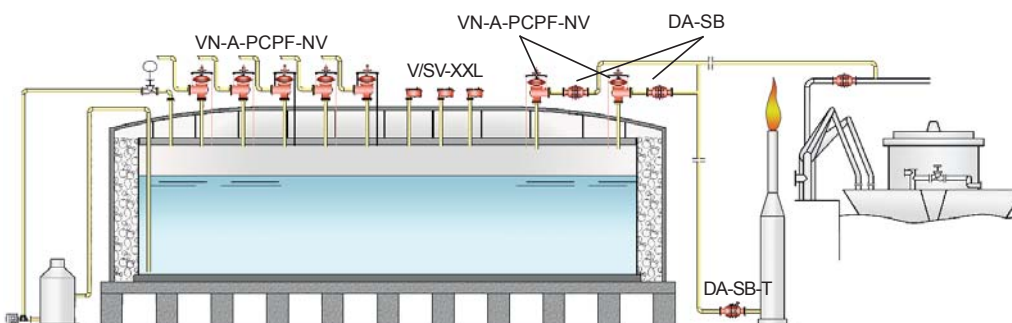

LNG Storage Tank

- Pilot Operated Valves that solve instability problems during operation such as fluttering and chattering.
- Cleaning for oxygen service available on request.
- Cryogenic Functional Test available on request.
- Low Pressure and Vacuum Conservation Vents.
 - Full lift technology available (fully open with only 10% overpressure/pressure accumulation)
 - Deadweight or spring loaded
- Extremely low leakage rates on Breather Valves (much lower than ISO 28300 and API 2000 7th ed.)
- Low Pressure Reducing Valves

- Pneumatic driven fast In-Tank Valves.
- Pneumatic and Manual driven Internal Safety Valves.

- ATEX approved Flame Arresters
 - End-of-line applications
 - Deflagration Flame Arresters
 - Endurance burning proof Flame Arresters
 - In-line applications
 - Deflagration Flame Arresters
 - Detonation Flame Arresters

- Sold globally. Serviced locally (PARC).
- Fully ATEX, ISO 9001 and ISO 14001 certified international company.

Products

- VN-A-PCPF-NV, V/SV, ITV-S (→)
- NB/AP, SI/DP, PM-HF (→ Volume 9)
- V/SV-XL, V/SV-XXL (→ Volume 9)
- DA-SB, DA-SB-T (→ Volume 4)
- VD/SV, ER/V (→ Volume 5)
- ZM-R (→ Volume 6)



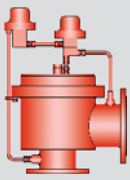

Pressure/Vacuum Relief Valve

Pilot-operated diaphragm valve

PROTEGO® PM/(D)S

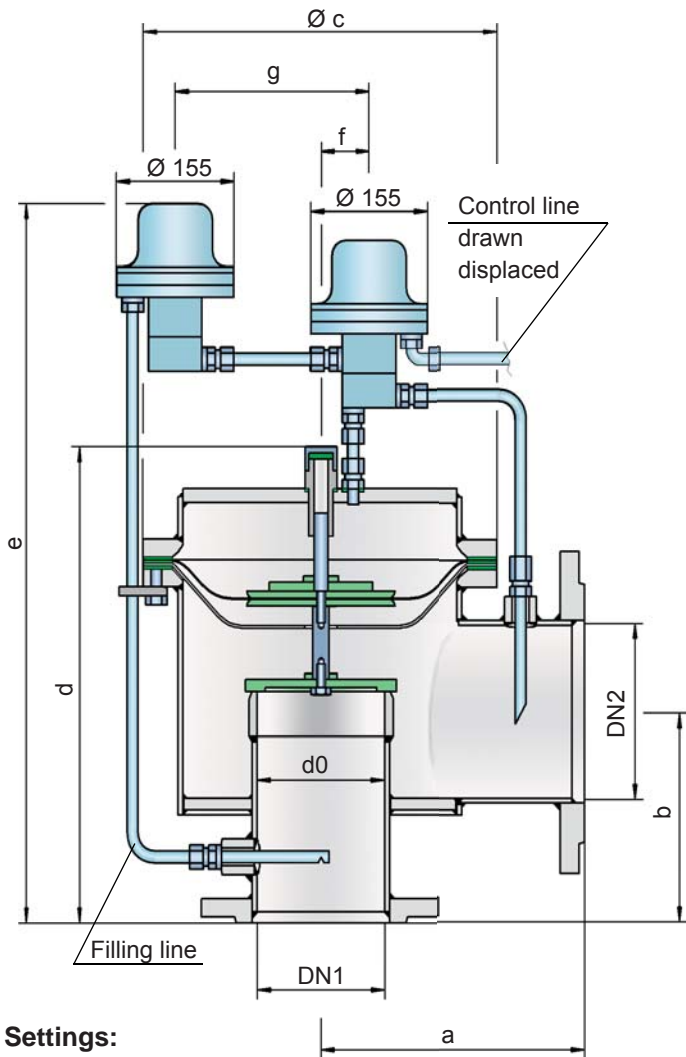

As the operating pressure increases, the closing force acting on the main valve also rises; e.g. the valve tightness increases to prevent leakage until the set pressure is reached. After the valve responds, it immediately opens completely without any significant increase in pressure (pop open characteristic), and the nominal volumetric flow is discharged through a fully open valve. If this level is exceeded, the pressure increase follows the flow performance curve ($\Delta p/\dot{V}$ curve). Up to the set pressure, the tank pressure is maintained with a tightness that is far superior to the conventional standard due to the superior manufacturing technology. This feature is achieved by valve seats made of high-grade stainless steel with precisely ground valve pallets. After the excess pressure is discharged or the vacuum is compensated, the valve reseats and provides a tight seal.

Special Features and Advantages

- high degree of safety due to double pilot
- controlled by corrosion-resistant, low-temperature-resistant permanent magnet
- the tank medium does not continuously flow through the pilot valve
- pop-open characteristic from a minimum pressure rise to full lift
- extreme tightness and hence least possible product losses and reduced environmental pollution
- set pressure is close to full lift pressure, which results in high level of design freedom and product savings
- high flow capacity
- the control diaphragm of the main valve is shielded from low temperatures - high-level durability
- can be used in areas subject to an explosion hazard
- designed for use at low temperatures
- self draining

Settings:

Pressure: +10 mbar up to +300 mbar
+4 inch W.C. up to +120 inch W.C.

Vacuum: -3.0 mbar up to -7 mbar
-1.2 inch W.C. up to -2.8 inch W.C.

Higher or lower settings upon request.

Function and Description

The PM(D)S type pilot-controlled PROTEGO® diaphragm valve is a highly developed valve for pressure and vacuum relief. It is primarily used as a safety device for outbreathing in tanks, containers, and process engineering equipment and it also offers reliable protection from vacuum and overpressure. It prevents the intake of air and unacceptable product vapor loss up to the set point. The valve can also be used as inbreathing valve. The main valve is directly controlled when it is exposed to a vacuum; e.g., it functions as a weight-loaded diaphragm valve. This valve is highly suitable under atmospheric conditions and for use in cryogenic service.

The main valve is controlled by a pilot valve. The pilot valve is controlled by the tank pressure. The tank medium does not continuously flow through the pilot. The set pressure is adjusted at the pilot valve by a corrosion-resistant and low-temperature-resistant permanent magnet.

Design Types and Specifications

The valve is equipped with either a control pilot valve or with one control and emergency pilot valve to ensure optimum operating safety in case of malfunctions or damage.

Two different designs are therefore available:

Basic design of pressure/vacuum relief valve with a **PM/S-** control pilot valve

Basic pressure/vacuum relief valve with a control **PM/DS-** pilot valve and additional emergency pilot valve

Additional special devices available upon request.

Table 1: Dimensions

Dimensions in mm / inches

To select the nominal size (DN), use the flow capacity charts on the following pages

DN1	80 / 3"	100 / 4"	150 / 6"	200 / 8"	250 / 10"	300 / 12"	300 / 12"
DN2	100 / 4"	150 / 6"	200 / 8"	250 / 10"	300 / 12"	350 / 14"	400 / 16"
a	225 / 8.86	250 / 9.87	325 / 12.80	375 / 14.76	450 / 17.72	500 / 19.69	500 / 19.69
b	150 / 5.91	175 / 6.89	225 / 8.86	250 / 9.84	270 / 10.63	300 / 11.81	325 / 12.79
c	275 / 10.83	330 / 12.99	445 / 17.52	550 / 21.65	665 / 26.18	785 / 30.91	785 / 30.91
d	370 / 14.57	425 / 16.73	530 / 20.87	605 / 23.82	675 / 26.57	785 / 30.91	835 / 32.87
e	615 / 24.21	685 / 26.97	770 / 30.31	825 / 32.48	935 / 36.81	1005 / 39.57	1055 / 41.53
f	35 / 1.38	40 / 1.57	40 / 1.57	50 / 1.97	50 / 1.97	50 / 1.97	50 / 1.97
g	160 / 6.30	195 / 7.68	250 / 9.84	315 / 12.40	370 / 14.57	425 / 16.73	425 / 16.73

Table 2: Material selection for housing

Design	A	B	Special materials upon request
Housing	Aluminium	Stainless Steel	
Valve seat	Stainless Steel	Stainless Steel	
Sealing	KL-C-4106	KL-C-4106	
Main diaphragm protection	Stainless Steel	Stainless Steel	
Pilot lines	Stainless Steel	Stainless Steel	
Pilot housing	Stainless Steel	Stainless Steel	
Pilot diaphragm	FEP	FEP	

Table 3: Material selection for valve pallet

Design	A	B	C	Special materials upon request
Pressure range (mbar) (inch W.C.)	-3.0 up to -4.0* -1.2 up to -1.6*	-4.0 up to -5.0* -1.6 up to -2.0*	-5.0 up to -7.0* -2.0 up to -2.8*	
Valve pallet	Aluminium	Stainless Steel	Stainless Steel	
Diaphragm	FEP	FEP	FEP	
Diaphragm pallet	Aluminium	Aluminium	Stainless Steel	

* The indicated vacuum ranges depend on the nominal sizes and can differ.
The pressure setting can be combined with any vacuum setting

Table 4: Coefficient of Discharge

DN1	80 / 3"	100 / 4"	150 / 6"	200 / 8"	250 / 10"	300 / 12"	300 / 12"
DN2	100 / 4"	150 / 6"	200 / 8"	250 / 10"	300 / 12"	350 / 14"	400 / 16"
d0	81 / 3.19	107 / 4.21	160 / 6.30	208 / 8.19	260 / 10.24	310 / 12.20	310 / 12.20
K	0.68	0.68	0.63	0.59	0.58	0.54	0.61

DN1 = Size Inlet
DN2 = Size Outlet
d0 = Orifice Diameter (mm / inches)
K = Coefficient of Discharge

Table 5: Flange connection type

EN 1092-1; Form B1	other types upon request
ASME B16.5; 150 lbs RFSF	



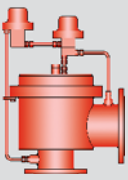

Pressure/Vacuum relief valve

Flow Capacity Charts

PROTEGO® PM/(D)S

* = DN1 300/12" / DN2 350/14"

** = DN1 300/12" / DN2 400/16"

DN1 = DN

DN 80 / 3"

DN 100 / 4"

DN 150 / 6"

DN 200 / 8"

DN 250 / 10"

DN 300 / 12"*

DN 300 / 12"**

airflow in thousands of CFH

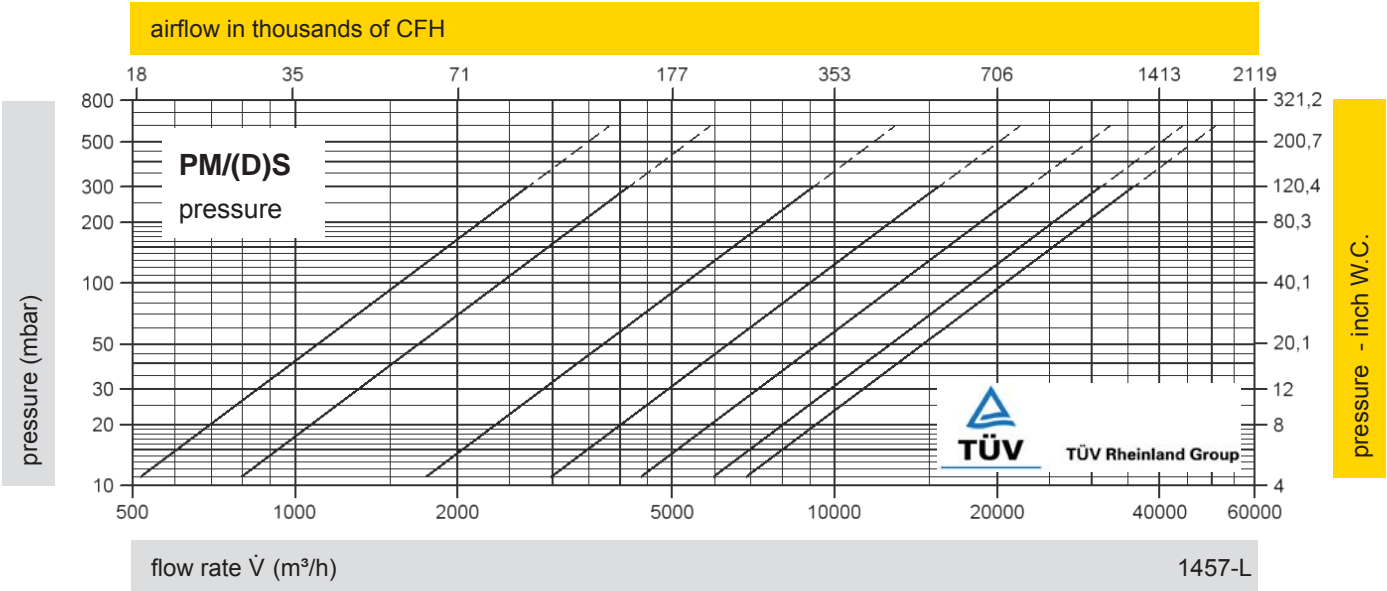

flow rate \dot{V} (m³/h)

1457-L

* = DN1 300/12" / DN2 350/14"

** = DN1 300/12" / DN2 400/16"

DN1 = DN

DN 80 / 3"

DN 100 / 4"

DN 150 / 6"

DN 200 / 8"

DN 250 / 10"

DN 300 / 12"*

DN 300 / 12"**

airflow in thousands of CFH

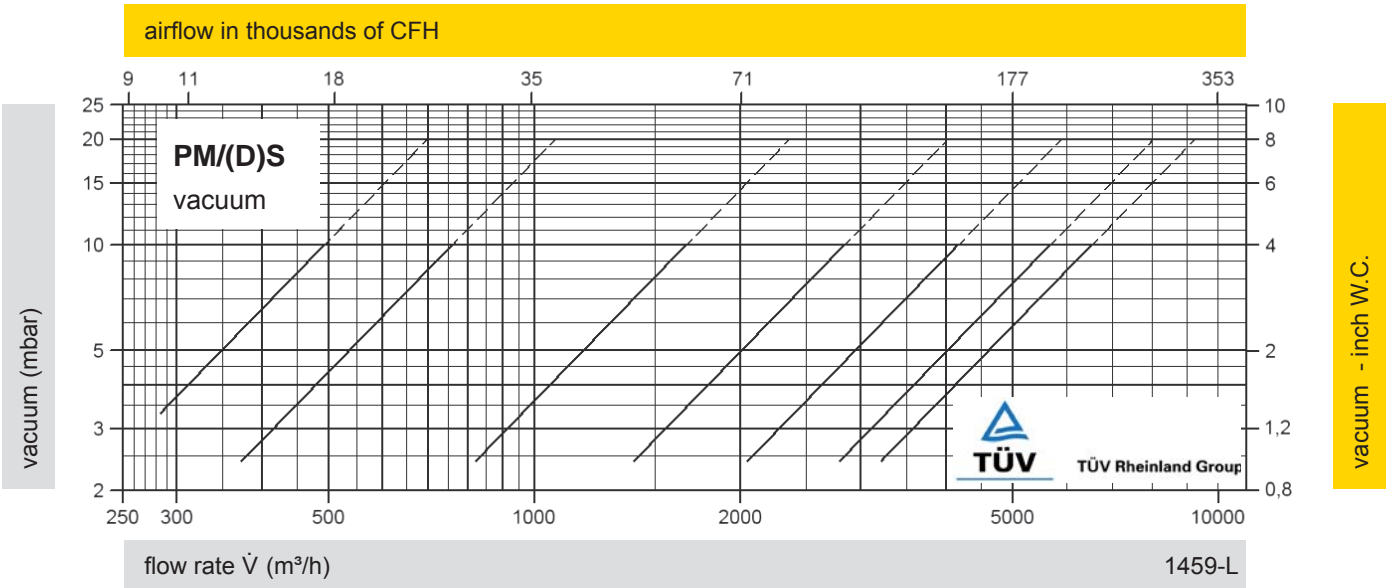

flow rate \dot{V} (m³/h)

1459-L

The flow capacity charts have been determined with a calibrated and TÜV certified flow capacity test rig. Volume flow \dot{V} in (m³/h) and CFH refer to the standard reference conditions of air ISO 6358 (20°C, 1bar). Conversion to other densities and temperatures refer to Vol. 1: "Technical Fundamentals".

Project Data Sheet

Project:

Engineering:

End-user:

relief type:	pressure only	<input type="checkbox"/>			
	pressure and vacuum	<input type="checkbox"/>			
medium:					
boiling point:		°C			
molar mass:		g/mol			
total backpressure:		mbar or inch W.C.			
dynamic backpressure:		mbar or inch W.C.			
static (superimposed) backpressure:		mbar or inch W.C.			
inlet pressure drop:		mbar or inch W.C.			
set pressure:		mbar or inch W.C.			
set vacuum:		mbar or inch W.C.			
material:					
required discharge per valve:		kg/h or lb/hr			
required vacuum capacity per valve at +20°C:		m³/h or SCFH			
flange connection:	ASME	<input type="checkbox"/>	EN 1092-1	<input type="checkbox"/>	JIS <input type="checkbox"/>

Fill in and tick off, if applicable, delete unit, if not applicable.

signed:	date:
---------	-------



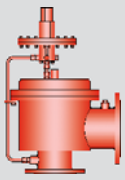

Pressure/Vacuum Relief Valve

Pilot-operated diaphragm valve

PROTEGO® PM-HF

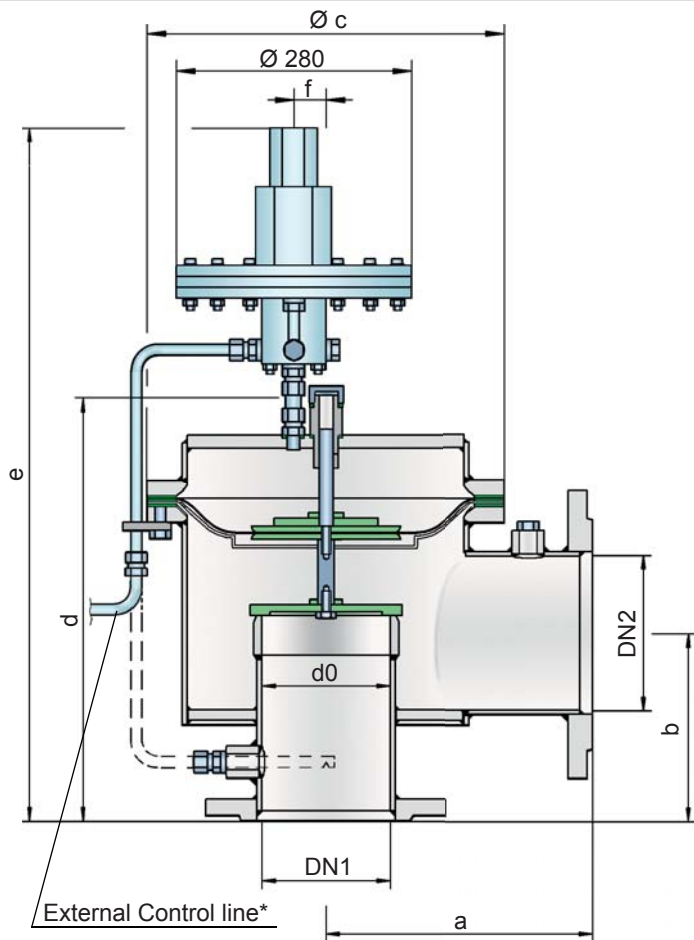

The main valve is controlled by a pilot valve. The latter in turn is controlled by the tank pressure. A small amount fluid stored in the tank released into the atmosphere by the pilot when the valve opens. The set-to-operate pressure is adjusted on the pilot valve by increasing or decreasing (as appropriate) the tension of a spring.

As the working pressure rises, the closing force acting on the main valve increases, i.e. the valve's tight-sealing is enhanced until the set-to-operate pressure is reached, thus preventing leakage. Once the valve has commenced to lift it opens fully within a 10% pressure rise or the opening pressure difference and the nominal volumetric flow is discharged through a fully open valve. If and when this level is exceeded the pressure increase will follow the performance curve ($\Delta p/V$ curve). From set pressure to full capacity (fully open valve) the pressure increase is 100% in case of vacuum venting/inbreathing function.

Due to the sophisticated manufacturing technology, the tank pressure is maintained up to the set-to-operate pressure, with seal-tight requirements far above common standards being met. This feature is achieved through valve seats made of high-grade stainless steel with precisely ground valve pallets. Once the excess pressure is relieved or pressure below atmospheric balanced out, the valve reseats and seals tight again.

Special Features and Advantages

- controlled by corrosion-resistant pilot valve
- small amount fluid stored in the tank released into the atmosphere by the pilot when the valve opens
- max. 10% Technology for minimum pressure increase until full lift
- seals extremely tight; hence, least possible product losses and reduced impact on the environment
- set-to-operate pressure close to the opening pressure; hence, best possible pressure management of the system.
- control diaphragm of the main valve shielded from low temperatures - Long service life
- high flow capacity
- suited for use in hazardous areas
- Field-Test-Connection on request
- Field-Test-Kit on request

Settings:

Pressure:

+10 mbar up to +1034 mbar
+4 inch W.C. up to +413.6 inch W.C.

Vacuum:

-3 mbar up to -7 mbar (DN 80/3")
-1.2 inch W.C. up to -2.8 inch W.C.
-2.2 mbar up to -7 mbar (DN100/4" - DN 300/12")
-0.88 inch W.C. up to -2.8 inch W.C.

Higher or lower settings upon request.

Function and Description

The PROTEGO® Type PM-HF pilot-controlled diaphragm valve is a highly developed valve for pressure and vacuum relief. Primarily used as a safety device for outbreathing in tanks, vessels, and process engineering equipment it also offers reliable protection from vacuum and overpressure. It prevents intake of air and unacceptable product vapor loss up to and until the set-to-operate pressure is reached. The valve can be used as an inbreathing device as well. In such an application, the main valve is directly controlled when exposed to a vacuum, i.e. it functions as a weight-loaded diaphragm valve.

Design Types and Specifications

Basic design of pressure/vacuum relief valve with a **PM-HF** control pilot valve

Additional special devices available upon request.

* It is recommended that an external control line be provided with direct connection to the tank.



Table 1: Dimensions

Dimensions in mm / inches

To select the nominal size (DN), use the flow capacity charts on the following pages

DN1	80 / 3"	100 / 4"	150 / 6"	200 / 8"	250 / 10"	300 / 12"	300 / 12"
DN2	100 / 4"	150 / 6"	200 / 8"	250 / 10"	300 / 12"	350 / 14"	400 / 16"
a	225 / 8.86	250 / 9.87	325 / 12.80	375 / 14.76	450 / 17.72	500 / 19.69	500 / 19.69
b	150 / 5.91	175 / 6.89	225 / 8.86	250 / 9.84	270 / 10.63	300 / 12.81	325 / 12.80
c	275 / 10.83	330 / 12.99	445 / 17.52	550 / 21.65	665 / 26.18	785 / 30.91	785 / 30.91
d	376 / 14.80	429 / 16.89	536 / 21.10	607 / 23.90	678 / 26.69	796 / 31.34	846 / 33.31
e	763 / 30.04	770 / 30.31	923 / 36.34	977 / 38.46	1052 / 41.42	1173 / 46.18	1223 / 48.15
f	35 / 1.38	40 / 1.57	40 / 1.57	50 / 1.97	50 / 1.97	50 / 1.97	50 / 1.97

Table 2: Material selection for housing

Design	A	B	Special materials upon request
Housing	Aluminium	Stainless Steel	
Valve seat	Stainless Steel	Stainless Steel	
Sealing	KL-C-4106	KL-C-4106	
Main diaphragm protection	Stainless Steel	Stainless Steel	
Pilot lines	Stainless Steel	Stainless Steel	
Pilot housing	Aluminium	Aluminium / Stainless Steel	
Pilot diaphragm	FEP	FEP	

Table 3: Coefficient of Discharge

DN1	80 / 3"	100 / 4"	150 / 6"	200 / 8"	250 / 10"	300 / 12"	300 / 12"
DN2	100 / 4"	150 / 6"	200 / 8"	250 / 10"	300 / 12"	350 / 14"	400 / 16"
d0	81 / 3.19	107 / 4.21	160 / 6.30	208 / 8.19	260 / 10.24	310 / 12.20	310 / 12.20
K	0.68	0.68	0.63	0.59	0.58	0.54	0.61

- DN1 = Size Inlet
- DN2 = Size Outlet
- d0 = Orifice Diameter (mm / inches)
- K = Coefficient of Discharge

Table 4: Flange connection type

EN 1092-1; Form B1	other types upon request
ASME B16.5; 150 lbs RFSF	



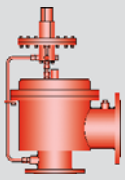

Pressure/Vacuum relief valve

Flow Capacity Charts

PROTEGO® PM-HF

* = DN1 300/12" / DN2 350/14"

** = DN1 300/12" / DN2 400/16"

DN1 = DN DN 80 / 3" DN 100 / 4" DN 150 / 6" DN 200 / 8" DN 250 / 10" DN 300 / 12" * DN 300 / 12" **

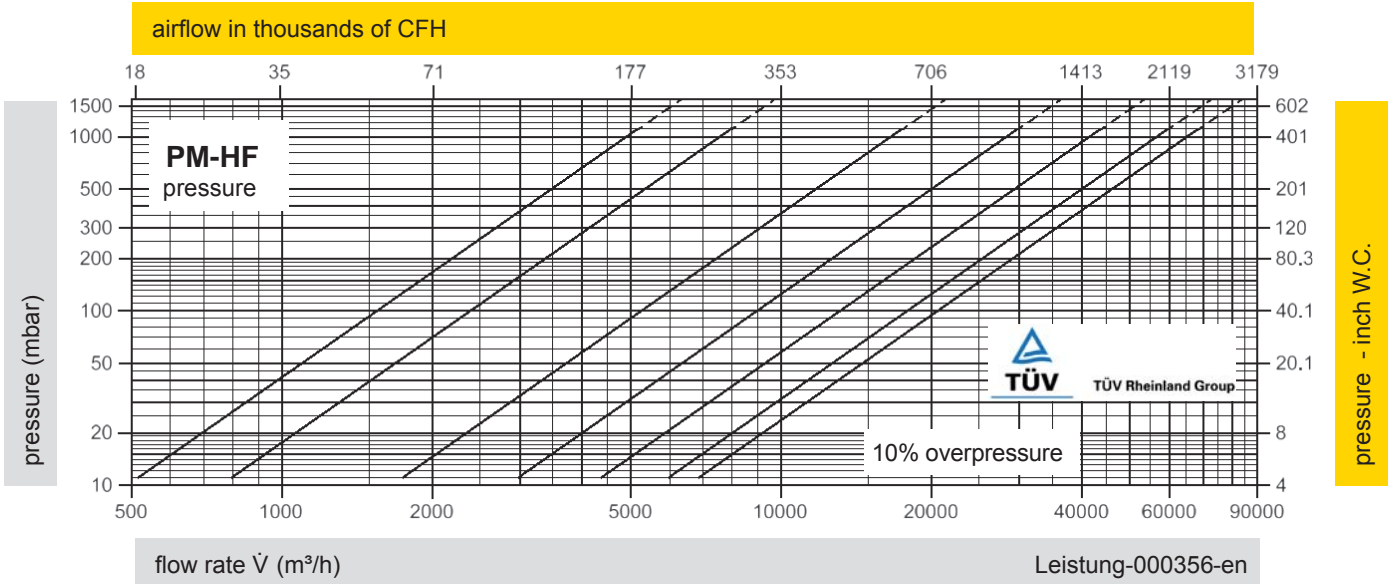

* = DN1 300/12" / DN2 350/14"

** = DN1 300/12" / DN2 400/16"

DN1 = DN DN 80 / 3" DN 100 / 4" DN 150 / 6" DN 200 / 8" DN 250 / 10" DN 300 / 12" * DN 300 / 12" **

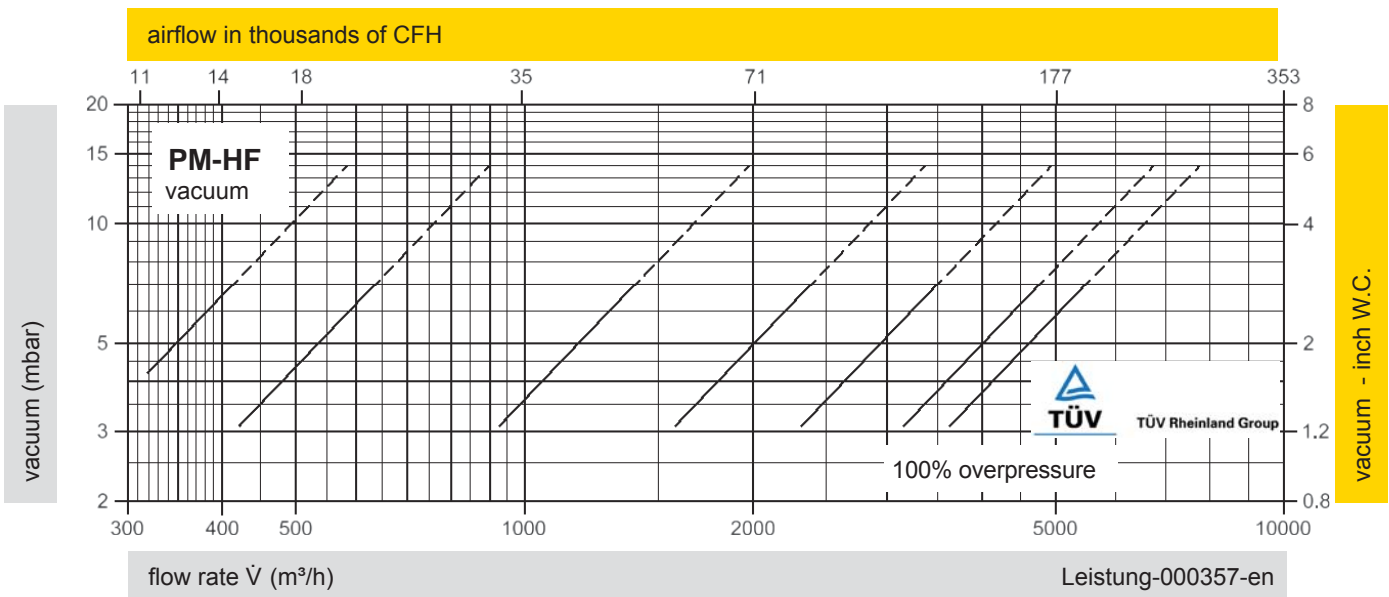

The flow capacity charts have been determined with a calibrated and TÜV certified flow capacity test rig. Volume flow \dot{V} in (m³/h) and CFH refer to the standard reference conditions of air ISO 6358 (20°C, 1bar). Conversion to other densities and temperatures refer to Vol. 1: "Technical Fundamentals".

Project Data Sheet

Project:
Engineering:
End-user:

relief type:	pressure only	<input type="checkbox"/>			
	pressure and vacuum	<input type="checkbox"/>			
medium:					
boiling point:		°C			
molar mass:		g/mol			
total backpressure:		mbar or inch W.C.			
dynamic backpressure:		mbar or inch W.C.			
static (superimposed) backpressure:		mbar or inch W.C.			
inlet pressure drop:		mbar or inch W.C.			
set pressure:		mbar or inch W.C.			
set vacuum:		mbar or inch W.C.			
material:					
required discharge per valve:		kg/h or lb/hr			
required vacuum capacity per valve at +20°C:		m³/h or SCFH			
flange connection:	ASME	<input type="checkbox"/>	EN 1092-1	<input type="checkbox"/>	JIS <input type="checkbox"/>

Fill in and tick off, if applicable, delete unit, if not applicable.

signed:	date:
---------	-------

Vacuum Relief Valve



PROTEGO® V/SV-XL

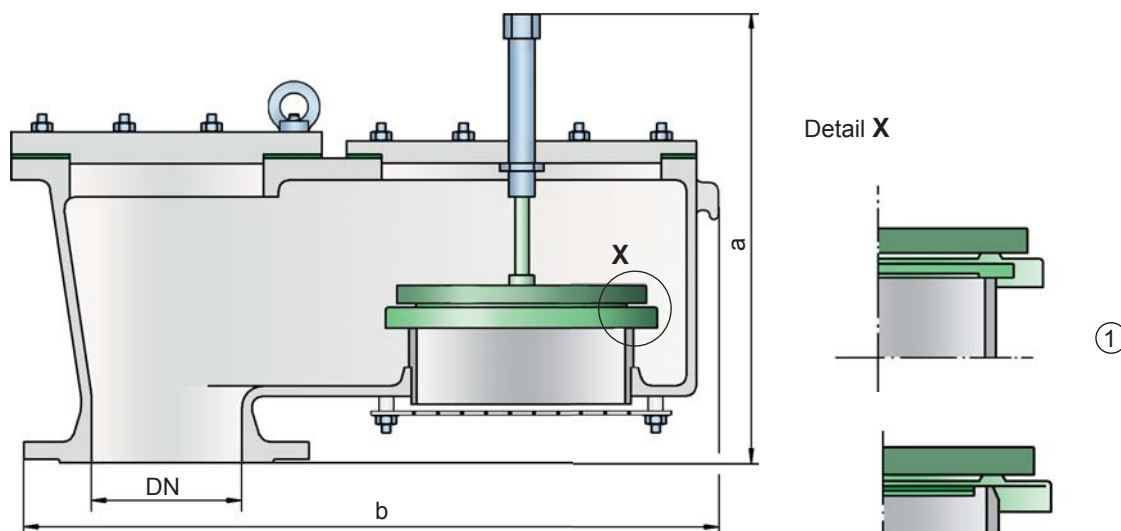

Settings:

Vacuum: -2.0 mbar up to -16 mbar
-0.8 inch W.C. up to -6.4 inch W.C.

Higher vacuum settings upon request.

Function and Description

The V/SV-XL type PROTEGO® valve is a highly developed optimized vacuum relief valve with excellent flow performance. It is primarily used as a safety device for relieving vacuum in tanks, containers and process engineering equipment. The valve offers reliable protection against vacuum, and prevents inbreathing of air close to the set pressure.

The device will start to open as soon as the set pressure is reached and only requires 10% overpressure to full lift. Continuous investments into research and development have allowed PROTEGO® to develop a low pressure valve which has the same opening characteristic as a high pressure safety relief valve. This “full lift type” technology allows the valve to be set just 10% below the maximum allowable working pressure of the tank and still safely vent the required mass flow.

Due to our highly developed manufacturing technology the tank pressure is maintained up to set pressure, with a tightness that is far superior to the conventional standard. This feature is achieved by valve seats made of high quality stainless steel and with precisely lapped valve pallets (1) or with an air cushion seal (2) in conjunction with high quality FEP diaphragm. The valve pallets are also available with a PTFE seal to prevent the valve pallets from sticking when sticky products are used, and they enable the use of corrosive media. After the vacuum is relieved, the valve reseats and provides a tight seal again.

The optimized fluid dynamic design of the valve body and valve pallet is a result of many years of research work, which allow a stable operation of the valve pallet and optimized performance resulting in reduction of product losses.

Special Features and Advantages

- “full lift type” technology valve utilizes only 10% overpressure to reach full lift
- extreme tightness and hence least possible product losses and reduced environmental pollution
- the set pressure is close to the opening pressure which results in best possible pressure management of the system
- high optimized flow capacity
- the valve pallet is guided within the housing to protect against harsh weather conditions
- can be used in areas subject to explosion hazards
- self draining
- maintenance friendly design
- best technology for API-tanks

Design Types and Specifications

The valve pallets are weight-loaded. Higher vacuum can be achieved upon request with a special spring-loaded design.

There are two different designs:

Pressure/vacuum valve in basic design **V/SV-XL -**

Pressure/vacuum relief valve with heating jacket **V/SV-XL -**

Additional special devices available upon request.

Table 1: Dimensions

Dimensions in mm / inches

DN	300 / 12"
a	649 / 25.55
b	946 / 37.24

Dimensions of pressure and vacuum relief valves with heating jacket upon request

Table 2: Material selection for housing

Design	A	B	C	
Housing	Aluminium	Steel	Stainless Steel	Option: Housing ECTFE-coated
Heating jacket (V/SV-XL-H-...)	-	Steel	Stainless Steel	
Valve seat	Stainless Steel	Stainless Steel	Stainless Steel	Special materials upon request
Sealing	PTFE	PTFE	PTFE	
Cover	Aluminium	Steel	Stainless Steel	

Table 3: Material selection for vacuum valve pallet

Design	A	B	C	
Vacuum range (mbar) (inch W.C.)	-2.0 up to -3.0 -0.8 up to -1.2	<-3.0 up to -9.0 <-1.2 up to -3.6	<-9.0 up to -16 <-3.6 up to -6.4	Special material as well as higher vacuum upon request
Valve pallet	Aluminium	Stainless Steel	Stainless Steel	
Sealing	FEP	FEP	Metal to Metal	

Table 4 Flange connection type

EN 1092-1; Form B1	other types upon request
ASME B16.5; 150 lbs RFSF	

Flow Capacity Chart

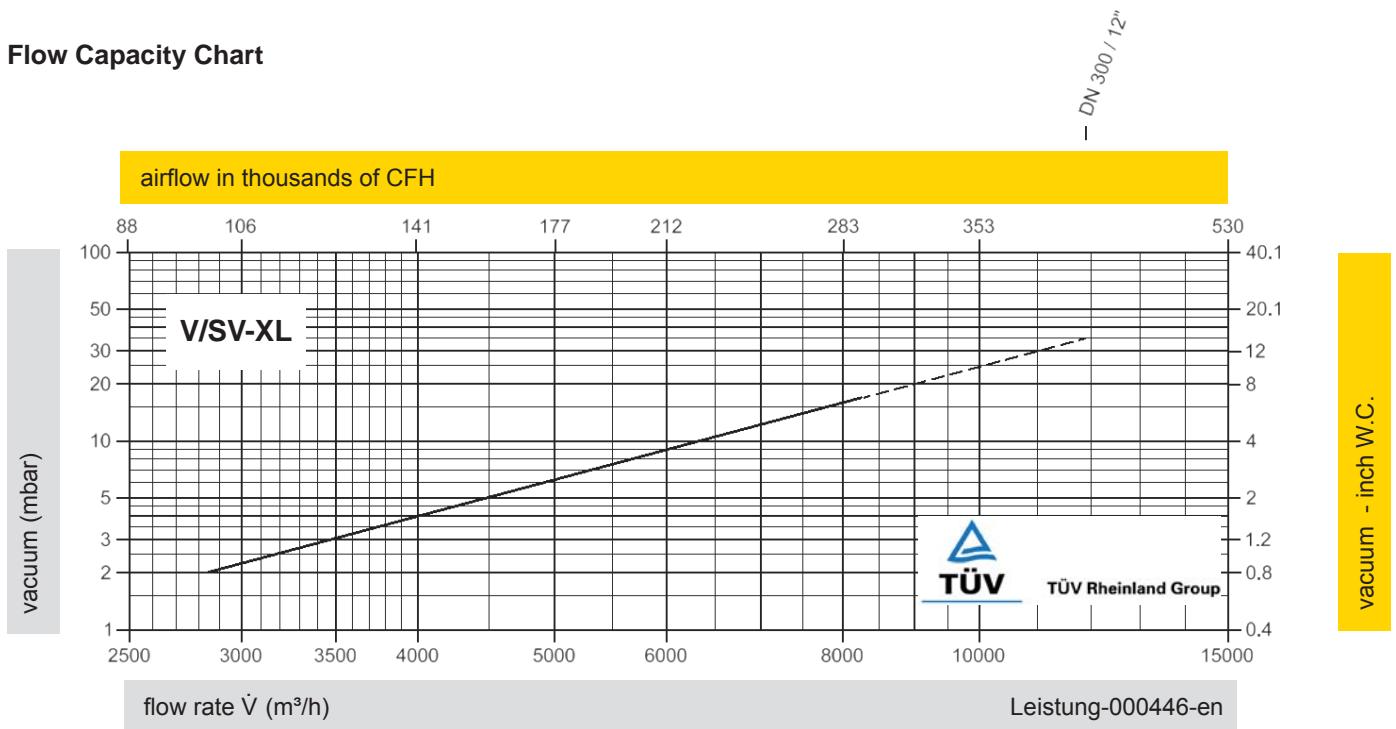

The flow capacity chart has been determined with a calibrated and TÜV certified flow capacity test rig. Volume flow \dot{V} in (m³/h) and CFH refer to the standard reference conditions of air ISO 6358 (20°C, 1bar). Conversion to other densities and temperatures refer to Vol. 1: "Technical Fundamentals".



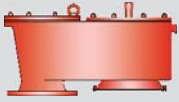

Vacuum Relief Valve



PROTEGO® V/SV-XXL

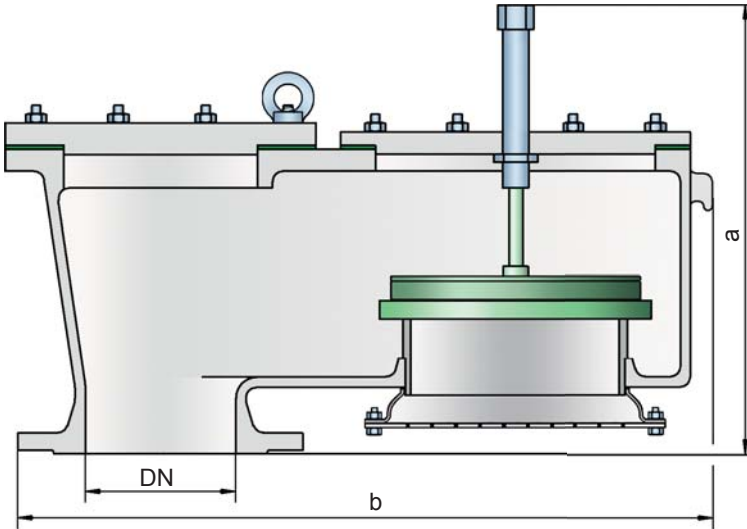

Settings:

Vacuum: -2.0 mbar up to -16 mbar
 -0.8 inch W.C. up to -6.4 inch W.C.

Higher vacuum settings upon request.

Function and Description

The V/SV-XXL type PROTEGO® valve is a highly developed optimized vacuum relief valve with excellent flow performance. It is primarily used as a safety device for relieving vacuum in tanks, containers and process engineering equipment.

When the set vacuum is reached, the valve starts to open and reaches full lift within a 100% vacuum increase. Up to the set vacuum, the tank vacuum is maintained with a seal that is far superior to the conventional standard due to the highly developed manufacturing technology. This feature is achieved by valve seats made of high quality stainless steel with precisely lapped valve pallets and a reinforced housing design. After the vacuum is relieved, the valve reseats and again provides a tight seal.

The optimized fluid dynamic design of the valve body and valve pallet is a result of intensive research and development activities, which allow a stable operation of the valve pallet and optimized performance resulting in reduction of product losses.

Special Features and Advantages

- excellent tightness and hence least possible product losses and reduced environmental pollution
- very high optimized flow capacity
- the valve pallet is guided within the housing to protect against harsh weather conditions
- can be used in areas subject to explosion hazards
- self draining
- maintenance friendly design
- best technology for API-tanks
- designed for use on cryogenic tanks

Design Types and Specifications

The valve pallets are weight-loaded. Higher vacuum can be achieved upon request with a special spring-loaded design.

There are two different designs:

Pressure/vacuum valve in basic design **V/SV-XXL - □**

Pressure/vacuum relief valve with heating jacket **V/SV-XXL - H**

Additional special devices available upon request.

Table 1: Dimensions

Dimensions in mm / inches

DN	300 / 12"
a	649 / 25.55
b	946 / 37.24

Dimensions of pressure and vacuum relief valves with heating jacket upon request

Table 2: Material selection for housing

Design	A	B	C
Housing	Aluminium	Steel	Stainless Steel
Heating jacket (V/SV-XXL-H-...)	–	Steel	Stainless Steel
Valve seat	Stainless Steel	Stainless Steel	Stainless Steel
Sealing	PTFE	PTFE	PTFE
Cover	Aluminium	Steel	Stainless Steel

Option: Housing ECTFE-coated

Special materials upon request

Table 3: Material selection for vacuum valve pallet

Design	A	C
Vacuum range (mbar) (inch W.C.)	-2.0 up to -9.0 -0.8 up to -3.6	<-9.0 up to -16 <-3.6 up to -6.4
Valve pallet	Aluminium	Stainless Steel
Sealing	Metal to Metal	Metal to Metal

Special material as well as higher vacuum upon request

Table 4 Flange connection type

EN 1092-1; Form B1
ASME B16.5; 150 lbs RFSF

other types upon request

Flow Capacity Chart

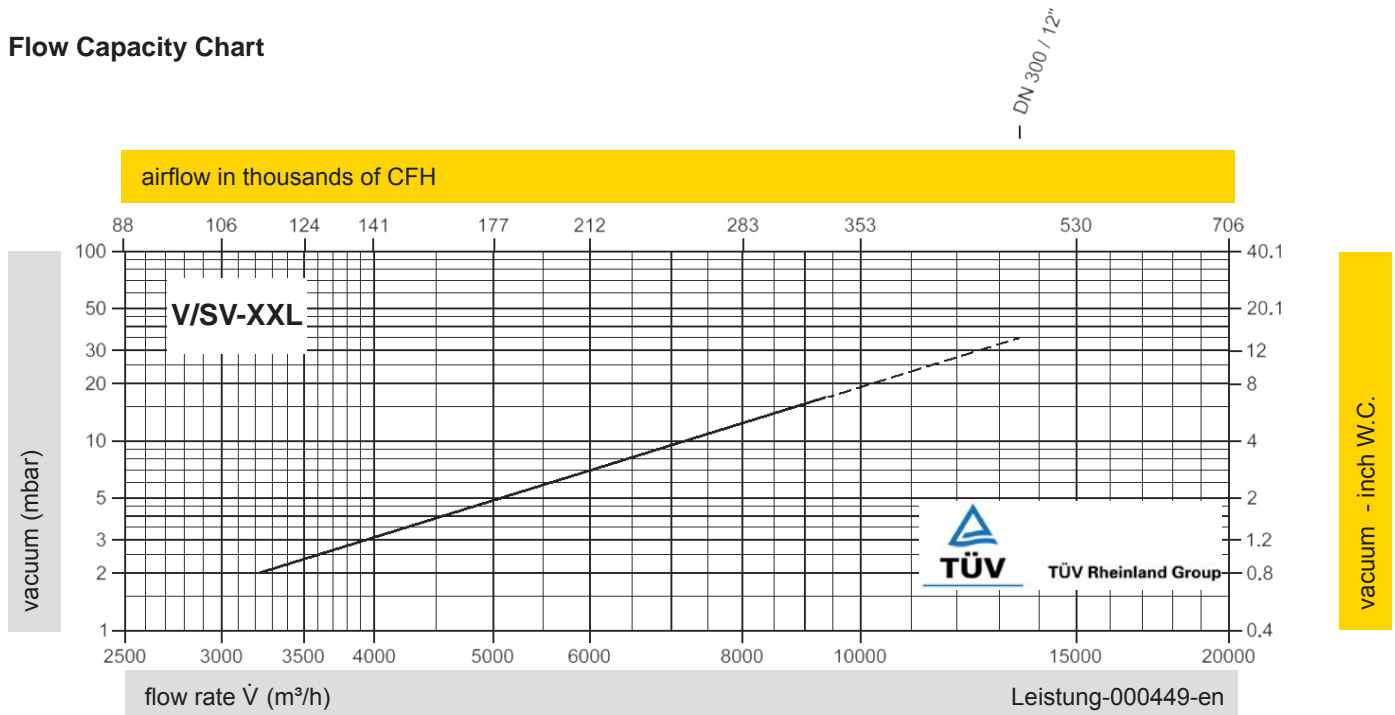

Remark

$$\text{set pressure} = \frac{\text{opening pressure resp. tank design pressure}}{2}$$

Set pressure = the valve starts to open

Opening pressure = set pressure plus overpressure

Overpressure = pressure increase over the set pressure

The flow capacity chart has been determined with a calibrated and TÜV certified flow capacity test rig.

Volume flow \dot{V} in (m³/h) and CFH refer to the standard reference conditions of air ISO 6358 (20°C, 1bar).

Conversion to other densities and temperatures refer to Vol. 1: "Technical Fundamentals".



for safety and environment

Change-Over Valve

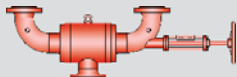

PROTEGO® WV/T

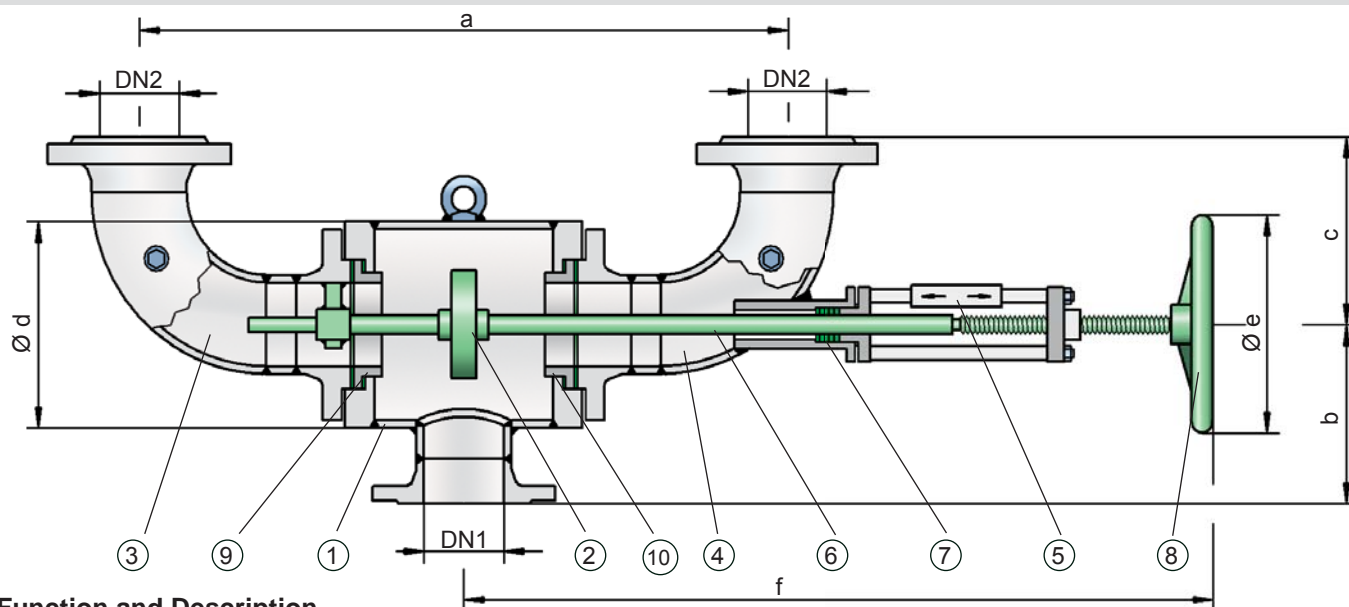

Function and Description

PROTEGO® change-over valves type WV/T are mainly used together with other valves or safety devices (e.g. PROTEGO® flame arresters) on cryogenic storage tanks and on tanks in process plants of chemical, petrochemical and pharmaceutical industries. They increase the operating safety of the technical equipment to be protected because each valve or safety device can be checked, maintained or repaired without any service break-down.

The valves mainly consist of housing (1) with flange connections DN 1 and two lateral connection elbows (3, 4) with flange connections DN 2 and the valve disc (2). If necessary it is possible to displace and turn the connection elbows. The valve seats (9, 10) are replaceable. The valve disc with metallic sealing surface is movable on the valve spindle (6). This ensures good adjustment to the valve seats even with high temperature differences. The sealing between valve disc and valve spindle is provided by an O-ring. The valve spindle is guided by bearing bushings; to the outside it is sealed by an adjustable packing (7).

The change-over valve allows the operator to block one valve or safety device at a time by operating the hand wheel (8). In normal operation the valve disc is in central position and the gas/liquid flows through the two connection elbows. By turning the hand wheel to the stop, one of the connection elbows (3 or 4) is blocked while the other one remains open. The actual position of the valve disc can be identified from the position indicator (5) displayed on the valve spindle.

Depending on the requirements, the change-over valve in normal operation can be in mid-position or in end position: Mid-position, e.g. when a high capacity of relief is required through emergency relief valves controlled in parallel, or end position, e.g. in case of flame arresters which, controlled in parallel, can be used or cleaned alternately as necessary.

Due to their design and appropriately selected materials the valves are distinguished by their high functional safety and very good flow rates. All elements that affect the function are made out of stainless steel.

Because of the variable nozzle positions the design of the PROTEGO® change-over valves WV/T facilitates connection of valves or other safety devices both with angle or straight through connection without additional adaptors.

Positions of nozzles

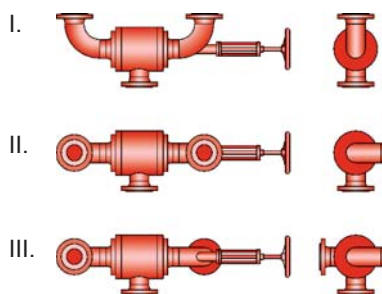

drag coefficient $\zeta = 1,2$ for valve in center position
 $\zeta = 2,6$ if one side of valve closed

Change-over valves of type WV/T stand out by their simple design, easy handling, the option of quick replacement of components that effect the function and consequently by their excellent availability and operational reliability. The lapped metallic sealing surfaces ensure a high degree of tightness even in low temperature ranges.

These valves are not flame transmission proof and do not refer to the European Explosion Protection Directive 94/9/EC, even if installed in explosive atmospheres.

A hazard analysis (which considers the material selection and function of the device) shows that the device doesn't have any potential sources of ignition.

Design Types and Specifications

Special devices in heatable design can be used under specific operating conditions:

- with crystallizing products or products which tend to form deposits that affect the function
- in use under extreme weather conditions in winter (frost), when product vapour might condensate in the undercooled valve, so ice bridges could develop, which could probably block the valve disc

Table 1: Dimensions					Dimensions in mm / inches		
DN1	80 / 3"	100 / 4"	150 / 6"	200 / 8"	200 / 8"	250 / 10"	300 / 12"
DN2	80 / 3"	100 / 4"	150 / 6"	150 / 6"	200 / 8"	250 / 10"	300 / 12"
a	780 / 30.71	780 / 30.71	960 / 37.80	960 / 37.80	1130 / 46.12	1450 / 57.09	1650 / 64.96
b	250 / 9.84	250 / 9.84	310 / 12.20	310 / 12.20	330 / 13.47	360 / 14.17	415 / 16.34
c *	303 / 11.93	205 / 8.07	285 / 11.22	285 / 11.22	367 / 14.98	450 / 17.72	525 / 20.67
c**	323 / 12.72	230 / 9.06	317 / 12.48	317 / 12.48	407 / 16.02	483 / 19.01	571 / 22.48
d	273 / 10.75	273 / 10.75	324 / 12.76	324 / 12.76	355 / 14.49	457 / 17.99	500 / 19.68
e	250 / 9.84	250 / 9.84	250 / 9.84	250 / 9.84	400 / 16.33	400 / 15.75	500 / 19.68
f	905 / 35.63	905 / 35.63	1070 / 42.13	1070 / 42.13	1080 / 42.52	1515 / 59.65	1655 / 59.65
f _{min}	810 / 31.89	810 / 31.89	950 / 37.40	950 / 37.40	1170 / 47.76	1360 / 53.54	1470 / 57.87
f _{max}	995 / 39.17	995 / 39.17	1190 / 46.85	1190 / 46.85	1310 / 53.47	1695 / 66.73	2015 / 79.33

* for connection flange DIN PN16 resp. from DN 200 DIN PN 10

** for connection flange ANSI 150 lbs

Table 2: Material selection		
Design	A	B
Housing and connection elbows	Steel	Stainless Steel
Valve disc	Hastelloy	Hastelloy
Packing	PTFE	PTFE
Spindle sealing	FPM	FPM
Handwheel	Steel	Steel

The connection flange material must be compatible to the material of the plant component. Special models of change-over valves are available for specific requirements.

Table 3: Flange connection type DN	
EN 1092-1, Form B1	other types upon request
ASME B16.5; 150 lbs RFSF	

Selection and Design

Together with the customer our engineers design and specify the valve for the specific case. The relevant plant specification is taken into account when defining the required nominal sizes and connection types. In standard versions the maximum allowable service temperature is +200°C / 392°F under a maximum allowable operating pressure of 6 bar / 87 psi. The device must have sufficient corrosion resistance with regard to the media to be stored or transported. If necessary, designs in special stainless steel quality should be selected.

Necessary Data for Specification

- Stored medium
- Service temperature (°C or °F)
- Operating pressure (bar or psi)
- Tank material
- Tank nozzle DN1 (mm or inches)
- Tank nozzle DN2 (mm or inches)
- Position of nozzle I, II or III





In-tank Valve

with pneumatic actuator

PROTEGO® NB/AP

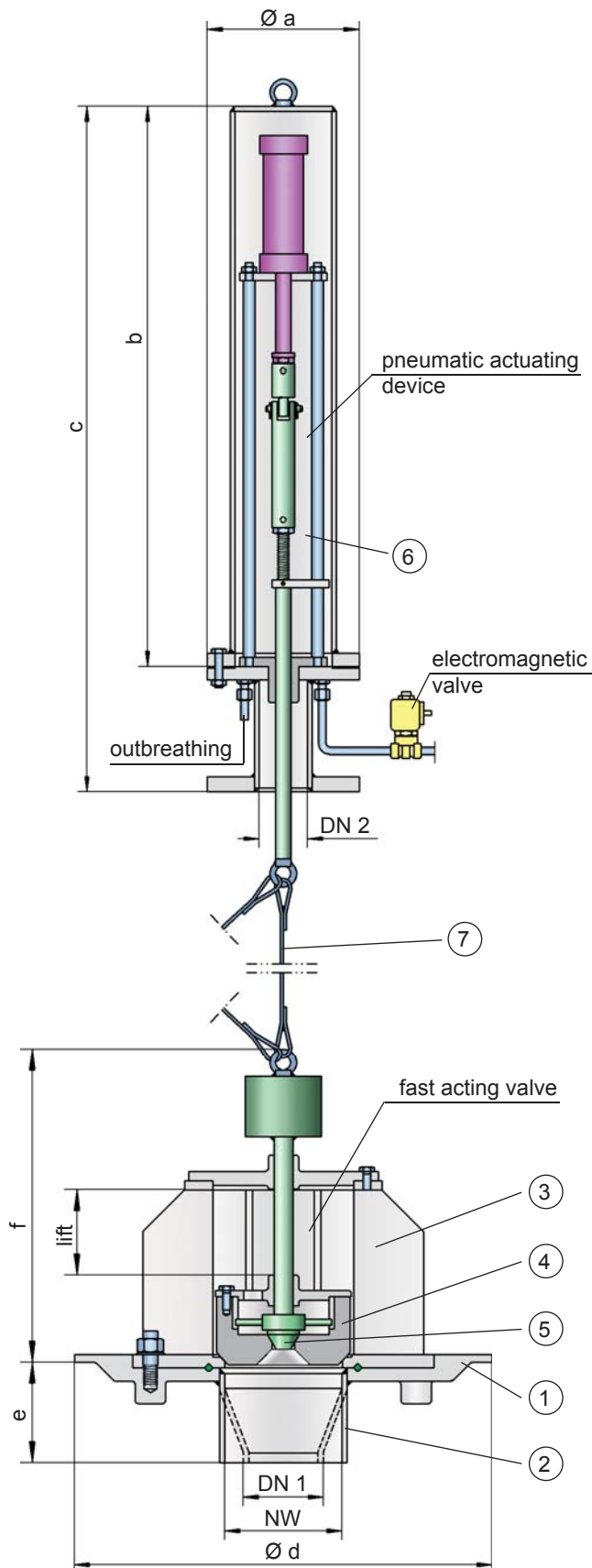

If fast acting valve is open, drag coefficient amounts to 1,5

Function and Description

In-Tank Valves such as the PROTEGO® NB/AP are used in storage tanks for cryogenic liquids in order to seal off discharge lines in the event of an accident or emergency (pipe bursting). These devices comply with the requirements of API 625.

The device consists of the bottom plate (1), which has to be welded onto the vessel bottom, a nozzle (2), which is to be welded to the discharge line and the flanged fast acting valve (3) with valve piston (4) and release valve cone (5) and the complete pneumatic actuating device (6), which is mounted to the roof of the tank. Through lapped metallic valve pallet and release vent cone the required leak tightness is achieved.

The fast acting valve (3) and the actuator system (6) are connected by an actuator rope (7). An additional emergency rope allows the opening of the fast acting valve if the main actuator rope is damaged.

During normal operation a pneumatic cylinder holds the device in the open position. The pneumatic cylinder is actuated by a control line to lift the valve piston. In case of emergency, the bottom assembly will rapidly close. This is achieved by interrupting the energy supply to the actuating unit, which will cause the valve piston to fall on the valve seat using the deadweight of the valve pallet (fail safe concept).

The design of the device is independent of the nominal diameter. The nominal diameter DN 1 is preset by the nominal diameter of discharge line.

Material selection is in accordance to the product and the operating temperature.



Design Types and Specifications

Table 1: Dimensions									Dimensions in mm / inches
NW	DN 1	DN 2	a	b	c	d	e	f	Hub
150 / 6"	100 / 4"	80 / 3"	200 / 7.87	1130 / 44.49	1430 / 56.30	550 / 21.65	155 / 6.10	465 / 18.31	160 / 6.30
150 / 6"	150 / 6"	80 / 3"	200 / 7.87	1130 / 44.49	1430 / 56.30	550 / 21.65	175 / 6.89	465 / 18.31	160 / 6.30
200 / 8"	200 / 8"	80 / 3"	200 / 7.87	1130 / 44.49	1430 / 56.30	600 / 23.62	175 / 6.89	470 / 18.50	160 / 6.30
250 / 10"	250 / 10"	80 / 3"	200 / 7.87	1130 / 44.49	1430 / 56.30	740 / 29.13	175 / 6.89	485 / 19.09	160 / 6.30

Table 2: Material of fast action bottom drain valve	
Bottom plate with nozzle	*
Valve housing with valve cone	Stainless Steel
Gasket	*
Actuator rope	Stainless Steel

* upon request

Table 3: Material of actuating device	
Housing	Stainless Steel
Actuator spindle	Stainless Steel
Guide bushing	Brass
Gasket	PTFE
Protective cap	Stainless Steel
Pneumatic cylinder	Aluminium

Table 4: Flange connection type DN 2
EN 1092-1, Form B, PN 40 or upon request

Selection and Design

The main process data and product properties of the stored medium as well as the temperature of the stored product determine the material for the specific valve. Subsequently the **nominal diameter** and the **type of connection** are checked and selected.

The In-Tank Valve is available in nominal diameters of DN 100/4" to DN 250/10", whereas the connection for the pneumatic actuating device has a nominal diameter of DN 80/3".

The length of the actuator rope and of the emergency rope is determined by the height of the tank. The final adjustment is completed during installation.

The standard material of bottom plate is stainless steel. Other materials of construction are available on request.

The position is indicated by inductive proximity switches. The control and regulation devices can be projected and provided upon customer request.

Necessary Data for Specification

- Stored medium
- Operating temperature T (°C or °F)
- Operating pressure p (bar or psi)
- Connection size DN 1
- Tank height (m or ft)

Application Example

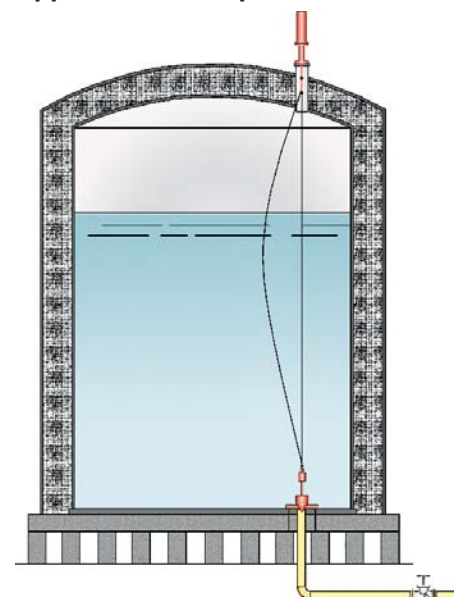



In-tank Valve with pneumatic actuator

PROTEGO® ITV-S



Download Flyer
In-Tank Valves

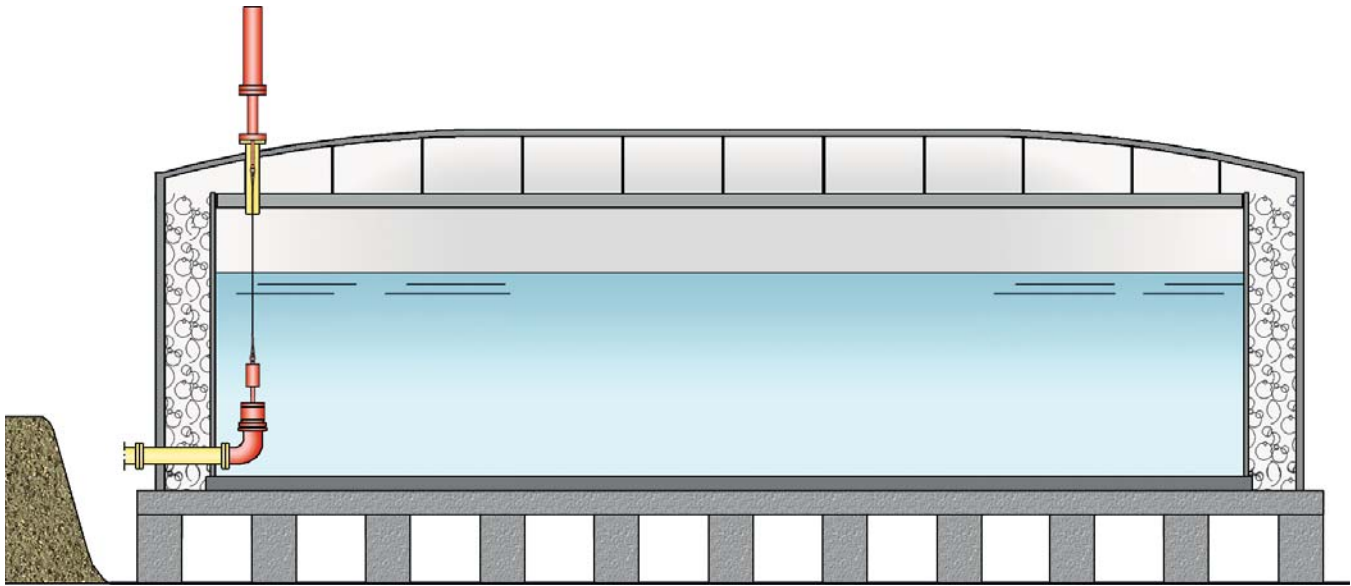

Function and Description

In-Tank Valves such as the PROTEGO® ITV-S are used in storage tanks for cryogenic liquids in order to seal off discharge lines in the event of an accident or emergency. These devices comply with the requirements of API 625.

The PROTEGO® ITV-S consists of a valve guide unit and valve seat which is mounted (flanged) on the inner tank wall via an elbow. When the unit actuates, the valve piston is lifted up and guided over the entire lift stroke. The seal between the valve seat and the valve disk is achieved by finely lapping both surfaces to achieve maximum tightness.

The actuating unit, installed on the tank roof, is specifically designed to the requirements of the application in order to actuate the valve pallet assembly by using suitable ropes or similar connecting elements.

During normal operation, the valves are kept in the open position. In case of emergency, the bottom assembly will rapidly close. This is achieved by interrupting the energy supply to the actuating unit, which will cause the valve piston to fall on the valve seat using the deadweight of the valve pallet (fail safe concept).

The design of the PROTEGO® ITV-S provides the tank designer the following benefits:

- Very light and compact design
- Connection through the tank wall via flange connection
- No support or stroke guide required in the tank
- Low actuating forces required for lifting the valve piston
- Extremely high valve seat tightness thanks to a lapped metal to metal seal

Design and Specification

The standard material of construction for the PROTEGO® ITV-S is stainless steel. Other materials of construction are available on request or depending on the operating data. The design is custom made to each application

Required Information for the custom made Design.

Solutions are available from DN250/10" to DN600/24".



In-tank Valve

Internal Safety Valve

PROTEGO® SI/DP

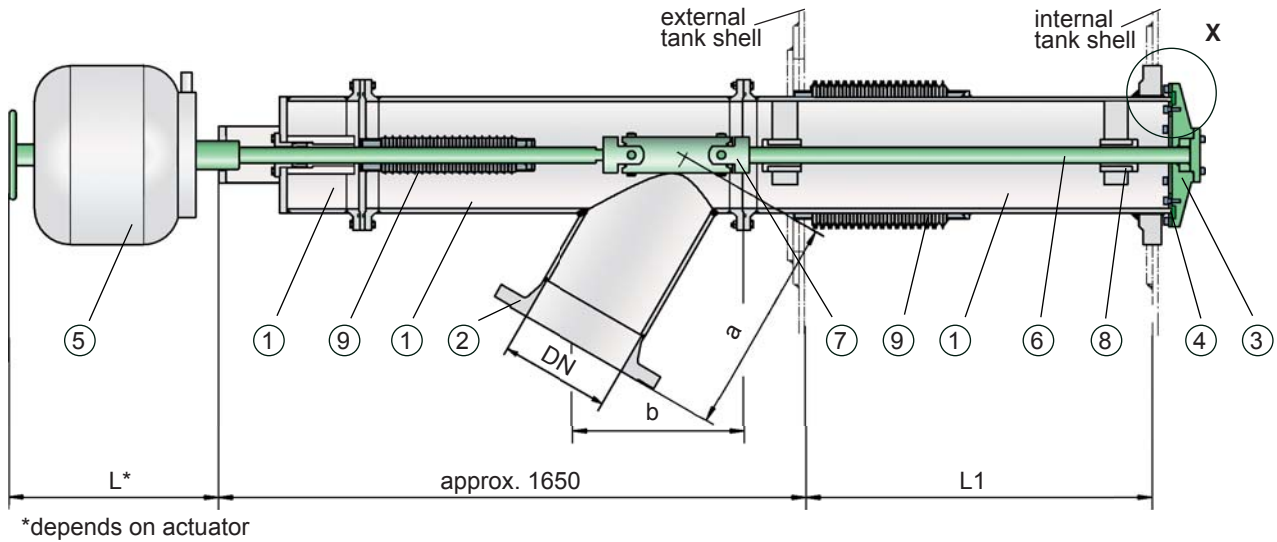

*depends on actuator

Function and Description

PROTEGO® SI/DP in-tank valves are used as additional shut-off valves for full containment tank systems, e.g. for storing liquefied gases, cryogenic gases, other low temperature products or chemicals.

Generally a gate valve that is supplied by the user and serves for normal operation is connected to the external nozzle of the housing. During normal operation, the valves are kept in the open position. It is only closed in case of emergency or for necessary repairs to the gate valve.

The key feature of these valve devices is the actual shut-off element that is located inside the tank.

The internal safety valve consists of three housing parts (1) with lateral connecting nozzle (2) for installation of pipeline, valve cone (3) with sealing (4) and pneumatic actuator (5). Required tightness (refer to detail X) is guaranteed by grounded valve seat (10) and gasket. Bushings (8) guide the split valve spindle (6), which is equipped with double Cardan joint (7). Two compensators (9) are provided to support the length modification resulting from temperature variations.

The in-tank valve is operated / opened by a pneumatic actuator. The necessary force for closing the valve is generated by compression springs of adequate size built into the actuator. The controls must be designed in such a way that in the event of any fault, e.g. loss of control media (compressed air for the actuator and/or electrical power for the 3-way solenoid valve), the internal safety valve automatically closes tight.

By attaching an additional component the in-tank valve can also be operated, e.g. opened and closed, via a hand wheel. This attachment needs to be removed for the valve to operate automatically.

Type SI/DP by PROTEGO® is available in a range of nominal sizes. Optionally, the internal safety valve can be equipped with an internal nozzle to connect to a suction and filling pipe or a swing pipe system.

Detail X

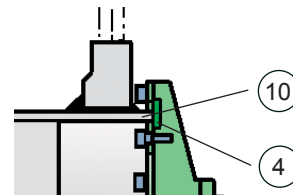



Download Flyer
In-Tank Valves

Designs and Specifications

Table 1: Dimensions		Dimensions in mm / inches	
DN	a	b	
150 / 6"	300 / 11.81	350 / 13.78	
200 / 8"	400 / 15.75	400 / 15.75	
250 / 10"	500 / 19.68	450 / 17.72	
300 / 12"	600 / 23.62	500 / 19.68	

Table 2: Materialselection	
Design	A
Housing	Stainless Steel
Valve disc	Stainless Steel
Valve spindle	Stainless Steel
Spindle sealing	PTFE
Bushing	PTFE
O-rings	PTFE

Table 3: Flange connection type DN	
EN 1092-1, Form B1	other types upon request
ASME B16.5; 150 lbs RFSF	

Selection and Design

Together with the customer our engineers design and specify the valve for each specific application. The relevant plant specifications are taken into account when defining the required nominal sizes and connection types. Also the operating temperature and resulting special operating conditions may require special materials. The mounting flange material must be compatible with the tank material. If there are special requirements for the valve or operating parameters please contact us: If necessary we will arrange for special designs.

Necessary Data for Specification

Stored medium

Tank height/Tank diameter (m or ft)

Jacket space L1

Tank material

Connection diameter of drain pipe, DN (mm or inch)

Application Example

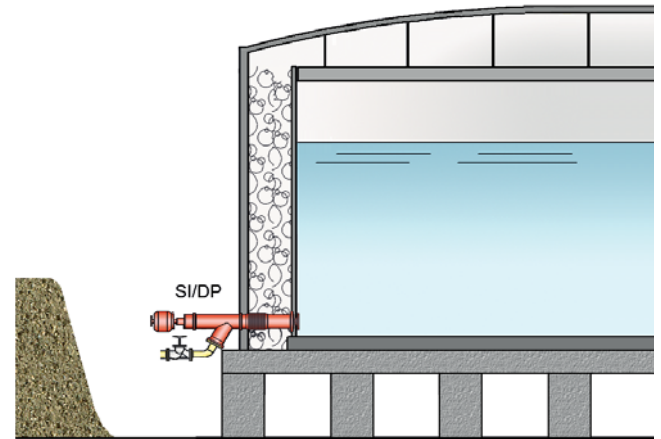

In-tank valve PROTEGO® SI/DP for a full containment tank system as per API 625.

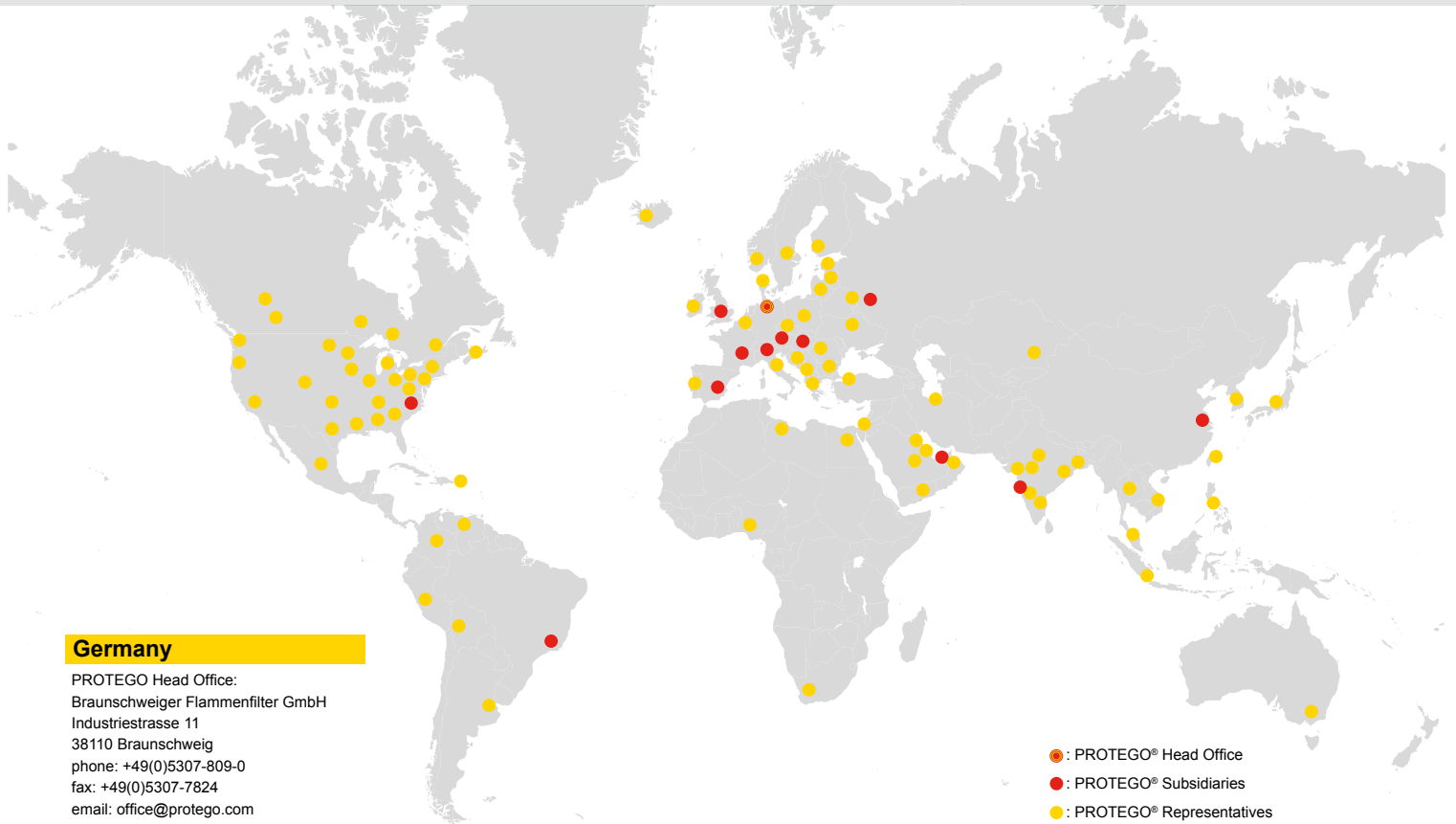

Germany

PROTEGO Head Office:
 Braunschweiger Flammenfilter GmbH
 Industriestrasse 11
 38110 Braunschweig
 phone: +49(0)5307-809-0
 fax: +49(0)5307-7824
 email: office@protego.com

Russia

PROTEGO RUS
 Teterinsky pereulok 4, building 1
 Moscow 109004
 Russian Federation
 phone: +7-49 56 63 36 69
 fax: +7-9 15 0 39 10 06
 email: russia-office@protego.com

USA

PROTEGO (USA) Inc.
 497 Jessen Lane
 Charleston, SC 29492
 phone: +1-843-284 03 00
 fax: +1-843-284 03 04
 email: us-office@protego.com

Spain

PROTEGO España
 Pintor Serra Santa, 19
 08860 Castelldefels
 phone: +34-93-6 34 21 65
 fax: +34-93-6 34 25 45
 email: es-office@protego.com

Great Britain

PROTEGO UK Ltd.
 Studio 1, Europa House Europa Way Britannia
 Enterprise Park
 Lichfield, Staffordshire, WS14 9TZ
 phone: +44-15 43-42 06 60
 fax: +44-15 43-42 06 63
 email: uk-office@protego.com

Switzerland

Ramseyer AG
 Industriestrasse 32
 3175 Flamatt
 phone: +41-31-7 44 00 00
 fax: +41-31-7 41 25 55
 email: info@ramseyer.ch

Hungary

PROTEGO Ungarn Kft.
 3515 Miskolc
 Berzsényi D. u. 26.
 phone: +36-46-381 815
 fax: +36-46-381 816
 email: protego@t-online.hu

France

S.I.D. Steiblé Ingenierie et Distribution SARL
 4 avenue de Strasbourg
 ZAC des Collines
 68350 Didenheim
 phone: +33-3-89 60 62 70
 fax: +33-3-89 60 62 75
 email: info@sid-steible.fr

Austria

PROTEGO
 Armaturen- und Apparatechnik Ges.m.b.H
 Grossmarktstrasse 7C
 1230 Wien
 phone: +43-(0)1 890 15 28-16
 fax: +43-(0)1 890 15 28-12
 email: office@protego.co.at

Middle East

PROTEGO Middle East FZE
 FZSI BL05
 JAFZ, Dubai, U.A.E.
 P.O. Box 261505
 phone: +971-4-88 600 95
 fax: +971-4-88 600 96
 email: sanjiv.advani@protego.com

Brasil

PROTEGO Brasil
 Válvulas e Corta Chamas Ltda.
 Rua Montevidéu, 486 - Penha
 CEP 21020-290 Rio de Janeiro RJ
 phone: +55-21-2112 5700
 fax: +55-21-2112 5723
 email: protegobrasil@protego.com

China

PROTEGO (Nanjing) Safety Equipment LTD
 123 Linqi Road
 Dongshang International Business R&D Park
 211103 Nanjing
 phone: +86-25-8717 9277
 fax: +86-25-8717 9278
 email: yan.zhang@protego.cn

India

PROTEGO India Pvt. Ltd.
 R-665, TTC. Industrial Area MIDC, Rabale
 Navi Mumbai, 400 701
 phone: +91-22-27 69 11 56
 fax: +91-22-27 69 20 85
 email: protegoindia@protego.com

www.protego.com



for safety and environment