



The correct valve selection creates security

Within the various areas of application, valves are subject to widely different requirements. Chemical and physical properties of the working media have a direct influence on material selection of the components. Moreover, both mechanical and process-specific requirements have an immediate effect on the valve. To do justice to the given operating conditions on an individual basis, GEMÜ offers its customers a wide range of valve types as well as many material, connection and actuation options. Basically, the manufacturer's information and the interaction between the operating pressure / temperature must be taken into account.

GEMÜ is your valve and instrumentation partner. State-of-the-art factory equipment and machinery plus a motivated team ensure the best service. A world-wide network of distributors and sales subsidiaries guarantee that products and services reach you quickly and directly. We are constantly making investments in order to optimise our existing products and to develop new products. Thus we can provide technical solutions for individual applications.

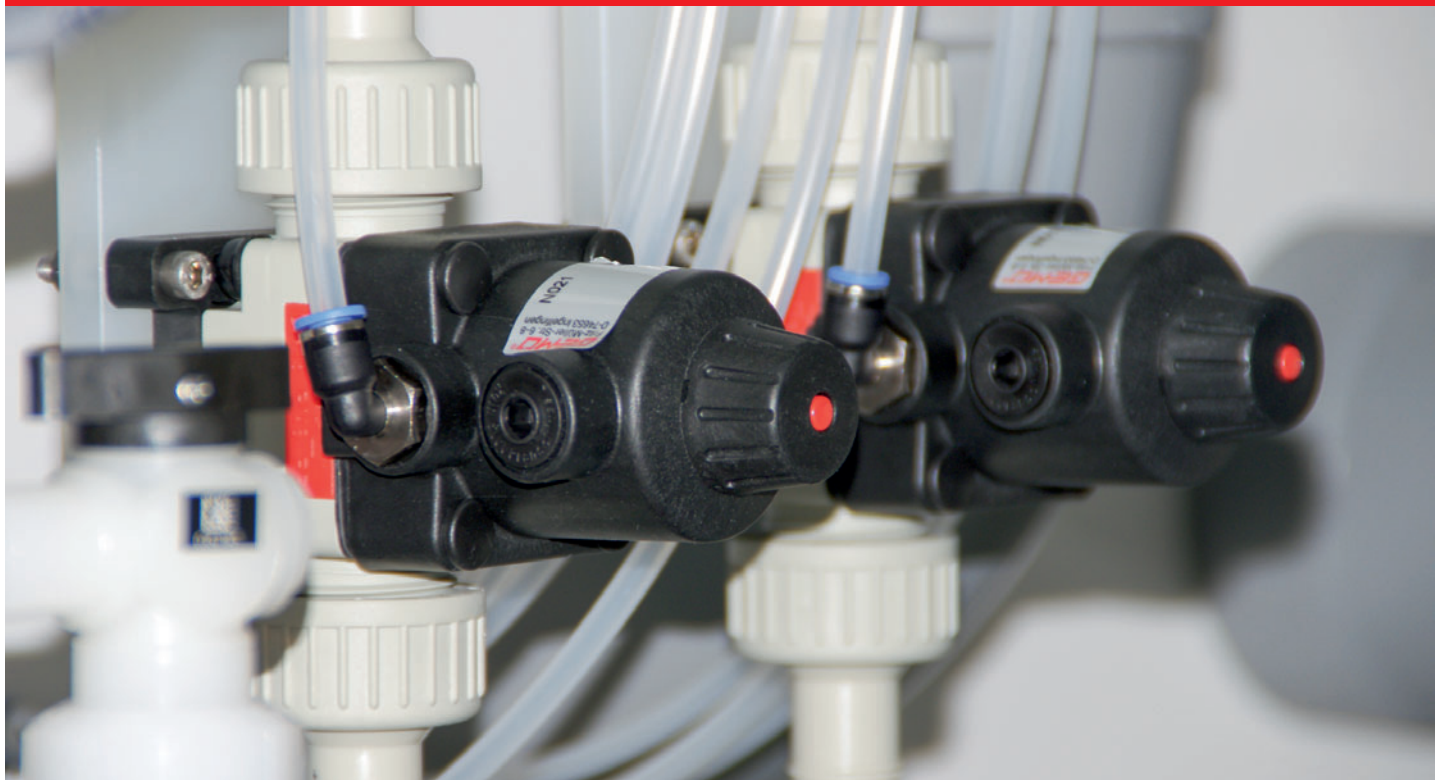

Table of contents

Diaphragm valves DN 12 to 100 Product overview	4 - 5	GEMÜ PurePlus Ultra pure PVDF/PP diaphragm valves	20 - 21
The original GEMÜ seal system.	6 - 7	GEMÜ iComLine Ultra pure PTFE diaphragm globe valves	22 - 23
GEMÜ diaphragms Soft elastomer and PTFE	8	Butterfly valves	24 - 26
GEMÜ 617 / 610 / 613 Diaphragm valves	9	Ball valves	27 - 28
GEMÜ R677 / R690 / R647 Diaphragm valves	10	Angle seat valves	29 - 30
GEMÜ R680 / R693 Diaphragm valves	11	Positioners and process controllers - Overview	31
GEMÜ 1041 Compensating/mounting plates Other accessories	12 - 13	Combi switchboxes and electrical position indicators	32 - 34
Multi-port valve blocks	14	Pilot valves and valve manifolds	35
GEMÜ 563 Globe valve	15	Solenoid valves	36 - 38
Plastic diaphragm valves for ultra pure media	16	GEMÜ Pressure control valves	39 - 40
GEMÜ CleanStar Ultra pure PFA and PP diaphragm valves	17 - 19	Flowmeters	41 - 45
		Overview of plastic materials	46 - 50
		Worldwide Service	51

Diaphragm valves DN 12 to 100

Product overview



Type	GEMÜ 617	GEMÜ R677	GEMÜ 610	GEMÜ R690
Operator	manual	manual	pneumatic	pneumatic
Nominal size	DN 12 to 20	DN 15 to 100	DN 12 to 20	DN 15 to 100
Connection type	Spigots for welding, threaded spigots for unions with insert, threaded and solvent cement sockets, flare connection with union nut	Spigots for solvent cementing and welding, flanges, threaded spigots for unions with insert	Spigots for welding, threaded spigots for unions with insert, threaded and solvent cement sockets, flare connection with union nut	Spigots for solvent cementing and welding, flanges, threaded spigots for unions with insert Different standards and designs available
Valve body material	PVC-U grey, PP reinforced, PP-H natural, PVDF	PVC-U grey, ABS, PP reinforced, PVDF	PVC-U grey, PP reinforced, PP-H natural, PVDF	PVC-U grey, ABS, PP reinforced, PVDF, inliner PP-H, grey / outliner PP reinforced, inliner PVDF / outliner PP reinforced
Media temperature *	-10 to 80 °C	-10 to 80 °C	-10 to 80 °C	-10 to 80 °C
Operating pressure *	0 to 6 bar	0 to 10 bar	0 to 6 bar	0 to 10 bar
Diaphragm material	EPDM, FPM, NBR, PTFE	EPDM, FPM, NBR, PTFE	EPDM, FPM, NBR, PTFE	NBR, FPM, EPDM, PTFE
Voltage	-	-	-	-

* depending on version and/or operating parameters

Elastomer diaphragms

diaphragm sizes 10 to 100
choice of EPDM, NBR, FPM



PTFE diaphragms

diaphragm sizes 10 to 100
PTFE/EPDM laminated





GEMÜ R647	GEMÜ R680	GEMÜ 613	GEMÜ R693
pneumatic	motorized	motorized	motorized
DN 15 to 50	DN 15 to 25	DN 12 to 15	DN 15 to 50
Spigots for solvent cementing and welding, flanges, threaded spigots for unions with insert Different standards and designs available	Union ends with insert	Threaded sockets, solvent cement sockets, spigots for IR butt welding, union ends with insert	Spigots for socket or butt welding, flanges, union ends with insert
PVC-U grey, ABS, inliner PP-H, grey / outliner PP reinforced, inliner PVDF / outliner PP reinforced	PVC-U grey, ABS, inliner PP-H, grey / outliner PP reinforced, inliner PVDF / outliner PP reinforced	PVC-U grey, PP reinforced, PVDF	PVC-U grey, ABS, PVDF, inliner PP-H, grey / outliner PP reinforced
-10 to 80 °C	-20 to 80 °C	-10 to 80 °C	-10 to 80 °C
0 to 6 bar	0 to 6 bar	0 to 6 bar	0 to 10 bar
NBR, FPM, EPDM	NBR, FPM, EPDM, PTFE	NBR, FPM, EPDM, PTFE	FPM, EPDM, PTFE
-	24 V DC	24 VDC, 120 VAC, 230 VAC 50/60Hz	24 VDC, 120 VAC, 230 VAC 50/60Hz

Valve body versions



Backing flanges



Union ends



Butt weld spigots



Customised multi-port valve blocks

The original GEMÜ seal system

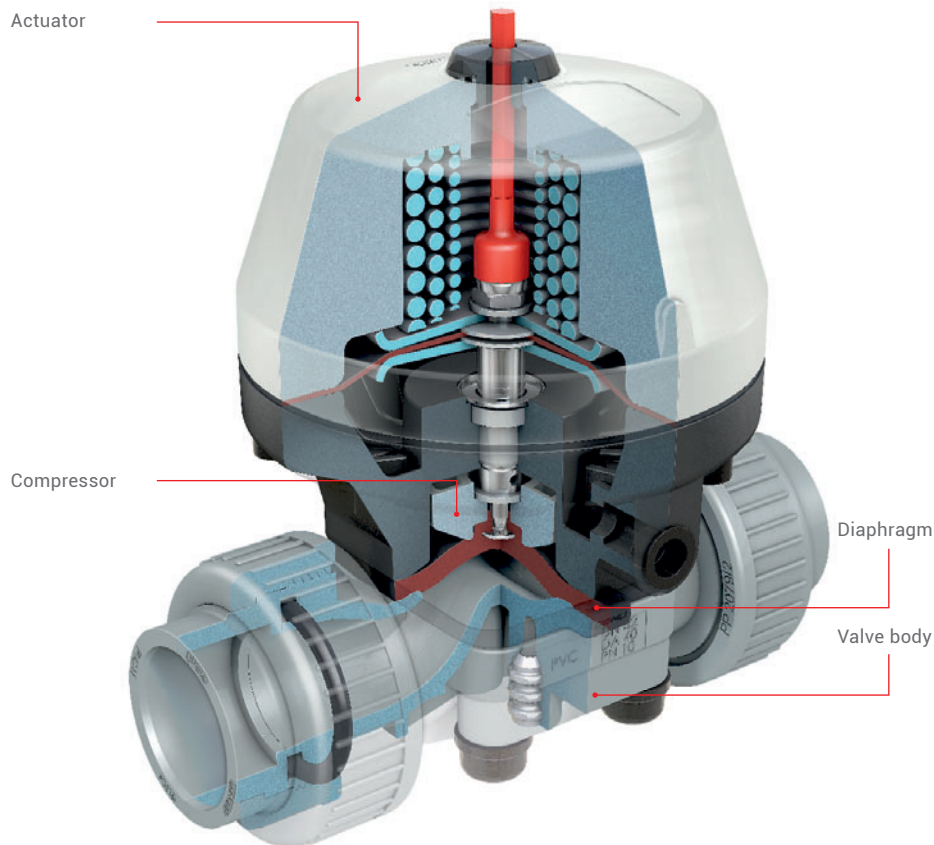

As a recognised diaphragm valve specialist, GEMÜ are familiar with almost all industrial sectors and applications. We are the leading supplier of stainless steel valves for sterile applications in the pharmaceutical industry, biotechnology industry, as well as the foodstuff and beverage industries. As well as this, our valves also stand for reliability and a high standard of quality in the chemical and processing industries. The diaphragm, a central sealing element in the piping system is of major importance. Only the diaphragm and the valve body are in contact with the medium. At the same time, they also guarantee external hermetic sealing of the pipeline.

The system is more than the sum of the individual parts

The outstanding characteristics of the diaphragm valve are the result of the perfect interaction of tuned components. These are the valve body, the shut-off diaphragm, the diaphragm fixing, the compressor as well as the actuator. Our many years of experience and intensive dialogue with plant operators has enabled us to continue optimising the diaphragm valve design and its individual components.

Diaphragm and valve body are inseparable

GEMÜ valve bodies have a raised circular sealing bead on the inside diameter, in contrast to the valve bodies of other manufacturers. This results in a defined external sealing point. This measure reduces the ring-shaped gap between diaphragm and valve body in the external sealing area. This special feature makes GEMÜ diaphragm valves suitable for sterile applications. We also consider this crucial design and functional characteristic, which was developed by GEMÜ over three decades ago, during the development of our diaphragms. Only this ensures that our customers can rely on the valve as a complete unit.

GEMÜ diaphragms have been developed, tested, and approved for applications with GEMÜ valve bodies. GEMÜ do not recommend or guarantee the use of other manufacturers diaphragms with GEMÜ valve bodies due to the unique original GEMÜ design and sealing system. We shall not accept any liability resulting from the use of diaphragms of other manufacturers inside GEMÜ diaphragm valves.

GEMÜ flexible diaphragm fixing

The diaphragm is uniformly fixed in the compressor by means of a threaded pin. The only exception is the smallest diaphragm size (diaphragm size 8), which is pushed in with a rubber pin. The uniform fixing method applies both to soft elastomer and PTFE diaphragms. The largest advantage of fixing by means of a threaded pin, e.g. in comparison to a bayonet fitting, is that the force transfer is distributed onto the large area of the flanks of the screw thread. This prevents damage to the mechanical connection between compressor and diaphragm especially under vacuum operating conditions. The uniform fixing of elastomer and PTFE diaphragms permits subsequent replacement of the diaphragms at any time without having to exchange the actuator because its mounting is different like other manufacturers.

Diaphragms without paint adhesion interfering substances

We supply valves and diaphragms, which are free from substances that prevent paint adhesion (e.g. silicone) for applications in the surface finishing/painting industry. The diaphragms and valves are cleaned accordingly and packed individually in plastic bags. Furthermore, silicone-free lubricants are used during assembly.



Diaphragm size 8

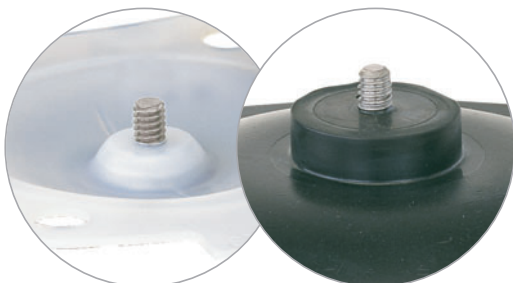

Diaphragm sizes 10 - 100



Packed diaphragms, without paint adhesion interfering substances

GEMÜ diaphragms

Soft elastomer and PTFE

Soft elastomer diaphragms

Soft elastomer diaphragms consist of EPDM rubber mixtures, which are peroxidically cross-linked (vulcanised) with each other. The diaphragms are provided with different technical features according to the mixture used, the duration of the cross-linking process, the vulcanisation temperature as well as the vulcanisation pressure. The following statement applies in principle to soft elastomer materials: the higher the temperature load capability, the lower the service life is in relationship to the mechanical stress. Therefore both the temperature load and the deformability of diaphragms must be optimally adjusted to the application. Different constructional designs are available to achieve this. Soft elastomer diaphragms are characterised by a high insensitivity in the case of mechanically contaminated working media, e.g. cellular lumps, solid matter or catalytic solid matter. Slurries usually do not affect the function of the valve or the seal on the valve weir. Different EPDM rubber mixtures can be selected according to the operating/sterilisation temperatures and the chemical characteristics of the working media.

PTFE diaphragms

The GEMÜ PTFE diaphragms are made of a chemically modified second-generation PTFE (TFM™ PTFE). They provide maximum chemical resistance. Even under steam conditions, PTFE diaphragms wear much more slowly than soft elastomer diaphragms. In the case of highly permeating media the structure of PTFE materials requires appropriately larger bonding thicknesses, stiffening this diaphragm version compared to pure soft elastomer diaphragms. Due to the higher rigidity the service life of the diaphragm may be reduced on high cycle duties depending on the application.



Code 17, diaphragm size 25



Code 5E, diaphragm size 25

GEMÜ 617 / 610 / 613

Diaphragm valves



GEMÜ 617
manually operated

Features

- DN 12 to 20
- Robust plastic bonnet
- Ergonomic, rising handwheel
- Option: lockable handwheel
- Optical position indicator



GEMÜ 610
pneumatically operated

Features

- DN 12 to 20
- Robust plastic piston actuator
- Connection thread for electrical position indicator, travel sensor and positioner
- Optical position indicator
- Connection types: Threaded sockets, solvent cement sockets, flare connection, spigots and union ends
- Valve bodies in PVC-U grey, PP reinforced, PP-H natural and PVDF



GEMÜ 613
motorized

Features

- DN 12 to 15
- Position feedback by means of potential-free limit switches or potentiometer as an option
- Low maintenance motorized actuator with reversible synchronous motor
- Optical position indicator
- Connection types: Threaded sockets, solvent cement sockets, spigots and union ends
- Valve bodies in PVC-U grey, PP reinforced, PVDF

GEMÜ R677 / R690 / R647

Diaphragm valves



GEMÜ R677
manually operated

Features

- DN 15 to 100
- Very compact bonnet design
- Integral optical position indicator
- Smooth surfaces (reduced dirt entrapment)
- Encapsulated threaded inserts
- Lockable handwheel



GEMÜ R690
pneumatically operated

Features

- DN 15 to 100
- Compact and lightweight construction (reduced control air volume)
- Smooth surfaces (reduced dirt entrapment)
- Integral optical position indicator
- Encapsulated threaded inserts
- Actuators bolted from below



GEMÜ R647
pneumatically operated

Features

- DN 15 to 50
- Compact design with good flow capability
- Simple diaphragm replacement
- Good flow characteristics due to flow optimised valve body
- Insensitive to particulate media
- Opened by operating pressure, closed by control pressure
- Diaphragm material NBR or EPDM

GEMÜ R680 / R693

Diaphragm valves



GEMÜ R680
motorized

Features

- DN 15 to 25
- Compact and lightweight construction
- Optional flow direction and installation position
- Insensitive to particulate media
- Integral optical position indicator



GEMÜ R693
motorized

Features

- DN 15 to 50
- Robust plastic actuator housing
- Consistent control system and reliable OPEN/CLOSE function
- Adjustable limit switch for valve stroke limitation
- Option: Electrical position feedback by means of a potentiometer
- Stainless steel distance piece
- Integral optical position indicator
- Manual override

GEMÜ 1041 Compensating/mounting plates

Compensating/mounting plates for GEMÜ plastic diaphragm valves

GEMÜ 1041 000 Z02 - mounting compensating plate, PP (glass fibre reinforced)

Function: Mounting plate for GEMÜ 610 and 617, DN 12 and 15

Order code: 1041 000 Z02

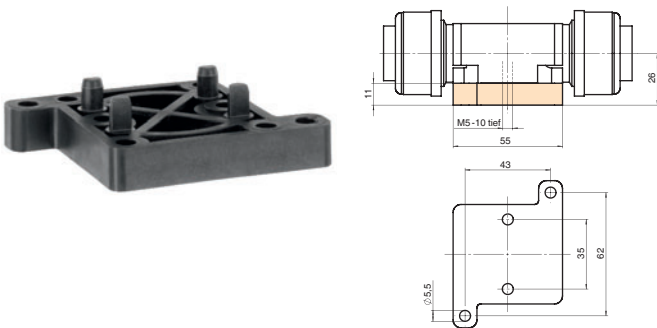

GEMÜ 1041 000 Z05 - mounting compensating plate, PP (glass fibre reinforced)

Function:

- A mounting plate to raise the valve body so unions do not foul mounting surfaces
- Compensating plate for DN 15 - 32 so they align with the pipe centres of the DN 32 - 65 bodies when these are directly mounted without a compensating plate

For valve type: GEMÜ R693, R677, R690, R647

Order code: 1041 000 Z05

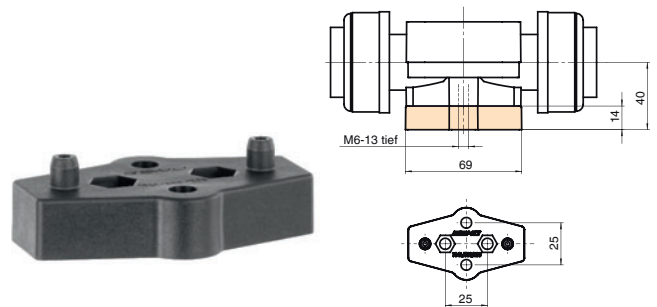

GEMÜ 1041 000 Z03 - mounting compensating plate, PP (glass fibre reinforced)

Function:

- A mounting plate to raise the valve body so unions do not foul mounting surfaces
- Compensating plate for DN 15 - 25 so they align with the geometries of the DN 32 - 50 bodies when these are directly mounted without a mounting plate

Order code: 1041 000 Z03

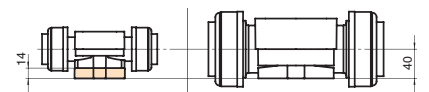
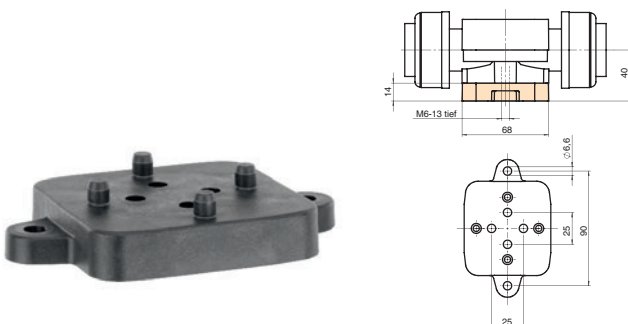

GEMÜ R693	DN 15 to 25	DN 32 to 50
GEMÜ R647	DN 15 to 32	DN 40 to 50
GEMÜ R677, R690	DN 15 to 32	DN 40 to 65

GEMÜ 1041 000 Z06 - mounting compensating plate, PP (glass fibre reinforced)

Function: Compensating plate for DN 15 - 32 so they align with the pipe centres of the DN 32 - 65 bodies (when these are equipped with compensating plate GEMÜ 1041 000 Z07)

For valve type: GEMÜ R693, R677, R690, R647

Order code: 1041 000 Z06

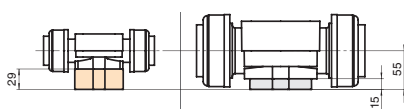
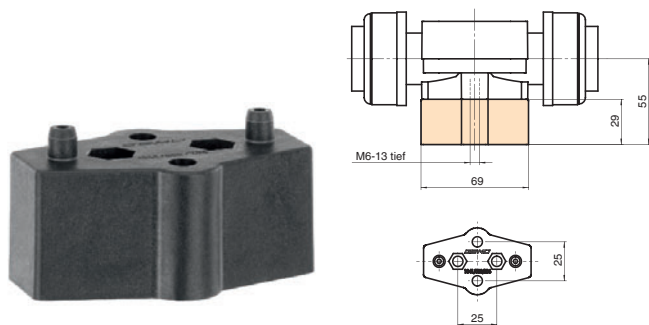

GEMÜ R693	DN 15 to 25	DN 32 to 50
GEMÜ R647	DN 15 to 32	DN 40 to 50
GEMÜ R677, R690	DN 15 to 32	DN 40 to 65

GEMÜ 1041 000 Z07 - mounting compensating plate, PP (glass fibre reinforced)

Function:

- A mounting plate to raise the valve body so unions do not foul mounting surfaces
- Compensating plate for DN 40 - 65 so they align with the pipe centres of the DN 15 - 32 bodies when these are equipped with compensating plate GEMÜ 1041 000 Z06 and compensating plate for GEMÜ R690 (DN 40 - 65) so they align with the pipe centre of GEMÜ R690 (DN 80)

Order code: 1041 000 Z07

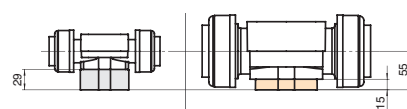
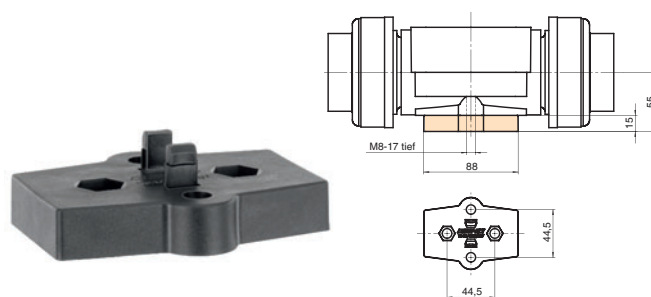

GEMÜ R693	DN 15 to 25	DN 32 to 50
GEMÜ R647	DN 15 to 32	DN 40 to 50
GEMÜ R677, R690	DN 15 to 32	DN 40 to 65

Other accessories



Threaded socket GEMÜ 1031
Plastic PVC-U grey or PP,
DN 15 to 50



Union GEMÜ 1035
Plastic PVC-U grey, PP or PVDF,
DN 10 to 100



Flange GEMÜ 1034
Plastic PVC-U grey
DN 15 to 100

Multi-port valve blocks

Multi-port valves or multi-port valve blocks unite a variety of functions in the smallest of spaces thanks to their individual design, such as:

- Mixing
- Dividing
- Diverting
- Draining
- Feeding

They can also fulfil safety functions, double shut-off (double block and bleed), cross connections and control functions. These individual functions serve very specific purposes in individual situations, such as the taking of samples, the distribution of chemicals, the connection of cleaning media (CIP) and ensuring a minimum flow rate. There are also numerous more complex functions in connection with process automation. Pressure or temperature sensors can be integrated for example. Intelligently designed, multi-port valve blocks can be developed into compact system components with a high degree of functionality.

Advantages

- Individual, customised and flexible design
- Very compact
- Fewer fittings, welds or solvent cemented joints → fewer potential leakage points
- Lower assembly and installation costs
- Low hold-up volume, smaller wetted area
- Operators and diaphragms/seals from the proven GEMÜ modular system
- Produced from a single block of material (standard materials PVC-U, PP, PP natural, PVDF and PEEK); further materials on request
- Standard connections: threaded sockets, solvent cement spigots, butt weld spigots, union ends and flanges



Extendable plastic multi-port valve block



Multi-port valve block with integrated sensor system and filter unit



Multi-port valve block GEMÜ iComLine

GEMÜ 563

Globe valve



GEMÜ 563
motorized

Features

- DN 3 to 15
- Motorized dosing and control valve
- Kv values: 63 - 3300 l/h
- Low maintenance motorized actuator with reversible synchronous motor
- Position feedback by means of potential-free limit switches or potentiometer as an option
- Optical position indicator
- Option with integrated positioner for position control or control of process variables, consistent control system

Plastic diaphragm valves

Plastic diaphragm valves for ultra pure media



GEMÜ CleanStar valves

CleanStar

Ultra pure PFA or PP diaphragm valves
flow optimised valve body

PurePlus

PVDF-HP diaphragm valves

iComLine

Valves with innovative globe diaphragm
valve design, all media wetted parts
made of PTFE



Water treatment with GEMÜ PurePlus valves



Plant in the semiconductor industry with GEMÜ iComLine valves

GEMÜ CleanStar

Ultra pure PFA and PP diaphragm valves

Standard: Optical position indicator and stroke limiter

PFA valve body

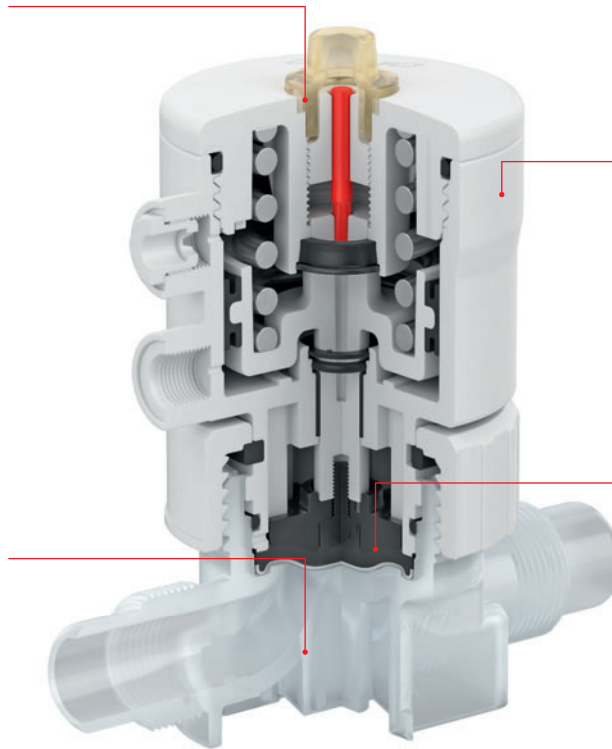

Low maintenance piston actuator

Diaphragm (PTFE/EPDM)



Type	GEMÜ C67 CleanStar	GEMÜ C60 CleanStar	GEMÜ C67, C60 CleanStar SmartLine
Operator	manual	pneumatic	manual / pneumatic
Nominal size	DN 4 to 25 (1/4" to 1 1/4")	DN 4 to 25 (1/4" to 1 1/4")	DN 10 to 32 (1/2" to 1 1/4")
Connection type	Flare connection, butt weld spigot, SpaceSaver, Tube Stub, SpaceSaver Pillar, PrimeLock	Flare connection, butt weld spigot, SpaceSaver, Tube Stub, SpaceSaver Pillar, PrimeLock	Flare connection, butt weld spigots
Valve body material	PFA, PVDF	PFA, PVDF	PP-H grey, PP-R natural
Media temperature *	-10 to 150 °C	-10 to 150 °C	-10 to 90 °C
Operating pressure *	0 to 6 bar	0 to 6 bar	0 to 6 bar
Diaphragm material	PTFE/EPDM	PTFE/EPDM	PTFE/EPDM

* depending on version and/or operating parameters

GEMÜ C60, C67 CleanStar



GEMÜ C67 CleanStar
manually operated

Features

- Ergonomic handwheel
- Metal-free
- External operator parts made of PVDF
- Standard seal adjuster and position indicator
- Union nut optionally made of ECTFE
- HighFlow version available



GEMÜ C60 CleanStar
pneumatically operated

Features

- Low maintenance piston actuator
- Control functions: NC, NO, DA
- External actuator parts made of PVDF
- Standard stroke limiter and position indicator
- Union nut optionally made of ECTFE
- Electrical position indicator and process controller available

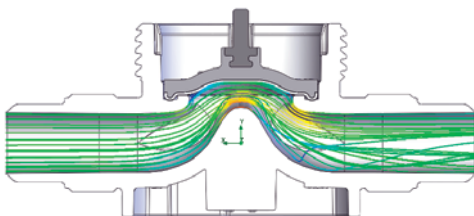

GEMÜ C60 CleanStar
High-Flow valve body

Features

- Significantly improved flow rate due to flow-efficient seat contour
- Low pressure loss resulting in cost savings
- Low-impact media handling due to gentle flow lines
- Longlife seat contour
- Up to 100 % Kv value increase (depending on nominal size/connection)
- Same outer dimensions and connection to actuator as standard body



GEMÜ C60 CleanStar SmartLine
pneumatically operated

Features

- Design with PP valve bodies
- Low cost CleanStar version
- For areas of application with lower purity requirements
- PTFE diaphragm
- Metal-free
(GEMÜ C67 and GEMÜ C60 control function DA)
- Choice of valve bodies made of PP-R natural or PP-H grey
- Bodies with flare connections and DIN butt weld spigots



GEMÜ C67 CleanStar
3-way valve with dual
operator concept

Features

- Ergonomic handwheel
- Metal-free
- External operator parts made of PVDF
- Standard seal adjuster and position indicator
- Union nut optionally made of ECTFE
- HighFlow version available



GEMÜ C60 CleanStar
T valve

Features

- T body design minimizes deadleg
- Saves using a T fitting
- Requires less space
- Coupling by space saver connection requires less space
- Ideal for manifolds in valve boxes
- Can be used as a sampling valve

GEMÜ PurePlus

Ultra pure PVDF/PP diaphragm valves



Type	GEMÜ 677 HP	GEMÜ 690 HP
Operator	manual	pneumatic
Nominal size	DN 15 to 100	DN 15 to 100
Connection type	Butt weld spigots	Butt weld spigots
Valve body material	PFA inliner / PVDF outliner reinforced, PVDF	PP-H inliner / PP outliner reinforced, PVDF
Media temperature *	-20 to 120 °C	-10 to 80 °C
Operating pressure *	0 to 10 bar	0 to 10 bar
Diaphragm material	PTFE/EPDM	PTFE/EPDM

* depending on version and/or operating parameters

GEMÜ 677 HP, 690 HP PurePlus



GEMÜ 677 HP
manually operated

Features

- DN 15 to 100
- PTFE/EPDM diaphragm
- 2/2-way or T valve body
- Butt weld spigots
- Optimised pressure/temperature rating



GEMÜ 690 HP
pneumatically operated

Features

- DN 15 to 100
- PTFE/EPDM diaphragm
- 2/2-way or T valve body
- Butt weld spigots
- Valve body material PP-H or PVDF

GEMÜ iComLine

Ultra pure PTFE diaphragm globe valves

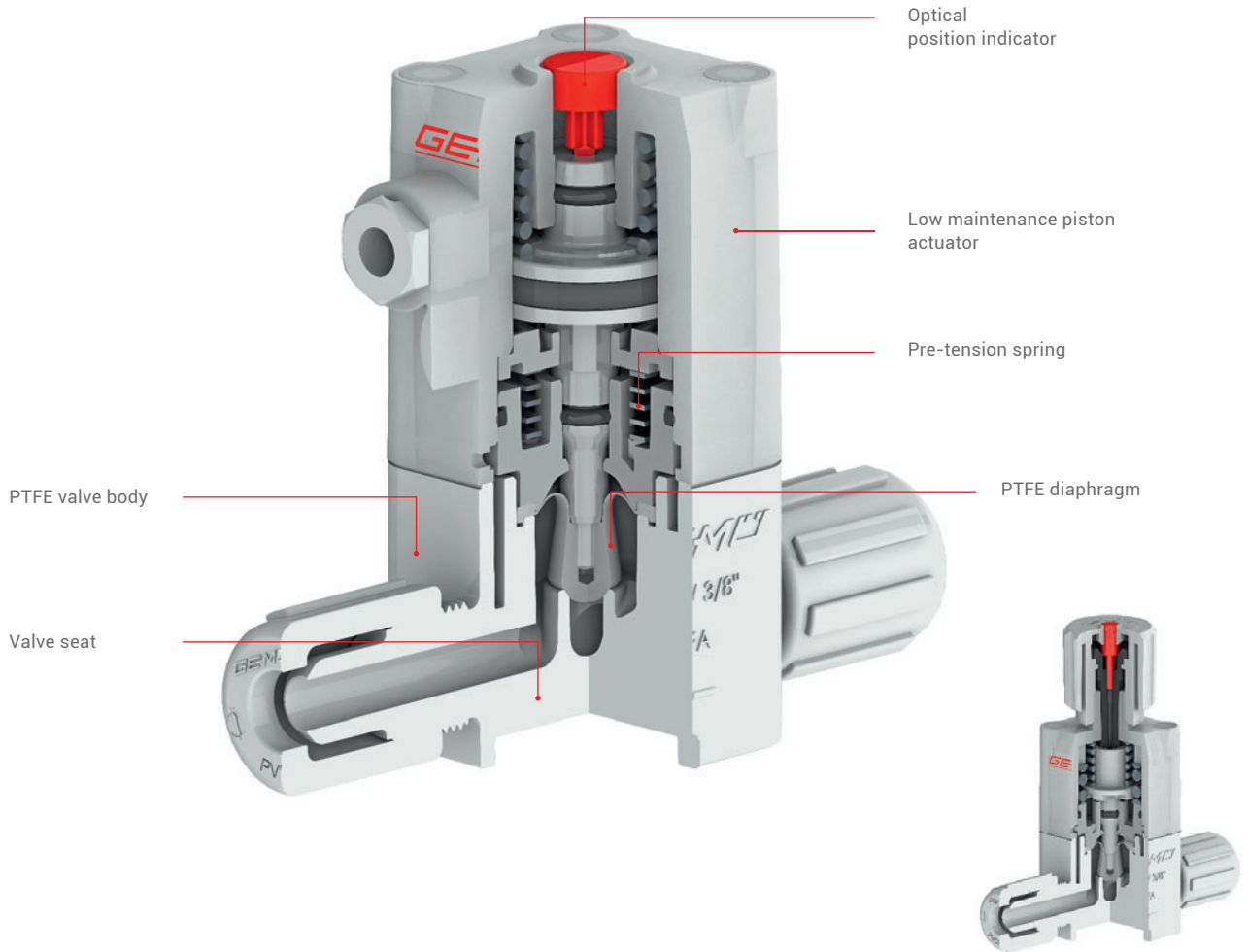

Type	GEMÜ C50 iComLine	GEMÜ C51 iComLine	GEMÜ C57 iComLine
Operator	pneumatic	manual	manual
Nominal size	DN 4 to 25 (¼" to 1¼")	DN 4 to 25 (¼" to 1¼")	DN 4 to 25 (¼" to 1¼")
Connection type *	Flare, Pillar® and PrimeLock® connection	Flare, Pillar® and PrimeLock® connection	Flare, Pillar® and PrimeLock® connection
Valve body material *	PTFE, PFA	PTFE, PFA	PTFE, PFA
Media temperature *	-5 to 180 °C	-5 to 180 °C	-5 to 180 °C
Operating pressure	0 to 6 bar	0 to 6 bar	0 to 8 bar
Diaphragm material	PTFE	PTFE	PTFE

* depending on version and/or operating parameters

GEMÜ C50, C51, C57 iComLine



GEMÜ C50 iComLine
pneumatically operated

Features

- Low maintenance piston actuator
- Control functions: NC and NO
- All external actuator parts made of PVDF
- All media wetted parts made of PTFE
- Standard optical position indicator
- Stroke limiter available
- Integral mounting lugs
- Electrical position indicators and positioners can be fitted



GEMÜ C51 iComLine
manually operated (quarter turn)

Features

- Quarter turn manual valve
- Toggle for operation
- Handwheel for setting a defined flow
- All external operator parts made of PVDF
- All media wetted parts made of PTFE
- Integral mounting lugs



GEMÜ C57 iComLine
manually operated

Features

- Ergonomic handwheel
- All external operator parts made of PVDF
- All media wetted parts made of PTFE
- Optical position indicator
- Integral mounting lugs

Butterfly valves

- DN 15 to 300
- GEMÜ RSK check valves
- Operators: manual, pneumatic and motorized

Extensive range of accessories:

- Pilot valves
- Electrical position indicators
- Optical position indicators
- Electro-pneumatic positioners and process controllers



Type	GEMÜ 417	GEMÜ 410	GEMÜ 423	GEMÜ D457	GEMÜ D451	GEMÜ D458
Operator	manual	pneumatic	motorized	manual	pneumatic	motorized
Nominal size	DN 15 to 100	DN 15 to 100	DN 15 to 100	DN 50 to 300	DN 50 to 300	DN 50 to 300
Connection type	Union ends with DIN insert (socket), union ends with inch insert (socket)	Union ends with DIN insert (socket), union ends with inch insert (socket)	Union ends with DIN insert (socket), union ends with inch insert (socket)	EN 1092 PN 10 / ANSI B16.5, Class 150 / JIS 10K	EN 1092 PN 10 / ANSI B16.5, Class 150 / JIS 10K	EN 1092 PN 10 / ANSI B16.5, Class 150 / JIS 10K
Valve body material	PVC-U grey	PVC-U grey	PVC-U grey	PP (GF)	PP (GF)	PP (GF)
Media temperature *	-10 to 60 °C	-10 to 60 °C	-10 to 60 °C	0 to 90 °C	0 to 90 °C	0 to 90 °C
Operating pressure *	0 to 6 bar	0 to 6 bar	0 to 6 bar	0 to 10 bar	0 to 10 bar	0 to 10 bar
Disc material	PVDF, PP	PVDF, PP	PVDF, PP	PVC-U, PVC-C, PP-H	PVC-U, PVC-C, PP-H	PVC-U, PVC-C, PP-H
Seal material	FPM, EPDM	FPM, EPDM	FPM, EPDM	FPM, EPDM	FPM, EPDM	FPM, EPDM
Voltage	-	-	24 VDC, 120 VAC, 230 VAC 50/60Hz	-	-	24 VDC, 120 VAC, 230 VAC 50/60Hz

* dependent on nominal size and design



GEMÜ D451 with GEMÜ 4221 combi switchbox



GEMÜ D451 with GEMÜ 1436 cPos positioner



GEMÜ DR/SC pneumatic quarter turn actuator with GEMÜ 1435 ePos positioner

GEMÜ 417, 410, 423



GEMÜ 417
manually operated

Features

- DN 15 to 100
- Integrated locking device
- Ergonomic operator
- One-piece butterfly disc and shaft



GEMÜ 410
pneumatically operated

Features

- DN 15 to 100
- Low maintenance, corrosion resistant pneumatic actuator
- Connection thread for electrical position indicator and accessories
- Control air connector
- One-piece butterfly disc and shaft
- Optional electrical position indication via two potential-free limit switches
- Optional stroke limiter



GEMÜ 423
motorized

Features

- DN 15 to 100
- Powerful, reversible DC motor
- Low maintenance motorized actuator
- Option with electrical position feedback by potential-free limit switches
- Integral position indicator
- Option with emergency power supply
- Integrated manual override
- One-piece butterfly disc and shaft

GEMÜ D457, D451, D458



GEMÜ D457
manually operated

Features

- DN 50 to 300
- Lockable hand lever
- Pneumatic or motorized actuators can be retrofitted
- Low weight
- Wafer body for flange connection acc. to EN 1092, ANSI, JIS
- Variety of materials: Disc material made of PVC-U, PVC-C, PP-H



GEMÜ D451
pneumatically operated

Features

- DN 50 to 300
- Pneumatic plastic piston actuator
- Connection thread for electrical position indicator, positioner and accessories
- Low weight



GEMÜ D458
motorized

Features

- DN 50 to 300
- Low maintenance motorized actuator
- Optical position indicator
- Option with integrated positioner
- Integrated manual override
- Low weight

Ball valves

- Good flow capability
- All media wetted parts and actuator housing are made of plastic
- Suitable for clean, non-particulate media (inert or corrosive and gaseous or liquid), which have no negative impact on the physical and chemical properties of the body and seal material



Type	GEMÜ 717	GEMÜ S717	GEMÜ 710	GEMÜ 723
Operator	manual	manual	pneumatic	motorized
Nominal size	DN 10 to 100	DN 10 to 100	DN 10 to 100	DN 10 to 100
Body configuration	Straight through: (2/2-way): DN 10 to 100 Multi-port: (3/2-way): DN 10 to 50	Straight through: (2/2-way)	Straight through: (2/2-way): DN 10 to 100 Multi-port: (3/2-way): DN 10 to 50	Straight through: (2/2-way): DN 10 to 100 Multi-port: (3/2-way): DN 10 to 50
Connection type	Solvent cement/welded sockets DIN and BS, flanges DIN and ANSI, union ends with insert PE, PP, PVDF in DIN for IR/butt welding, RP threaded sockets	Solvent cement/welded sockets DIN, union ends with inch insert (socket), RP threaded sockets	Solvent cement/welded sockets DIN and BS, flanges DIN and ANSI, union ends with insert PE, PP, PVDF in DIN for IR/butt welding, RP threaded sockets	Solvent cement/welded sockets DIN and BS, flanges DIN and ANSI, union ends with insert PE, PP, PVDF in DIN for IR/butt welding, RP threaded sockets
Valve body material	PVC-U, PVC-C, ABS, PP-H, PVDF	PVC-U, PP-H	PVC-U, PVC-C, ABS, PP-H, PVDF	PVC-U, PVC-C, ABS, PP-H, PVDF
Media temperature *	-40 to 120 °C	0 to 60 °C	-40 to 120 °C	-40 to 120 °C
Operating pressure **	0 to 16 bar	0 to 16 bar	0 to 10 bar	0 to 10 bar
PN	PVC-U, PVC-C and PVDF: PN16 ABS, PP, PVC-C (from DN 65): PN10	PVC-U (DN 10 to 50): PN 16 PVC-U (DN 65 to 100), PP-H (DN 10 to 100): PN 10	PVC-U, PVC-C and PVDF: PN16 ABS, PP, PVC-C (from DN 65): PN10	PVC-U, PVC-C and PVDF: PN16 ABS, PP, PVC-C (from DN 65): PN10
Voltage	-	-	-	12 V - 24 V DC 12 V - 24 V AC 100 V - 250 AC

* dependent on nominal size and operating pressure; ** dependent on nominal size and operating temperature

GEMÜ 717, S717, 710, 723



GEMÜ 717
manually operated



GEMÜ S717
manually operated



GEMÜ 710
pneumatically operated



GEMÜ 723
motorized



Features

- DN 10 to 100
- Ergonomic hand lever
- High quality design for the chemical industry
- Robust 2/2-way and 3/2-way body
- Locking mechanism to secure union nuts

Features

- DN 10 to 100
- Robust 2/2-way body
- Ergonomic hand lever with non-slip rubber coating
- Various connections available

Features

- DN 10 to 100
- Pneumatic plastic piston actuator
- Connection thread for accessories
- Control air connector (DA), vent hole (NC)
- High quality design for the chemical industry
- Robust 2/2-way and 3/2-way body
- Locking mechanism to secure union nuts

Features

- DN 10 to 100
- Low maintenance motorized actuator
- Powerful, reversible DC motor
- Option with electrical position feedback by potential-free limit switches
- Option with emergency power supply
- Integrated manual override and position indicator
- High quality design for the chemical industry
- Robust 2/2-way and 3/2-way body
- Locking mechanism to secure union nuts

Angle seat valves

GEMÜ N507 angle seat globe valve with handwheel

The GEMÜ N507 manually operated valve consists entirely of plastic. All components (except for sealing elements) are made of PVC-U.

GEMÜ N560 check valve

The GEMÜ N560 check valve comprises an angle seat globe valve body made of plastic (either PVC-U or PP-H). The sealing elements are manufactured from EPDM and FPM.

GEMÜ N570 strainer

The GEMÜ N570 strainer has a plastic body (PVC-U or PP-H). The sealing elements are manufactured from EPDM or FPM. The integrated filter insert filters suspended matters in the medium.



Type	GEMÜ N507	GEMÜ N560	GEMÜ N570
Operator	manual	Check valve	Strainer
Nominal size	DN 10 to 100	PVC-U: DN 10 to 100 PP-H: DN 15 to 80	PVC-U: DN 10 to 100 PP-H: DN 15 to 100
Body configuration	2/2-way straight through body	2/2-way straight through body	2/2-way straight through body
Connection type	Spigots DIN, threaded sockets DIN ISO 228, solvent cement/welded sockets DIN, flanges EN 1092 / PN10 / form B	Spigots DIN, threaded sockets DIN ISO 228, solvent cement/welded sockets DIN, flanges EN 1092 / PN10 / form B, flanges ANSI Class 150 FF	Spigots DIN, threaded sockets DIN ISO 228, solvent cement/welded sockets DIN, flanges EN 1092 / PN10 / form B, flanges ANSI Class 150 FF
Valve body material	PVC-U grey	PVC-U, grey; PP-H, grey	PVC-U grey, PVC-U transparent, PP-H grey
Media temperature *	10 to 60 °C	PVC-U: 10 to 60 °C, PP-H: 5 to 80 °C	PVC-U: 10 to 60 °C, PP-H: 5 to 80 °C
Operating pressure **	0 to 16 bar	PVC-U: 0 to 16 bar PP-H: 0 to 10 bar	PVC-U: 0 to 16 bar PP-H: 0 to 10 bar
Seal material	FPM, EPDM	FPM, EPDM	FPM, EPDM

* dependent on nominal size and operating pressure; ** dependent on nominal size and operating temperature

GEMÜ N507, N560, N570



GEMÜ N507
manually operated

Features

- DN 10 to 100
- Not suitable for gases as not soft seated
- Made of corrosion resistant materials
- Good flow capability
- For isolation and control of liquids in pipings



GEMÜ N560
Check valve

Features

- DN 10 to 100
- Made of corrosion resistant materials
- Good flow capability
- To protect the pipelines against emptying of liquids



GEMÜ N570
Strainer

Features

- DN 10 to 100
- Made of corrosion resistant materials
- Filters available in various materials and mesh sizes
- Strainer for holding back impurities in flowing liquids

Positioners and process controllers

Positioners and process controllers - Overview

GEMÜ pneumatic actuators can usually be paired with our electro-pneumatic positioners and process controllers.

In addition to the process parameters and the control system for which a positioner must be suitable, other technical functions and properties also play an important part in the selection of the right positioner.



Function / Features		GEMÜ 1434 µPos	GEMÜ 1435 ePos	GEMÜ 1436 cPos	GEMÜ 1436 cPos eco
Controller type	Positioner	•	•	•	•
	Process controller			•	
Operation	Local display / keypad		•	•	
	Status display	•	•	•	•
	Web browser user			•	
	Fieldbus option (Profibus DP, Device Net)			•	
Housing	Plastic	•		•	•
	Aluminium		•		
Functions	Automatic initialisation (speed ^{AP})	•	•	•	•
	Alarm / error outputs		•	•	
	Min/max positions adjustable		•	•	
Mounting	Direct mounting to linear actuators	•	•	•	•
	Remote mounting to linear actuators	•	•	•	•
	Direct mounting to quarter turn actuators		•	•	•
	Remote mounting to quarter turn actuators		•	•	•
Control function of valve actuator	Control function 1, normally closed (NC)	•	•	•	•
	Control function 2, normally open (NO)	•	•	•	•
	Control function 3, double acting (DA)		•	•	
Air output		15 NI/min.	50 NI/min. 90 NI/min.	150 NI/min. 200 NI/min. 300 NI/min.	150 NI/min. 200 NI/min.

Combi switchboxes and electrical position indicators

Combi switchboxes and electrical position indicators are integrated components of an intelligent process automation system.

Intelligent process automation follows a comprehensive approach which comprises the upper control levels as well as also innovative components and valves at the field level. GEMÜ has been offering valves and precisely tuned valve instrumentation, controllers, sensor systems, valve actuators, and system solutions for process automation for some years now: It could be said that you take care of your process, we take care of the component interfaces. Moreover, we believe that the most reliable and safest monitoring of valves always take place directly at the valve itself.

Linear type valves and quarter turn valves are frequently used with electrical position indicators. GEMÜ provides the most varied designs to suit any automation concept. The product range not only comprises simple switches but also intelligent designs equipped with timesaving automated initialisation. Explosion-proof versions are also available. Advanced combi switchboxes may be used in fieldbus networks such as AS-interface and DeviceNet.



GEMÜ 1235
with GEMÜ R690 diaphragm valve



GEMÜ 4221
with GEMÜ D451 plastic butterfly valve



GEMÜ 1234
with GEMÜ 610 diaphragm valve

Combi switchboxes and electrical position indicators for pneumatically operated linear valves

Our devices detect the valve stroke in any installation position without play and are tension-free. The sensor base of the GEMÜ 1234, 1235 and 4242 series is positively connected to the valve spindle by means of a preloaded spring so that possible tangential forces of the valve actuator do not negatively affect the position indicator. The position indicators can be quickly and easily assembled and are safe and uncomplicated to handle.

They can be adapted to pneumatic actuators of GEMÜ globe and diaphragm valves.



Device type	Combi switchbox										
	4242	1215	1230	1231	1232	1201	1211	1214	1234	1235/ 1236	1242
Valve stroke (in mm)	2 - 75		2 - 20	2 - 20	2 - 20	2 - 70	2 - 70	2 - 70	1 - 10	2 - 30 4 - 50 5 - 75	2 - 46
Electrical connection	M12	¹⁾	¹⁾	²⁾	¹⁾	²⁾	²⁾	¹⁾	M12	M12	M12
Programmable	•								•	•	•
With integrated pilot valve	•										
Ex design		• ³⁾		•			•				
NEC 500 version	•										•
Fieldbus interface	•								•		•
Mechanically adjustable switches			•	•	•	•	•	•			
Mechanically adjustable (microswitches)			•			•					
UL version	•		•								•
SIL version										•	
Optical position indicator (LEDs)	•		•		•			•	•	•	•
Optical position indicator (mechanical)	• ⁴⁾	•									
Feedback (OPEN and CLOSED)	•		•	•	•	•	•	•	•	•	•
Feedback (OPEN)		•									

¹⁾ cable gland, M12 (optional)

²⁾ cable gland

³⁾ not with optional M12 plug

⁴⁾ for size 2 only

Electrical position indicators

Electrical position indicators for pneumatically operated quarter turn valves

Various electrical position indicators are available for ball valves and butterfly valves. These devices detect the valve position in any installation position without play and are tension-free. The position indicators can be quickly and easily assembled and are safe and uncomplicated to handle.

The special design of the GEMÜ 9415 quarter turn actuator enables its combination with electrical position indicators for linear actuators.

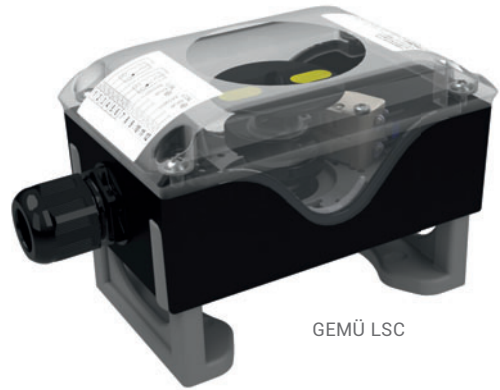

GEMÜ LSC



GEMÜ LSF



Device type	4221* (end-of-series article)	LSF	LSC	1226	1225
Travel range	0 - 90°	0° / 90°	0 - 90°	0° / 90°	0 - 90°
Connection	M12 x 1 5-pin	M12 x 1 4-pin	M20 x 1.5	PG 13.5	PG 13.5
Programmable	•				
With integrated pilot valve	•				
Ex design		•	•		
IEC version			•		
Fieldbus interface	•		•		
Mechanically adjustable switches			•		
UL version			•		•
SIL version			•		
Optical position indicator (mechanical)		•	•	•	•
Feedback (OPEN and CLOSED)	•	•	•	•	•

* Combi switchbox

Pilot valves and valve manifolds

GEMÜ provides a wide range of pilot valves and valve manifolds. The range includes pilot valves for direct mounting to pneumatic valve actuators as well as single valves, valve batteries and complete valve manifolds for

assembly in a control cabinet. In addition to the standard connection methods, pilot valves are also available for fieldbus connections (AS-interface, LON, Profibus, etc.).

GEMÜ 0322, 0324, 0326

3/2-way valves
in plastic
Nominal size: DN 2
Air output approx. 70 l/min



GEMÜ 8505

4/2-way piston valve
with aluminium body
Nominal size: DN 4 / DN 7
Air output approx. 700 / 1,400 l/min



GEMÜ 8357

3/2-way piston valve
with aluminium body
Nominal size: DN 6
Air output approx. 1,200 l/min



GEMÜ 8506

3/2 and 5/2-way piston valve with
aluminium body
Nominal size: DN 6
Air output approx. 1,200 l/min



GEMÜ 8458

5/2-way piston valve
with aluminium body
Nominal size: DN 6
Air output approx. 1,200 l/min



	GEMÜ 0322, 0324	GEMÜ 8357	GEMÜ 8458	GEMÜ 8505	GEMÜ 8506
3/2-way valve, plastic body	•				•
3/2-way valve, aluminium body		•			
4/2-way valve, aluminium body			•		
5/2-way valve, aluminium body				•	•
Nominal size	DN 2	DN 6	DN 6	DN 4 / DN 7	DN 6
Air output in l/min	70	1.200	1.200	700 / 1.400	1.200
Single mounting	•	•	•	•	•
Direct mounting to pneumatic actuator	•	•	•	•	•
Battery mounting	•				
Valve manifold					
Manual operation	•	•	•	•	•
Explosion-proof rating	•				

Solenoid valves

The GEMÜ solenoid valves are suitable for inert and corrosive liquid and gaseous media. They are corrosion-resistant and therefore particularly suitable for:

- Water treatment plant, washing and cleaning installations
- Plant for food and foodstuff industries, the chemical industry and electroplating
- Equipment for the photographic industry, laboratory, analytical and medical apparatus



Type	GEMÜ 52	GEMÜ 102	GEMÜ 202	GEMÜ 205	GEMÜ 225
Operator	directly controlled	directly controlled	directly controlled	directly controlled	Servo assisted
Nominal size	DN 2 to 6	DN 6 to 10	DN 10 to 15	DN 10 to 50	DN 15 to 50
Connection type	Threaded sockets DIN ISO 228, solvent cement sockets - DIN	Threaded sockets DIN ISO 228, solvent cement sockets - DIN	Threaded sockets DIN ISO 228, solvent cement sockets - DIN	Spigots DIN, threaded sockets DIN ISO 228, threaded sockets NPT, solvent cement sockets DIN, solvent cement spigots inch, union ends with DIN insert (socket)	Spigots DIN, solvent cement spigots inch, union ends with DIN insert (socket)
Valve body material	PVC-U grey, PVDF	PVC-U grey, PVDF	PVC-U grey, PVDF	PVC-U grey, PVDF	PVC-U grey, PVDF
Media temperature *	-20 to 100 °C	-20 to 100 °C	-20 to 100 °C	-20 to 60 °C	-20 to 60 °C
Operating pressure *	0 to 6 bar	0 to 4 bar	0 to 2 bar	0 to 6 bar	0 to 6 bar
Seal material	FPM, PTFE, EPDM	FPM, PTFE, EPDM	FPM, PTFE, EPDM	FPM, PTFE, EPDM	FPM, EPDM
Voltage	12 VDC, 24, 120, 230 VDC or VAC, 50/60Hz	12, 24, 120, 230 VDC or VAC, 50/60Hz	12, 24, 120, 230 VDC or VAC, 50/60Hz	24 VDC, 24, 120, 230 VAC 50/60Hz	24 VDC, 24, 120, 230 VAC 50/60Hz

* dependent on nominal size and design

GEMÜ 52, 102, 202



GEMÜ 52
directly controlled
DN 2 to 6



GEMÜ 102
directly controlled
DN 6 to 10



GEMÜ 202
directly controlled
DN 10 to 15

Features

- 2/2-way solenoid valves
- Completely plastic encapsulated DC coil
- The solenoid can be replaced without removing the valve body from the pipeline
- Connector plug to DIN EN 175301-803 form A. The connector plug has a rectifier for use with an AC supply
- The solenoid can be replaced without removing the valve body from the pipeline
- Hermetic separation between medium and actuator by PTFE bellows
- Good cleanability (the valves can be dismantled without tools by unscrewing the union nut)
- ROHS compliant



GEMÜ 205, 225



GEMÜ 205
directly controlled

Features

- DN 10 to 50
- High performance DC coil
- Connector plug to DIN EN 175301-803 form A.
- The connector plug has a rectifier for use with an AC supply
- Optical position indicator
- Manual override
- Hermetic separation between medium and actuator



GEMÜ 225
servo controlled

Features

- DN 15 to 50
- High performance DC coil
- Connector plug to DIN EN 175301-803 form A.
- The connector plug has a rectifier for use with an AC supply
- Piston mechanism, designed as servo control, assists the coil
- Optical position indicator
- Manual override
- Hermetic separation between medium and actuator

GEMÜ pressure control valves

Pressure retaining valves GEMÜ N086, N186 and N786

The GEMÜ N086 and N186 pressure retaining valves are used to provide a constant back pressure in process plant. They can also be used as pressure relief valves to reduce pressure peaks.

Due to their minimal deadleg design, types N086 and N186 are particularly well suited to ultra pure water applications. The product range has been expanded to include the pressure retaining valve GEMÜ N786.

Pressure relief valves GEMÜ N085 and N185

Plant and piping systems are protected against gauge pressure and pressure peaks using pressure relief valves from the GEMÜ N085 and N185 series.

A third pipe spigot facilitates installation in the main pipe through which any overpressure is relieved. Due to the minimal deadleg and flow-efficient design of the valve body, there is only a minimal pressure loss through the valve.

Pressure reducers GEMÜ N082, N182 and N782

GEMÜ pressure reducers are used to reduce the pressure to a specified value, which can be conveniently set using a set screw.

The inlet pressure is reduced to the required outlet pressure utilizing the pressure differential.



Type	GEMÜ N086, N186, N786	GEMÜ N082, N182, N782	GEMÜ N085, N185
Nominal size	DN 10 to 100 *	DN 10 to 100 *	DN 10 to 100 *
Connection type	Spigots, flanges, union ends with insert	Spigots, flanges, union ends with insert	Spigots, flanges, union ends with insert
Valve body material	PVC-U, PP, PVDF	PVC-U, PP, PVDF	PVC-U, PP, PVDF
Media temperature *	-20 to 100 °C	-20 to 100 °C	-20 to 100 °C
Setting range *	0.5 to 10 bar	0.5 to 9 bar	0.5 to 10 bar
Seal material *	EPDM, PTFE	EPDM, PTFE, FPM	EPDM, PTFE

* depending on version and/or operating parameters

GEMÜ N186, N782, N185



GEMÜ N186
Pressure retaining valve

Features

- Adjustment of working pressure via set screw
- Actuator separated from the medium by the actuator membrane
- Can be installed regardless of position
- Low maintenance
- No auxiliary power required for operating the actuator



GEMÜ N782
Pressure reducer

Features

- Adjustment mechanism hermetically separated from the medium
- No auxiliary power required for operating the actuator
- Can be installed irrespective of location
- Low maintenance
- No auxiliary power required for operating the actuator



GEMÜ N185
Pressure relief valve

Features

- Adjustment of working pressure via set screw
- Actuator separated from the medium by the actuator membrane
- Can be installed regardless of position
- Low maintenance
- No auxiliary power required for operating the actuator

Flowmeters

GEMÜ offers flowmeters operating according to the most varied physical measurement principles.

- Variable area flowmeter
- Flow transmitter
- Magnetically inductive flowmeter
- Ultrasonic flowmeter

All these types have their particular features and advantages and are therefore suitable for the most varied applications. The selection of the right measurement principle and its particular design depends on the working medium, the type of measurement required and the conditions prevailing in the plant or machine. The following factors must be considered in detail:

Medium:

- Temperature
- Conductivity
- Density
- Pressure
- Corrosiveness
- Abrasivity
- Viscosity
- Homogeneity
- Aggregate state

Pipeline:

- Quantity / nominal size
- Inlet and outlet distances
- Flow
- Disturbances
- Pressure loss

Measurement:

- Measuring range / dynamics
- Mass or volume
- Accuracy



Flowmeter in an industrial application



UHP water treatment in the semiconductor industry

Flowmeters

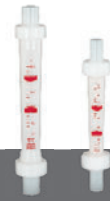

Type	GEMÜ 800	GEMÜ 850	GEMÜ 840	GEMÜ 800 HP	GEMÜ 850 HP
Measuring range liquids ¹	0.5 - 33.000 l/h	0.1 - 1600 l/h	2.5 - 50 m ³ /h	200 - 7000 l/h	20 - 1000 L/h
Measuring range gas/air ¹	0.2 - 450 Nm ³ /h	0.02 - 37.5 Nm ³ /h	-	-	-
Nominal size	DN 20 to 65	DN 10 to 25	DN 20 to 65	DN 15 to 50	DN 15 to 25
Operating temperature ²	-20 to 120 °C	-20 to 120 °C	-20 to 120 °C	-20 to 120 °C	-20 to 120 °C
Operating pressure ²	Max. 10/15 bar	Max. 10/15 bar	Max. 10/15 bar	Max. 10 bar	Max. 10 bar
Metering tube material	PA, Polysulphone (PSU), PVC, PVDF	PA, Polysulphone (PSU), PVC, PVDF	Main flow: PVC, PP Part flow: Polysulphone	PVDF	PVDF
Float material	PP, PVC, PVDF, stainless steel	PP, PVC, PVDF, stainless steel	PP, PVC	PVDF	PVDF
Union/ connection	PP, PVC, PVDF, stainless steel, malleable iron	PP, PVC, PVDF, stainless steel, malleable iron	PVC, PP, stainless steel	PVDF	PVDF

¹ dependent on medium, ² dependent on the materials and the pressure-temperature curve of the materials



Water treatment plant



PVDF



PA 6-3-T



PSU

Variable area flowmeter

GEMÜ 800, 840, 850

Technical specifications:

- Working medium:** Liquids and gas/air
- Measuring range:** 0.1 to 33,000 l/h for liquids
0.02 to 450 Nm³/h for air
- Accuracy:** $\pm 1\%$ of end value and $\pm 3\%$ of measured value
- Operating pressure:** max. 15 bar, dependent on the design
- Media temperature:** -20 to 100 °C
(depending on metering tube material)
- Available materials:** Metering tubes in PSU, Trogamid, PVDF, PVC
- Nominal sizes:** DN 15 to 65
- Automation capability:** Mounting of electrical limit switches or instrument sensors with reed contacts possible
- Particulars:** Over 13,000 special scales available, further scales on request.
GEMÜ 840 operates according to the part flow principle



GEMÜ 800/850



GEMÜ 840

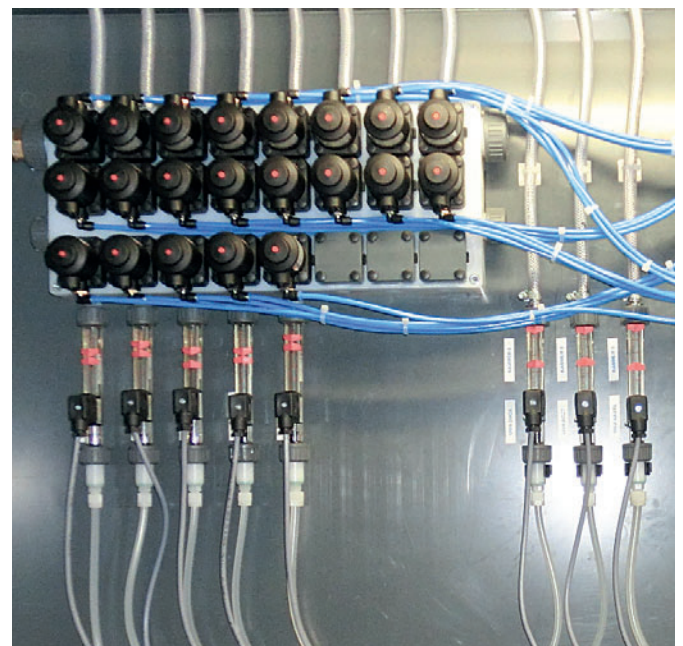
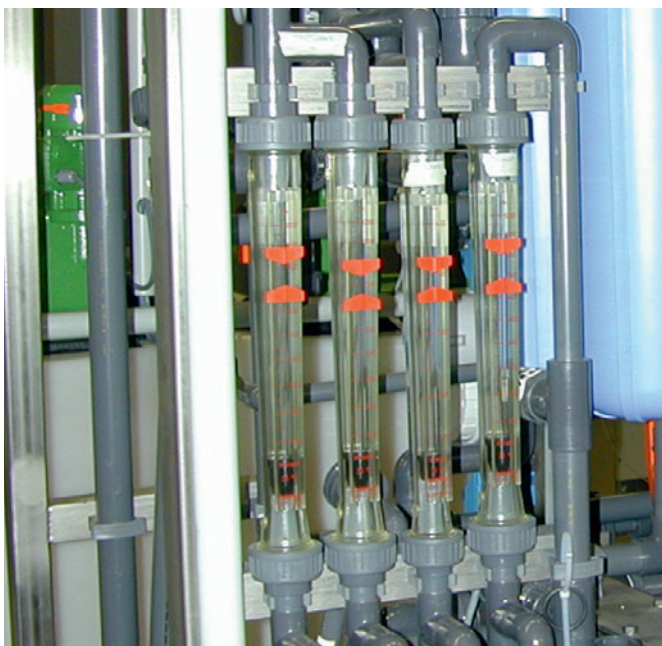

Flowmeters

Limit switches

GEMÜ 1250 - 1257

Features

- Change-over contact GEMÜ 1250
- Limit switch max. contact GEMÜ 1251, 1256
- Limit switch min. contact GEMÜ 1252, 1257
- Can be combined with magnetic floats
- IP 65



GEMÜ 1251/1256
for
GEMÜ 800: DN 25 to 65
GEMÜ 850: DN 25



GEMÜ 1252/1257
for
GEMÜ 850: DN 10 to 20

Instrument sensors

GEMÜ 1270 - 1273

Features

- Electrical instrument sensors with reed contacts for electrical signal transmission
- Can be combined with magnetic floats
- Output signal 1270/1271: 0 – 10 k Ω
- Output signal 1272/1273: 4 – 20 mA
- IP 65
- Raster of reed contacts dependent on version 2.3 – 4.25 mm

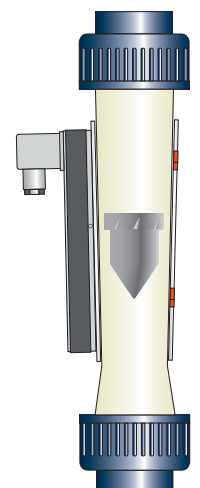
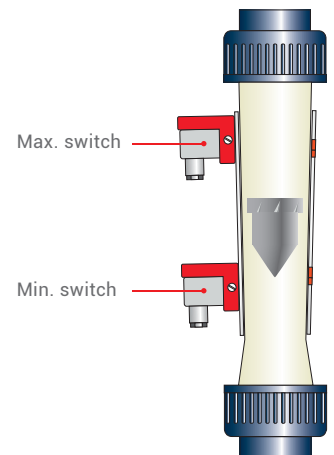

Flow transmitter

GEMÜ 3020, 3021

Technical specifications:

Working medium:	Liquids
Viscosity:	$\leq 120 \text{ mm}^2/\text{s}$
Measuring range:	120 to 25.000 L/h
Accuracy:	$\pm 1\%$ FS (of end value of measuring range)
Reproducibility	$\pm 0.5\%$ FS (of end value of measuring range)
Operating pressure:	max. 10 bar at 20 °C
Media temperature:	0 to 80 °C
Available materials:	Turbine PVDF, turbine body PVC and PVDF
Nominal sizes:	DN 25, DN 50
Automation capability:	Frequency output 0/4 to 20 mA, current output 0 to 10 V, relay signal inputs via PLC or remote operation
Particulars:	Freely scalable measuring range Designed as transmitter and measurement device, GEMÜ 3021 available as batch controller or totalizer



GEMÜ 3020



GEMÜ 3021

Magnetically inductive flowmeter

GEMÜ 3030

Technical specifications:

Working medium:	Liquids
Conductivity of medium:	$\geq 20 \text{ } \mu\text{S}/\text{cm}$
Measuring range:	0 to 4 m/s, 0 to 10 m/s
Accuracy:	$\leq 1\%$ (of end value of measuring range), dependent on installation situation
Operating pressure:	max. 10 bar
Media temperature:	0 to 135 °C
Material of sensor rod:	1.4435/TFM, 1.4435/PEEK
Nominal sizes:	DN 25 to 300
Automation capability:	Frequency output 0/4 – 20 mA, pulse, relay, interface RS-232, Profibus-DP
Particulars:	Choice of measuring ranges, adjustable to changing operating conditions on site



Overview of plastics

Raw materials for plastics comprise homogeneous basic elements, so-called monomers, these being joined to one another in a chemical reaction. At the same time, the C-C double bond is broken with the polymer being formed through linking of the individual molecules.

These chemical reactions are termed polymerisation (subdivided into homopolymers, unipolymers, copolymers and block polymers), polycondensation and polyaddition. The degree of polymerisation is important for thermoplastics and, as a result, the tensile strength, hardness, elongation at fracture and impact strength increase as the degree of polymerisation rises with simultaneous increase in the tendency towards crystallisation, swelling behaviour as well as stress crack formation.

Features

- Low weight due to low density
- Suitability for mass production
- Complex shapes can be produced economically in only a few work steps
- Variable colouration, good dye penetration ability
- Simple improvement of the mechanical properties (tensile strength, elongation at fracture etc.) by filling and strengthening materials
- Plastics have a good internal elasticity and deformation behaviour
- Favourable antifrictional properties
- High chemical resistance



Plastic pellets

Acrylonitrile butadiene styrene polymer – ABS

Acrylonitrile butadiene styrene polymer is an amorphous thermoplastic with many options for variation in its structure. The monomers styrene, butadiene and acrylonitrile form the polymer, which can be reinforced with glass fibres or glass beads. Blends, polyblends, transparent plastics (ABS with corresponding rubber components), copolymers (graft or terpolymers) and special materials are available. ABS is distinguished by high viscosity, also at low temperatures down to -40 °C. This is complemented by high hardness with good scratch resistance. ABS is used in precision and electrical engineering, vehicle construction and the furniture industry, applications including high-quality household appliances as well as pipes and fittings.

Features

- High impact resistance and notch impact strength also at very low temperatures
- Smooth surfaces for low pipe friction losses
- High rigidity
- Physiologically harmless
- No microbial growth on the surface
- Corrosion resistant
- Processing: Injection moulding, extrusion, hot forming, cementing, welding, bolting together (with thread-forming screws), machining
- Scratch-proof surface, very high surface gloss for Prof polymer
- Galvanising suitability
- Metal inserts can be embedded effectively owing to the high viscosity

Resistance to chemicals

- Resistant against:
(Deviations result depending on the portion of the three components styrene, acrylonitrile and butadiene)
Water, aqueous saline solutions, most diluted acids and alkalis, aliphatic hydrocarbons, mineral oils, animal and vegetable fats
- Not resistant against:
Concentrated mineral acids, organic acids, aromatic and chlorinated hydrocarbons, solvents (esters, ethers and ketones)

Thermal properties

- ABS exhibits good thermal stability and can be used in applications from around -45 °C to 60 °C, sometimes to 80 °C.
- ABS is a good thermal insulator; Owing to the high thermal coefficient of linear expansion, this is to be taken into account in the design of pipe systems

Electrical properties

- ABS exhibits a high surface and volume resistivity at only very low electrostatic build-up and also has good electric insulating performance. This must be considered for applications where there is a risk of ignition or explosion.

Fire behaviour

- Burns with a sooting flame without dripping. In accordance with UL94, ABS is classified into the flammability classification HB (horizontal burning). Types with flame-retardant standardisation are available.

Disadvantages

- Not very weatherproof

Polyamides PA

Polyamides are construction plastics for many technical applications, in particular for machine elements. Apart from copolyamides and polyamide 6-3-T, all others are semi-crystalline. Amorphous polyamides such as PA 6-3-T are almost transparent and are used at GEMÜ for flowmeters amongst other applications.

Polyamides absorb the moisture reversibly and release it again, their properties changing in the process.

Areas of application include mechanical engineering, precision engineering, vehicle construction, electrical engineering, sanitation technology, as well as the construction and furniture industry.

Features

- (at high crystallinity) rigid and hard
- Very viscous after absorbing water
- High fatigue strength
- Good impact resistance and notch impact strength, increased with modified types
- Good abrasion and wear resistance
- Good hydrolysis resistance
- Good antifrictional and antiseizure properties

- Good tracking resistance and dielectric strength
- With injection moulding: Good flow velocity, tremendous demoulding capacity
- Processing: Injection moulding, extrusion, cementing (better with low crystallinity), welding, bolting together, machining, printing, painting, metallising in high vacuum, fluidised bed sintering, flame spraying or electrostatic coating

Resistance to chemicals

- Resistant against:
Very many organic media, e.g. esters, ethers, many chlorinated hydrocarbons, aliphatic and aromatic hydrocarbons, numerous mineral oils, greases, petrol, saline solutions, some alcohols, halogenated aliphatics and aromatics, petrol, oils, greases, weak alkalis and (mineral) acids, diluted alkalis
- Not resistant against:
Mineral acids, strong alkalis, solutions of oxidants, low aliphatic alcohols, acetone, ketones and aldehydes (only to a limited extent)

Thermal properties

- The application temperature is between approx. -40 to +80 °C, depending on the type. Heat-stabilised types are available, which can withstand a longer influence above 120 °C without harmful effects

Electrical properties

- The electrical properties depend on the water content. The favourable surface resistance prevents extensive static build-up. Good tracking resistance, good insulation capacity (also with the effects of moisture), low electrolytic corrosion and high dielectric strength distinguish this material

Fire behaviour

- PA burns bluish with a yellow edge, drips with crackling
- Most types of PA achieve fire class HB to V2 according to UL94, and up to V0 with flame retardant

Disadvantages

- Water absorption affects material properties. For permanent use with outside weathering; UV-stabilised types should be used above all with exposure to sunlight

Overview of plastics

Polypropylene

PP-H / PP natural / PP reinforced

Polypropylene has been manufactured on an industrial scale since 1957 through the polymerisation of propylene using Ziegler-Natta catalysts. It belongs to the group of olefins which also include polyethylene (PE). A distinction is made between the PP moulding compounds in homopolymers (PP-H), block-copolymer (PP-B) and random-block-copolymers (PP-R). PP-H is used in pipe construction and equipment, as it exhibits many favourable properties such as resistance to chemicals and corrosion, stress crack resistance and, above all, an excellent weldability.

PP is a semi-crystalline, extensively non-polar thermoplastic, exhibiting a higher rigidity, hardness and strength in comparison to PE. As a thermoplastic with the lowest density at around 0.9 g/cm³, it occurs with a crystallinity between 60 to 70%. The addition of nucleating agents results in a fine-grain structure, exhibiting an increased (cold) impact strength. A reinforcement comprising glass fibres or minerals is recommended for construction components subject to high stress.

Features

- Good chemical resistance
- Excellent weldability
- High thermal aging and heat distortion temperature
- Application temperature: 5 to +90 °C, depending on the pressure and medium
- High impact strength, which decreases slightly at temperatures below 0 °C
- Fire behaviour: Burns; in UL94 as HB (horizontal burning) according to DIN 4102 T1
- Low tendency to form stress cracks
- Processing by: Injection moulding, extrusion, extrusion blow moulding, hot forming, no effective bonding strength owing to high chemicals resistance and non-polar structure (after pre-treatment cementing with adhesive and contact bonding material), machining, printing, painting, metallising
- Requires stabilisation

Resistance to chemicals

- Resistant against:
Aqueous solutions of inorganic salts, weak inorganic acids and alkalis, alcohol, some oils, solutions of standard washing liquors to +100 °C

- Not resistant against:
Strong oxidants, halogenated hydrocarbons, ketones, chlorinated hydrocarbons, petrol and benzene. Swelling in aliphatic and aromatic hydrocarbons (especially at increased temperatures). Partially non-resistant upon contact with copper! Inserts made of copper, manganese, cobalt and their alloys are to be avoided!

Thermal properties

- PP is a good thermal insulator. Pure PP tends towards oxidation at high temperatures. Stabilised types are therefore used.

Electrical properties

- Favourable dielectric properties irrespective of temperature and frequency (hence no HF warming). The high electrical insulating properties lead to electrostatic build-up and dust attraction. On account of this electrostatic build-up, care must be taken in applications where there is a risk of ignition or explosion, or corresponding countermeasures are to be implemented.

UV resistance

- The short-wave UV spectra of sunlight damage the PP together with the atmospheric oxygen. A covering in the form of an insulation or by a coat of paint absorbing UV light should be attached or applied.

Polyvinylchloride, unplasticised – PVC-U

Polyvinyl chloride is a bulk plastic which has been produced on an industrial scale since the beginning of the 20th century, its use coming in third place behind polyethylene and polypropylene. It is now indispensable in many applications in industry as well as for products in everyday life. PVC exhibits a very good overall ecological balance on account of its high component of chlorine of around 56 % by weight. Different manufacturing methods give rise to the various PVC polymers PVC-U, PVC-P, PVC-C, PVC-E, PVC-S or PVC-M with special properties. These are determined by the average degree of polymerisation (K value). An increase in the K value therefore increases the viscosity, dimensional stability in heat and fatigue strength at simultaneous decrease in the processability. PVC-U is primarily used in pipe construction, also PVC-C and transparent PVC-S in lower quantities.

PVC-U is an amorphous, polar thermoplastic. The cementing of pipes and valve bodies made of PVC-U is generally carried out with highly-solvent, gap-filling solvent adhesives.

Features

- Very good chemical resistance
- Good resistance to light and weathering, if sufficiently stabilised
- Physiologically indifferent
- High mechanical strength, rigidity and hardness
- Application temperature: 0 to 60 °C, depending on the pressure and medium
- Fire behaviour: Highly sooting with yellow flame, self-extinguishing flammability class V0 according to UL94, building material class B1 (hardly flammable) according to DIN 4102
- Low stress crack formation
- Processing by: Injection moulding, extrusion, hot forming, cementing, welding, machinable

Resistance to chemicals

- Resistant against:
Saline solutions, sea water, diluted and partially concentrated acid, diluted and concentrated alkalis, non-polar solvents, petrol, mineral oils, greases, alcohol, aliphatic hydrocarbons, elemental chlorine, relatively good against high-energy radiation. UV radiation reduces the impact resistance slightly
- Not resistant against:
Polar, aromatic and chlorinated solvents, esters, chlorinated hydrocarbons, aromatic hydrocarbons, petrol, liquid halogens, sulphuric acid containing oleum, concentrated nitric acid. An application with gas is not recommended, as PVC-U valve bodies tend towards chip fracture

Thermal properties

- PVC-U is a good thermal insulator on account of the very low thermal conductivity. Despite the lower linear coefficient of thermal expansion, this must be taken into account in the design of pipes

Energy balance

- PVC-U is average in this respect. The energy balance is low during manufacturing, which has a positive effect in relation to the durability of the products

Polyvinylidene fluoride – PVDF

Polyvinylidene fluoride is a semi-crystalline thermoplastic, which can be processed using the injection moulding process in contrast to PTFE. The combination of extreme thermal stability with the best chemical resistance of all plastics allows PVDF to be used in industrial line construction, in the foodstuff industry for packaging films and for coating measuring probes and loudspeakers thanks to its piezoelectric effects. PVDF has a fluorine content of 59 % and can be processed well into moulded parts in contrast to PTFE, which cannot be processed thermoplastically.

Features

- High strength and rigidity at high temperatures
- High fatigue strength
- High UV resistance
- High resistance to chemicals
- High impact strength even in the cold
- Very low water absorption
- Self-extinguishing
- Physiologically harmless
- No microbial growth
- No electrolytic corrosion
- Application temperature: -20 to 120 °C, depending on the pressure and medium

Resistance to chemicals

- Resistant against:
Most organic and inorganic acids, aliphatic and aromatic hydrocarbons, alcohols and halogenated solvents, dry and moist halogens
- Not resistant against:
Alkalis, alkali metals, highly alkaline amines, elemental fluorine. Slight swelling due to highly polar solvents

Thermal properties

- PVDF is a good thermal insulator. Owing to the high thermal coefficient of linear expansion, this is to be taken into account in the design of pipe systems

Overview of plastics

Electrical properties

- PVDF is a good electrical insulator. The high electrical insulating properties can lead to electrostatic build-up and dust attraction. On account of this electrostatic build-up, care must be taken in applications where there is a risk of ignition or explosion, or corresponding countermeasures are to be implemented

Fire behaviour

- Does not burn and is classified into flammability class V0 according to UL94. A material decomposition begins at 380 °C, elemental fluorine being released, which reacts exothermally to form hydrogen fluoride in the presence of water

Polysulphones – PES and PSU

Amorphous, polar thermoplastics exhibiting a high heat deflection temperature and resistance to chemicals. The transparent, partially crystal-clear material PSU is used for flowmeters at GEMÜ. Both materials are also used for mechanical, thermal and electrical construction parts which are subject to high stress and for which transparency is required. Polysulphones have a broad field of application in precision and electrical engineering, vehicle and aircraft construction as well as household appliances.

Features

- Good strength and rigidity at higher temperatures
- Low creep tendency at higher temperatures
- Good viscosity also at higher temperatures
- Water absorption affects mechanical strength similar to polyamide
- PES has a higher permanent application temperature than PSU
- Colour transparent, almost crystal-clear, can be dyed covered in various colours
- Physiologically harmless

Resistance to chemicals

- Resistant against:
Diluted acids and alkalis, petrol, oils, greases, alcohols, hot water and steam (PSU), high-energy radiation and infrared radiation

- Not resistant against:
PES without stabilisation not weatherproof and UV-resistant, polar organic solvents, esters, ketones, aromatic hydrocarbons and hydrocarbons containing chlorine, petrol

Thermal properties

- PSU has high permanent application temperatures, which are even higher for PES. Application temperatures range from -80 °C at good viscosity to 180 °C at low creep tendency

Electrical properties

- For polar plastics good electrical insulating properties and low dielectric losses also at higher temperatures and humidity

Fire behaviour

- Hardly flammable, pungent odour of incendiary fumes

Disadvantages

- Stress crack formation possible with some media;
Notch impact sensitivity

Worldwide presence

AUSTRALIA

GEMÜ Australia Pty. Ltd
Unit 4 - 8/10 Yandina Road
West Gosford, NSW 2250
Phone: +61-2-43 23 44 93
Fax: +61-2-43 23 44 96
mail@gemu.com.au

AUSTRIA

GEMÜ GmbH
Europaring F15 401
2345 Brunn am Gebirge
Phone: +43 22-36 30 43 45-0
Fax: +43 22-36 30 43 45-31
info@gemue.at

BELGIUM

GEMÜ Valves bvba/sprl
Koning Albert 1 laan, 64
1780 Wemmel
Phone: +32 2 702 09 00
Fax: +32 2 705 55 03
info@gemue.be

BRAZIL / SOUTH AMERICA

GEMÜ Indústria de Produtos Plásticos e Metalúrgicos Ltda.
Rue Marechal Hermes, 1141
83.065-000 São José dos Pinhais Paraná
Phone: +55-41-33 82 24 25
Fax: +55-41-33 82 35 31
gemu@gemue.com.br

CANADA

GEMÜ Valves Canada Inc.
2572 Daniel-Johnson Boulevard
Laval, Quebec
H7T 2R8
Phone: +1-450-902-2690
Fax: +1-404-3 44 4003
info@gemu.com

CHINA

GEMÜ Valves (China) Co., Ltd
No.518, North Hengshahe Road
Minhang District, 201108
Shanghai
Phone: +86-21-2409 9878
info@gemue.com.cn

DENMARK

GEMÜ ApS
Industriparken 16-18
2750 Ballerup
Phone: +45 70 222 516
Fax: +45 70 222 518
info@gemue.dk

FRANCE

GEMÜ S.A.S
1 Rue Jean Bugatti
CS 99308 Duppigheim
67129 Molsheim Cedex
Phone: +33-3 88 48 21 00
Fax: +33-3 88 49 12 49
info@gemu.fr

INTERCARAT

1 Rue Jean Bugatti
CS 99308 Duppigheim
67129 Molsheim Cedex
Phone: +33-3 88 48 21 20
Fax: +33-3 88 49 14 82
sales@intercarat.com

GERMANY

GEMÜ Gebr. Müller GmbH & Co. KG
Fritz-Müller-Straße 6 - 8
74653 Ingelfingen-Criesbach
Postfach 30
74665 Ingelfingen-Criesbach

Phone: +49 (0)7940-12 30
Fax: +49 (0)7940-12 31 92 (Domestic)
Fax: +49 (0)7940-12 32 24 (Export)
info@gemue.de

Inevvo solutions GmbH & Co. KG
Fritz-Müller-Platz 1
74676 Niedernhall-Waldzimmern
Phone: +49 (0)7940-12 38 681
info@inevvo-solutions.com

GREAT BRITAIN / UK

GEMÜ Valves Ltd.
10 Olympic Way
Birchwood, Warrington
WA2 0YL
Phone: +44-19 25-82 40 44
Fax: +44-19 25-82 80 02
info@gemu.co.uk

HONG KONG

GEMÜ (Hong Kong) Co., Ltd.
Room 2015, Tower B,
Regent Centre,
70 TA Chuen Ping Street
Kwai Chung, N.T., Hong Kong
P.R. China
Phone: +852 6873 8280
Fax: +852 6873 8280
info@gemue.com.cn

INDIA

GEMÜ India
Representative Office
301, K.B. Complex, Rambaug,
L.G.Hospital Road, Maninagar,
Ahmedabad-380 008
Phone: +91-79-25450438
+91-79-25450440
Fax: +91-79-25450439
sales@gemu.in

INDONESIA

GEMÜ Valves Pte Ltd
(Indonesia Representative Office)
Rukan Mangga Dua Square
Block F17, 2nd Floor
Jl. Gunung Sahari Raya No. 1
Jakarta Utara 14420
Indonesia
Phone: +62 (21) - 6231 0035
Fax +62 (21) - 2907 4643
info@gemu.co.id

IRELAND

GEMÜ Ireland Ltd
15 Eastgate Drive
Eastgate Business Park
Little Island
Co. Cork
Phone: +353 (0)21 4232023
Fax: +353 (0)21 4232024
info@gemu.ie

ITALY

GEMÜ S.r.l.
Via Giovanni Gentile, 3
20157 Milano
Phone: +39-02-40044080
Fax: +39-02-40044081
info@gemue.it

JAPAN

GEMÜ Japan Co., Ltd.
2-5-6, Aoi, Higashi-ku,
Nagoya, Aichi, 461-0004
Phone: +81-52-936-2311
Fax: +81-52-936-2312
info@gemu.jp

MALAYSIA

GEMÜ VALVES PTE LTD
(Malaysia Representative Office)
D-8-09, Block D, No. 2A
Jalan PJU 1A/7A
Oasis Square, Oasis Damansara
47301 Petaling Jaya
Selangor Darul Ehsan
Phone: +(603)- 7832 7640
Fax: +(603)- 7832 7649
info@gemu.com.sg

MEXICO

GEMÜ Valvulas S.A. de C.V.
German Centre,
Av. Santa Fe No. 170 - OF. 5-1-05
Col. Lomas de Santa Fe,
Del. Alvaro Obregon
01210 Mexico, D.F.
Phone: +52 55 7090 4161
+52 55 7090 4179

RUSSIA

OOO „GEMÜ GmbH“
Uliza Shipilovskaya, 28A
115563, Moskau
Phone: +7(495) 662-58-35
Fax: +7(495) 662-58-35
info@gemue.ru

SINGAPORE

GEMÜ Valves PTE. LTD.
25 International Business Park
German Centre #03-73/75
Singapore 609916
Phone: +65-65 62 76 40
Fax: +65-65 62 76 49
info@gemu.com.sg

SOUTH AFRICA

GEMÜ Valves Africa Pty. Ltd
Stand 379
Northlands Business Park,
Hoogland Ext 45
Northriding, Randburg
Phone: +27(0)11 462 7795
Fax: +27(0)11 462 4226
office@gemue.co.za

SWEDEN

GEMÜ Armatur AB
Box 5
437 21 Lindome
Phone: +46-31-99 65 00
Fax: +46-31-99 65 20
order@gemu.se

SWITZERLAND

GEMÜ GmbH
Seetalstr. 210
6032 Emmen
Phone: +41-41-7 99 05 05
Fax: +41-41-7 99 05 85
info@gemue.ch

GEMÜ Vertriebs AG

Lettenstrasse 3
6343 Rotkreuz
Phone: +41-41-7 99 05 55
Fax: +41-41-7 99 05 85
vertriebsag@gemue.ch

TAIWAN

GEMÜ Taiwan Ltd.
9F.-5, No.8, Ziqiang S. Rd.
Zhubei City
Hsinchu County 302,
Taiwan (R.O.C.)
Phone: +886-3-550-7265
Fax: +886-3-550-7201
office@gemue.tw

UNITED STATES

GEMÜ Valves Inc.
3800 Camp Creek Parkway
Suite 120, Building 2600
Atlanta, Georgia 30331
Phone: +1-678-5 53 34 00
Fax: +1-404-3 44 93 50
info@gemu.com

In addition to these subsidiaries, GEMÜ has a global partner network.

Contact details:

https://www.gemu-group.com/en_GB/kontakte/



 GEMÜ manufacturing site

 GEMÜ subsidiary

