

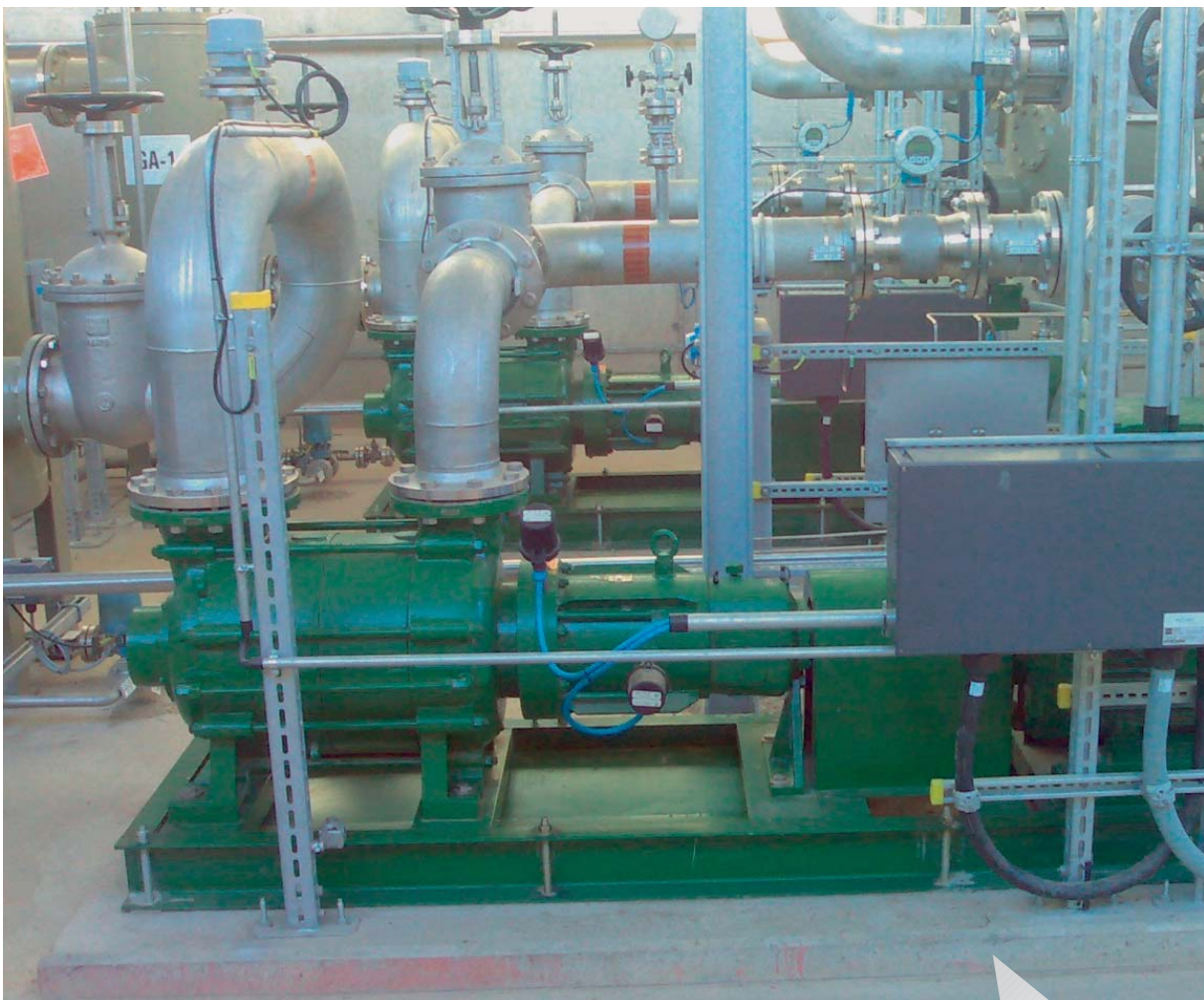

**DICKOW
PUMPEN**

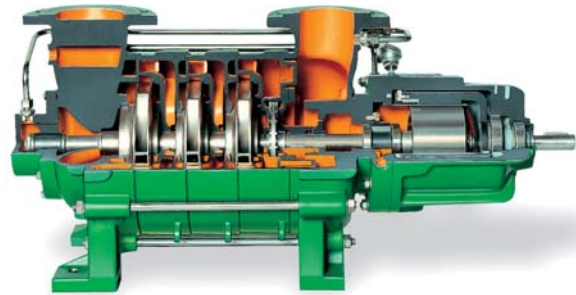

**Sealless Magnetic Coupled
Multistage Centrifugal Pumps
with Priming Stage
Type HZSM / HZSMB / HZSMR /
HZSMA / HZSMAR**

*our
contribution
for
environmental
protection*

General

DICKOW-pumps of series HZSM are sealless multistage horizontal centrifugal pumps, driven by a synchronous permanent magnetic coupling. The static containment shell forms a closed system with hermetically sealed liquid end. The integrated side channel stage allows the handling of entrained gas and operation under suction lift conditions.

Application

Magnetic driven HZSM-pumps are designed to improve plant and personnel safety, especially when handling toxic, explosive or other dangerous liquids which react on contact with the atmosphere. For all these services the containment shell replaces the double acting mechanical seal with external fluid reservoirs and the necessary control equipment. HZSM-pumps therefore offer exceptional benefits to the chemical, petrochemical and allied industries, and protect the environment.

The HZSM-type is used in tank farms, for offloading rail cars and trucks, filling of storage tanks and other applications where priming of empty suction pipes is required.

Considering low NPSH-values, gas handling capability and sealless design, the HZSMA-type offers special benefits to liquified gas applications. Typical application is filling of LPG-trucks and rail cars in refineries.

The maximum operating temperature is 180°C.

Hazardous area

Together with the required Ex-drive motors, the HZSM-pumps can be applied in hazardous area Group II, Category 2. The pumps meet the basic safety and health requirements of Explosion-proof Directive 94/9 EC and are suitable for plants with increased safety requirement.

For close coupled pumps (HZSMB) the containment shell temperature is limited when using ex-motors. The values are available on request.

Design / Casing

HZSM-pumps are multistage between bearings ring section pumps with closed impeller, end suction and top discharge flange. Suction and discharge casing are provided with sturdy feet for mounting on base plate.

The pump flanges of HZSM-pumps are provided principally in vertical top position to grant a certain quantity of liquid in the pump which is necessary for priming empty suction pipes and lifting pumping liquid from underground storage facilities. For obtaining low NPSH-value, the suction casing is designed in volute shape.

The HZSMA-pumps - for applications with flooded suction conditions - are provided with suction casings of end suction design to obtain further reduction of NPSH-values.

Containment shell

The containment shell is designed as a pressurized vessel to separate the pumpage from the atmosphere. The containment shell is not used as an additional bearing holder. No dynamic stress occurs.

The containment shell is bolted to the bearing housing in a manner that allows removal of the bearing bracket (HZSM-pumps) respectively of the drive motor (HZSMB-pumps) together with the drive rotor without draining the pump.

Priming stage

The side channel stage is capable to evacuate the suction line and therefore, to selfprime if initially filled with operating liquid. In the priming phase the side channel pump works as a positive displacement pump. The displacement effect is created by a rotating liquid ring which enters and exits the side channel in a piston fashion by each rotation. This is generated by an interrupter in the side channel which separates suction and pressure area. The piston effect conveys the gas from suction to discharge side. The priming stage works automatically, no auxiliary vent equipment is required.

When pumping LPG, attention has to be paid to gas entrainment by vapor bubbles. In practice, these pumps can pump this liquid-gas-mixtures without auxiliary device. Due to the increased pressure in the side channel stage, the gas bubbles turn into liquid phase again.

Magnetic coupling

The single elements of the multipolar magnetic coupling are manufactured of permanent magnet material "Cobalt Samarium" with unlimited lifetime. The magnets in the driven rotor are completely encapsulated, not in contact with liquid. Power is transmitted to the hermetically sealed liquid end by a bank of external magnets. Inner and outer magnet rings are locked together by magnetic forces and work as a synchronous coupling. The inner magnet ring transmits the required torque direct to the impeller. Overload of the magnetic coupling and slipping will not cause demagnetization if temperature monitoring is available. The magnetic drives are designed for electric motors, direct on line starting. Should a subsequent increase of motor power be required, i.e. when installing larger impellers, the nominal power of coupling can be increased with additional magnets.

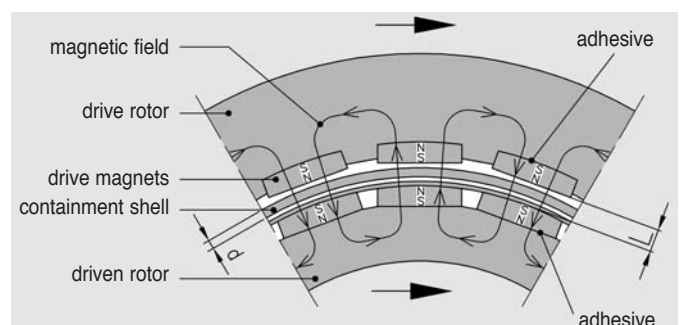

Double sleeve bearings

The pump shaft is carried by wetted sleeve bearings. Standard material is pure Silicon Carbide with diamond layer, providing limited dry-run capability. SiC is highly resistant to corrosion and wear and can be used for all kind of liquids. The SiC-components are shrinkfitted or elastically beared by tolerance rings and therefore protected against shock and thermal stress.

Internal cooling flow

When the pump is in operation, eddy currents are developed inside the metallic containment shells and converted into heat in the magnet area.

In order to avoid inadmissible temperature rise of the pumped fluid, this heat is dissipated through an internal cooling flow.

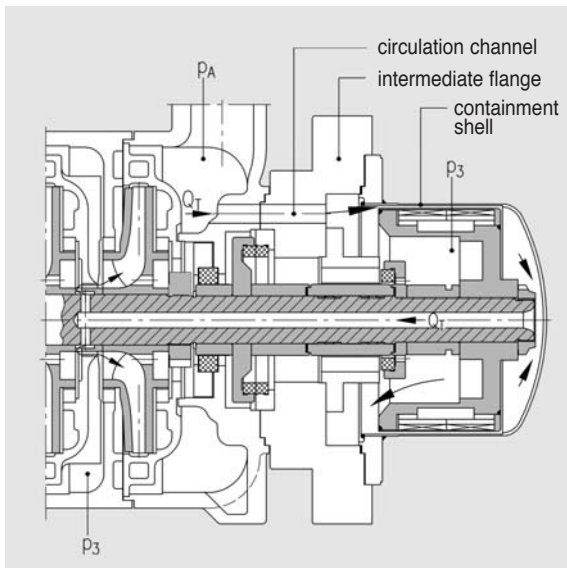

Outer ball bearings

The drive shaft of the HZSM-pumps is carried by generously dimensioned antifriction bearings, grease filled for lifetime and protected against the atmosphere by a lip seal.

The drive rotor of HZSMB-pumps is mounted on the motor shaft. That means, additional bearings, elastic coupling and coupling alignment are not required.

The drive shaft of HZSMR-pumps is carried by generously dimensioned oil lubricated antifriction bearings. The bearings are rated for 25000 operating hours. The oil bath is protected against the atmosphere by a contactless labyrinth seal.

Oil level is controlled by constant level oiler. The oil chamber is sealed from the magnet chamber also by labyrinth seal.

Impellers, NPSH-values

When operating hermetically sealed pumps, cavitation must be avoided by all means. This applies especially for handling hydrocarbons, condensates and other low boiling liquids.

For lowest NPSH-values, the impeller of the first stage is designed as a suction impeller with enlarged eye.

Balanced thrust loads

The thrust loads of the closed impellers are balanced by throttle gap and relief holes. The balancing of residual loads is effected by the balancing disc on pressure side.

The front side of the balancing disc is pressurized by the pump pressure p_1 .

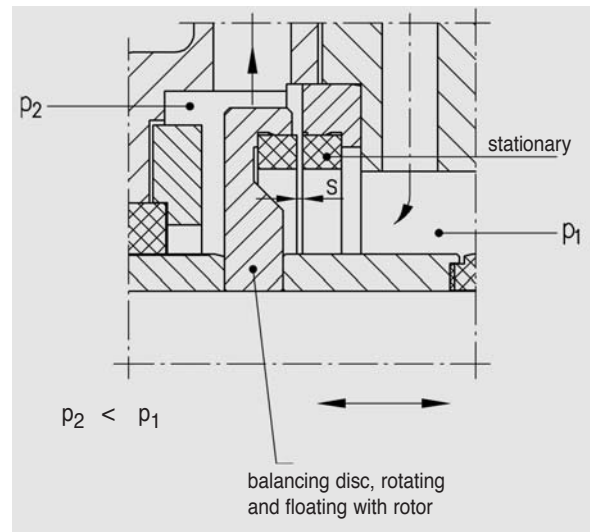

The rear disc side is connected with the pressure side of the first pump stage via an external pipe. According to the rotor position and the adjusting gap S , a counter force is created by the differential pressure between front and rear side of the balancing disc. This counter force acts against the residual load towards the containment shell such that no thrust loads occur. No thrust bearings are required. The start-up rings keep the pump shaft in position during start-up and shut-off.

Monitoring

Connection for temperature detection element for containment shell surface temperature is available as standard. Dry running protection and monitoring of ball bearings and containment shell temperature with the patented "mag-safe" system is highly recommended.

HZSM-Design

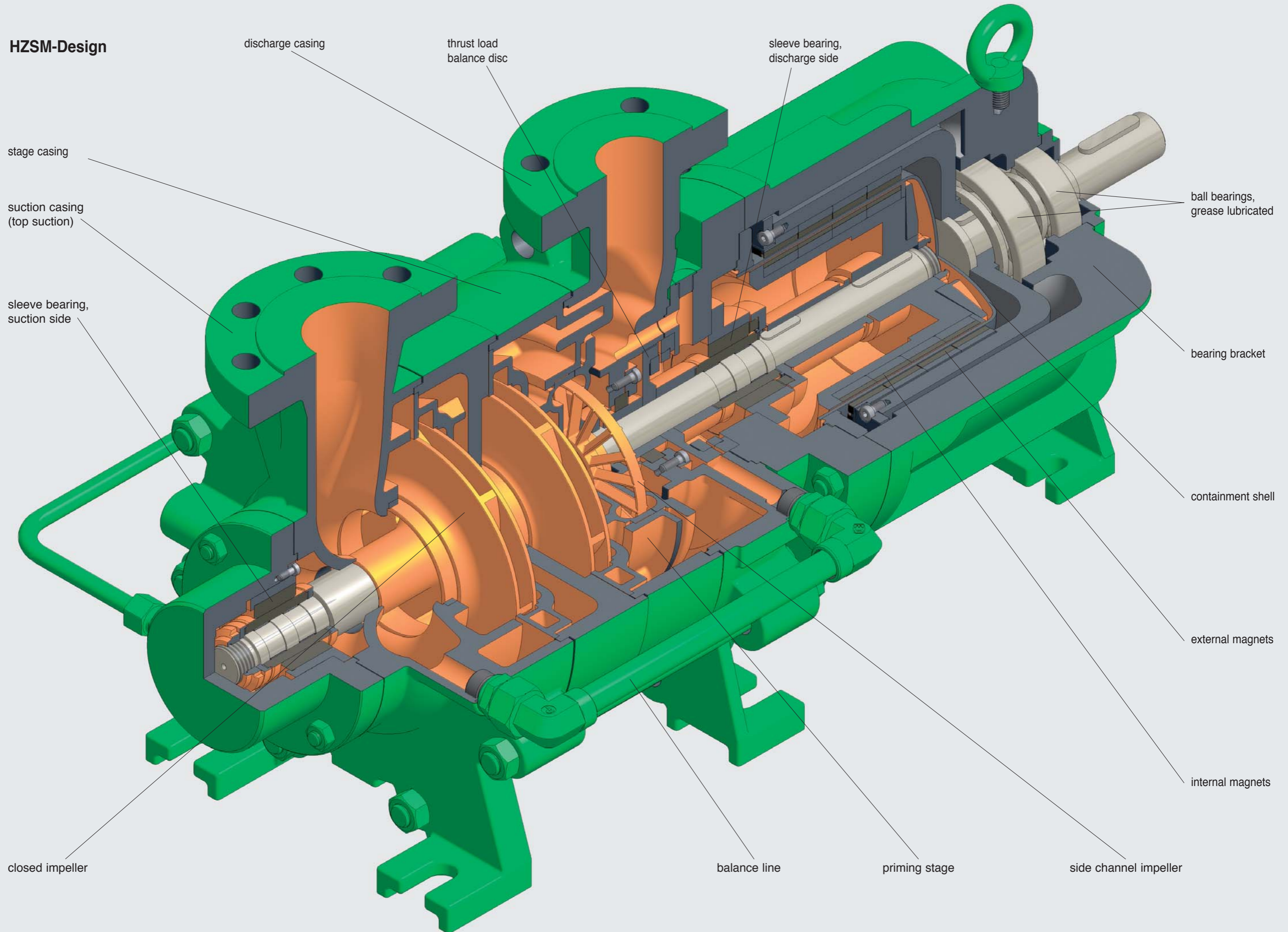

Optional designs – HZSM, self-priming

Type HZSMB – top suction, close coupled execution

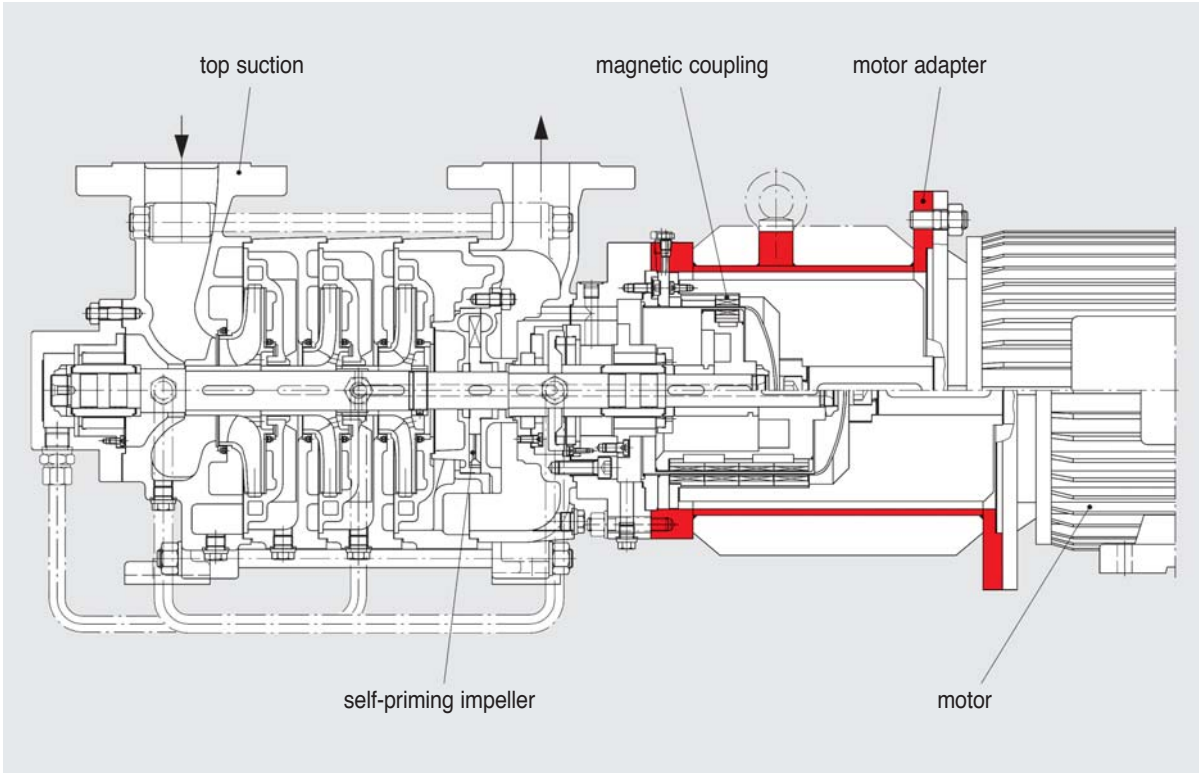

Type HZSMR – top suction with oil lubricated bearing bracket

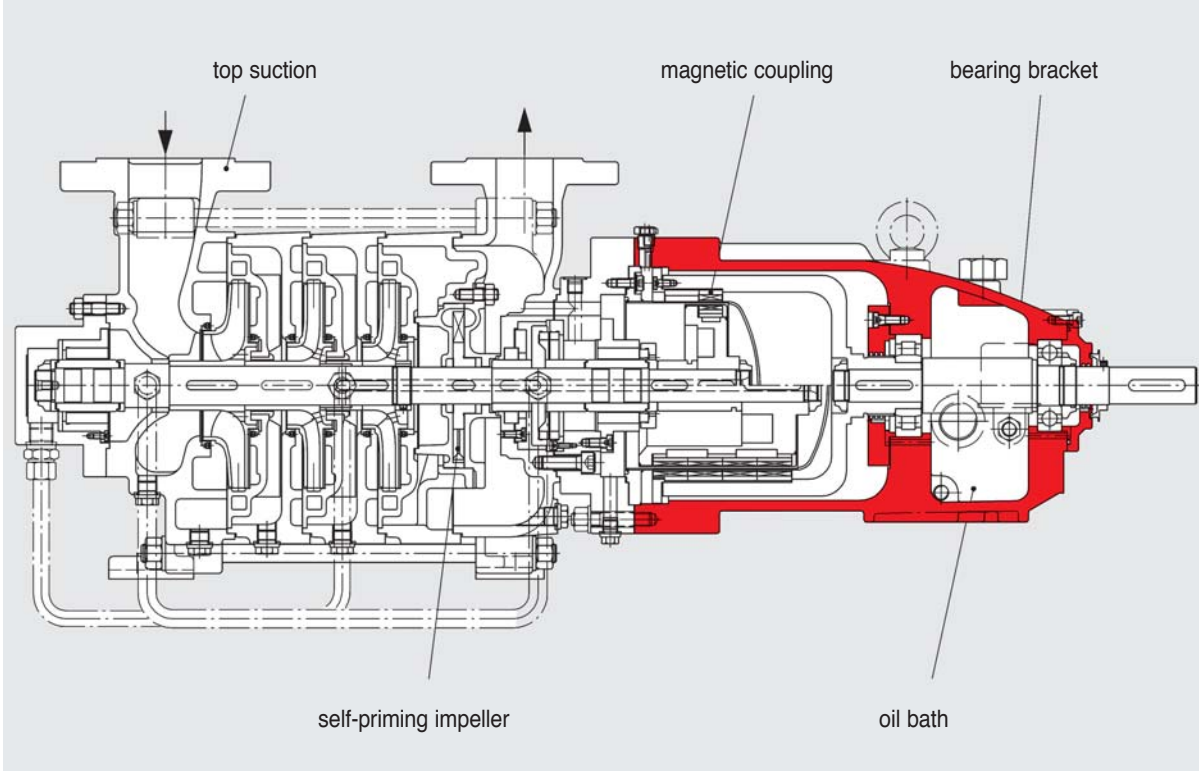

Optional designs – HZSMA, for handling of liquified gases

Type HZSMA – end suction with grease lubricated bearing bracket

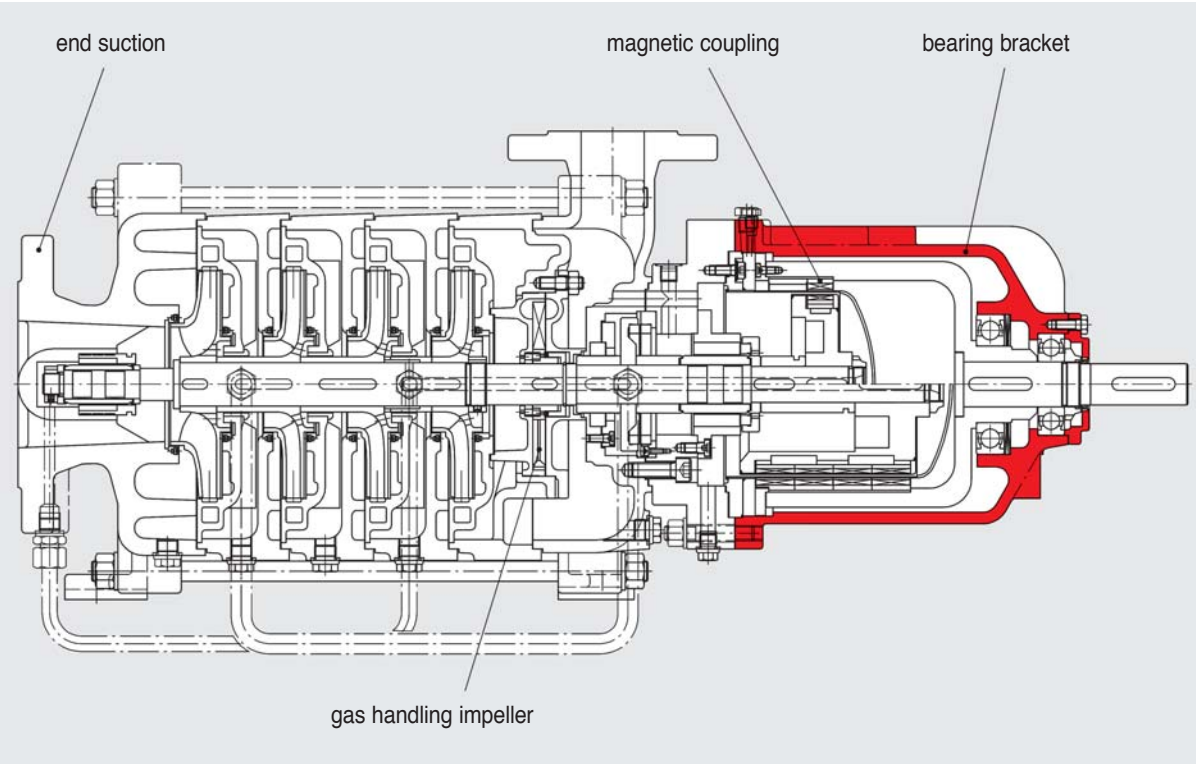

Type HZSMAR – end suction with oil lubricated bearing bracket

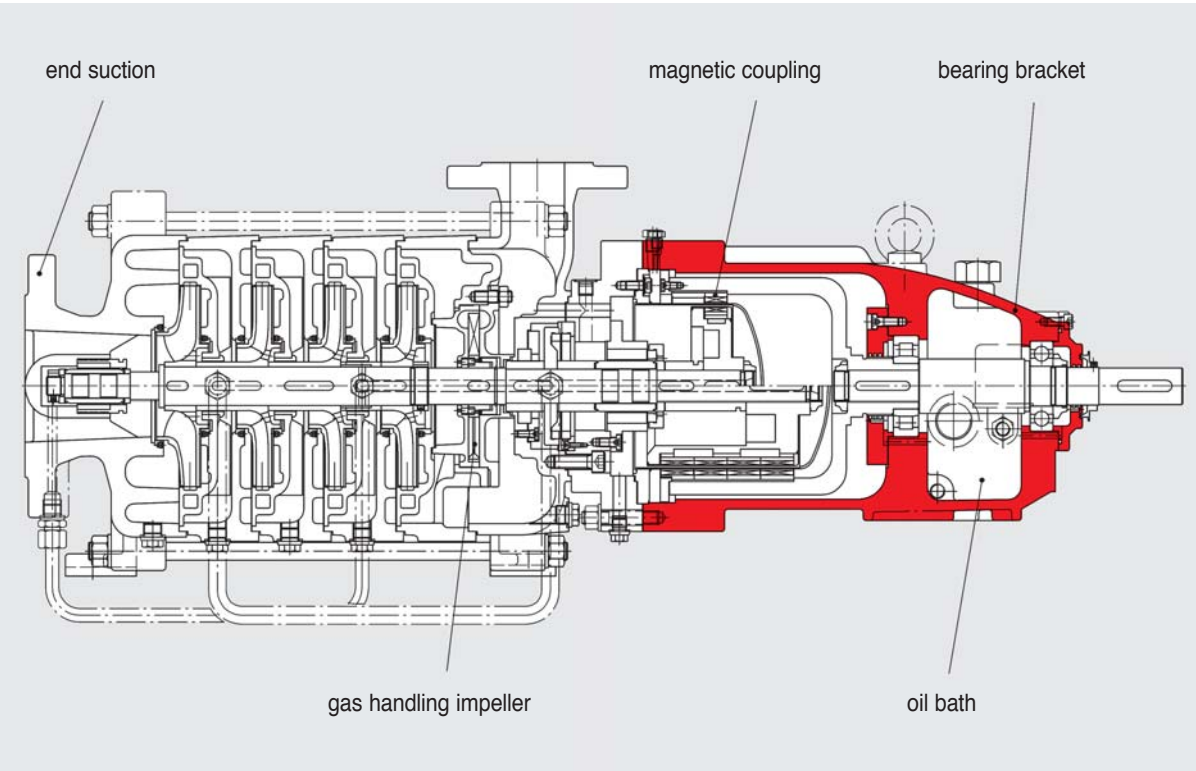

Performance range

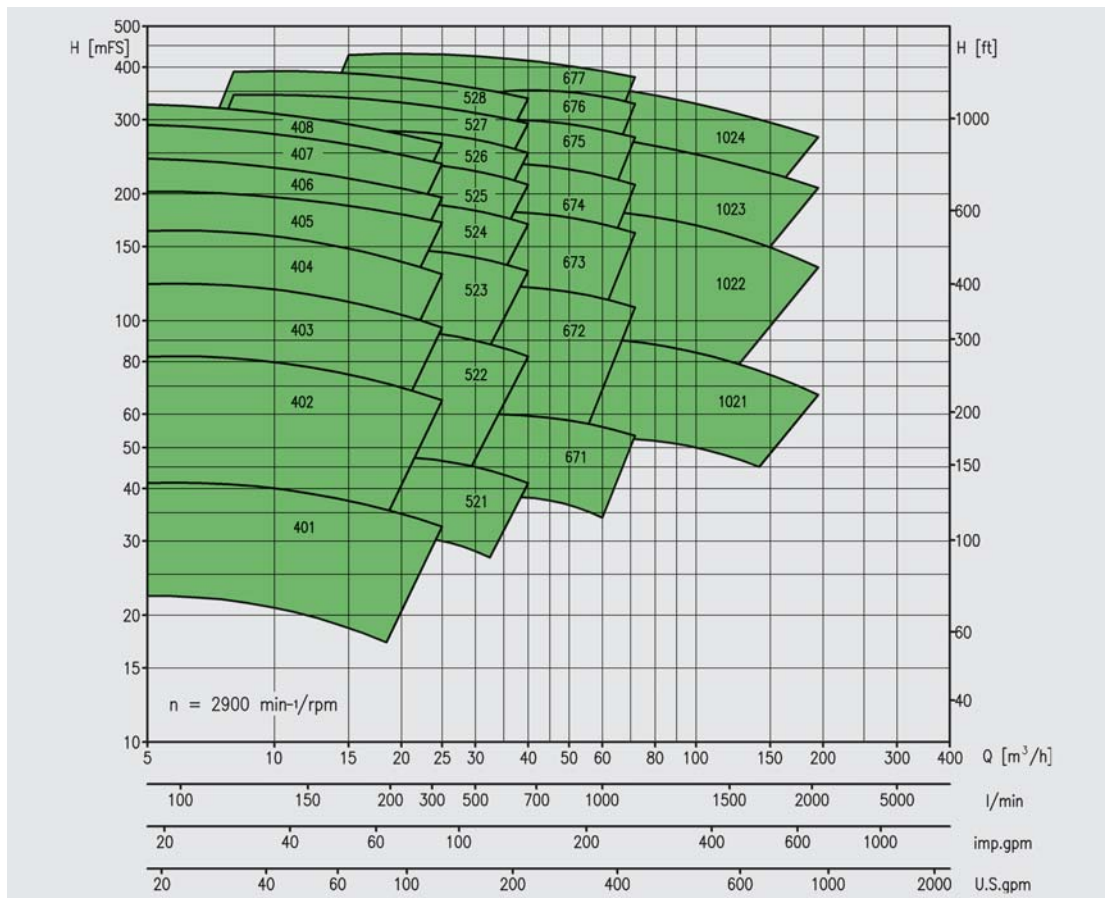
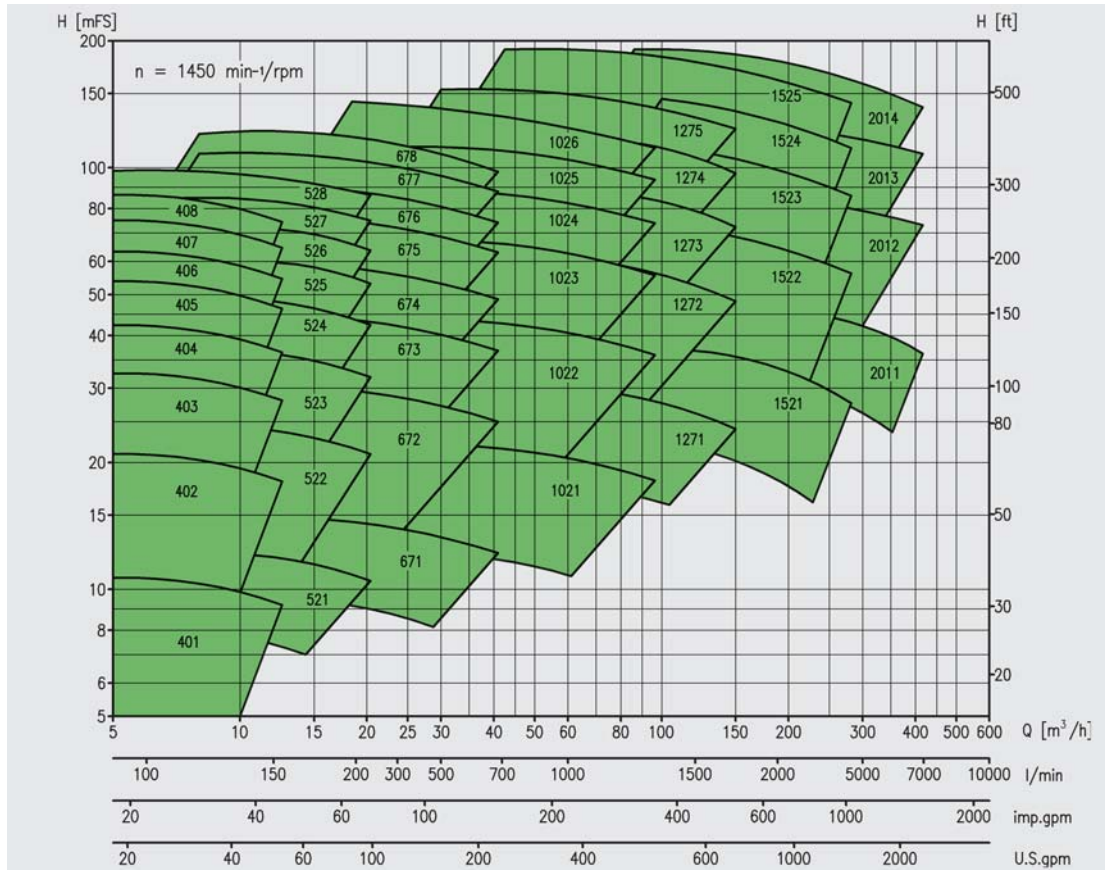

Performance curves for the individual pump sizes, also for 1750 / 3500 rpm, with NPSH-values and power consumption, are available on request.



DICKOW PUMPEN GmbH & Co.KG
 Postfach 1254
 84465 Waldkraiburg · Germany
 Tel. ++ 49 86 38 6 02 0
 Fax ++ 49 86 38 6 02 200 + 6 02 201
 info@dickow.de / export@dickow.de
 www.dickow.de

