

AFT-DV DN100 - DN4000

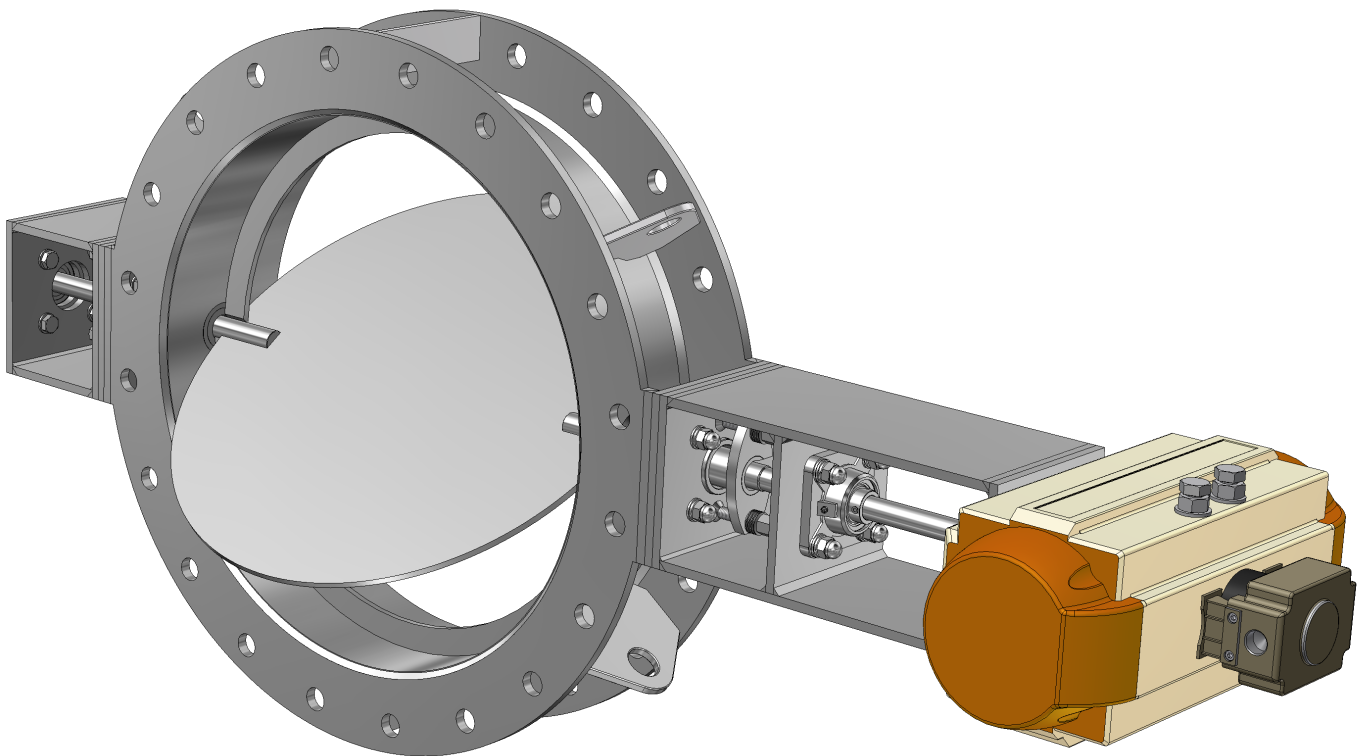

Damper valve for round channels

Technical description

Damper valves type AFT-DV serve for the shut-off and/or flow regulation of medium (air or process gas).

Such valves find application in flue gas extraction installations, flue gas desulphurisation, gas utilisation SO₂, SO₃, NO_x, dedusting of furnaces, glass factories, metallurgical plants for copper, zinc, plumb as well as cement factories, etc.

The construction is of welded nature, discs can be joined with shafts by welding (fixed discs) or by pins (dismountable discs).

For special high temperature applications ceramic lining inside the body is available according to customer requirements.

Product properties

Diameter range

DN100 – DN4000
(larger sizes on request)

Mounting connection

- flanges acc. to DIN 24154
- flanges PN6, PN10, PN16 (acc. to EN1092-1)
- custom-made acc. to custom requirements (ANSI / GOST / other)
- welding ends

Design pressure

< 0,5 bar

Temperature range

-20°C to +750°C or acc. to customer request
(max. working temperature up to 1100°C)

Mounting of actuator

- acc. to ISO 5211
- customized acc. to customer requirements (for linear actuators and actuators with driving levers)

Gland packing

- graphite (other depending on medium and temperature)
- with sealing air

Working positions of damper valve

- horizontal shaft
- vertical shaft
- shaft at required angle

Geometric tightness according to constructional solution applied

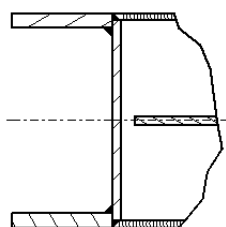

Geometric tightness >95%

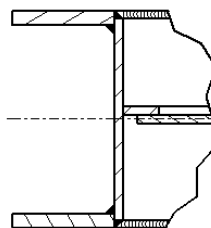

Geometric tightness >98%

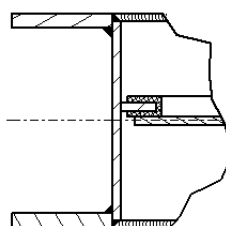

Geometric tightness >99% (soft sealing) Greater tightness is achieved by special profiled band mounted on seat ledges or sealing profile mounted directly on disc edge

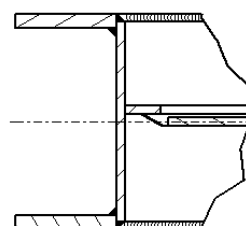

Geometric tightness >99% (metal sealing) Greater tightness is achieved through metal sealing by high alloy steel; high elasticity, high anticorrosivity and resistance to high temperatures

Flange version

For welding version

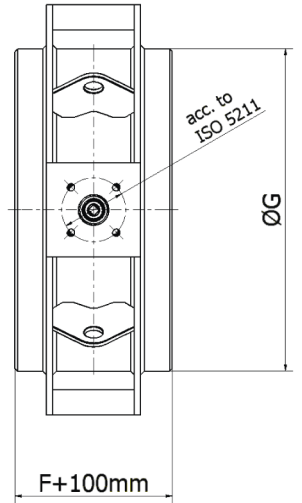
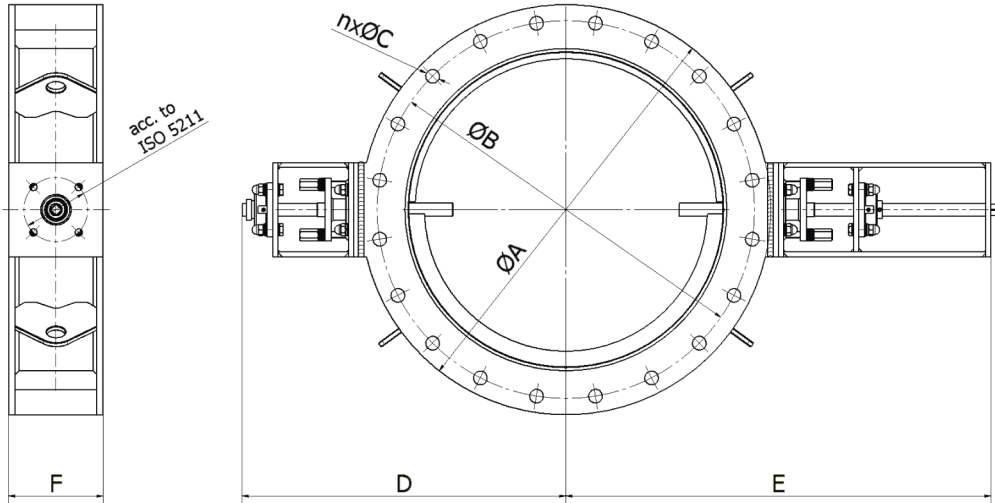

ØG – Outside diameter of pipe and wall thickness acc. to inquiry

DN	EN 1092-1 PN 6						
	ØA [mm]	ØB [mm]	n -	ØC [mm]	D(*) [mm]	E(*) [mm]	F [mm]
100	210	170	4	18	290	390	150
150	265	225	8	18	315	415	150
200	320	280	8	18	340	440	150
250	375	335	12	18	366	466	150
300	440	395	12	22	398	498	150
350	490	445	16	22	450	550	150
400	540	495	16	22	450	550	150
450	595	550	16	22	478	578	150
500	645	600	20	22	502	602	200
600	755	705	20	26	610	710	200
700	860	810	24	26	610	710	200
800	975	920	24	30	678	768	200
900	1075	1020	24	30	728	818	250
1000	1175	1120	28	30	778	868	250
1200	1405	1340	32	33	1022	1112	250
1400	1630	1560	36	36	1025	1095	300
1600	1830	1760	40	36	1125	1195	300
1800	2045	1970	44	39	1252	1302	300
2000	2265	2180	48	42	1462	1562	300

DN	EN 1092-1 PN 10						
	ØA [mm]	ØB [mm]	n -	ØC [mm]	D(*) [mm]	E(*) [mm]	F [mm]
100	220	180	8	18	300	400	150
150	285	240	8	22	325	425	150
200	340	295	8	22	350	450	150
250	395	350	12	22	376	476	150
300	445	400	12	22	422	533	150
350	505	460	16	22	433	533	150
400	565	515	16	26	462	562	150
450	615	565	20	26	488	588	150
500	670	620	20	26	515	615	200
600	780	725	20	30	570	670	200
700	895	840	24	30	628	728	200
800	1015	950	24	33	805	895	250
900	1115	1050	28	33	748	838	250
1000	1230	1160	28	33	748	838	250
1200	1455	1380	32	39	918	1008	250
1400	1675	1590	36	42	1048	1118	300
1600	1915	1820	40	48	1168	1238	300
1800	2115	2020	44	48	1288	1338	300
2000	2325	2230	48	48	1492	1592	300

DN	DIN 24154 (part 2)						
	ØA [mm]	ØB [mm]	n -	ØC [mm]	D(*) [mm]	E(*) [mm]	F [mm]
100	162	139	4	10	266	366	150
150	222	191	8	12	291	391	150
200	273	241	8	12	316	416	150
250	323	292	8	12	340	440	150
300	383	349	8	12	370	470	150
315	398	366	8	12	380	480	150
355	438	405	8	12	400	500	150
400	484	448	12	12	422	522	150
450	534	497	12	12	448	548	150
500	584	551	12	12	472	572	200
600	705	665	16	14	532	632	200
630	734	698	16	14	547	647	200
710	814	775	16	14	587	687	200
800	904	861	24	14	642	732	200
900	1004	958	24	14	692	782	250
1000	1105	1067	24	14	742	832	250
1120	1245	1200	32	18	812	902	250
1250	1375	1337	32	18	897	967	250
1400	1525	1475	32	18	972	1042	300
1600	1725	1675	40	18	1072	1142	300
1800	1925	1875	40	18	1192	1242	300
2000	2125	2005	40	18	1330	1430	300

Damper valves type AFT-DV of other sizes (face-to-face lengths, drilling patterns, nominal diameters, temperatures, pressures) are available on request

(*) Depending on the temperature of the medium measures can vary - due to applying of thermal isolation of the actuator or dismountable shaft/actuator coupling

Materials*

	Temperature			
	up to 370°C	from 370°C up to 450°C	from 450°C up to 550°C	from 550°C up to 750°C
Body	S235JR or S355JR X5CrNi18-10 (1.4301)	P265GH X5CrNi18-10 (1.4301)	16Mo3 X15CrNiSi20-12 (1.4828)	X15CrNiSi20-12 (1.4828) 253 MA (1.4835)
Disc	S235JR or S355JR X5CrNi18-10 (1.4301)	P265GH X5CrNi18-10 (1.4301)	16Mo3 X15CrNiSi20-12 (1.4828)	X15CrNiSi20-12 (1.4828) 253 MA (1.4835)
Shafts	X20Cr13 (1.4021)	X20Cr13 (1.4021)	X15CrNiSi20-12 (1.4828)	X15CrNiSi20-12 (1.4828)
Sealing	graphite	graphite	graphite	graphite

* - standard executions

Final material execution depends on specific medium, working conditions and customer requirements.

For special high temperature executions ceramic lining inside the body is applied according to customer requirements. In special cases to achieve high corrosion resistance, the blades can be lined with high corrosion resistant and high temperature resistant alloy steel.

Actuators and Accessories

Hand lever

Equipment:
Scale and position locking device

Manual gear box

Equipment:
electromechanical limit switches or proximity or AS-i

Single or double acting pneumatic actuators (quarter turn, linear)

Equipment:
- solenoid valve
- electromechanical limit switches or proximity
- electropneumatic positioner 4-20 mA
- pneumatic accessories AS-i, PROFIBUS, HART

Open/close or regulating electric actuators

Equipment:
- stroke and torque limit switches
- position transmitter 4-20mA
- positioner
- local control unit
- equipment for PROFIBUS, HART systems etc.

Emergency functions (options)

In case of control air failure the valve:
- closes
- opens
- stays in the last position

In case of voltage supply failure the valve:
- closes
- opens
- stays in last position

Special executions

- hand chain drive
- drive system consisting of electric actuators, electromagnetic couplings, hydraulic dampers (quick closing or quick opening valves for emergency modes of operation)
- drive transmission systems – shaft angle extensions for non typical applications