

AFT-DV/LDV T or DB version

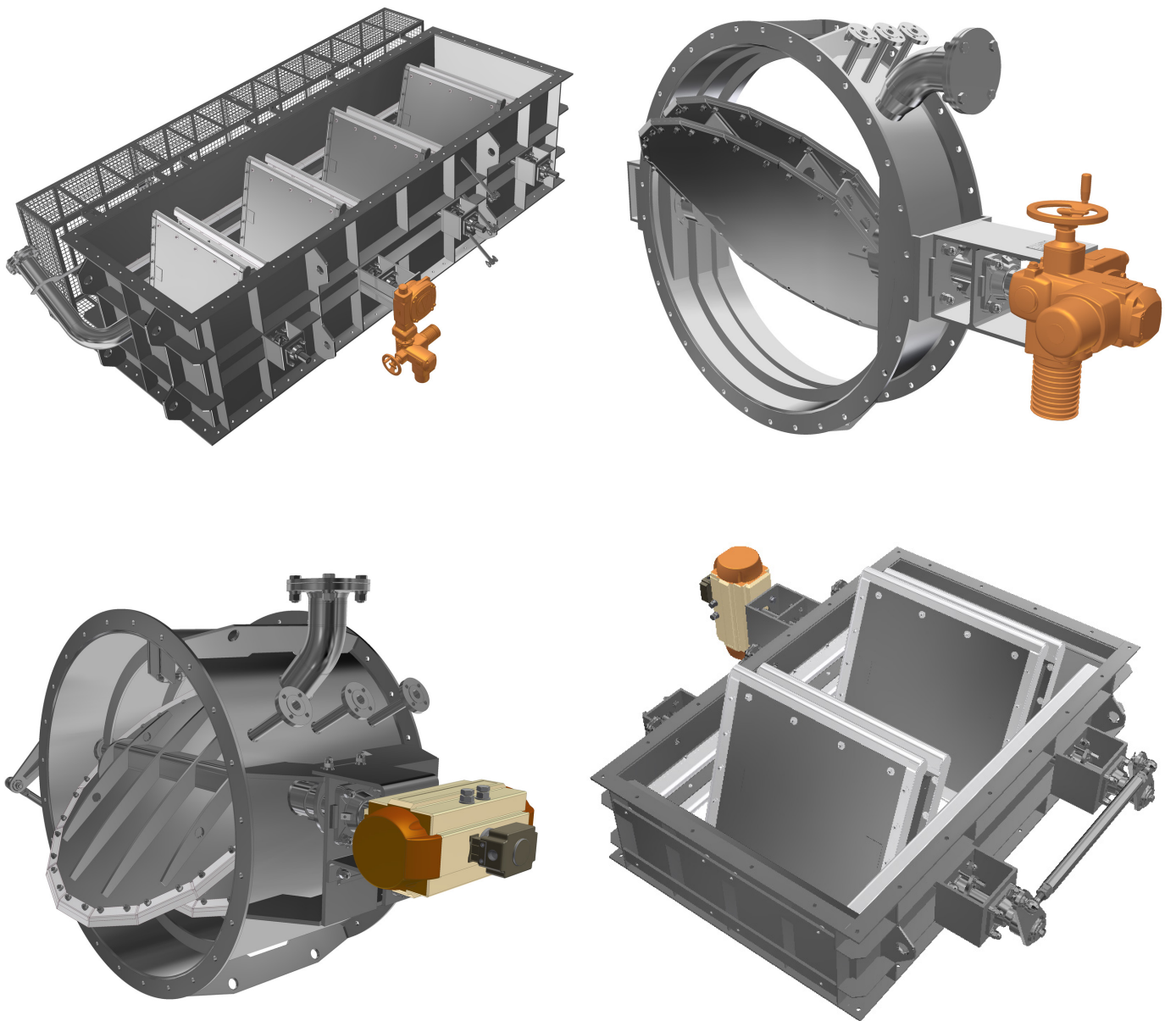

Damper valves with seal air system

Technical description

Damper valves type AFT-DV and AFT-LDV as T (tandem) or DB (double blade) execution are of welded construction and are designed as 100% tight valves to shut-off media such as air, process gas, etc.

Such gas tight shut-off applications are required in flue gas desulphurisation, dust extraction of furnaces, utilisation of SO₂, SO₃, NO_x as well as for air tight sealing of production processes in smelters, chemical and paper industry, glass smelters, non-ferrous metals smelters, etc.

Due to their material selection, precise execution and control technology these dampers have to be important and reliable components of a plant and are subject of technical tests, especially concerning their tightness.

Product properties T/DB

For more technical data see catalog AFT-DV or AFT-LDV

Diameter range AFT-DV

DN200 – DN9600
(larger sizes on request)

Dimension range AFT-LDV

max. 12000x12000mm (larger sizes on request)

Design pressure

< 0,5 bar

Temperature range

-20°C up to +750°C or acc. to customer request
(max. working temperature up to 1100°C)

Gland packing

graphite
(other depending on medium and temperature)

Installation of dampers

face-to-face length, working position
(acc. to customer requirements)

Materials

Depending on medium, temperature, customer requirements

Actuators

Pneumatic quarter turn or linear actuators with accessories acc. to technical and customer requirements

Electric quarter turn actuators with accessories acc. to technical and customer requirements

Special design:

- actuating systems equipped with electric actuators, electromagnetic couplings, hydraulic dampers (quick closing or quick opening valves for emergency modes of operation)
- actuating systems with counterweights or return springs (quick mechanical safety actuators in case of emergency – closing or opening)

Damper valve types

Damper valve T type

P_A – seal air

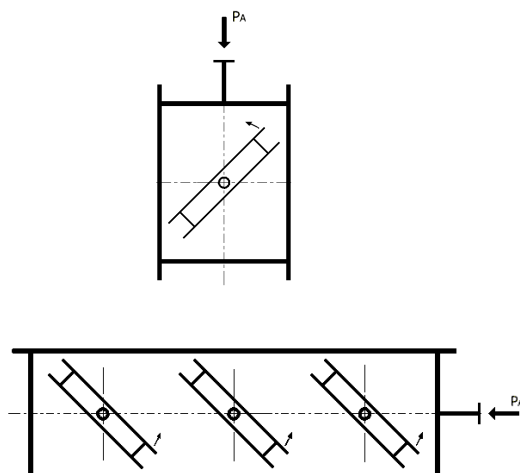

Damper valve DB type

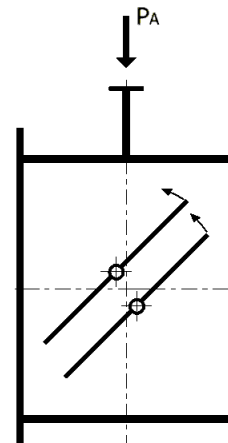

Execution

The construction of **T type** (tandem) dampers consists of two coupled blades on each shaft. These blades are reinforced with a grate construction which ensures their rigidity and low weight at a low pressure drop.

In case of **DB type** dampers (double blade) there are two independent blades, each on its own shaft. The shafts are located eccentrically in the housing. Due to the fact that both damper shafts are coupled by means of levers and rods, both blades turn in the same way.

Depending on the design, the damper blades can be welded with shafts or can be detachable by means of pins (exchangeable blades). The number of blades and their size is defined and selected depending on operating conditions and flue gas ducts dimensions.

Sealing principle

- P_U – medium pressure (at damper inlet)
- P_A – air pressure (seal air pressure)
- P_D – medium pressure (at damper outlet)

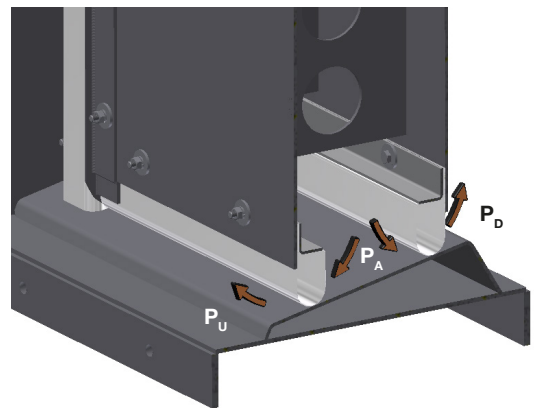
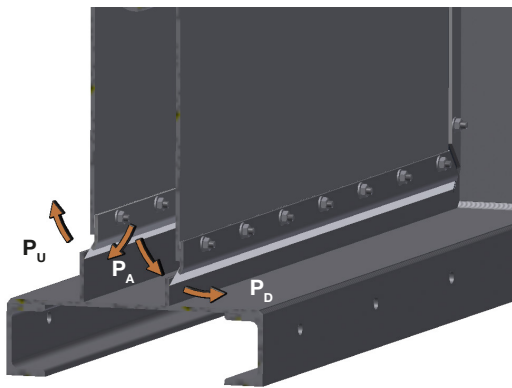

The medium tight shut-off in the duct for such types of dampers is realized by using a seal air system. In such a system seal air is injected between the two blades with relevant pressure, being slightly higher than the pressure of the medium in the duct. Thus a so called “air barrier” is created, giving 100% tightness through the closed damper. It guarantees complete separation of the medium in the duct.

The seal air pressure and air consumption required for 100% tightness of the damper in closed position depends on the operating conditions and is individually calculated for each type of damper. Some leakage of seal air to the duct is allowable and results directly from the sealing principle.

Depending on the application of installation, in which the dampers are mounted, the seal air system can comprise an air preheater. Preheated air protects the dampers from corrosion attack (at defined operating conditions).

The sealing elements mounted on blade edges, designed as bars or closed profiles, are made from high alloyed elastic stainless steel, resistant to corrosion and high temperatures.

Example diagram of flue gas desulphurisation plant (FGD) using AFT-DV and AFT-LDV dampers with seal air inlet system

The diagram shows possible applications of AFT-LDV-T and AFT-DV-T dampers in a FGD plant

- 1, 5 – shut-off damper type AFT-LDV-T
- 3, 4 – fast opening damper type AFT-LDV-T
- 2 – shut-off damper type AFT-DV-T

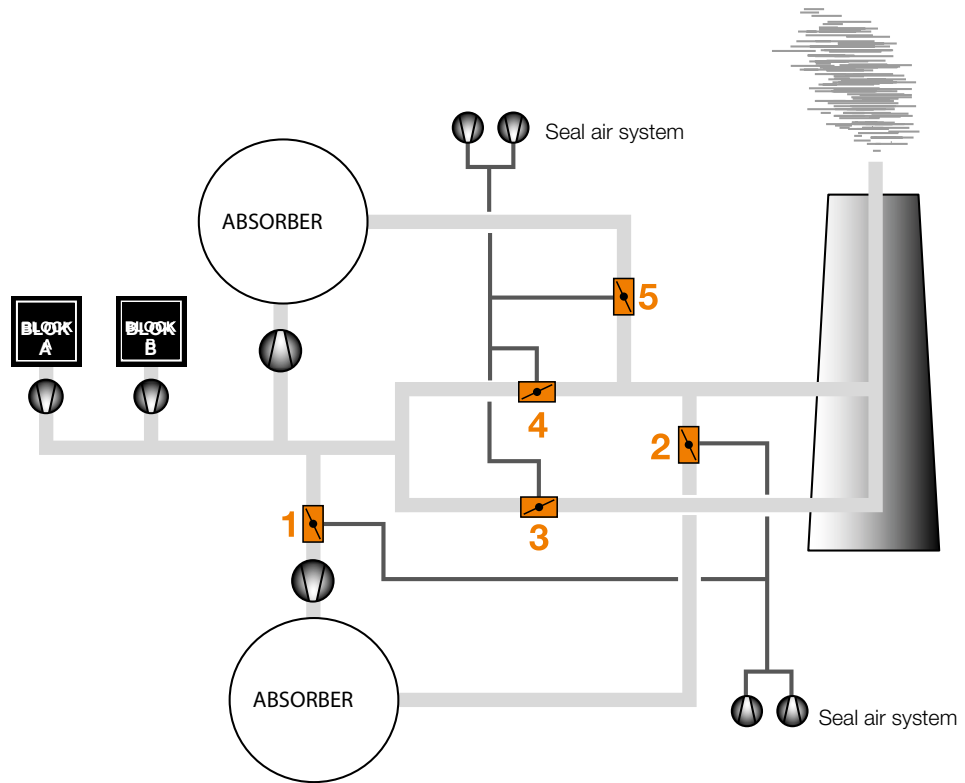

Example seal air diagram for AFT-LDV-T i AFT-DV-T dampers

- A – damper actuator
- B – damper (in closed position)
- C – pressure sensors (for $P_U / P_A / P_D$)
- D – damper blades position sensors
- E – temperature sensors
- F – shut-off valve
- G – air preheater module
- H – regulating valve
- I – fan module
- J – control module

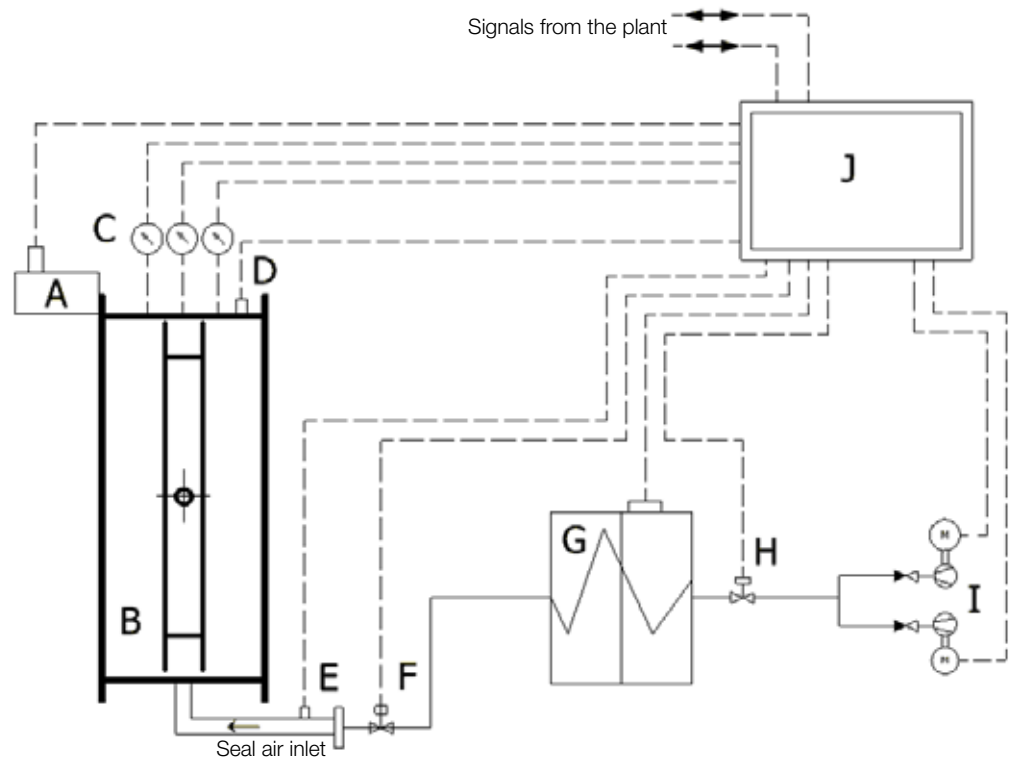

AFT Sp. z o.o.
 ul. Zielna 1
 62-002 Suchy Las · PL
 tel. +48 61 820 51 45
 fax +48 61 820 69 59
 info@aft.pl
 www.aft.pl